

AN-3200

Installation and Configuration Manual

Publication 1088-366
Rev. E
March 2015

AMETEK POWER Instruments
255 N. Union Street
Rochester, New York 14605

Tel: (800) 881-4156
Fax: (585) 238-4945
Web: www.ametekpower.com

Please Read This First!

IMPORTANT NOTES

**THOROUGHLY READ AND UNDERSTAND THE SAFETY SECTION BEFORE
ATTEMPTING TO INSTALL AND ENERGIZE A SYSTEM**

**UNAUTHORIZED MODIFICATIONS OR REPAIRS WILL INVALIDATE THE
AMETEK WARRANTY PLEASE CONTACT THE AMETEK CUSTOMER
SERVICES DEPARTMENT BEFORE TAKING SUCH ACTIONS**

**STANDARD DEFAULT SETTINGS ARE INDICATED IN THIS MANUAL TO
WHICH AN-3200 ANNUNCIATORS WILL BE SET SHOULD NO SPECIFIC
CONFIGURATION OR SET UP DETAILS BE SUPPLIED WITH PURCHASE
ORDERS**

Table of Contents

SCOPE	1
PRODUCT OVERVIEW	1
SAFETY	1
CONSTRUCTION	1
SYSTEM FRONT VIEW	1
SYSTEM REAR VIEW	1
MODULE CELL	2
CELL ASSEMBLY	2
MODULE CELL CONFIGURATIONS	3
ANNUNCIATOR WINDOWS	3
ANNUNCIATOR MODEL CODE DEFINITION	4
SYSTEM CONFIGURATION AND SET-UP	7
HARDWARE CONFIGURATION	8
I/O MODULES	8
FIELD CONTACT TYPE	8
FIELD CONTACT VOLTAGE (FCV)	9
OPTIONAL REPEAT RELAYS	9
I/O MODULE CONFIGURATION	10
I/O ADDRESS	11
DISPLAY MODULE	12
COMMON SERVICE MODULES	13
COMMON SERVICE PUSHBUTTON ASSEMBLIES	14
COMMUNICATION MODULES	14
SERIAL/ETHERNET COMMUNICATION MODULE	15
CARRIER CARD	16
COMMUNICATIONS CARD	16
GROUND FAULT DETECTOR MODULE	17
POWER SUPPLY MODULES	17
FIELD CONTACT VOLTAGE SUPPLY MODULES	18
IRIG-B MODULE	18
INSTALLATION	19
MOUNTING	19
PANEL MOUNTING(OPTION PM, PC)	19
19" RACK MOUNTING (OPTION RK)	21
NEMA ENCLOSURE (OPTION N4, N4PB)	22
SURFACE (WALL) MOUNTING (OPTION S)	23
WEATHER TIGHT NEMA FRONT COVER (OPTION NCB, NCT)	25
EXTERNAL POWER SUPPLY MOUNTING	29
120/230VAC POWER SUPPLY	29
125VDC POWER SUPPLY	29
WIRING	30
INPUT WIRING	30
COMMON FIELD CONTACT VOLTAGE	30
ISOLATED FIELD CONTACT VOLTAGE	31
INPUT / RELAY WIRING FOR FULL SIZE WINDOWS (USING ONE I/O CARD)	32
INPUT/RELAY WIRING FOR HALF SIZE WINDOWS (USING ONE I/O CARD)	33
INPUT/RELAY WIRING FOR HALF SIZE WINDOWS (USING ONE I/O CARD)	34
INPUT WIRING WITH HALF SIZE WINDOWS (USING TWO I/O CARDS)	35
REPEAT RELAY WIRING FOR HALF SIZE WINDOWS (USING TWO I/O CARDS)	36
INPUT/RELAY WIRING FOR QUAD SIZE WINDOWS (USING TWO I/O CARDS)	38
COMMON SERVICE CELL WIRING (WITH INTEGRAL PUSHBUTTONS)	39
COMMON SERVICE WIRING (WITH I/O MODULES)	40
CONNECTING POWER	41

120/230 VAC & 125VDC INPUT POWER	41
FIELD CONTACT VOLTAGE	41
POWER REQUIREMENTS	42
EXTERNAL AC SUPPLY:	42
INTEGRAL AC SUPPLY:	42
INTEGRAL POWER SUPPLY	43
125VDC OR 120/230 VAC INTEGRAL POWER SUPPLY	44
125VDC OR 120/230VAC INTEGRAL FIELD CONTACT VOLTAGE (FCV) SUPPLY	45
120/230 VAC AND 125 VDC INTEGRAL POWER SUPPLY WIRING	46
24VDC INTEGRAL POWER / FCV SUPPLY	47
48VDC INTEGRAL POWER SUPPLY	48
24 AND 48 VDC INTEGRAL POWER SUPPLY WIRING	49
EXTERNAL POWER SUPPLY	50
125 VDC EXTERNAL POWER SUPPLY WIRING	50
120/230 VAC EXTERNAL POWER SUPPLY WIRING	52
SOFTWARE CONFIGURATION	53
APPLICATION	53
SOFTWARE INSTALLATION	53
SOFTWARE CONFIGURATION INSTRUCTIONS	54
REVIEWING OR EDITING THE FACTORY CONFIGURATION	54
CREATING A NEW CONFIGURATION	55
SOFTWARE CONFIGURATION MENUS	56
MAIN MENU OVERVIEW	56
FILE MENU	56
OPTIONS MENU	56
VIEW MENU	56
CONNECTIONS MENU	56
HELP MENU	56
FILE	57
OPTIONS	59
VIEW CONFIGURATION (TEXT)	60
CONFIGURATION WIZARD	65
SYSTEM	66
INPUT CONFIGURATION	69
ALARM NUMBERING	69
SWITCH INPUTS	78
EXTERNAL SWITCH FUNCTION SETTINGS	78
TEST CONFIGURATION	79
OTHER SYSTEM CONFIGURATIONS	79
ASCII	80
SETTINGS FOR SERIAL PORT (OPTION SPT)	80
MODBUS	82
SETTINGS FOR ETHERNET (OPTION ETH)	82
SETTINGS FOR SERIAL PORT (OPTION SPT)	83
COMMON MODBUS SETTINGS	84
DNP3.0	86
SETTINGS FOR ETHERNET (OPTION ETH)	86
SETTINGS FOR SERIAL PORT (OPTION SPT)	87
COMMON DNP CONFIGURATION SETTINGS	88
SYSTEM SPECIFICATIONS	91
INPUTS	91
DISPLAY	91
REPEAT RELAY OUTPUTS	92
ALARM SEQUENCE	93
CONTROLS	94
SYSTEM RELAYS	94
AUDIBLE DEVICES	94
COMMUNICATIONS	95
TIME STAMPED ALARMS	95
INDICATORS	96
POWER REQUIREMENTS	96

MECHANICAL.....	97
CONNECTIONS / TERMINATIONS.....	97
ENVIRONMENT.....	97
ELECTRICAL.....	98
CERTIFICATIONS.....	98
SERVICING.....	99
MODULE REMOVAL.....	99
ESD.....	100
APPENDIX A.....	101
OPERATIONAL SEQUENCES.....	101
LEGEND.....	104
APPENDIX B.....	105
MODBUS DATA FORMATS.....	105
POINT MODE.....	106
AN3135 MODE.....	107
EVENT DATA.....	108
MODBUS ADDRESSES.....	109
DEFAULT VALUES.....	109
APPENDIX C.....	111
DNP DATA FORMATS.....	111
DEVICE PROFILE DOCUMENT.....	111
IMPLEMENTATION TABLE.....	112
PUSHBUTTON CONTROLS.....	113
AN-3200 DATA MAP.....	114
BINARY INPUTS.....	114
BINARY INPUT CHANGE WITH TIME (SER OPTION).....	114
APPENDIX D.....	116
ASCII OUTPUT FORMAT.....	116
APPENDIX E.....	117
WEB OPTION.....	117
AN-3200 HOME PAGE.....	119
WEB PB CONTROL.....	119
HOME PAGE EDITABLE FIELDS.....	120
STATION ID.....	120
DEVICE ID.....	120
WHO TO CONTACT.....	120
CUSTOMER.....	120
WEB BROWSER NAVIGATION.....	121
ACTIVE ALARMS PAGE.....	122
EVENT LOG PAGE.....	123
EVENT DESCRIPTOR.....	124
DOWNLOAD FILE (.CSV).....	125
ERASE THE LOG (<i>ONLY FOR ADMINISTRATORS</i>).....	125
PRINT EVENTS.....	125
MAXIMUM EVENTS TO RETRIEVE.....	125
EVENT SORTING AND FILTERING.....	126
EVENT SORTING.....	126
FILTER EVENTS BY:.....	126
DATE & TIME FILTER.....	126
DESCRIPTOR FILTER:.....	127
POINT NUMBER(S) FILTER:.....	127
ACCESS CONTROL CONFIGURATION.....	128
USER ACCOUNT CAN:.....	128
ADMIN ACCOUNT CAN:.....	128
TRUSTED IPS/HOSTNAMES.....	130

PORTS	130
HTTPS	130
NTP OPTION	131
EMAIL OPTION	132
ALARM INPUTS	133
SAVE AND RESTORE CONFIGURATION	134
FIRMWARE CONFIGURATION	135
COLOR SELECTION.....	137
LOGON AS USER	138
DOCUMENTATION	138
APPENDIX F	140
WINDOW ASSEMBLY DETAILS	140
WINDOW LEGENDS	140
WINDOW COLORS.....	140
WINDOW ASSEMBLY	141
APPENDIX G BROWSER COMPATIBILITY	143
APPENDIX H NOTES ON SAVING THE EVENT FILE AS .CSV.....	145
APPENDIX I ALTERNATE METHOD FOR ETHERNET CONFIG	147
APPENDIX J	148
TELEPHONE / FAX NUMBER LIST	148
PROCEDURES FOR FACTORY REPAIR AND RETURN.....	149
WARRANTY.....	149

SCOPE

This manual describes the installation and configuration of the AN-3200 annunciator system. This includes operation of its associated configuration software.

Glossary of Terms

Cell:	Refers to a single module housing that can accommodate several boards. An Annunciator that is 3 rows high by 4 columns wide consists of 12 Cells.
Module:	Refers to an individual electronic board. There are a variety of boards used in the Annunciator System for inputs, outputs, communications, etc.
N.O.	Normally Open. Contact state is open when normal, closes upon alarm.
N.C.	Normally Closed. Contact state is closed when normal, opens upon alarm.
Energized:	Typically refers to the relay coil state when normal. The coil de-energizes (voltage removed) when in alarm or while activated.
De-Energized:	Typically refers to the relay coil state when normal. The coil energizes (voltage applied) when in alarm or while activated.
Form A	Type of relay contact, SPST (single pole, single throw). Open in the normal state, closes upon alarm or while activated.
Form B	Type of relay contact, SPST (single pole, single throw). Closed in the normal state, opens upon alarm or while activated.
Form C	Type of relay contact, SPDT (single pole, double throw). Open and closed contact with common pole. Both change state when in alarm or while activated.
FCV:	Field Contact Voltage. Field contact or wetting voltage for alarm inputs.
CSM:	Common Service Module. The CSM provides common alarm controls and output relays. Typically located in the bottom right cell.
I/O:	Input/Output. This refers to a board that accepts the customer Field Contact Inputs, provides outputs to the LED Display and can provide optional repeat relays.

PRODUCT OVERVIEW

SAFETY

The following safety symbols are used on the AN-3200:



Caution, risk of danger. Refer to the Instruction Manual.



Caution, risk of electric shock.



Protective Earth Conductor Terminal

The AN-3200 is CE certified for operation under the following conditions:

Indoor Use (unless mounted in NEMA-4 enclosure option)

Altitude up to 2000 m

Operating Temperature Range: -20 TO 50 °C (-4 to 122°F)

Relative Humidity: 20-95% RH

Mains supply voltage fluctuations: +/- 10% of nominal

Transient Over voltages: 2500 V (Installation or Measurement Category II)

Pollution Degree 2

In product configurations with 125VDC or 120VAC Field Contact Voltage (options: D, DC, D/ISO, Y/ISO), the system must be equipped with the lockable front door (options NCB, NCT) or NEMA Enclosure (options N4, N4PB) Annunciator Model Code Definition on page 4.

For FM option (pending) (refer to option codes), the required door may be supplied by Ametek, a panel shop or the customer. The door must meet the FM standard for requiring a tool to open or remove the door to allow access to the front of the Annunciator.

Also, 120/230VAC & 125 VDC Input Power (options A, B, C) must use external power supplies, unless the front door or NEMA enclosure is used. All other product configurations can be installed in any enclosure as specified in the model number table, item 1.

Installation and start-up must be carried out by trained and qualified personnel.

If the unit is not installed and operated as specified, the protection provided by the unit may be impaired.

Before start-up, it is important to ensure that:

1. The unit can be switched off by a switch, or a circuit breaker, clearly marked as the disconnecting device for the unit. The minimum rating of the disconnecting device is:
 - 5 Amps for 120 Vac or 230 Vac power
 - 10 Amps for 24 or 48 Vdc power
2. The disconnecting device is located in close proximity to the unit and must be marked as the disconnecting device for the unit.
3. The protective earth terminal is properly connected to protective earth.
4. The line has been connected correctly and protection is provided against electric shock.
5. Proper ventilation is provided by at least 6 inches (15.25 cm) above and below the unit

CONSTRUCTION

The AN-3200 is a modular design constructed from a matrix of cells up to 13 high by 13 wide. The cells can be configured for 1, 2, 3 or 4 points per cell. Each cell provides front access to the electronics and all wiring connections are made to the rear of the unit. Each cell can accept several modules in various combinations, consisting of I/O Cards, Common Service Modules, Power Supplies and Option Modules. The Common Service Module (CSM) is typically located at the lower right cell of the unit and the other cells are used for I/O.

System Front View



System Rear View

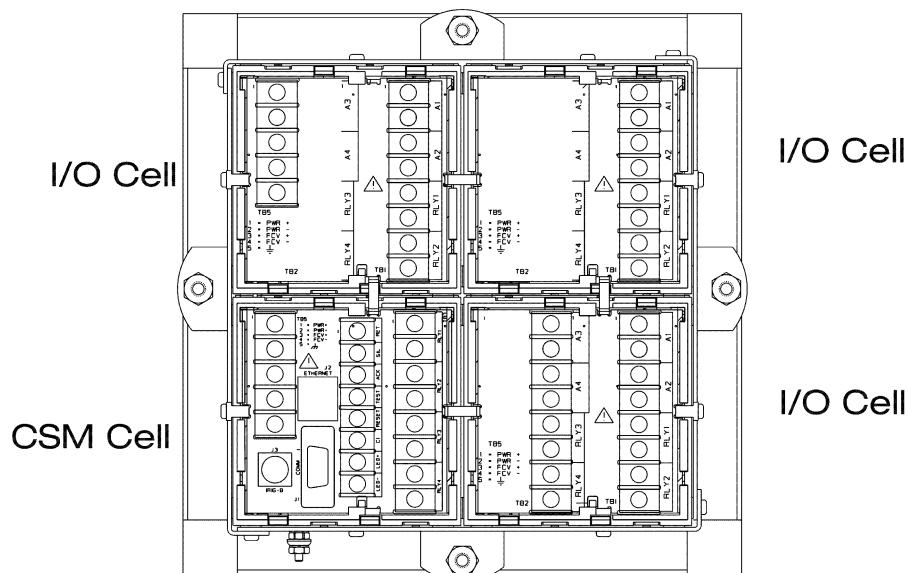

Module Cell

The Annunciator is a modular construction made from individual cells, allowing any size high or wide up to 13. All cards are removable from the front of the unit, after removing the window or pushbutton assembly.

Cell Assembly

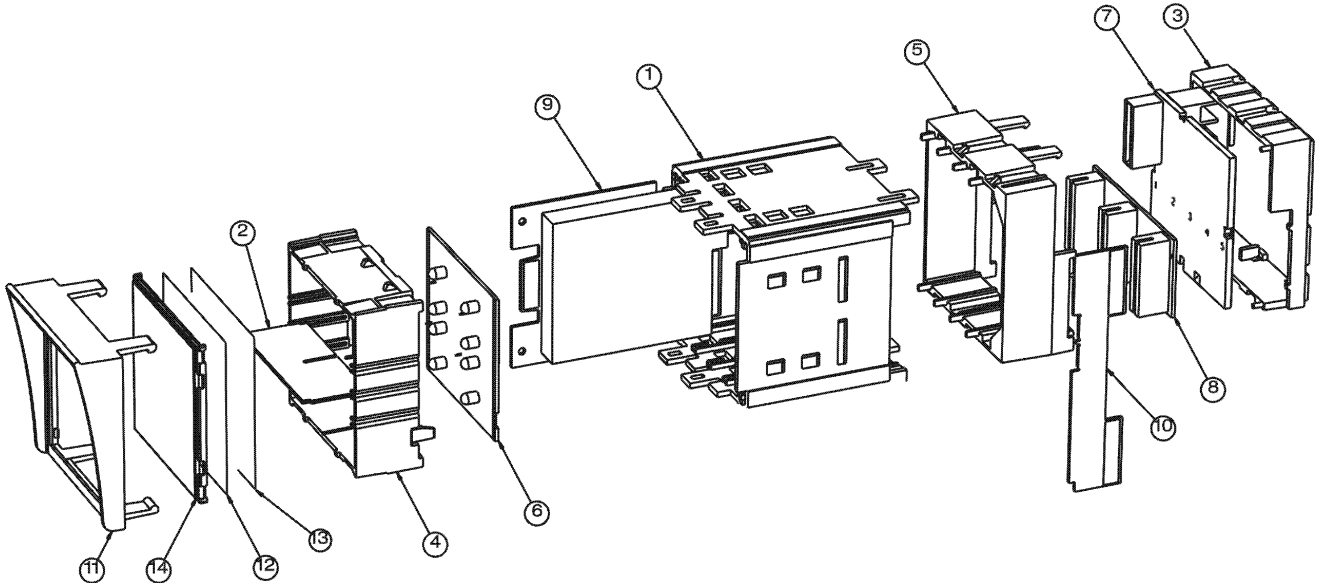

Item #	Part Description	Item #	Part Description	Item #	Part Description
1	Module Cell	6	Display Board	11	Window Housing
2	Window Divider	7	Back-plane Assembly	12	Window Legend
3	Back-plane Housing	8	Interconnect Board	13	Color Diffuser
4	Display Housing	9	Module (see list)	14	Window
5	Rear Cell Housing	10	Row Interconnect Board		

Available Modules:

- **I/O** Input / Output Module, with optional Repeat Relays
- **LED** LED Display Module
- **CSM** Common Service Module & Sequential Events Recording CSM
- **COMM** Communication Module: Serial & Ethernet
- **PS** Power Supply: Integral AC/DC Universal, Integral DC/DC
- **FCV Supply** Field Contact Voltage Supply: Integral AC/DC Universal
- **IRIG-B** Time Synchronization Input Module used for Sequential Events Recording
- **Ground Fault** Ground Fault Detector Module

Module Cell Configurations

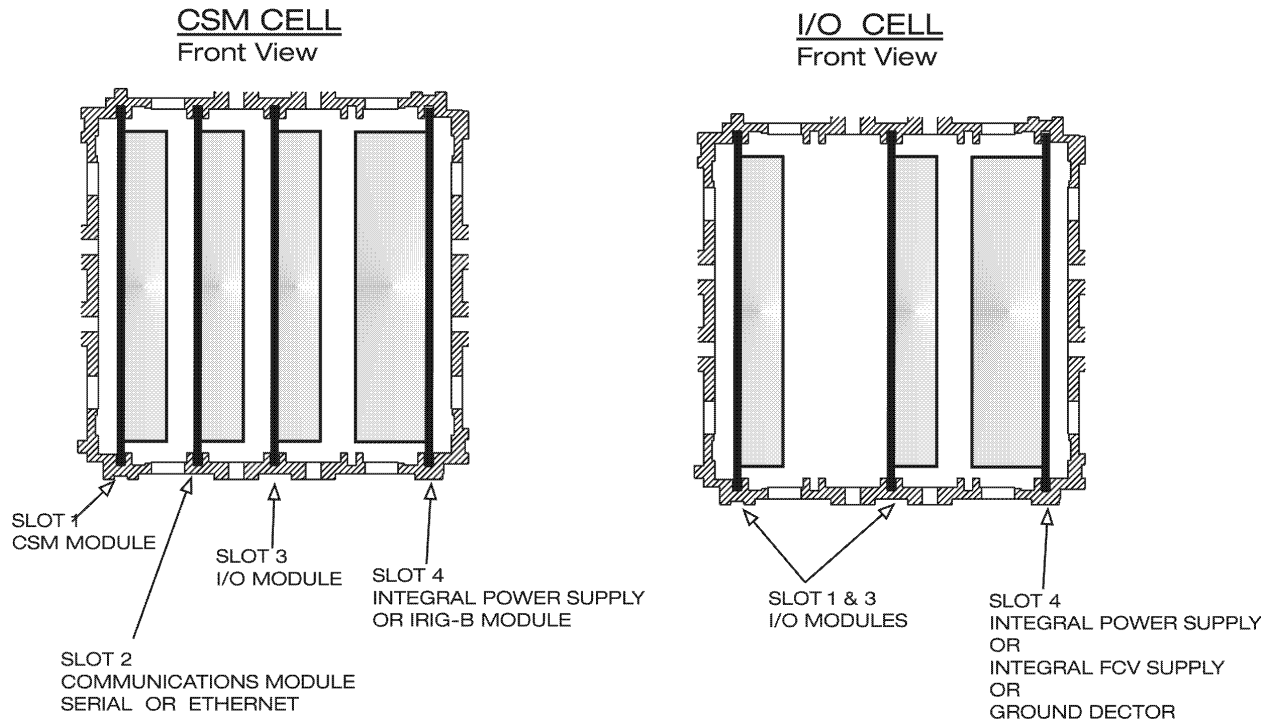

Note: Slot 5 of the I/O cell is also used for a row to row interconnect board (item #10 on cell assembly figure), which is installed for every row of the Annunciator. When installed; no other card or power supply can be inserted in that slot. All other unused slot 5 positions in that row can be used for power supplies or a ground detector. (This will be factory configured)

Annunciator Windows

The Annunciator windows come in four sizes as shown below. Legends can be laser printed on transparency film and inserted into the window frame. Colored filters are inserted behind the legends. Reference the appendix for additional details.

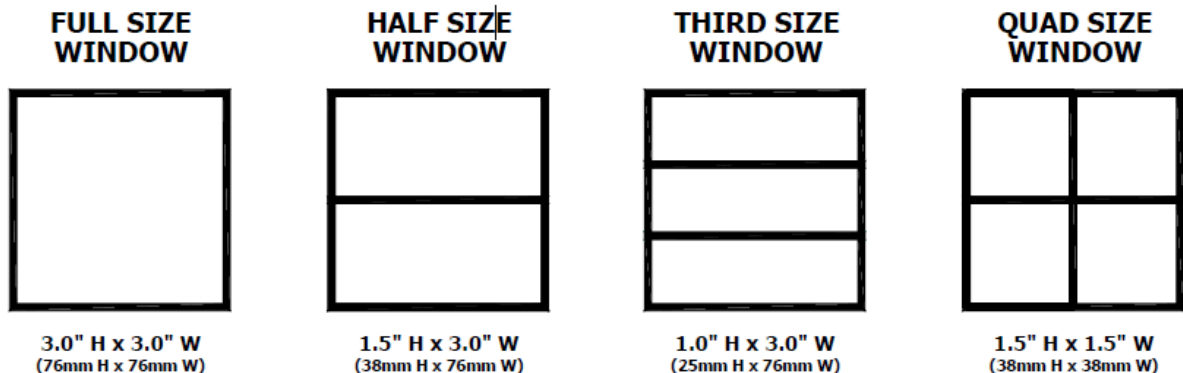

ANNUNCIATOR MODEL CODE DEFINITION

AN-3200 Model Number

AN-3200-	-	-	-	-	-	-
Item 1 Mounting Options	Item 2 # of Cells High	Item 3 # of Cells Wide	Item 4 Common Service	Item 5 Window Size	Item 6 Active Points	Item 7 Window Color
-	-	-	-	-	-	-
Item 8 Operational Sequence	Item 9 Repeat Relay	Item 10 Power Input	Item 11 Field Contact Voltage	Item 12 Window Legends	Item 13 Comm. Options	Item 14 Options

Example: AN-3200-PM-3H-6W-INTB-2-34-W-A-RR-B-X-TP-MB-TS-IB-RLY

Item 1 Mounting Options

PM	Semi-Flush Panel Mounting
PC	Semi-Flush Panel Mounting w/rear cover
RK	19" Rack Mounting (5 wide systems only)
S	Surface (Wall) Mounting (1H to 5H x 2W to 5W)
NCB	Weather-tight NEMA Front Cover w/ ¼-20 Bolts
NCT	Weather-tight NEMA Front Cover w/T Handle
N4	NEMA-4 Enclosure (1H to 6H x 3W to 8W)
N4P	NEMA-4 Enclosure w/PB (1H to 6H x 3W to 8W)

Item 2,3 Annunciator Size

# of Cells	# of Cells Wide
	H (2-13)
	i
	g
	h
(1-13)	

Item 4 Common Service Cell (lower right cell)

INTB	Integral Pushbuttons (ACK, SIL, TEST, RESET)
NPB	Pushbuttons replaced w/ a Half or Full Size Window
LPP	Low Profile Integral Pushbutton attached to bezel. CSM Cell has Half or Full Size Window

Note: For either selection above, external pushbuttons can be connected to the Annunciator terminal blocks.

Item 5 Window Size

4	Quad Size, 4 inputs per cell, ea 1.5"H x 1.5"W
3	Third Size, 3 inputs per cell, ea 1.0"H x 3.0"W
2E	Half Size, 2 inputs per cell, ea 1.5"H x 3.0"W
2S	Half Size, 2 inputs per cell, ea 1.5"H x 3.0"W
2	Half Size, 2 inputs per cell, ea 1.5"H x 3.0"W

1E Full Size, 1 input per cell, ea 3.0"Hx3.0"W

IMW Intermixed window size

Note:

Option 1E indicates that the cell is expandable up to 2 inputs.

Option 2E indicates that the cell is expandable up to 4 inputs. Option 2S indicates one input module per single input provided.

Do not include the CSM Cell in your quantity.

Item 6 Active Points

Total # of active points

Item 7 Window Color

W	White Window Filter
R	Red Window Filter
A	Amber Window Filter
G	Green Window Filter
Y	Yellow Window Filter
B	Blue Window Filter
IMC	Intermix color, matrix must be included

Item 8 Operational Sequence

	A; A4; A4-5-6; M; R; R-12 ; F1A; F2A; F3A; F2M-1; FFAM2; F3C ; R12C ; RC
IMO	Intermixed Sequences (up to 4 available)

Item 9 Repeat Relay Option

RR	Auxiliary Repeat Relay Provided for every Input. (Can be field configured to follow: alarm input status, alarm sequence operation or Lamp Flash. Relays can be set for normally energized or de-energized operation and are jumper selectable for a Form A or Form B contact arrangement).
FRC	Auxiliary Repeat Relay Provided for every Input with Form C (SPDT) Contacts. (Can only be used with Window Size 1E or 2S).
2RR	Two Repeat Relays for every input.

(Selectable for a Form A or Form B contact arrangement. Can only be used with Window Size 1E or 2S.)

NR No Repeat Relays required
(Note: Can only choose one selection from above).

Item 10 Power Input

F	24 VDC
E	48 VDC
C	125 VDC
B	120 VAC, 60 HZ
A	230 VAC, 50 HZ

Item 11 Field Contact Voltage (FCV)

Field Contact Voltage internally supplied by AMETEK, with common system-wide FCV return.

*For System Input Power Voltages of 120/230VAC or 125VDC.

D	125 VDC FCV
X	24 VDC FCV

Field Contact Voltage externally supplied by Customer, internally bussed to all input modules.

DC	125 VDC FCV supplied by Customer
TC	48 VDC FCV supplied by Customer
XC	24 VDC FCV supplied by Customer
JC	12 VDC FCV supplied by Customer

Field Contact Voltage externally supplied by Customer.

Every input is isolated and requires a separate FCV connection.

D/IS	125 VDC FCV supplied by Customer
T/IS	48 VDC FCV supplied by Customer
X/IS	24 VDC FCV supplied by Customer
J/IS	12 VDC FCV supplied by Customer
Y/IS	120 VAC FCV supplied by Customer
NR	No Field Contact Voltage (Serial Input Only)

Item 12 Window Legends

TP	Legends printed on Transparency Film (field changeable)
E	Legends Engraved on Windows

Note: Window engraving or printed legends can be provided at the factory at no charge if provided 1 week before shipment.

Item 13 Communications

SPT	Serial Port RS-232/485 (field selectable) Used with Communication Protocol Option: SIM, MB, DNP or SD
ETH	Ethernet Port (RJ45) Used with Communication Protocol Option: SIM, MB, DNP and WEB
NR	No Communications Required

Can select both SPT and ETH for dual communications

Item 14 Communication Protocols

SIM	Modbus Communications, Receive Alarms Only. No Field Contact Inputs. Can be used with Serial port (Option SPT), and Ethernet (Option ETH)
MB	Modbus Bidirectional Communications. Transmit or Receive alarms. Can be a mixture of Modbus generated alarms or field contact inputs. Modbus RTU used for Serial Port (Option SPT), TCP-IP used for Ethernet, (Option ETH)
DNP	DNP 3.0 Communications, Transmit Alarms. Can be used with Serial port (Option SPT), and Ethernet (Option ETH)
SD	Serial ASCII Data Output of Time Stamped Alarms Used with the Time Stamping option SER or SERFR, and the Serial port (Option SPT)
WEB	WEB Browser Display of Alarms. Requires Ethernet Option
Email	Email Notification of Alarms. Requires WEB Option

Item 15 Options

FR	1 msec Input Response (50 msec Standard) (This will capture alarms that last 1 msec or longer. If Time Stamping is required, select option SER instead)
SER	Time Stamping of alarms (4 ms resolution) (Each alarm is accompanied with a time stamp, containing point #, alarm state, time & date. The Time Stamp output can be selected as Serial ASCII Data to a printer or terminal [must select option SD], Modbus [must select option MB] or DNP [must select option DNP].)
SERFR	Time Stamping of alarms (1 ms resolution) (Each alarm is accompanied with a time stamp, containing point #, alarm state, time & date. The Time Stamp output can be selected as Serial ASCII Data to a printer or terminal [must select option SD], Modbus [must select option MB] or DNP [must select option DNP]. Option limited to 25 Cells)
IB	IRIG-B Time Sync Input (used with SER Option) (Standard BNC Input)
NTP	NTP Time Sync Input (used with SER Option) (Requires ETH Ethernet Option)

Item 15 Options (continued)

SP	Serial Printer used for Time Stamped Alarms (Used with SER option [time stamped alarms] and SD option [serial data output]. Modbus, DNP and Ethernet are not available when selecting this.)
GF	Ground Fault Detector (internally mounted) For 24, 48, 125VDC Field Contact Voltage (options X, D, XC, DC, TC)
RLY	Additional Two CSM Common Relays (Base system includes 2 CSM Common Relays configurable for Critical or Non-Critical Horn, Ringback Horn. The additional 2 CSM Common Relays can be configured for additional horns or Critical/Non-Critical Reflash or Fault, Power Fail, System Watchdog, or Ground Fault Detect)
SW	External Inhibit Switch Input (Software configurable for inhibit of LED Lamps, Horn, Repeat Relay Outputs or CSM Common Relay Outputs)
HN	Internal Horn
AS	Automatic Horn Silence (Can be used to silence any horn with software configurable delay up to 60 seconds, in 0.25 second increments. Independent setting for internal or external horns)
FS	Flash Synchronization. Synchronizes the flash rate to remote displays. Needs to be specified for each Annunciator that will be synchronized together. (Requires wiring between Annunciator Systems.)
CE	CE Certification CE Certification available for all configurations except for FCV options D, DC, D/ISO, Y/ISO. In these cases, a NEMA Enclosure (option N4, N4PB) or Front Cover (option NCB, NCT) is required. 120/230VAC & 125VDC Input Power provided via External Supplies unless the NEMA Enclosure or Front Cover is used.
STM	Moisture/ Fungus Proof Coating

SYSTEM CONFIGURATION AND SET-UP

The AN-3200 Annunciator is already factory configured per the model number. Most of the configuration of the system is made using software, however some settings such as relay contact arrangement (Form A or Form B) needs to be configured by the user. The default configurations are specified below:

Item		Default Setting	Configuration Method
Inputs	N.O. (normally open), N.C. (normally closed) Field Contact Inputs	N.O.	Software or Hardware *
	Field Contact Voltage (12, 24, 48, 125VDC, 120VAC) OR (24-125VDC)	Factory Configured Per Model Number	Hardware
	Common FCV (field contact voltage) or Isolated FCV		Hardware
	Input Module Address Setting		Hardware
	Operational Sequence (A, M, etc)		Software
	Sequence Grouping	1 group	Software
	Input Response	50 msec	Software
	Critical/Non-Critical Assignment	Non-Critical	Software
Optional Repeat Relays	Form A (normally open), Form B Contacts (normally closed)	Form A	Hardware
	Form C Contacts (SPDT)	Factory Configured Per Model Number	Hardware
	Energized or De-Energized Relays	De-Energized	Software
	Repeat Relay Operation	Follows Input	Software
CSM Functions	Auxiliary Contact Output Type (Form A, Form B)	Form A	Hardware
	Auxiliary Contact Output Mode (Energized or De-Energized)	De-Energized	Software
	Auxiliary Contact Output Operation (Horn, Reflash, Fault, Watchdog, Power Monitor, Ground Fault)	Critical Horn & Non-Critical Horn	Software
	Other system-wide functions	None Selected	Software
Serial Communication Module	RS-232 , RS-485	RS-232	Software
	RS-485 Termination Jumper	Out	Software
	Flash Synchronization (master/slave)	Master	Hardware

*** NO/NC Field Inputs can be configured via the software or hardware, but not both. Choose one method only.**

HARDWARE CONFIGURATION

I/O Modules

Each Input/Output (I/O) module can accept up to two field contact inputs, with field contact voltage (FCV) provided either internally by the Annunciator or externally by the customer. Each input includes optical coupler isolation and can be selected for Normally Open (N/O) or Normally Closed (N/C) Field Contact Inputs through the software configuration or module jumpers. The I/O module provides outputs to the Display Module. Optional relays can be added to the I/O module for repeating the alarm status. Up to two I/O cards can be inserted into Card Slots 1 & 3 of a single cell for a maximum of 4 points per cell. The Cell with the Common Service Module can also support one I/O Module (in slot 3), in place of the Integral Pushbuttons.

Refer to the following table and to the part number affixed to the module to determine the type of module. Note that all modules in a systems shipped from the factory will contain the same type of configuration.

Table 1 Module Types

Description	Part Number
3/4 PT I/O W/RELAY	1087-060
1/2 PT I/O W/RELAY	1087-241
1/2 PT I/O NO RELAY	1087-242
3/4 PT I/O NO RELAY	1087-243
1/2PT SER INPUT ONLY	1087-244
1/2PT SER INPUT ONLY	1087-245

Field Contact Type

The I/O module supports both N/O & N/C inputs through the *software configuration*, as detailed in the next section. N/O refers to Normally Open Field Contacts (open in Normal State, Closed in Alarm State) and N/C refers to Normally Closed Field Contacts (closed in Normal State, open in Alarm State) As an alternative, the N/O and N/C settings may be selected via jumper P5 & P6 on the I/O Module.

NOTE: The NO/NC setting must only be configured via one method (hardware or software). It is recommended to use the software method to avoid any confusion.

Field Contact Voltage (FCV)

Refer to Table-1 Module Types above to determine the type of FCV configuration installed.

I/O modules support Field Contact Voltages with a range of 24 through 125Vdc with no need for configuration jumpers. The Field Contact Voltage can be selected as Common throughout the whole system or Isolated from input to input. This is selected via jumpers J1 & J2.

NOTE: The Annunciator is already factory configured per the selections in the model number.

Optional Repeat Relays

The I/O Module Option RR includes Repeat Relays that can be configured as detailed below.

Repeat Relay Configuration Table

Relay Operation Mode	Relay Contact Status (shown in Normal State)	Relay Coil Status (shown in Normal State)
Repeat Relay Output Follows Input Contact State	OPEN (Form B)	ENERGIZED
	OPEN (Form A)	DE-ENERGIZED
	CLOSED (Form A)	ENERGIZED
	CLOSED (Form B)	DE-ENERGIZED
Repeat Relay Output Latches on Alarm until Acknowledged or Reset	OPEN (Form B)	ENERGIZED
	OPEN (Form A)	DE-ENERGIZED
	CLOSED (Form A)	ENERGIZED
	CLOSED (Form B)	DE-ENERGIZED

NOTE: Option FRC uses a Form C output, which is a SPDT (Single Pole Double Throw) contact. Option 2RR indicates two Repeat Relays for a single alarm input. (used with 1E & 2S Window Sizes) Jumpers P2,3,4 are used to select Form A, B and C modes. The options for the Relay Operation Mode and Relay Coil Status (normally energized or de-energized relays) are selected using the software configuration tool. (Reference the instruction manual section for Software Configuration.

I/O Module Configuration

(1087-xxx modules with auto range FCV)

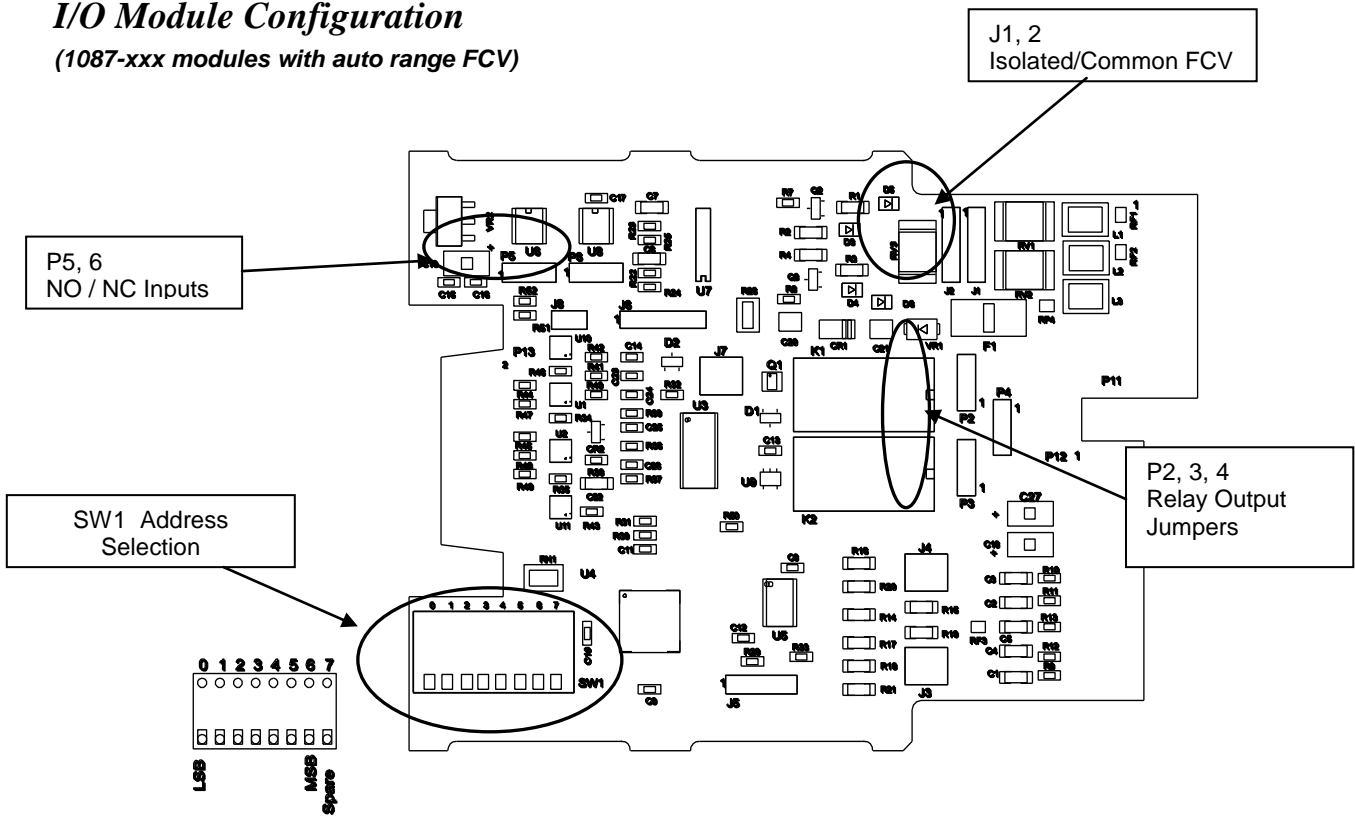

SW1 ADDRESS SELECTION

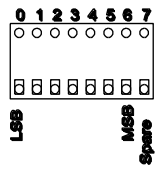

J1,J2: INPUT ISOLATION SELECTION

ISOLATED INPUTS

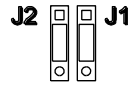

COMMON INPUTS WITH FCV

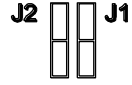

P5,P6: INPUT NORMALLY OPEN (NO)/NORMALLY CLOSED (NC)

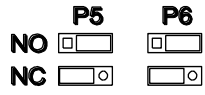

P2,P3,P4: RELAY OUTPUT SELECTION

	FORM A (N.O.)	FORM B (N.C.)	FORM C (SPDT)
RELAY #1:	P2	P2	P2 P4
RELAY #2:	P3 P4	P3 P4	N/A

I/O Address

Each I/O Module requires an address in order for communications to the CSM module. The Address settings are required for configuring any per point parameters and for mapping of serial communications.

There are two versions of input modules using different methods of setting the address. Refer to Refer to Table-1 Module Types to determine which module is in your system.

The I/O address uses a rocker switch (SW1) to indicate a binary address, starting at 0 and incrementing by one for every module in the system, from left to right, top to bottom. In cases where there is only one module per cell (Window code 1E) the binary address will increment by two. Starting at 0 in the first cell, 2 in the second cell, 4 in the third cell etc. Zero is set when all switches are set of off.

NOTE: Care should be taken when removing and replacing I/O modules to insure that they are replaced into the cell from which they are removed. Failure to do so will result in out-of–sequence address.

Alarm numbering...

1	2	5	6		
3	4	7	8		

Display Module

The Display Module provides the LED indication for up to 4 window sizes (Full Size, Half, Third and Quad). Each display module plugs into one or two I/O cards, depending on the window size and input quantities. There are several variations of display modules as noted by the window size in the model number:

Version	Window Size, Configuration
1	1E, 2
2	2S, 2E, 4
3	3
4	1E, 2 (in CSM Cell)

There is no setup required for these modules. (Factory configured)

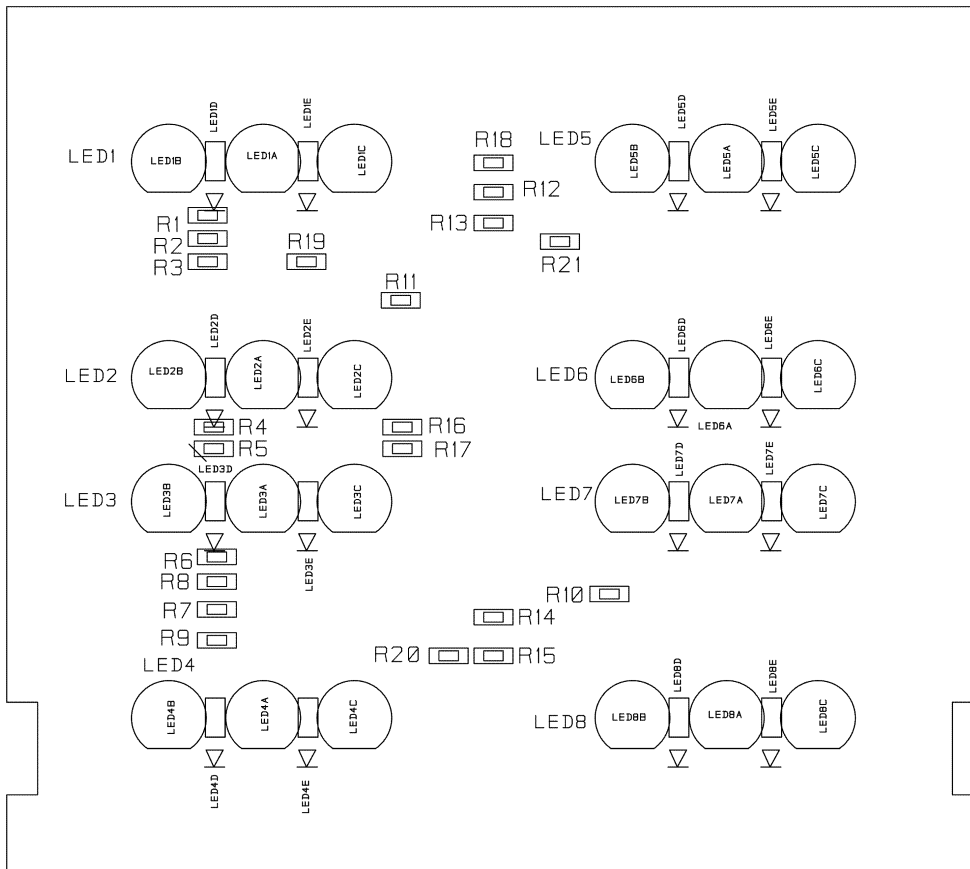

4 Point and all options shown for reference
Not all configurations have all of the displayed components.

Common Service Modules

The Common Service Module (CSM) is typically located in the lower right cell of the Annunciator System in card slot 1. It is used to provide common alarm outputs, perform flashing per selectable ISA Sequences and coordinate the pushbutton controls. One version CSM includes the Time Stamping of Alarms or Sequential Events Recorder (SER). The CSM has four common alarm outputs (2 standard and 2 optional) with relay operation configured via Software. All Annunciator software configuration is performed through the CSM serial port, accessible from the front of unit. The CSM module can be configured via jumpers for Form A or B Relay Contacts.

Relay output selection (LK1-4)

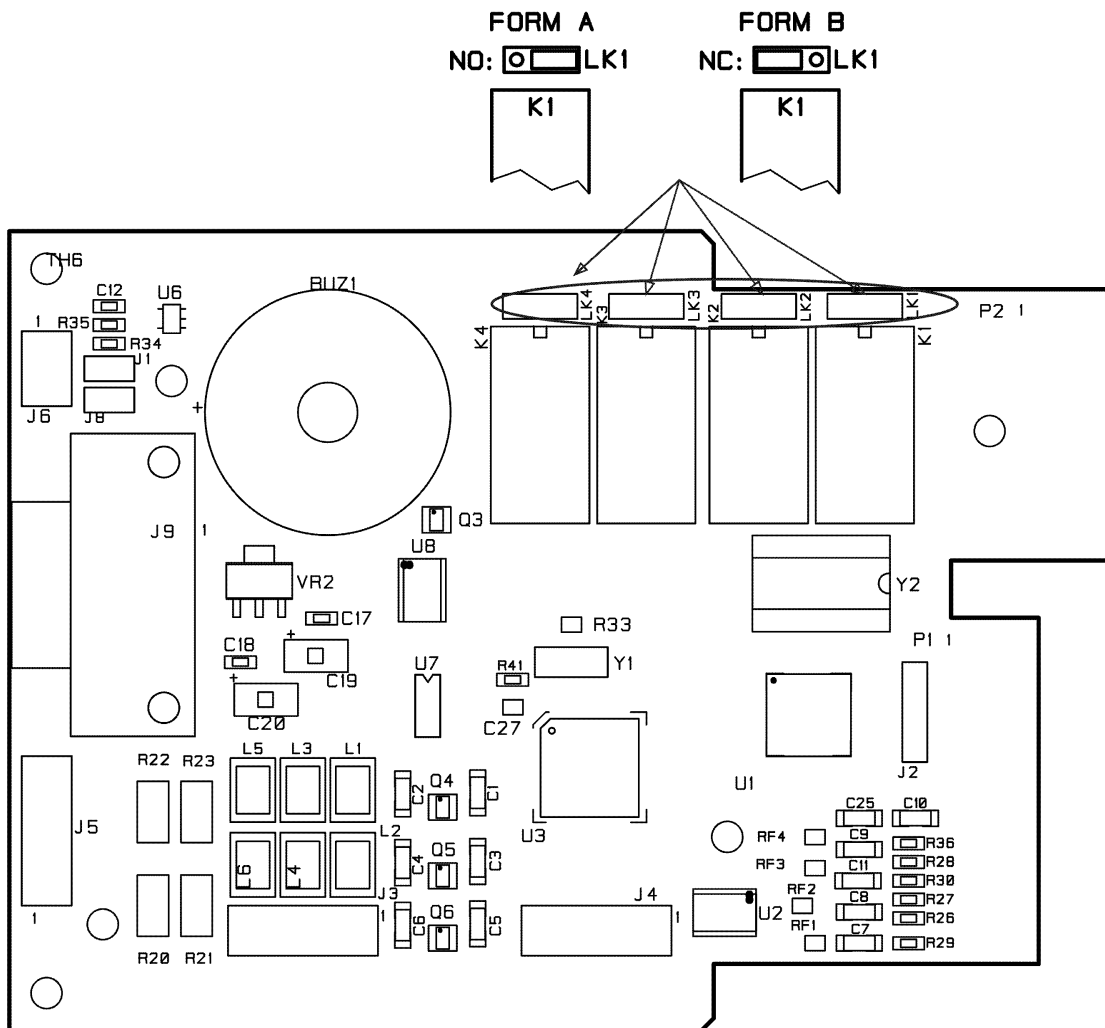

Common Service Pushbutton Assemblies

The Common Service Module can be provided with Integral Pushbuttons (Option INTB or LPPB) or no integral pushbuttons (Option NPB). In all cases, external pushbuttons can be connected to the rear of the unit.

Option INTB uses pushbuttons on the lower right Common Service Cell and Option LPPB has pushbuttons mounted on the Annunciator bezel which frees up the lower right Common Service cell for a one or two point window.

Option INTB



Option LPPB



Both options provide Silence, Acknowledge, Test and Reset Pushbuttons. Also, The Pushbutton Assemblies include 4 diagnostic indicators.

- System Status
Monitors all internal diagnostics including power. (Green is OK, Red is Fault)
- LED Fail
Monitors all of the LED's for a short or open circuit. To identify the failed LED, press the Test Pushbuttons and see which cell has a failed LED.
- Remote Comm
Flashes whenever the communications are being used via Modbus or DNP
- Ground Fault
Used with the Ground Fault Option Module. Indicates the presence of a positive or negative fault to ground in the field input wiring.

Communication Modules

The optional Communication Modules plug directly into the CSM Module through card slot 2 and provide either a serial or Ethernet output. Only one Communication Module per CSM is allowed.

The Serial port will be active when the 'SPT' option is included in the model number code and the Ethernet port will be active when option 'ETH' is included in the model number code. Systems may contain both Serial and Ethernet communications when options 'SPT' and 'ETH' are included in the model number. To verify which board you have, compare it to the pictures on the following pages.

Serial/Ethernet Communication Module

The optional Serial/Ethernet Communication Module can be equipped for Serial, Ethernet or both simultaneously for dual or redundant communications.

The Serial Communications (Option SPT) provides RS-232/485 serial data using Modbus, DNP or ASCII protocols.

The Modbus protocol can be configured as Modbus RTU or Modbus ASCII and supports operation as a Master or Slave device. It can transmit alarm status from the field contacts or receive alarms through the protocol.

The DNP protocol supports operation as a Slave device transmitting the alarm status of the field contacts.

The ASCII protocol is only used in conjunction with the Time Stamping of Alarms Option (SER or SERFR) continually streaming any alarm or return to normal events. When Modbus or DNP is used with the Time Stamping of Alarms Option (SER or SERFR), it provides the time and date of the alarms and return to normal events.

The Serial Communication Module can be configured via jumpers for RS-232/485 communications. It can be configured via software for all Modbus and DNP settings.

The Ethernet Communications (Option ETH) is used for simultaneous communications using Modbus TCP/IP or DNP protocols.

The Modbus TCP/IP protocol can be configured for Master or Slave operation. When configured as a Modbus Slave, it can communicate to multiple Modbus Master devices simultaneously via TCP/IP connectivity. When configured as a Modbus Master, it can communicate to a single Modbus Slave device. The Modbus protocol is used to transmit the alarm status or can be used to receive alarms for annunciating the windows. When receiving alarms, the digital inputs are not required, unless the two operate in parallel with an alarm generated from either a digital input or Modbus data.

The DNP protocol supports operation as a Slave device transmitting the alarm status of the field contacts.

When Modbus or DNP is used with the Time Stamping of Alarms Option (SER or SERFR), it provides the time and date of the alarms and return to normal events.

All configuration of serial and Ethernet connections is done via configuration software.

This module is a 2 board assembly; a carrier card, and a communications card. This 2 board assembly mounts to the CSM module.

Carrier card

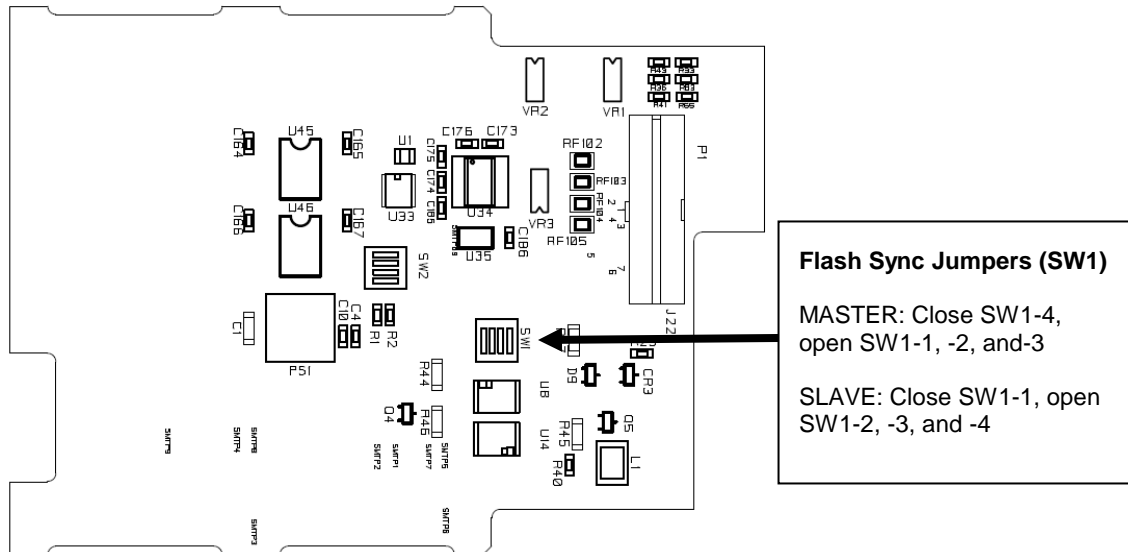

Communications card:

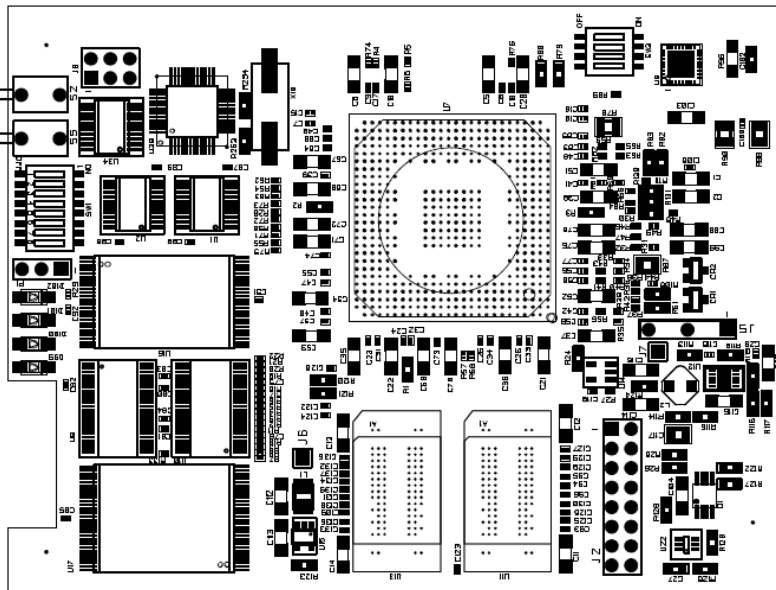

There is one hardware setting on the carrier card for flash sync master/slave. Only one unit should be set as a master for the flash sync function. This function is set via SW1.

Master: SW1-1 on, SW1-2, SW1-3, and SW1-4 off

Slave: SW1-1 SW1-2 and SW1-3 off, and SW1-4 on

To access this setting remove power from the system and remove the CSM and Communication board assembly from the annunciator. Remove the three screws that are used to mount the communications module to the carrier card.

There are no user configurable settings on the communication card.

Ground Fault Detector Module

The optional Ground Fault Detector Module can be installed in Card Slot 5 of any cell that does not contain an Integral Power Supply or IRIG-B Module. It can be calibrated for sensitivity via the front. The Ground Fault Detector has jumpers selectable for the Field Contact Voltage used within the system. It only operates with 24, 48 or 125VDC.

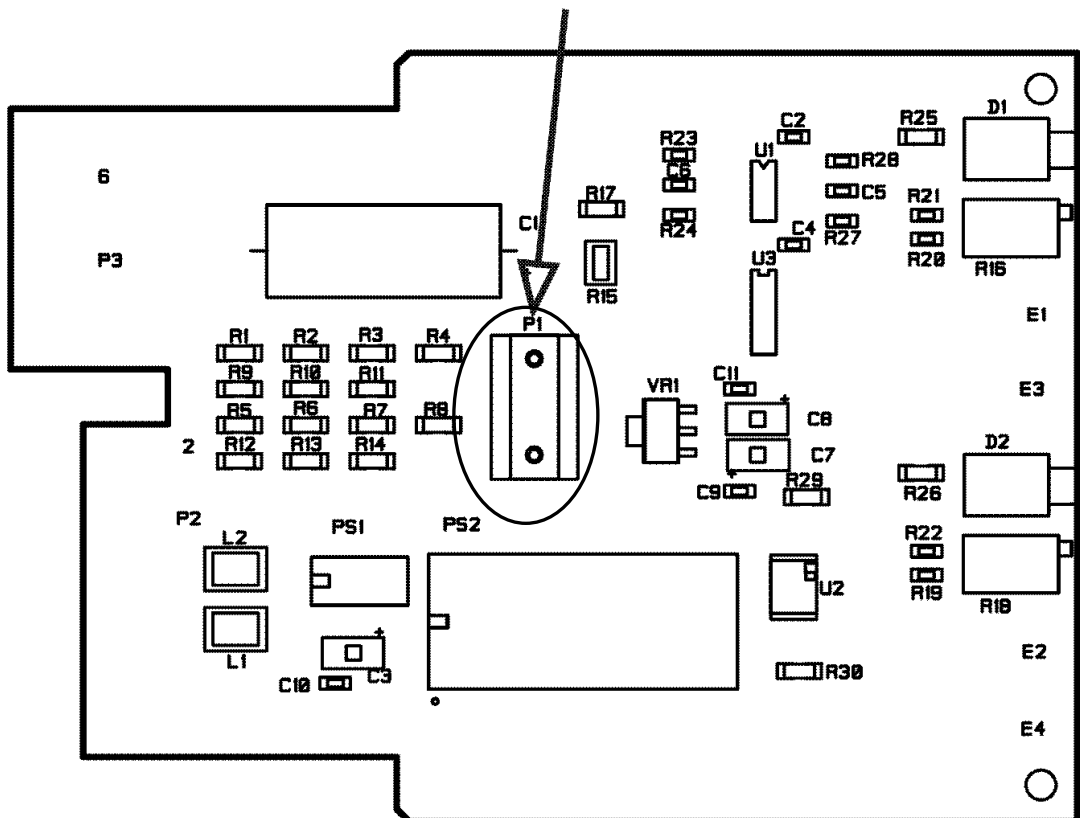
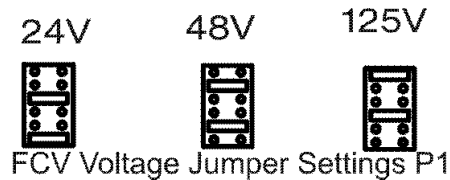

Power Supply Modules

Several Integral Power Supply Modules are available depending on the system input power, size of the system and field contact voltage selection. There are no configurable jumpers on these modules. Refer to the power connection in this manual for the power supply images.

Field Contact Voltage Supply Modules

Several Integral FCV Supply Modules are available depending on the system input power and field contact voltage selection. There are no configurable jumpers on these modules. Refer to the power connection in this manual for the power supply images.

IRIG-B Module

The optional IRIG-B Module is used for External time synchronization of the SER Option. This must be installed in Card Slot 5 of the CSM Cell. (When used, the Integral Power Supply must be moved to a different cell.)

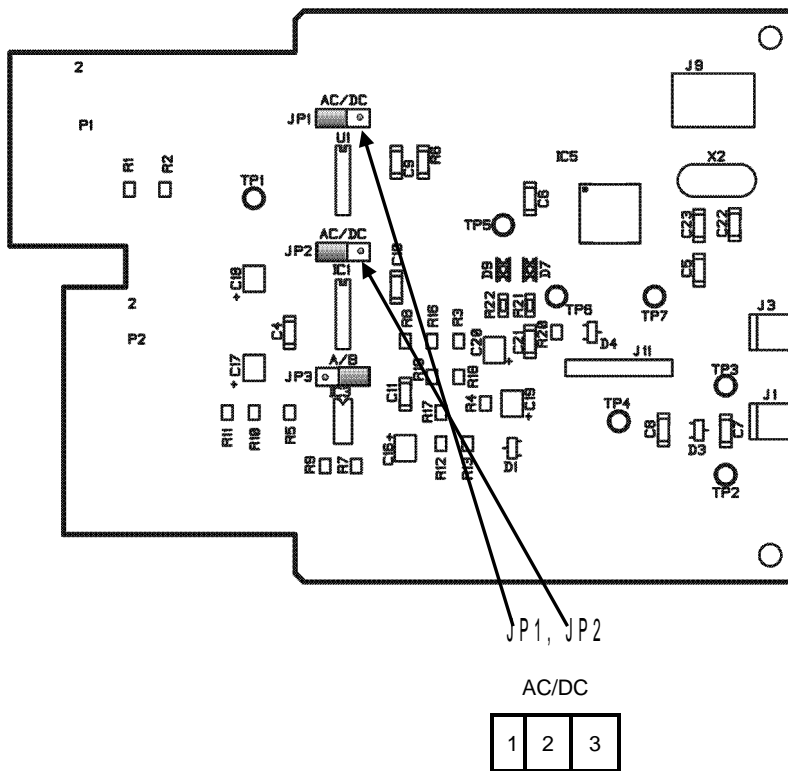

IRIG-B MODULE SETUP

	Jumper Position			INPUT TYPE
	1	2	3	
JP1	1	2	3	Modulated(AC)
JP2	1	2	3	
JP1	1	2	3	Demodulated (DC)
JP2	1	2	3	

INSTALLATION

MOUNTING

The system is designed for Panel Mounting and 19" Rack Mounting, Other mounting methods such as NEMA Enclosures and Surface or Wall Mounting will have additional details and drawings provided by the factory.

Caution must be exercised when installing this, or any other type of equipment into racks or panels. Ensure that all equipment is properly secured using the specified hardware in accordance with equipment manufacturer's specifications.

Panel Mounting(option PM, PC)

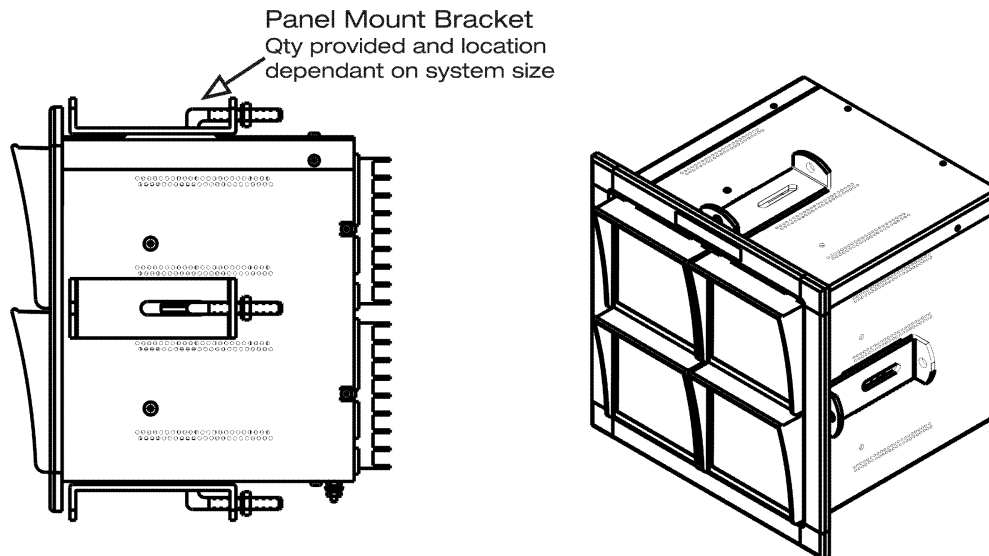

The dimensions given in the tables below refer to the size of the panel cut out required for mounting and the front bezel height and width. The height and width are related to the number of cells in the system. Dimensions shown are in inches (mm).

# of Cells High	# of Cells Wide	Overall Height or Overall Width	Panel Cut-Out Height or Panel Cut-Out Width
1	---	5.0 (127)	4.06 (103)
2	2	8.47 (215)	7.53 (191)
3	3	11.94 (303)	11.0 (279)
4	4	15.40 (391)	14.47 (368)
5	5	18.88 (479)	17.94 (456)
6	6	22.34 (568)	21.41 (544)
7	7	25.81 (656)	24.88 (632)
8	8	29.28 (744)	28.34 (720)
9	9	32.75 (832)	31.81 (808)
10	10	36.22 (920)	35.28 (896)
11	11	39.69 (1008)	38.75 (984)
12	12	43.16 (1096)	42.22 (1072)
13	13	46.63 (1184)	45.69 (1161)

Tolerance on all cut out dimensions is 0.0625 inches (1.5mm)

Example: A 3H x 4W Annunciator has a cut-out height of 11.0 and a cut-out width of 14.47.

Annunciator Depth (Behind Panel)	Inches	Mm
Maximum depth w/out rear cover	6.75	171
Maximum depth w/ rear cover	10.00	254

Minimum mounting panel thickness: 18 GA Galvanneal, 0.072 inches, 1.83 mm.

For system installation perform the following steps:

- 1 Mark cutout dimensions on the surface where the annunciator is to be mounted, keeping in mind that the assembly may rest on the sill of the cutout.

NOTE: Allow a minimum of 6 inches (150 mm) above the unit and behind the panel for proper ventilation.
- 2 Cut out and remove panel material.
- 3 Temporarily remove the panel mounting clamps and Install the annunciator assembly through the panel cut-out (from the front of the panel). Position within the cutout so that the weight is taken at the bottom of the unit.
- 4 From the rear of the panel, replace the annunciator mounting clamps along the bottom then top and sides screws to “finger tight” check the front of panel alignment on panel face etc
- 5 Fully tighten the mounting clamps.

19" Rack Mounting (option RK)

The dimensions given in the tables below refer to the height of the 19" Rack based on the number of Cells High. In all configurations, the Annunciator will be 5 cells wide to maintain the 19" rack width. Dimensions shown are in inches (mm)

# of Cells High	Overall Rack Height		
	Inches	mm	U Rack
1	5.25	133.35	3U
2	8.75	222.25	5U
3	12.25	311.15	7U
4	15.75	400.05	9U
5	19.25	488.95	11U
6	22.75	577.85	13U
7	26.25	666.75	15U
8	29.75	755.65	17U
9	33.25	844.55	19U
10	36.75	933.45	21U
11	40.25	1022.35	23U
12	43.75	1111.25	25U
13	47.25	1200.15	27U

Annunciator Depth	Inches	mm
Maximum depth	6.8	172.72

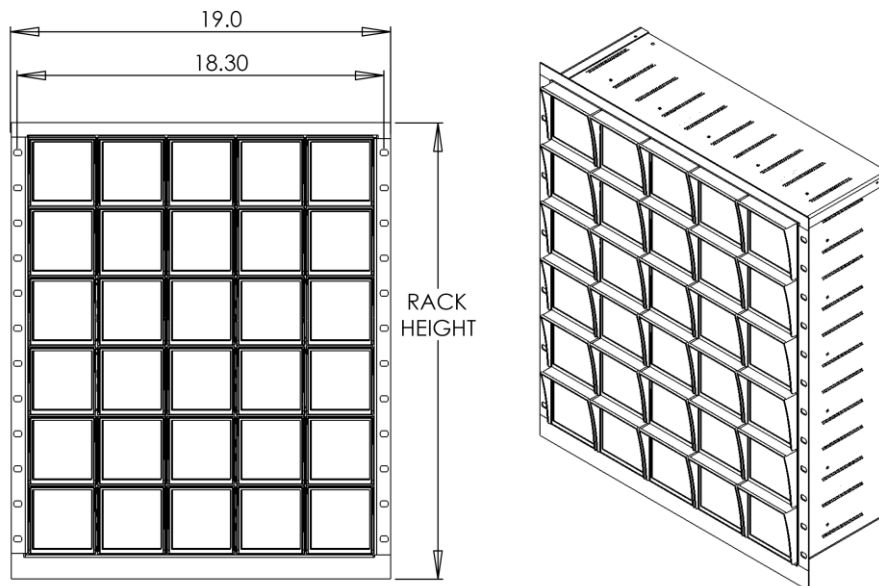

For system installation, perform the following steps:

Allow a minimum of 6 inches (150 mm) above the unit and behind the panel for proper ventilation.

- 1 Slide the annunciator assembly into the rack (from the front of the rack).
- 2 Secure using the recommended fixing screws into the rack mount rails.

Nema Enclosure (option N4, N4PB)

The dimensions given in the chart below are for both options (N4, N4PB). Only the N4 is shown. Both options may also include a horn mounted on the face of the door. The Annunciator is mounted on a swing frame behind the door and is viewed through a window installed in the door. The swing frame allows access to the wiring behind the Annunciator.

Caution: In order to prevent tipping, the NEMA enclosure must be securely fastened to a surface before attempting to open the door or the swing panel.

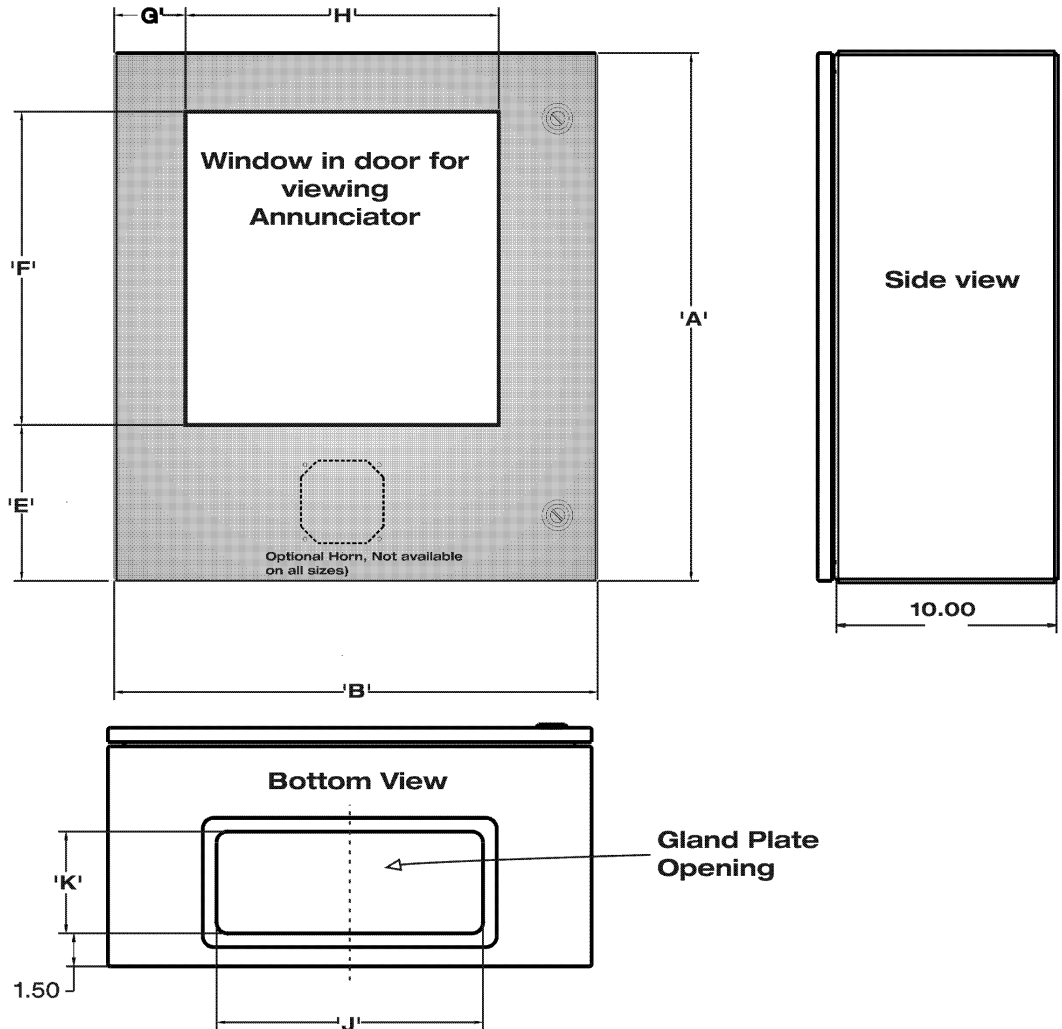

PART #	A	B	E	F	G	H	J	K
1 or 2 H X 3 or 4W	16.00	22.00	6.03	7.32	3.25	14.25	12.13	4.63
1 or 2 H X 5 or 6W	16.00	30.00	6.03	7.32	4.31	21.19	12.13	4.63
1 or 2 H X 7 or 8W	16.00	36.00	5.63	7.32	3.47	28.03	19.63	4.63
3 or 4 H X 3 or 4W	24.00	22.00	7.09	14.25	3.25	14.25	12.13	4.63
3 or 4 H X 5 or 6W	24.00	30.00	7.09	14.25	4.31	21.19	12.13	4.63
3 or 4 H X 7 or 8W	24.00	36.00	6.75	14.25	3.47	28.03	19.63	4.63
5 or 6 H X 3 or 4W	32.00	22.00	8.15	21.19	3.25	14.25	12.13	4.63
5 or 6 H X 5 or 6W	32.00	30.00	8.15	21.19	4.31	21.19	12.13	4.63
5 or 6 H X 7 or 8W	32.00	36.00	7.75	21.19	3.47	28.03	19.63	4.63

Surface (Wall) Mounting (option S)

Mounting to a wall or other surface. The annunciator is hinged on one side to allow access to the terminal blocks in the rear of the unit. The hinge may be moved to the right side of the annunciator by removing the brackets, rotating them and re-mounting them to the opposite side(s). Refer to table for available sizes and dimensions. All mounting holes sized for ¼ -20 hardware.

A minimum of 10" of swing clearance is required on the hinge side of the annunciator.

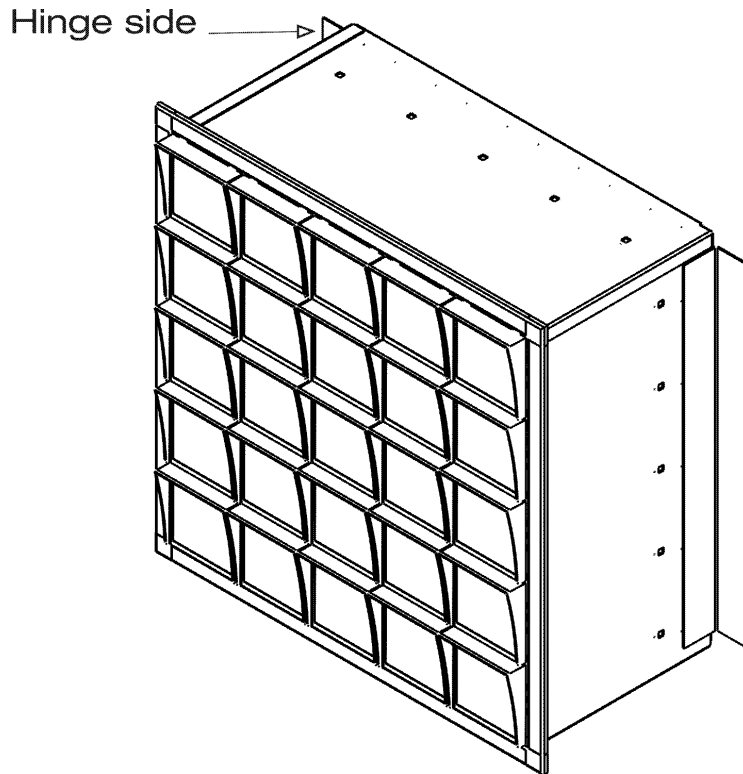

Refer to the following chart and the figures on the following page for mounting dimensions.

Dimension	ANNUNCIATOR SIZE									Dimension
	1H	2H	3H	4H	5H	2W	3W	4W	5W	
A	3.65	7.12	10.59	14.06	17.53	X				
B	4.93	8.40	11.87	15.34	18.81					
C	0.40	1.12	1.12	1.12	1.12					
D	1.90	4.59	4.59	4.59	4.59					
E	-----	-----	8.05	8.05	8.05					
F	-----	-----	-----	11.52	11.52					
G	-----	-----	-----		14.99					
H	2.23	5.70	9.17	12.64	16.11					
	X					8.74	12.21	15.68	19.15	J
						8.39	11.86	15.33	18.80	K
						10.24	13.71	17.18	20.65	L

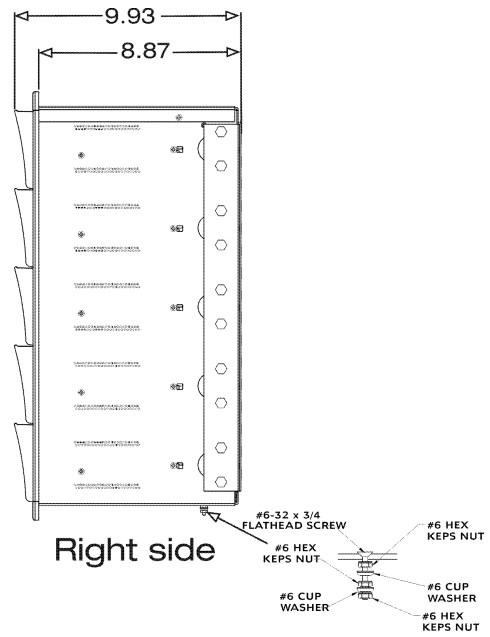
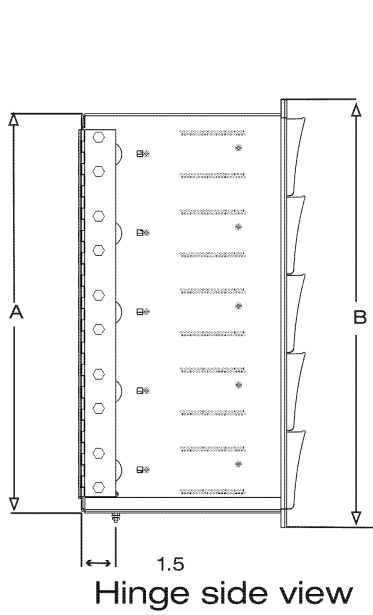
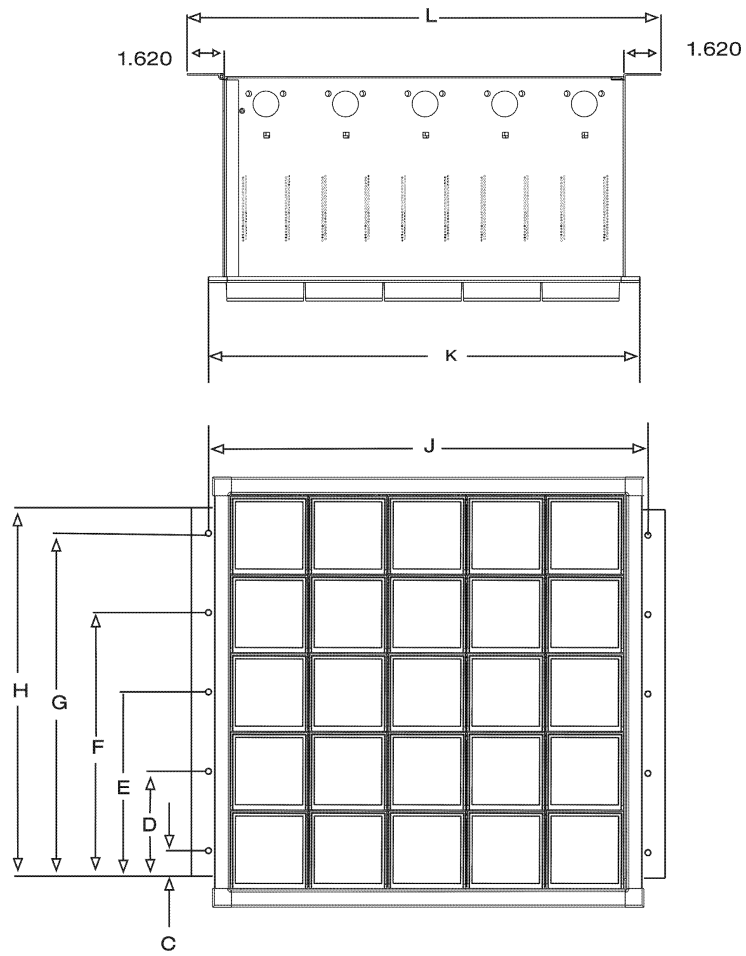

Weather Tight NEMA front Cover (option NCB, NCT)

This option provides for a NEMA rated front cover for the panel-mounted option, it consists of a swing frame and a weather tight door. Two options are available; the NCB option uses $\frac{1}{4}$ bolts to secure the door to the panel; the NCT option has a T-Handle for securing the door. Both options use $\frac{1}{4}$ -20 mounting bolts to secure the swing panel to the mounting surface. Refer to the charts following for the mounting hole location and over-all size of the door.

Refer to the Panel mount option for the cutout dimensions for the annunciator, mount the door option, centered on the hole. Mount the annunciator thru the panel hole and secure with the mounting clamps as described in the panel mount installation instructions (option PM, PC)

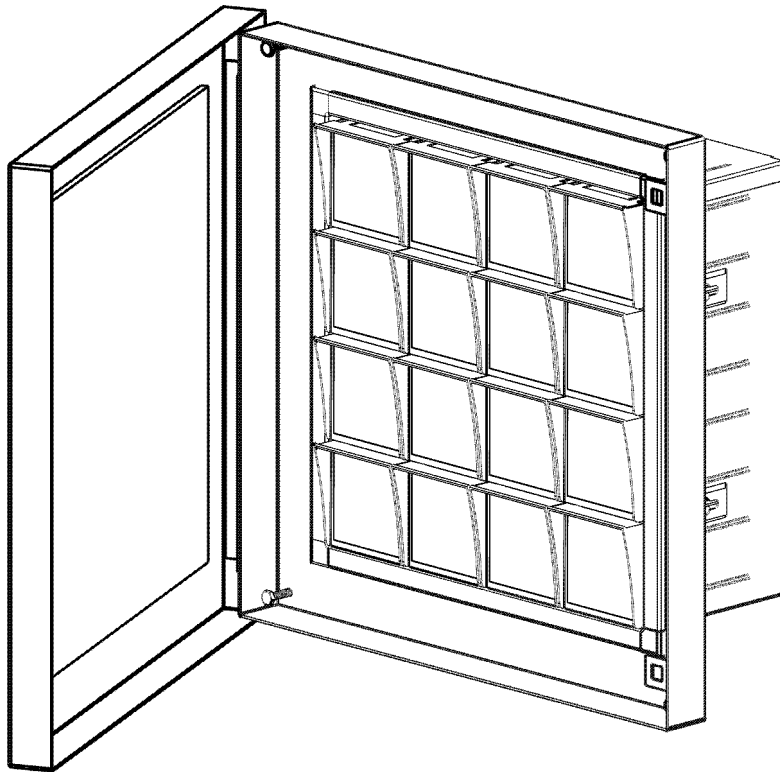

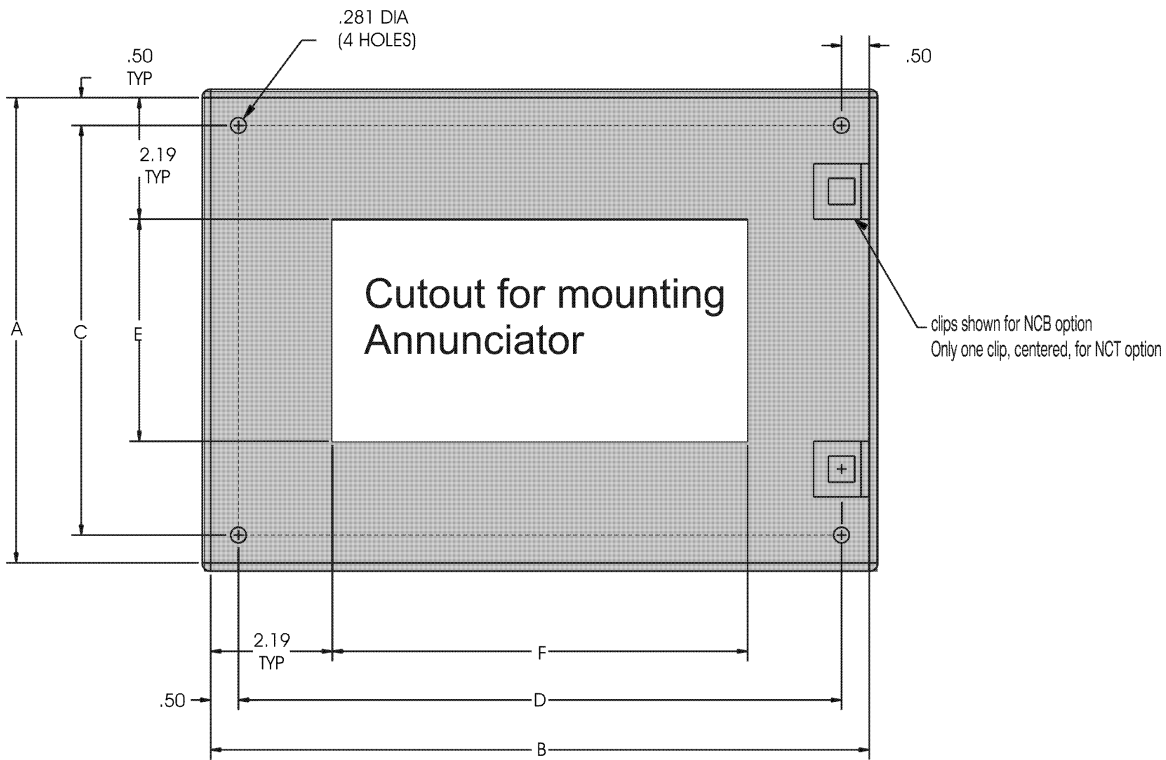

# OF CELLS HIGH	# OF CELLS WIDE	DIM A	DIM B	DIM C	DIM D	DIM E	DIM F
1	2	8.38	11.84	7.38	10.84	4.00	7.47
1	3	8.38	15.31	7.38	14.31	4.00	10.94
1	4	8.38	18.78	7.38	17.78	4.00	14.41
1	5	8.38	22.25	7.38	21.25	4.00	17.88
1	6	8.38	25.72	7.38	24.72	4.00	21.34
1	7	8.38	29.19	7.38	28.19	4.00	24.81
1	8	8.38	32.66	7.38	31.66	4.00	28.28
1	9	8.38	36.13	7.38	35.13	4.00	31.75
1	10	8.38	39.59	7.38	38.59	4.00	35.22
2	2	11.84	11.84	10.84	10.84	7.47	7.47
2	3	11.84	15.31	10.84	14.31	7.47	10.94
2	4	11.84	18.78	10.84	17.78	7.47	14.41
2	5	11.84	22.25	10.84	21.25	7.47	17.88
2	6	11.84	25.72	10.84	24.72	7.47	21.34
2	7	11.84	29.19	10.84	28.19	7.47	24.81
2	8	11.84	32.66	10.84	31.66	7.47	28.28
2	9	11.84	36.13	10.84	35.13	7.47	31.75
2	10	11.84	39.59	10.84	38.59	7.47	35.22
3	2	15.31	11.84	14.31	10.84	10.94	7.47
3	3	15.31	15.31	14.31	14.31	10.94	10.94
3	4	15.31	18.78	14.31	17.78	10.94	14.41
3	5	15.31	22.25	14.31	21.25	10.94	17.88
3	6	15.31	25.72	14.31	24.72	10.94	21.34
3	7	15.31	29.19	14.31	28.19	10.94	24.81
3	8	15.31	32.66	14.31	31.66	10.94	28.28
3	9	15.31	36.13	14.31	35.13	10.94	31.75
3	10	15.31	39.59	14.31	38.59	10.94	35.22

# OF CELLS HIGH	# OF CELLS WIDE	DIM A	DIM B	DIM C	DIM D	DIM E	DIM F
4	2	18.78	11.84	17.78	10.84	14.41	7.47
4	3	18.78	15.31	17.78	14.31	14.41	10.94
4	4	18.78	18.78	17.78	17.78	14.41	14.41
4	5	18.78	22.25	17.78	21.25	14.41	17.88
4	6	18.78	25.72	17.78	24.72	14.41	21.34
4	7	18.78	29.19	17.78	28.19	14.41	24.81
4	8	18.78	32.66	17.78	31.66	14.41	28.28
4	9	18.78	36.13	17.78	35.13	14.41	31.75
4	10	18.78	39.59	17.78	38.59	14.41	35.22
5	2	22.25	11.84	21.25	10.84	17.88	7.47
5	3	22.25	15.31	21.25	14.31	17.88	10.94
5	4	22.25	18.78	21.25	17.78	17.88	14.41
5	5	22.25	22.25	21.25	21.25	17.88	17.88
5	6	22.25	25.72	21.25	24.72	17.88	21.34
5	7	22.25	29.19	21.25	28.19	17.88	24.81
5	8	22.25	32.66	21.25	31.66	17.88	28.28
5	9	22.25	36.13	21.25	35.13	17.88	31.75
5	10	22.25	39.59	21.25	38.59	17.88	35.22
6	2	25.72	11.84	24.72	10.84	21.34	7.47
6	3	25.72	15.31	24.72	14.31	21.34	10.94
6	4	25.72	18.78	24.72	17.78	21.34	14.41
6	5	25.72	22.25	24.72	21.25	21.34	17.88
6	6	25.72	25.72	24.72	24.72	21.34	21.34
6	7	25.72	29.19	24.72	28.19	21.34	24.81
6	8	25.72	32.66	24.72	31.66	21.34	28.28
6	9	25.72	36.13	24.72	35.13	21.34	31.75
6	10	25.72	39.59	24.72	38.59	21.34	35.22
7	2	29.19	11.84	28.19	10.84	24.81	7.47
7	3	29.19	15.31	28.19	14.31	24.81	10.94
7	4	29.19	18.78	28.19	17.78	24.81	14.41
7	5	29.19	22.25	28.19	21.25	24.81	17.88
7	6	29.19	25.72	28.19	24.72	24.81	21.34
7	7	29.19	29.19	28.19	28.19	24.81	24.81
7	8	29.19	32.66	28.19	31.66	24.81	28.28
7	9	29.19	36.13	28.19	35.13	24.81	31.75
7	10	29.19	39.59	28.19	38.59	24.81	35.22
8	2	32.66	11.84	31.66	10.84	28.28	7.47
8	3	32.66	15.31	31.66	14.31	28.28	10.94
8	4	32.66	18.78	31.66	17.78	28.28	14.41
8	5	32.66	22.25	31.66	21.25	28.28	17.88
8	6	32.66	25.72	31.66	24.72	28.28	21.34
8	7	32.66	29.19	31.66	28.19	28.28	24.81
8	8	32.66	32.66	31.66	31.66	28.28	28.28
8	9	32.66	36.13	31.66	35.13	28.28	31.75
8	10	32.66	39.59	31.66	38.59	28.28	35.22
9	2	36.13	11.84	35.13	10.84	31.75	7.47
9	3	36.13	15.31	35.13	14.31	31.75	10.94
9	4	36.13	18.78	35.13	17.78	31.75	14.41
9	5	36.13	22.25	35.13	21.25	31.75	17.88
9	6	36.13	25.72	35.13	24.72	31.75	21.34
9	7	36.13	29.19	35.13	28.19	31.75	24.81
9	8	36.13	32.66	35.13	31.66	31.75	28.28
9	9	36.13	36.13	35.13	35.13	31.75	31.75
9	10	36.13	39.59	35.13	38.59	31.75	35.22

# OF CELLS HIGH	# OF CELLS WIDE	DIM A	DIM B	DIM C	DIM D	DIM E	DIM F
10	2	102	102	102	102	102	102
10	3	39.59	15.31	38.59	14.31	35.22	10.94
10	4	39.59	18.78	38.59	17.78	35.22	14.41
10	5	39.59	22.25	38.59	21.25	35.22	17.88
10	6	39.59	25.72	38.59	24.72	35.22	21.34
10	7	39.59	29.19	38.59	28.19	35.22	24.81
10	8	39.59	32.66	38.59	31.66	35.22	28.28
10	9	39.59	36.13	38.59	35.13	35.22	31.75
10	10	39.59	39.59	38.59	38.59	35.22	35.22

WIRING

All wiring connections are made to the rear of the unit using barrier style terminal blocks. All Field Contact Inputs, Relay Outputs and Power Connections are made to Terminal Blocks that have a #6 screw, which will accept a solid or stranded wire from 12-22 AWG, with or without ring & spade lugs. The Pushbutton Controls and Flash Synchronization connections are made to Terminal Blocks that have a #6 screw which will accept a solid or stranded wire from 14-22 AWG, with or without ring & spade lugs.

Ensure that a proper earth ground connection is made to the protective earth ground stud.



Note for Relay Output Wiring: When option RR (Repeat relay) is installed, and 120 Vac is switched by the contact. All output wiring in any individual cell must be wired to the same phase of the service.

Input Wiring

The input wiring is determined by the number of alarms (or windows per cell) and the number of I/O Cards. The available configurations are:

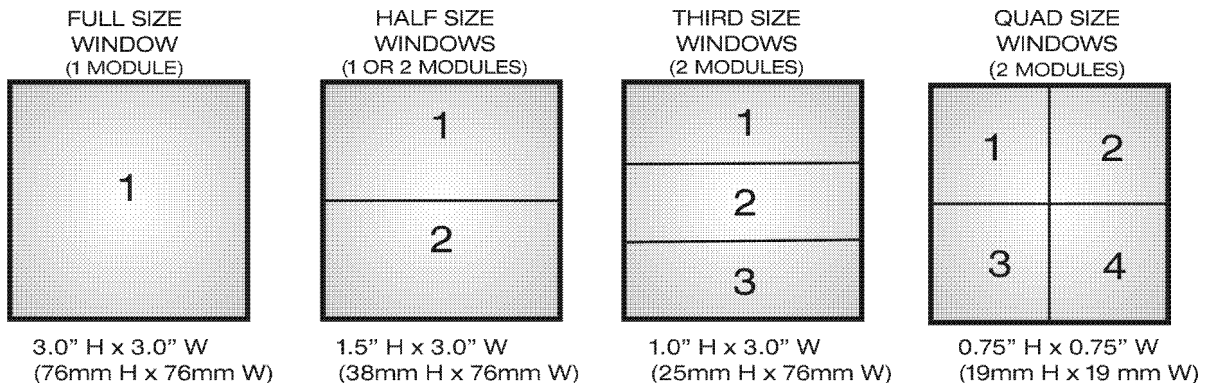

The I/O cards can support up to two inputs, however, certain options limit that to one input per card as shown with the Half Size Window above.

Common Field Contact Voltage

The I/O cards are typically set up for a common system-wide Field Contact Voltage (FCV). In this case, terminals 2 and 4 of each I/O Terminal Block are connected to the FCV, which is internally bussed throughout the system to the Power Supply Terminal Block, Terminal 3. As shown in the Power Supply Drawings, an external Field Contact Voltage Supply can be connected to the Power Supply Terminal Block for distribution throughout the system. In systems where the FCV is generated within the Annunciator, it is already distributed throughout the Annunciator. Each I/O card FCV connection is internally fused preventing any overload from the field. Removing an I/O card will disconnect the FCV at the terminal block for that card only.

Isolated Field Contact Voltage

The I/O cards can be jumpered to remove the system wide bussing and replace with an individual FCV connection per input. This is shown on the drawings as well.

**Input / Relay Wiring for Full Size Windows
(using one I/O Card)**

**Model Code
Window Size 1E**

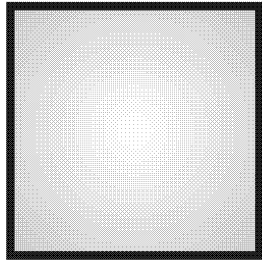

(Front View)

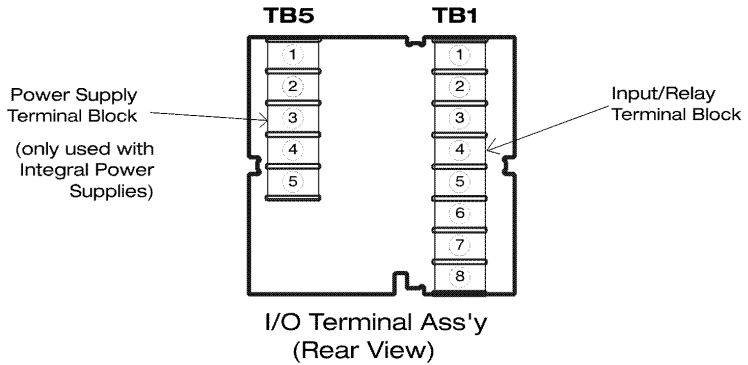

**INPUT WIRING
Common FCV**

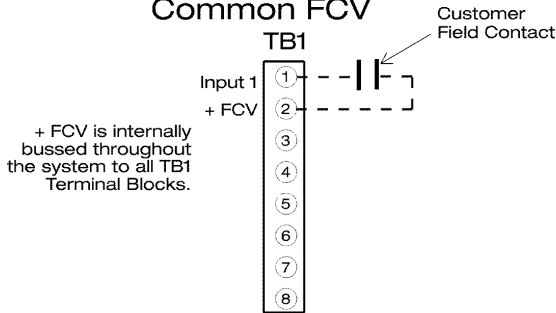

**INPUT WIRING
Isolated FCV**

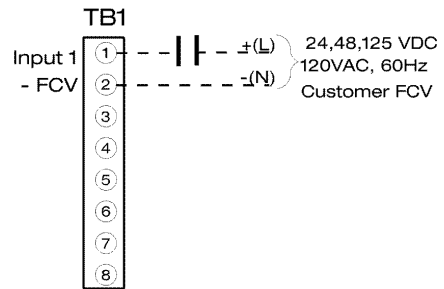

**REPEAT RELAY WIRING
Option RR and 2RR**

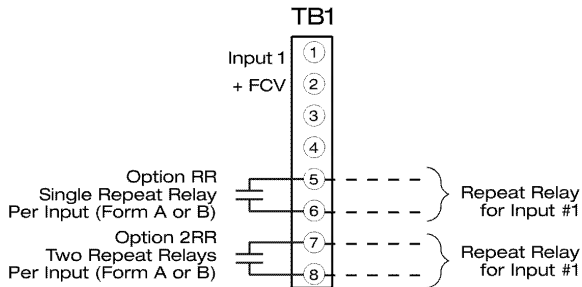

**REPEAT RELAY WIRING
Option FRC**

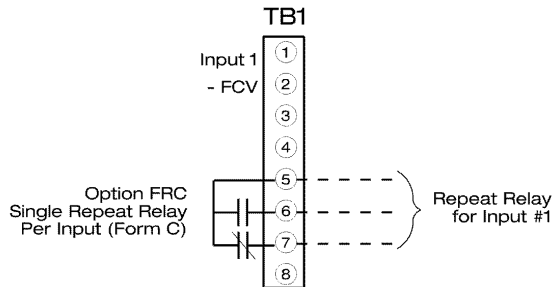

Input/Relay Wiring For Half Size Windows (using one I/O Card)

Model Code Window Size 2

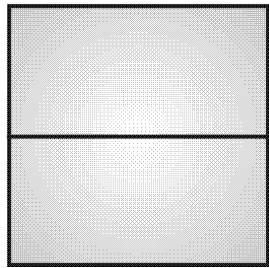

(Front View)

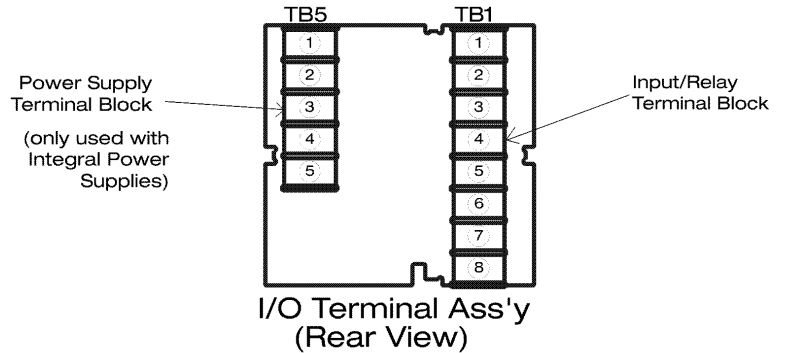

INPUT WIRING Common FCV

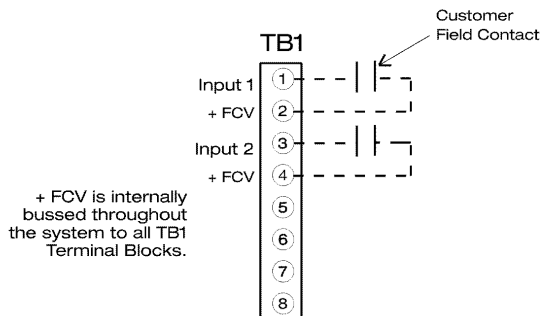

INPUT WIRING Isolated FCV

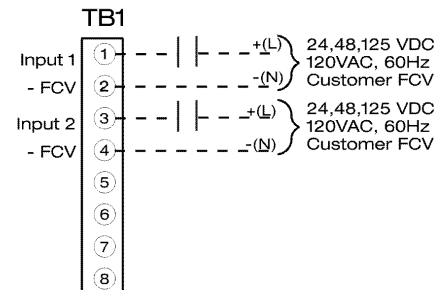

REPEAT RELAY WIRING Option RR

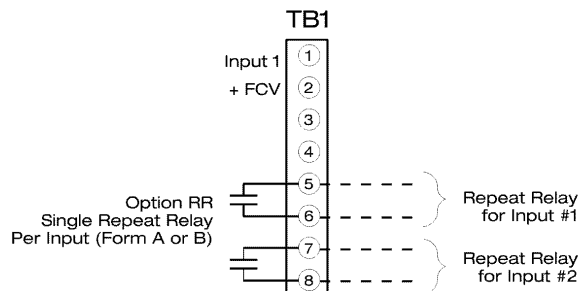

Input/Relay Wiring For Half Size Windows (using one I/O Card)

Model Code Window Size 2E

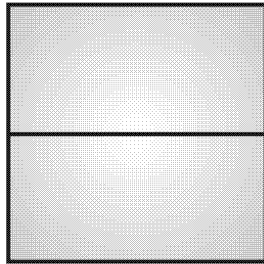

(Front View)

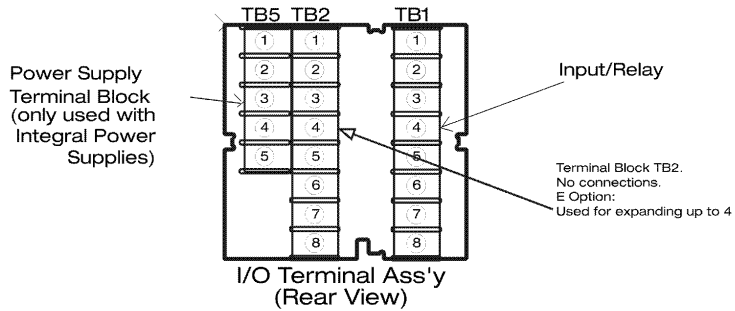

INPUT WIRING Common FCV

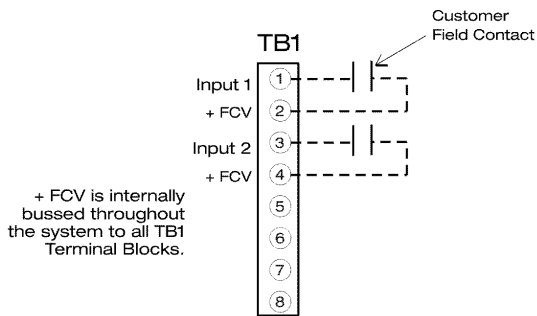

INPUT WIRING Isolated FCV

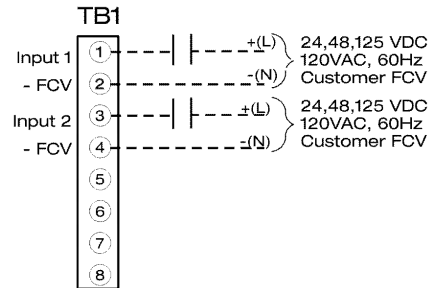

REPEAT RELAY WIRING Option RR

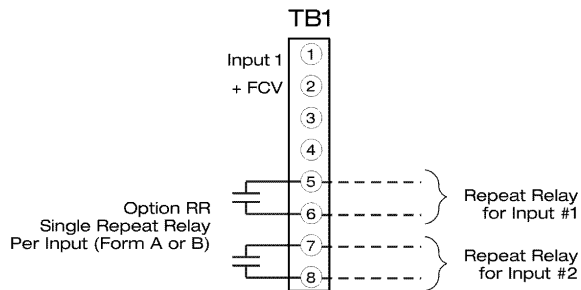

Input Wiring with Half Size Windows

Model Code Window Size 2S

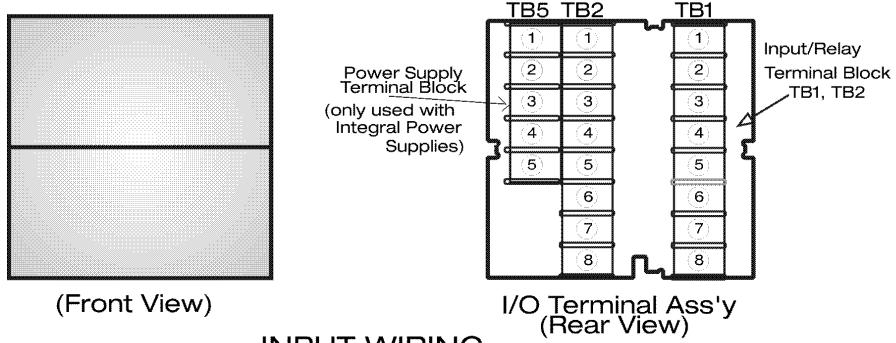

INPUT WIRING Common FCV

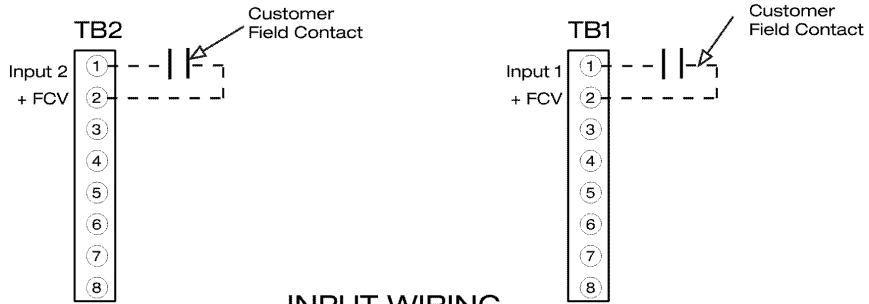

INPUT WIRING Isolated FCV

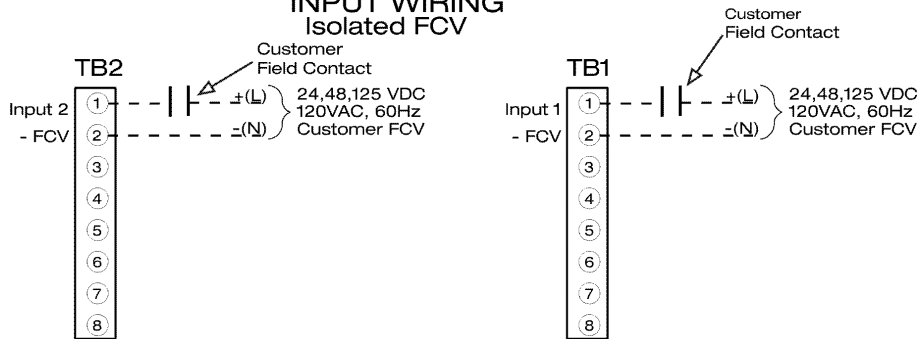

(using two I/O Cards)

**Repeat Relay Wiring for Half Size Windows
(using two I/O Cards)**

Model Code
Window Size 2S

REPEAT RELAY WIRING

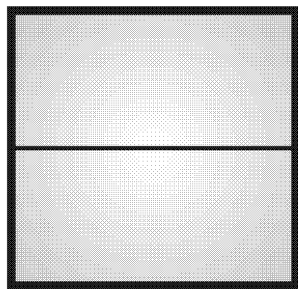

(Front View)

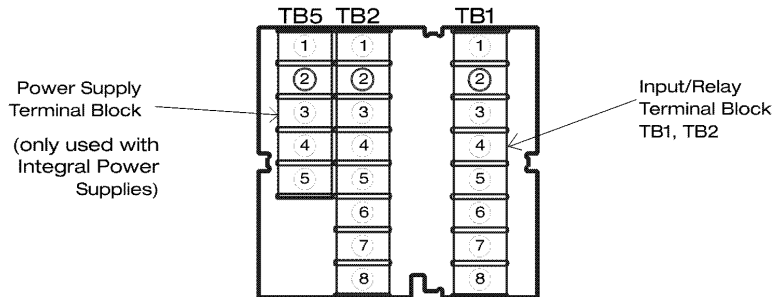

I/O Terminal Ass'y
(Rear View)

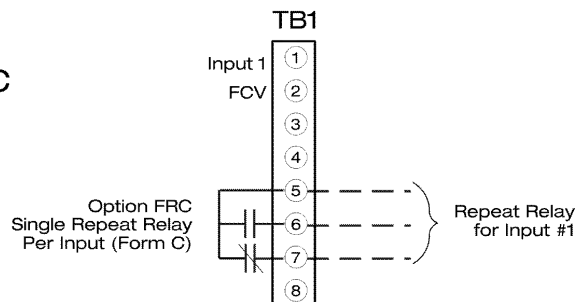
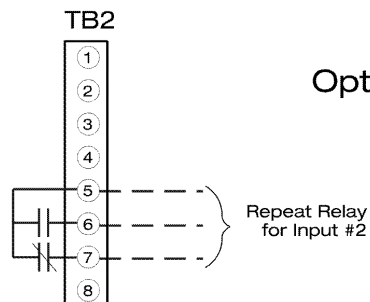
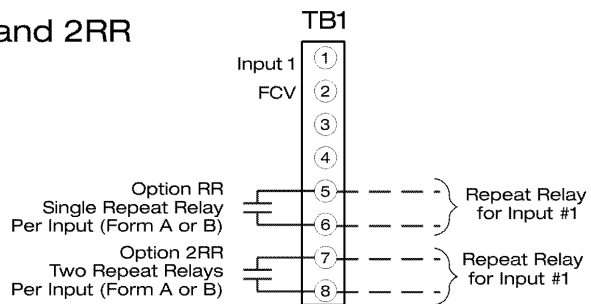
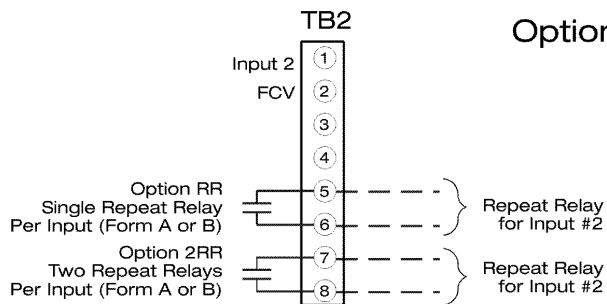

Input/Relay Wiring for Third Size Windows
 (using two I/O Cards)

Model Code
 Window Size 3

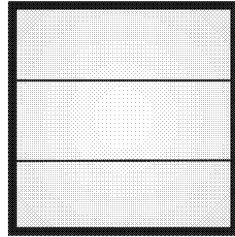

(Front View)

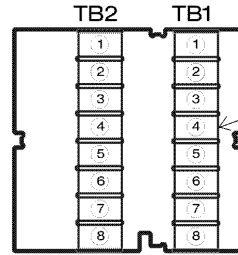

I/O Terminal Ass'y
 (Rear View)

Input/Relay
 Terminal Block

INPUT WIRING
 Common FCV

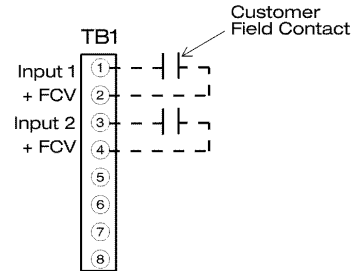
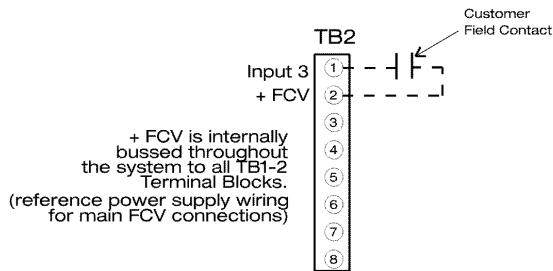

INPUT WIRING
 Isolated FCV

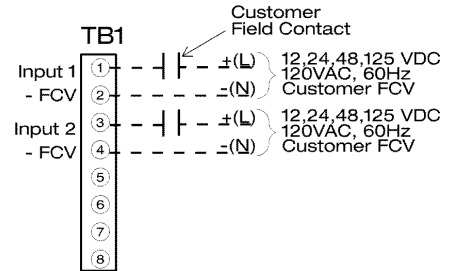
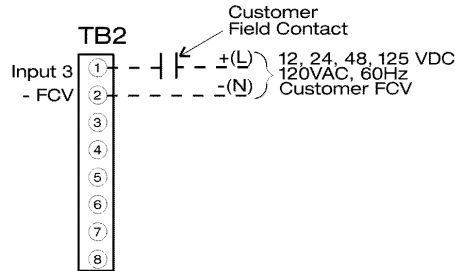

REPEAT RELAY WIRING
 Option RR

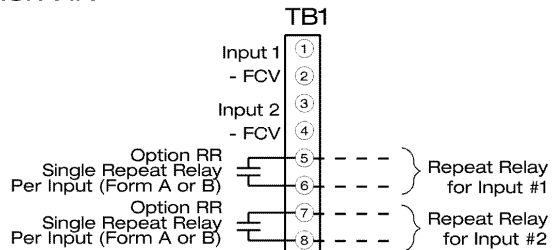
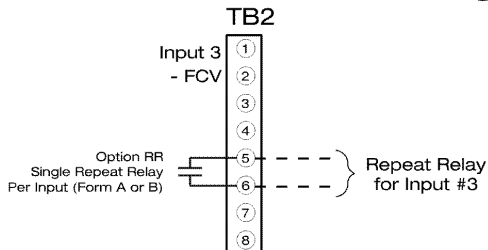

Input/Relay Wiring for Quad Size Windows (using two I/O Cards)

Model Code Window Size 4

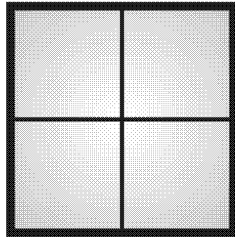

(Front View)

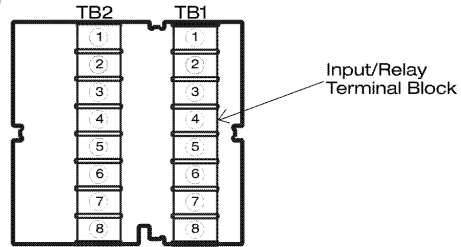

I/O Terminal Ass'y
(Rear View)

INPUT WIRING Common FCV

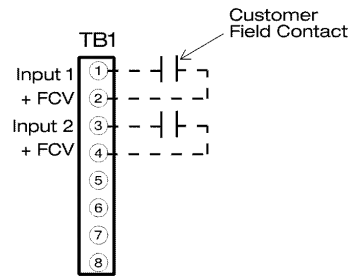
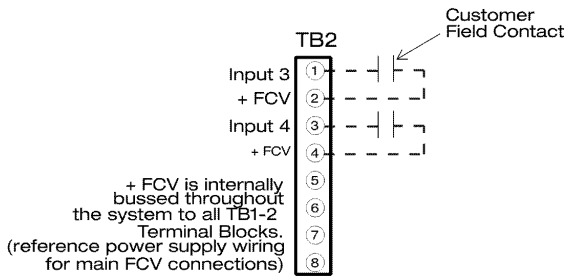

INPUT WIRING Isolated FCV

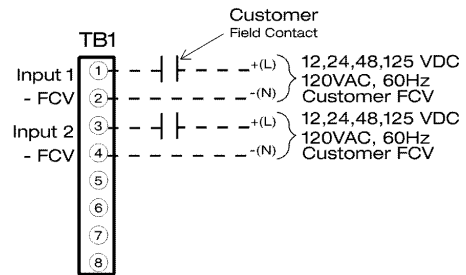
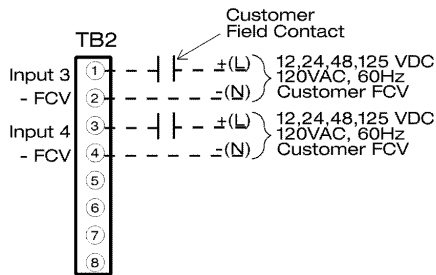

REPEAT RELAY WIRING Option RR

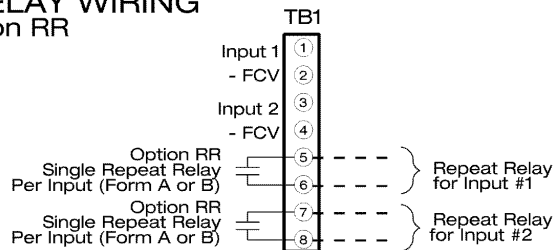
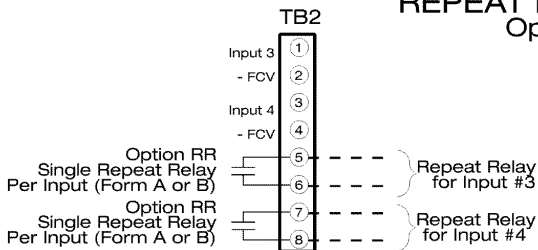

Common Service Cell Wiring (with Integral Pushbuttons)

Model Code
INTB

Integral Pushbuttons

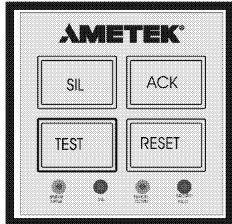

(front view)

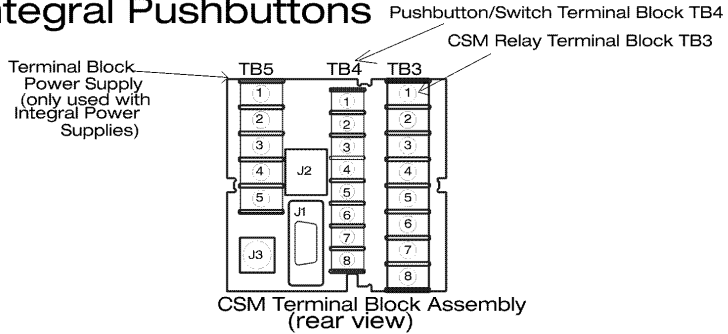

CSM WIRING

Common Service Relay Wiring

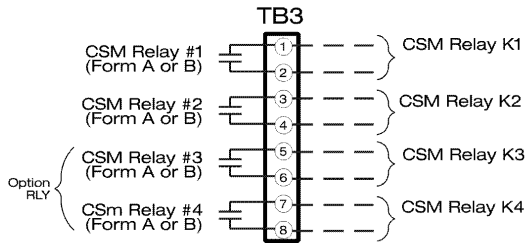

Pushbutton / Switch Wiring

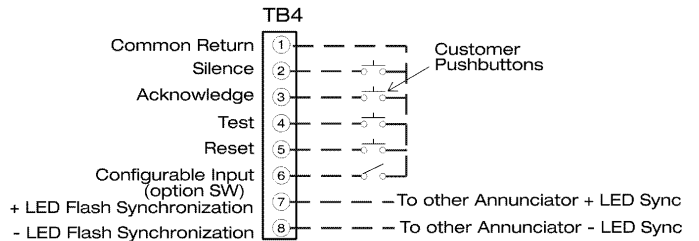

Note: TB4-7 can be used as a second Configurable Input when the LED Flash Synchronization Option is not used.

Power Supply Wiring

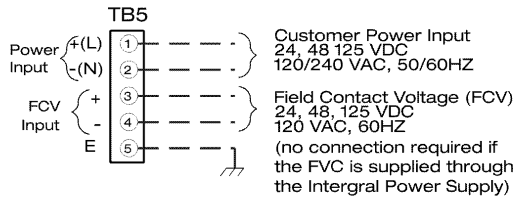

Communications Wiring

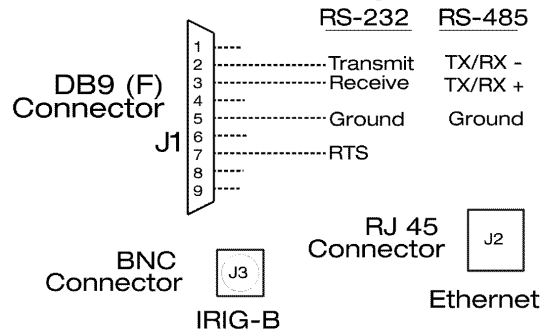

NOTE: When wiring an external horn or other audible device to the CSM output relays, it is recommended that the interconnect wires be physically isolated from any other input or output wiring.

Common Service Wiring (with I/O Modules)

Option Code NPB and LPPB

Model Code
NPB

FULL SIZE WINDOW

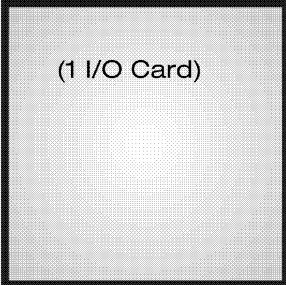

HALF SIZE WINDOWS

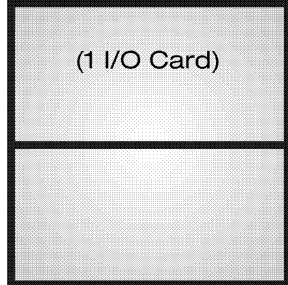

OR

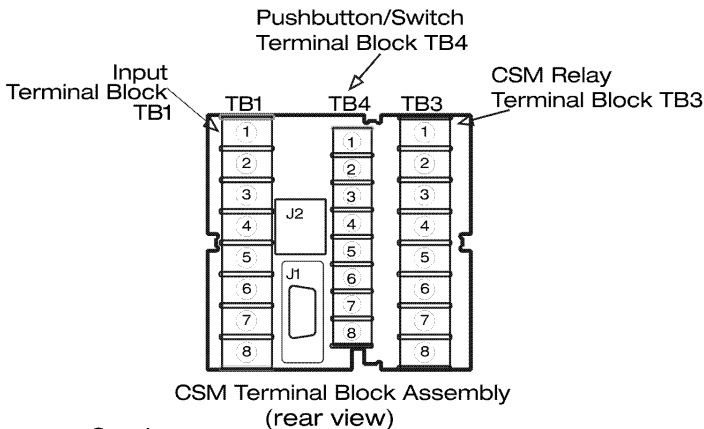

Common Service Relay Wiring

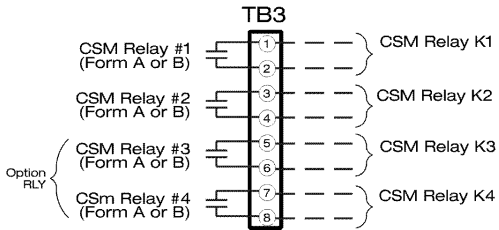

Pushbutton / Switch Wiring

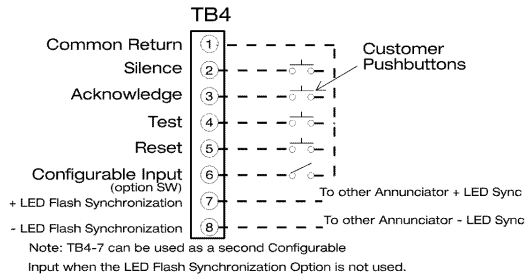

Input / Relay Wiring

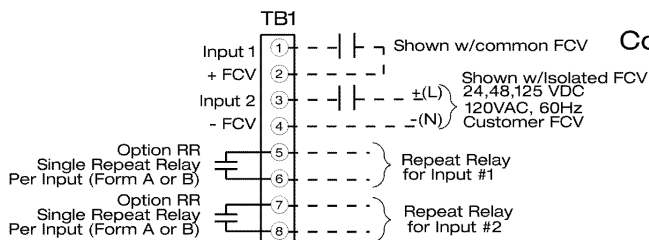

Communications Wiring

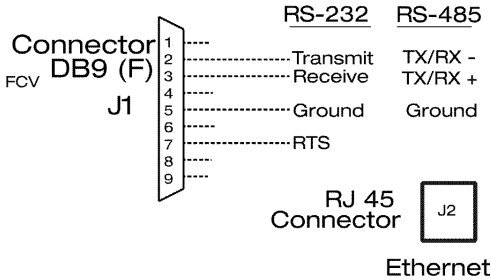

NOTE: When wiring an external horn or other audible device to the CSM output relays, it is recommended that the interconnect wires be physically isolated from any other input or output wiring.

CONNECTING POWER

The AN-3200 Annunciator operates from a selection of AC and DC Voltages. The Annunciator uses Power Supplies to provide the necessary 5VDC Logic and LED Power. If the Field Contact Voltage (FCV) needs to be provided from the Annunciator, separate FCV Supplies are provided.

For 24 and 48 VDC Input Power, an Integral Power Supply will always be used. In some cases, multiple supplies will be located in the system to accommodate the quantity of inputs specified.

For 120/230 VAC and 125 VDC Input Power, the quantity of inputs, window sizes and other options determines whether the Power supplies can be self contained within the Annunciator (Integral Power Supply) or external to the Annunciator. External power supplies shall be Class 2.

120/230 VAC & 125VDC Input Power

Annunciator Window Size	Integral Power Supply		External Power Supply	
	# of Inputs (with Repeat Relay option)	# of Inputs (without Repeat Relay option)	# of Inputs (with Repeat Relay option)	# of Inputs (without Repeat Relay option)
Full (1 per Cell)	1-25	1-30	>25	>30
Half (2 per Cell)	1-43	1-60	>43	>60
Third (3 per Cell)	1-56	1-90	>56	>90
Quad (4 per Cell)	1-60	1-100	>60	>100

The Field Contact Voltage (FCV) can be provided externally by the user or can be provided by the Field Contact Voltage Supply.

Field Contact Voltage

Customer Input Power	Customer Supplied 12, 24, 48, 125VDC	Annunciator Supplied Field Contact Voltage	
		24 VDC	125 VDC
24 VDC	X	X	X
48 VDC	X		
125 VDC	X	X	X
120 / 230 VAC	X	X	X

POWER REQUIREMENTS

External AC supply:

(Watts @ Annunciator power input per point)

Annunciator Window Size	I/O Cards with Repeat Relays	I/O Cards with no Repeat Relays
Full (1 per Cell)	1.7	1.4
Half (2 per Cell)	1.0	0.7
Third (3 per Cell)	0.7	0.4
Quad (4 per Cell)	0.7	0.4

Field Contact Voltage (FCV): 1.8 mA / point (nominal)

Integral AC supply:

(Watts @ Annunciator power input per point)

Annunciator Window Size	I/O Cards with Repeat Relays	I/O Cards with no Repeat Relays
Full (1 per Cell)	2.2	1.8
Half (2 per Cell)	1.3	0.8
Third (3 per Cell)	1.0	0.5
Quad (4 per Cell)	0.9	0.5

Field Contact Voltage (FCV): 1.8 mA / point (nominal)

Integral Power Supply

The Integral Power Supply is installed in slot 5 of the I/O or CSM Cell depending on the configuration and input power required. The Integral Power Supply provides a 5VDC output used for the Annunciator Logic and LED's. There are three different types of Integral Power Supplies available:

24VDC

48VDC

Universal 125VDC/120/230VAC.

Integral Power Supply Cell Locations

Customer Input Power	CSM Cell with Integral Pushbuttons	CSM Cell with one I/O Module	I/O Cell with one I/O Module	I/O Cell with two I/O Modules
24 VDC	X	X	X	X
48 VDC	X	X	X	X
125 VDC or 120/230 VAC	X		X	

Based on the size of the system, there could be several integral power supplies within the Annunciator. The location of integral power supplies within the Annunciator can be noted by the five position terminal block, TB5.

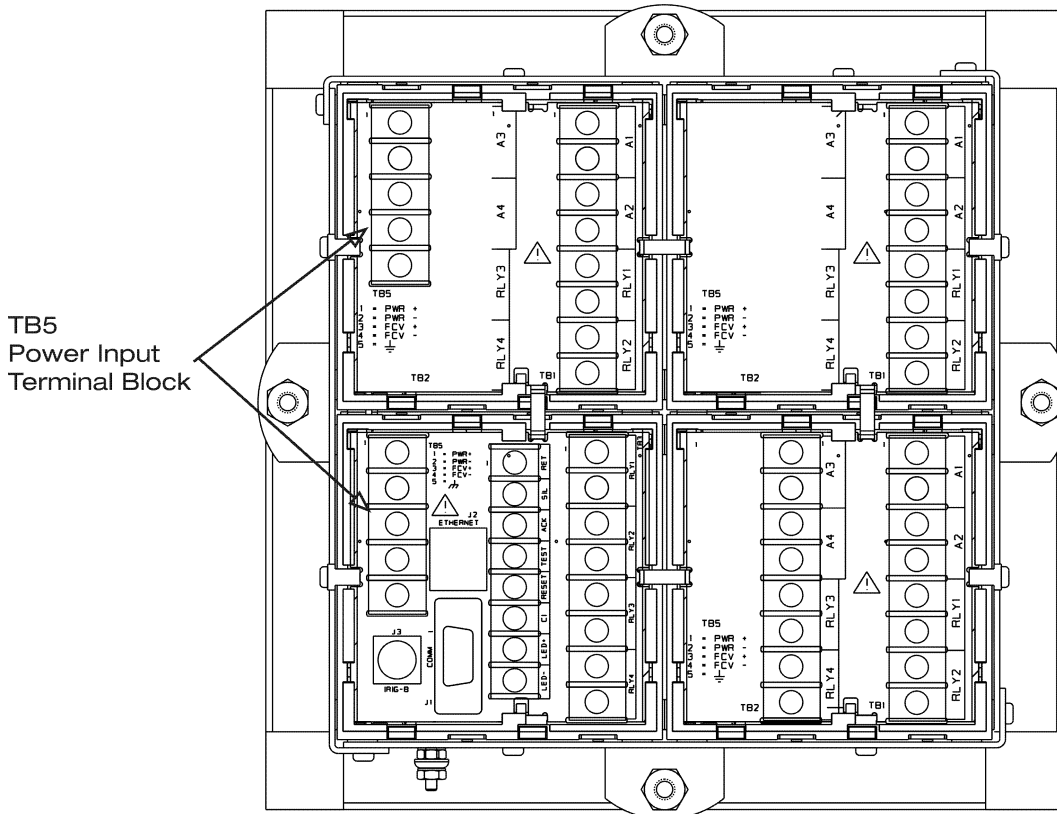

125VDC or 120/230 VAC Integral Power Supply

This universal integral power supply will accept either AC or DC inputs (not simultaneously) and provides a 5VDC output.

Quantity of Inputs per Integral Power Supply

Annunciator Window Size	I/O Cards with Repeat Relays	I/O Cards with no Repeat Relays
Full (1 per Cell)	25	30
Half (2 per Cell)	43	60
Third (3 per Cell)	56	90
Quad (4 per Cell)	60	100

Systems that exceed these quantities shall use an External Power Supply.

125VDC or 120/230VAC Integral Power Supply

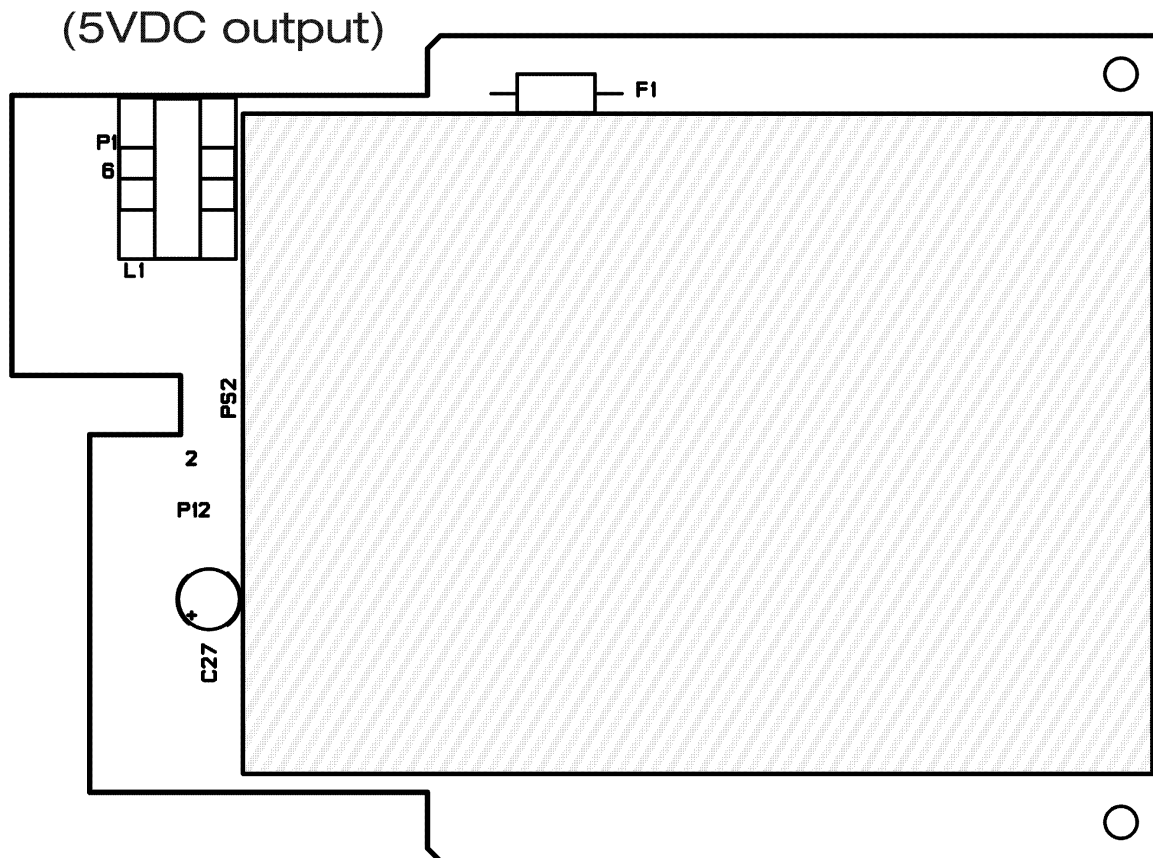

125VDC or 120/230VAC Integral Field Contact Voltage (FCV) Supply

The Integral FCV Supply is installed in slot 5 of the I/O Cell. This FCV supply will allow either AC or DC inputs (not simultaneously) and provides a 24VDC or 125VDC output.

Quantity of Inputs per FCV Supply

Field Contact Voltage	Number of Inputs
24 VDC	250
125 VDC	52

Systems that exceed these quantities shall use an External Power Supply.

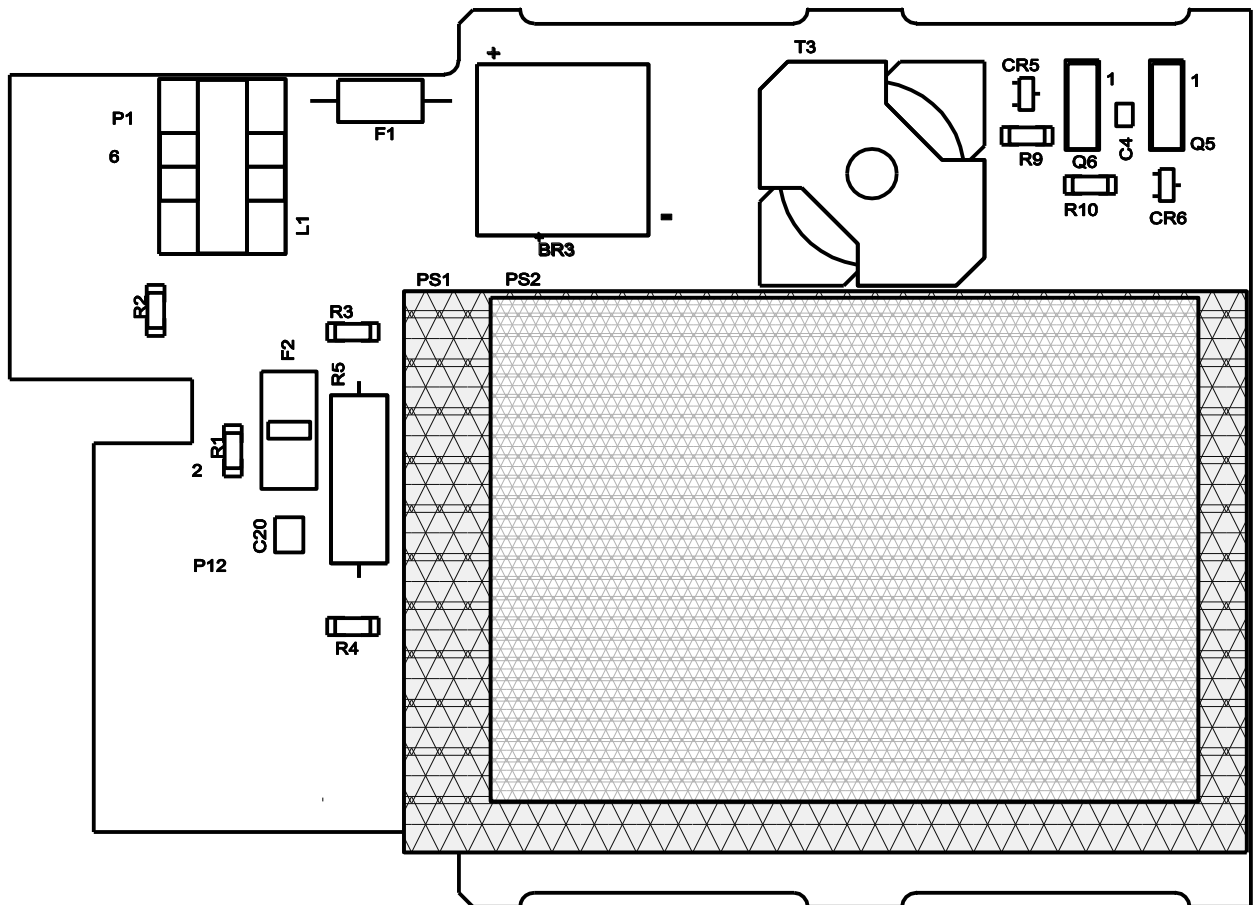

120/230 VAC and 125 VDC Integral Power Supply Wiring

Cell Variations for Power Supply Terminal Blocks (TB5)

I/O Terminal Ass'y

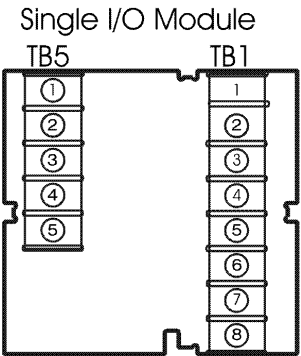

(Rear View)

I/O Terminal Ass'y

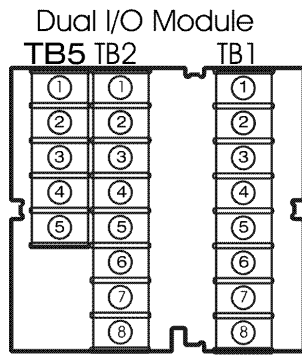

(Rear View)

CSM Terminal Ass'y

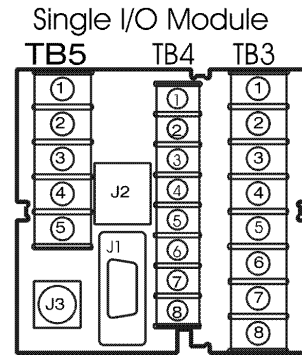

(Rear View)

125VDC Power External 125VDC FCV

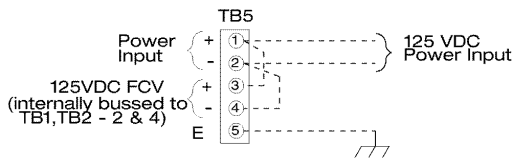

125VDC Power External 24 or 48VDC FCV

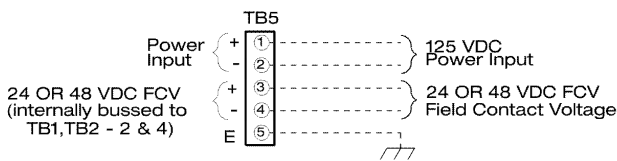

120/240 VAC Power External 24, 48, 125VDC FCV

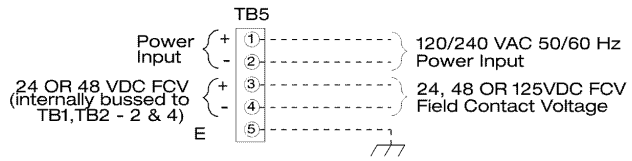

125VDC Power Internal 24V or 48VDC FCV

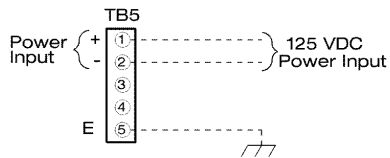

120/240 VAC Power Internal 24, or 125 DC FCV

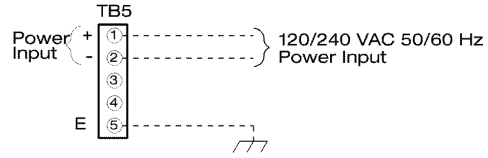

125VDC Integral FCV Supply

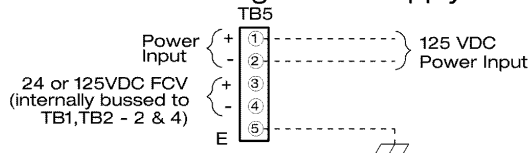

120/240VAC Integral FCV Supply

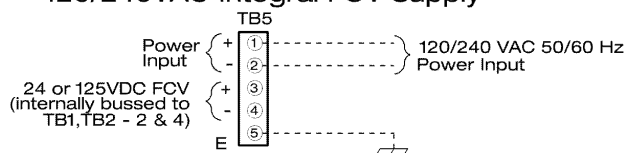

24VDC Integral Power / FCV Supply

This integral power supply is used for 24VDC Power Inputs or whenever external AC/DC power supplies are provided. The 24VDC input is converted to a 5VDC output. An FCV Supply can be added to this integral power supply for systems requiring 125VDC FCV.

Quantity of Inputs per Integral Power Supply

Annunciator Window Size	I/O Cards with Repeat Relays	I/O Cards with no Repeat Relays
Full (1 per Cell)	22	26
Half (2 per Cell)	37	52
Third (3 per Cell)	49	78
Quad (4 per Cell)	52	87

Quantity of Inputs per FCV Supply

Field Contact Voltage	Number of Inputs
125 VDC	52

Systems that exceed these quantities can use multiple integral FCV Supplies.

24VDC Integral Power Supply

(5VDC Output)

Shown with 125VDC FCV Supply

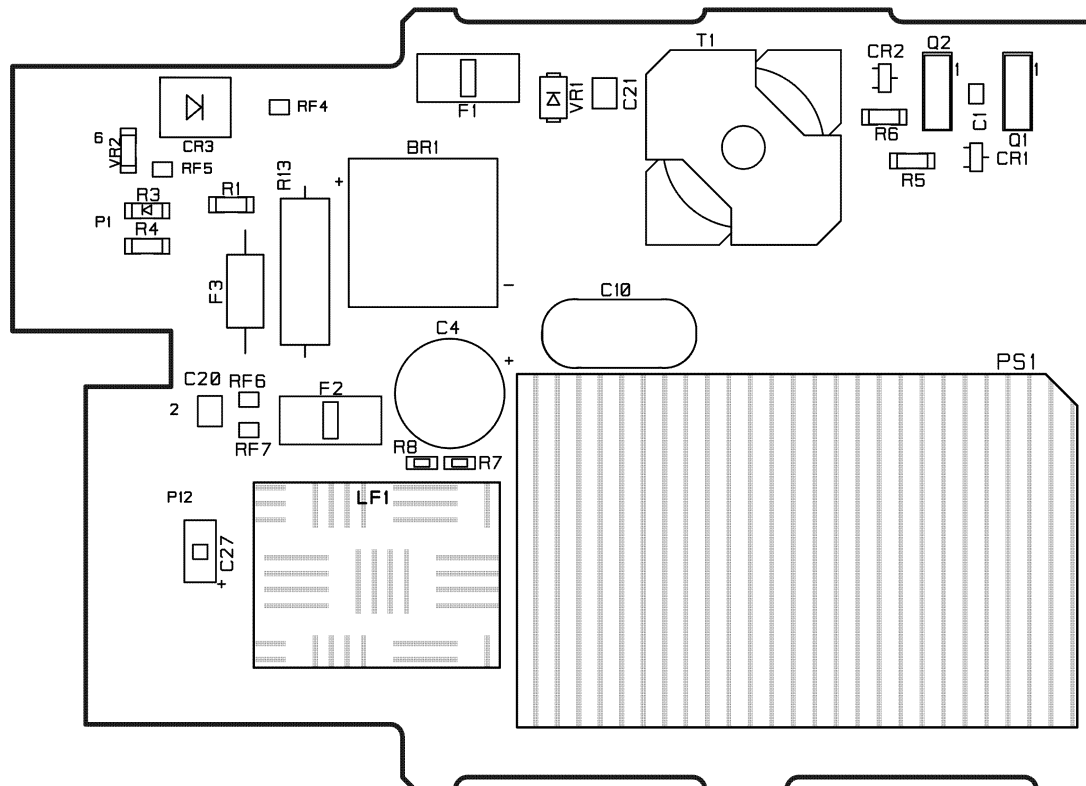

48VDC Integral Power Supply

This integral power supply is used for 48VDC Power Inputs. The 48VDC input is converted to a 5VDC output.

Quantity of Inputs per Integral Power Supply

Annunciator Window Size	I/O Cards with Repeat Relays	I/O Cards with no Repeat Relays
Full (1 per Cell)	22	26
Half (2 per Cell)	37	52
Third (3 per Cell)	49	78
Quad (4 per Cell)	52	87

48VDC Integral Power Supply
(5VDC Output)
Shown for external FCV

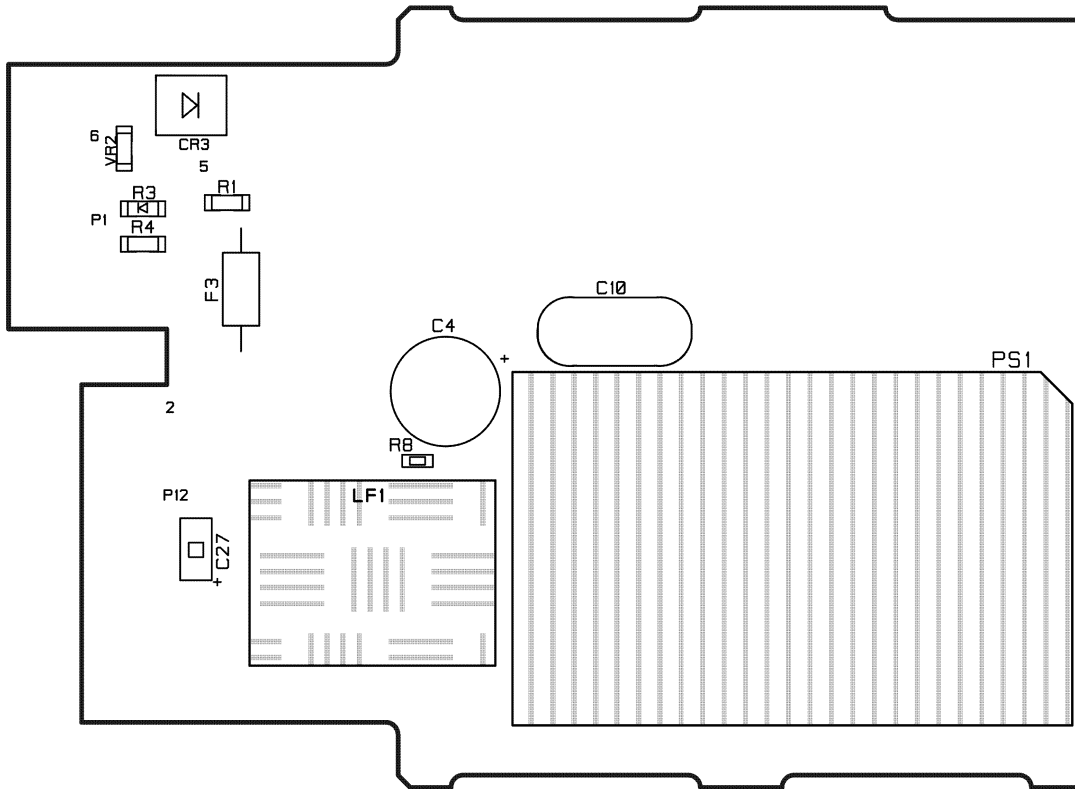

Note: In order to maintain a UL listing or CE Certification, any customer power supply used to provide 24VDC or 48VDC to the Annunciator shall be UL recognized or CE Certified, and provide basic insulation.

24 and 48 VDC Integral Power Supply Wiring

Cell Variations for Power Supply Terminal Blocks (TB5)

I/O Terminal Ass'y

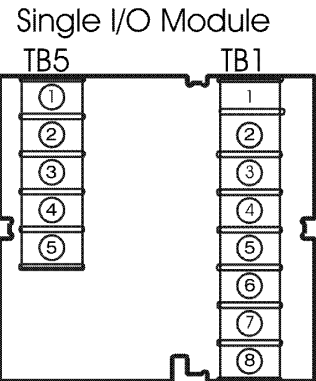

(Rear View)

I/O Terminal Ass'y

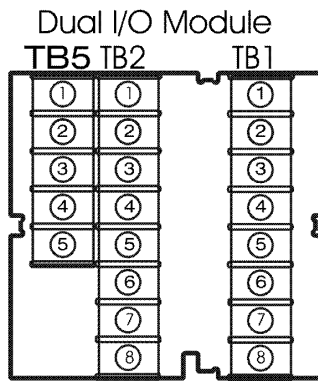

(Rear View)

CSM Terminal Ass'y

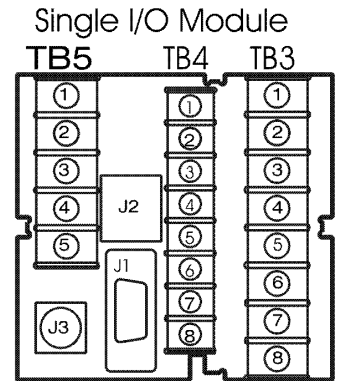

(Rear View)

24VDC Power
External 24VDC FCV

Integral Power Supply

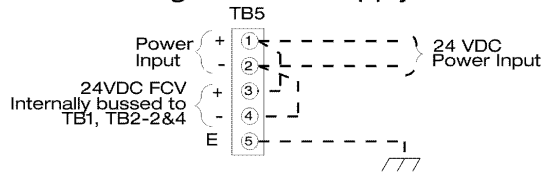

48VDC Power
External 48VDC FCV

Integral Power Supply

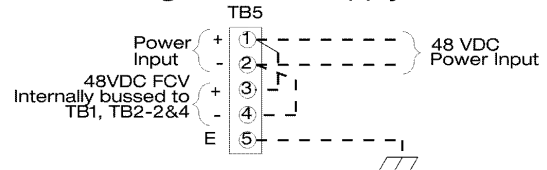

24VDC Power
Internal 125VDC FCV

Integral Power Supply

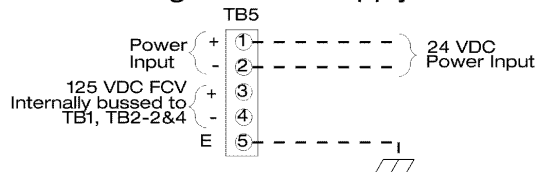

48VDC Power
External 24 or 125VDC FCV

Integral Power Supply

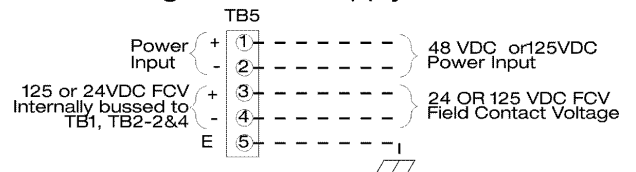

24VDC Power
External 48 or 125 VDC FCV

Integral Power Supply

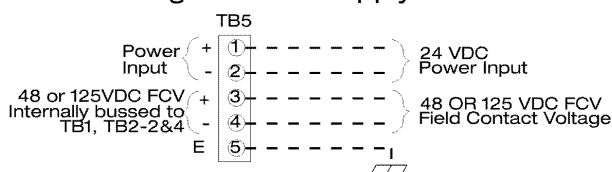

External Power Supply

For larger systems, an external power supply can be used for 120/230 VAC or 125VDC Input Power. In either case, the external power supply has a 24VDC output used to connect to the Integral 24VDC Supply. The quantity of Integral 24VDC Supplies required is shown in the chart below.

Quantity of Inputs for External Power Supplies

Annunciator Window Size	(1) AC or DC External Power Supply		(2) AC or DC External Power Supplies	
	(2) Integral 24VDC Supplies		(3) Integral 24VDC Supplies	
	# of Inputs (with Repeat Relay option)	# of Inputs (without Repeat Relay option)	# of Inputs (with Repeat Relay option)	# of Inputs (without Repeat Relay option)
Full (1 per Cell)	43	52	65	78
Half (2 per Cell)	74	104	111	156
Third (3 per Cell)	98	157	147	235
Quad (4 per Cell)	104	173	156	260

Annunciator Window Size	(2) AC or DC External Power Supplies		(3) AC or DC External Power Supplies	
	(4) Integral 24VDC Supplies		(5) Integral 24VDC Supplies	
	# of Inputs (with Repeat Relay option)	# of Inputs (without Repeat Relay option)	# of Inputs (with Repeat Relay option)	# of Inputs (without Repeat Relay option)
Full (1 per Cell)	87	104	108	130
Half (2 per Cell)	149	208	186	260
Third (3 per Cell)	195	313	244	392
Quad (4 per Cell)	208	347	260	433

For Field Contact Voltage, 24VDC can be derived from the External Power Supply 24VDC Output. For 125VDC, the Integral 24VDC Supply will be used.

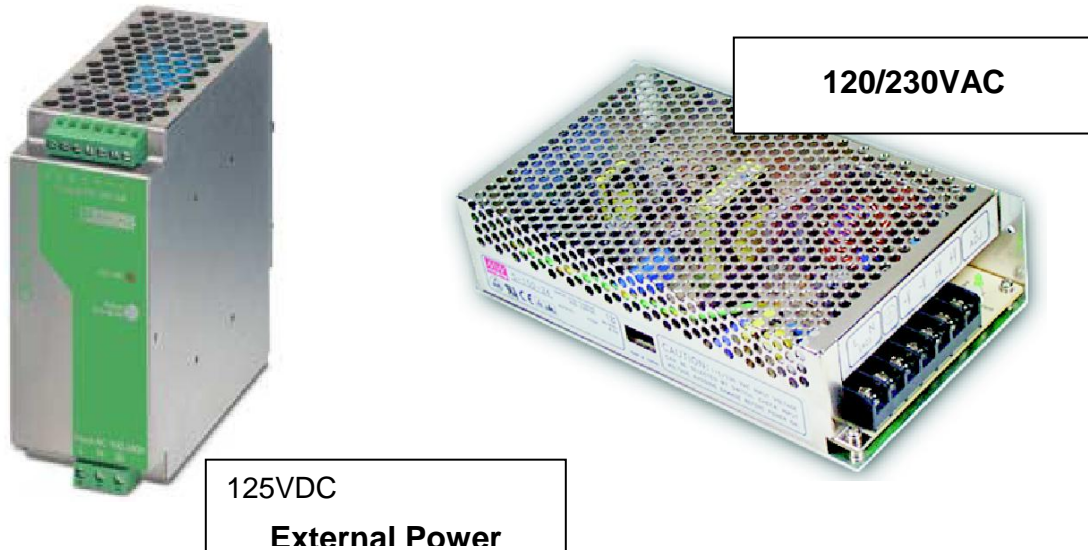

125 VDC External Power Supply Wiring

Internal 24 or 125VDC FCV
 24 VDC
 Integral
 Power Supplies

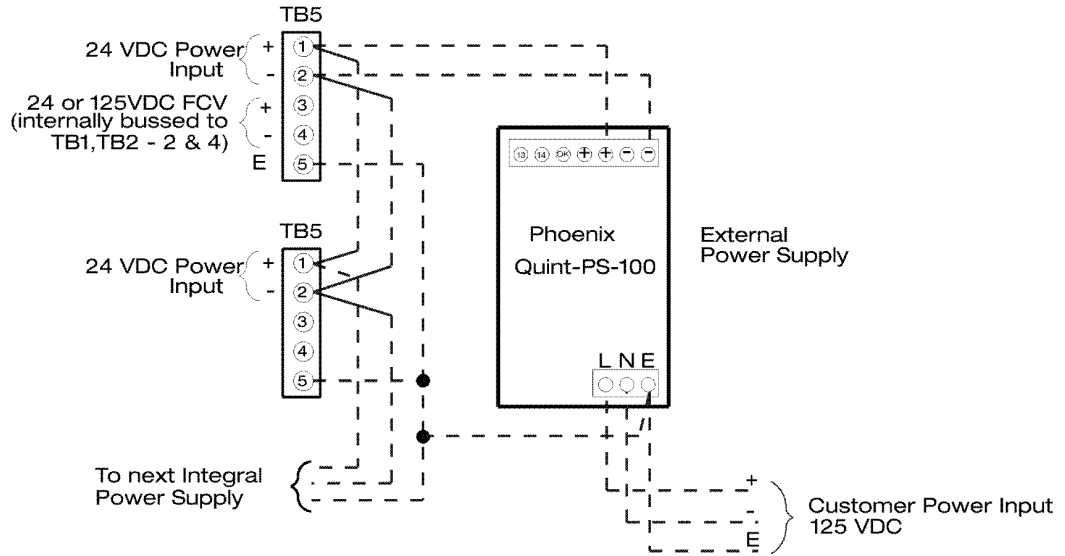

External 24,48,125VDC FCV

24 VDC
 Integral
 Power Supplies

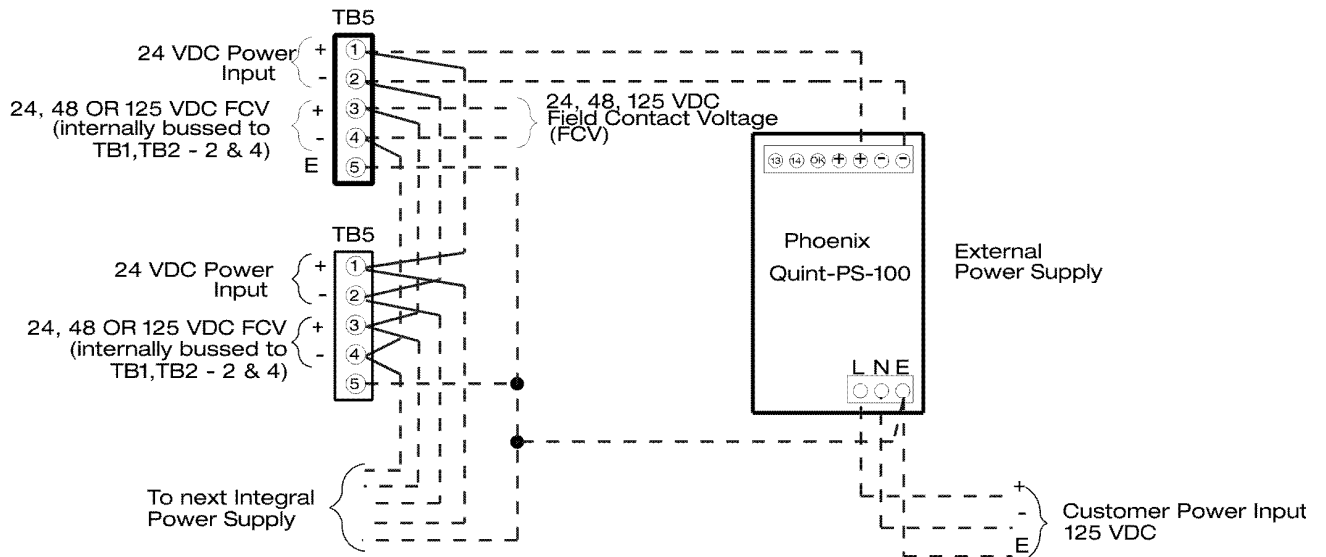

120/230 VAC External Power Supply Wiring

Internal 24 or 125VDC FCV

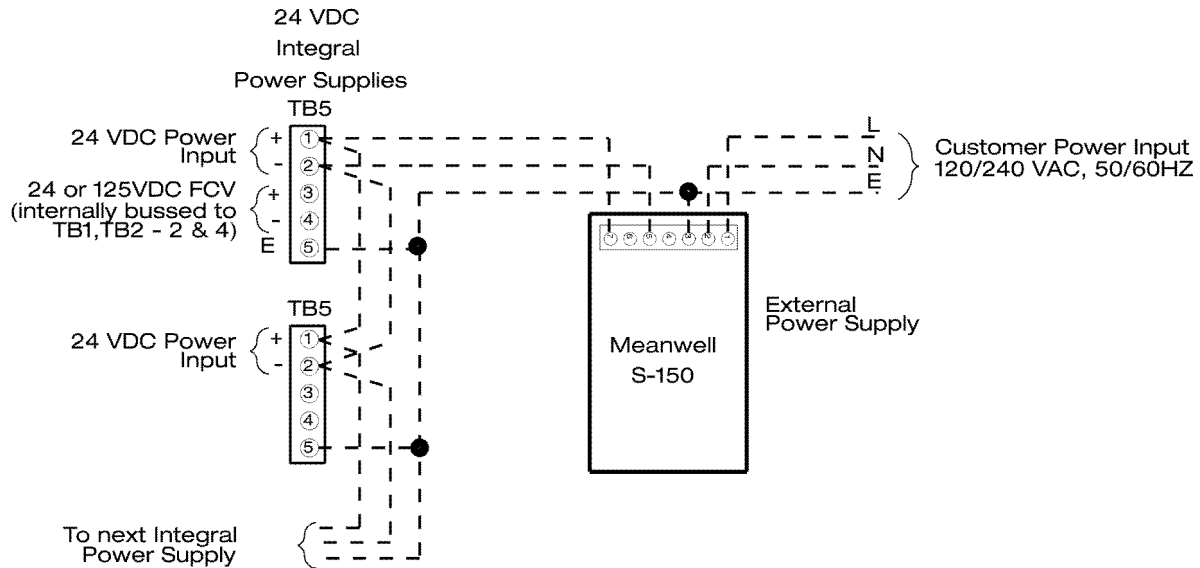

External 24,48,125VDC FCV

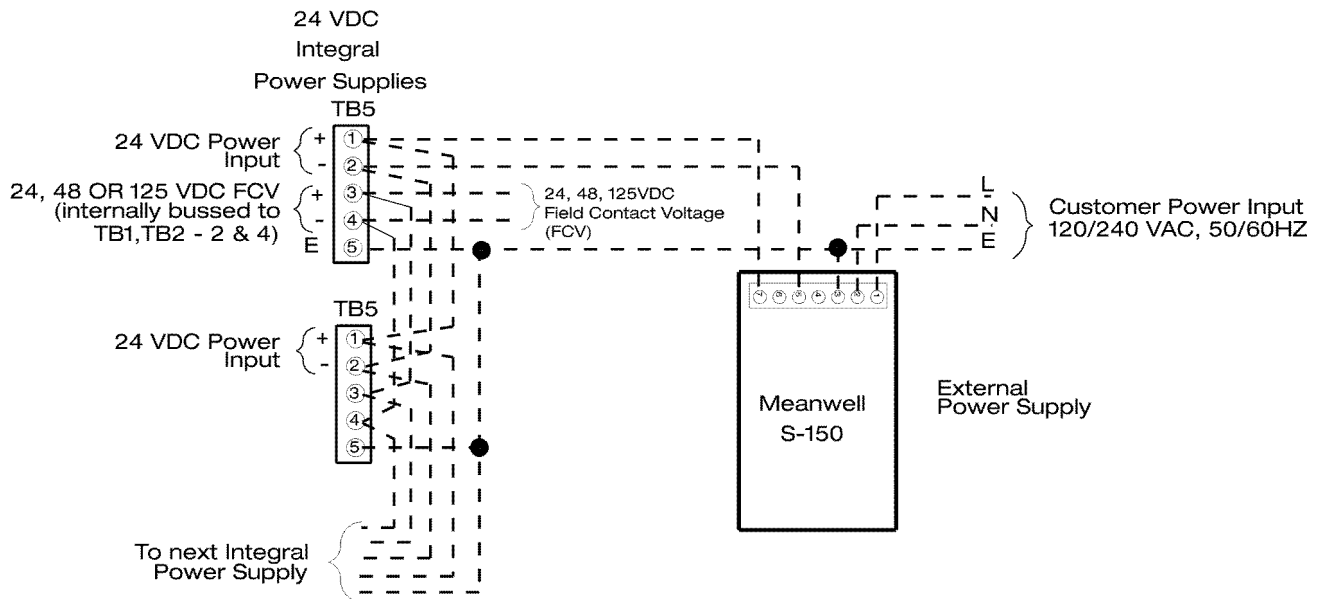

SOFTWARE CONFIGURATION

APPLICATION

The AN-3200 Annunciator Configuration application is used to create, edit and download annunciator configurations from a PC. The PC Comm Port connects directly to the annunciator via a serial port on the front of the CSM module.

A configuration may be created on the PC without a connection to the annunciator and then downloaded later. The configuration information is held as a file on the PC, which may be edited if a change is required. An exception to this is the physical size of the annunciator, which includes the number of input modules, and the size of each module, which is factory configured.

If a configuration is edited, checks are made to ensure that the correct file is downloaded to the annunciator. If more than one version of the AN-3200 configuration software is used then more than one version of the configuration file can exist. It is up to the user to ensure that copies of the configuration are kept up to date. If the application detects that the local and remote copies of a configuration are different the user can update either.

The application also includes a function to enable the configurable options in the annunciator, such as Modbus and DNP communications.

SOFTWARE INSTALLATION

The AN-3200 configuration software should be installed onto a PC with the following minimum configuration: -

300MHz Pentium II CPU

Windows 98/2000/XP

64Mbytes RAM

20Gbytes hard disk

Insert the AMETEK AN-3200 Configuration CD in the CD-ROM drive. This will automatically start the installation process. If this does not happen choose 'Run' from the 'Start' menu then browse to the CD-ROM drive and click on '*Autorun.exe*'.

During the installation, you will be prompted to select the type of Annunciator you wish to configure. Select only the models you wish to use to avoid confusion with extra choices.

SOFTWARE CONFIGURATION INSTRUCTIONS

This is an overview of the configuration steps required for editing or creating an Annunciator configuration. Refer to the next section for additional detail on the menu selections.

Reviewing or editing the Factory Configuration

All Annunciators are factory configured per the model number. Some of these selections, such as Alarm Sequence can be changed with the configuration software. Other features not in the model number, such as N.O./N.C. Inputs, Input Delay, CSM Relay Outputs can also be edited.

1. Remove the front mounted pushbuttons in the CSM Cell (or windows used in the lower right Cell) to gain access to the CSM front mounted Serial Port. Connect the serial (one to one) cable provided with the Annunciator between the AN-3200 CSM Port and the PC with the Configuration Software installed. (**Note:** The serial port on the rear of the Annunciator is used for the optional communications; Modbus, DNP, etc. It is NOT used for the system configuration.).
2. Start up Configuration Software. If a default configuration appears, press Cancel.
3. Select Connections, then Settings and configure your PC Serial port for the Com Port where your serial cable is plugged into, 9600 Baud, no parity and address 1
4. Select Connections, and then Connect. If successful, the Annunciator lights will flash fast and a pop up screen will appear with your serial number. Press OK.
5. If you see a screen that says 'Configuration Mismatch', select Download Configuration from the Annunciator.
6. If you see a screen that says 'This is not the correct configuration file type for this Annunciator', Select File, and Open up a known configuration file for this type of Annunciator. If a file is not available, follow the instructions below for creating a new configuration.
7. Start the configuration software and select File, New. Select the correct type of Annunciator if prompted. Select Cancel in the configuration menu. Select Connections, and then Connect. You may be prompted to configure certain options not present in your configuration; select NO. Cancel out of any configuration menus. Select Connections, Configuration, Read Configuration. When done, you can Select File, Start Wizard and this will show how the Annunciator is currently configured.
8. Select File, Start Wizard and this will show how the Annunciator is currently configured. You can make changes to any of the selections. For more detail on any of the selection, refer to the next section on the Configuration Wizard.

9. When finished making any changes, select save and enter the file name if prompted. Select Connections, Configuration, Write Configuration. When it is complete, select Connection, Disconnect. Press the TEST pushbutton to verify that everything is functioning correctly.

Creating a new Configuration

New configurations may be created both on-line (connected to an Annunciator) or off-line.

1. Start the configuration software and select File, New. Select the correct type of Annunciator if prompted.
2. The Annunciator Configuration Wizard will start up allowing you to make all configuration selections.
Note: When creating a new configuration, make sure you select the correct System Size (rows high x columns wide) and Window Size (1, 2, 3, 4 windows per cell), otherwise, it can disrupt all settings.
3. Select all configuration choices desired (reference the next section for a complete description of choices). When done, save the file.
Note: Some options, such as Modbus, DNP, and CSM Relays will not be shown in the 'New' file configuration. Once you connect to the Annunciator, it will indicate which options are available.
4. If off-line during the configuration, you can connect the PC to the Annunciator and download the configuration. (Select Connections, Configuration, Write Configuration.)
5. After you connect to the Annunciator, you may be prompted to configure certain options not present in your configuration. You can configure these options if desired and then save the file when done. Select Connections, Configuration, Write Configuration. When it is complete, select Connection, Disconnect. Press the TEST pushbutton to verify that everything is functioning correctly.

SOFTWARE CONFIGURATION MENUS

Main menu overview

The main application window comprises of five main menus, File, Options, View, Connections and Help. These appear at the top of the screen above the application toolbar, which provides quick access to the main functions of the program.

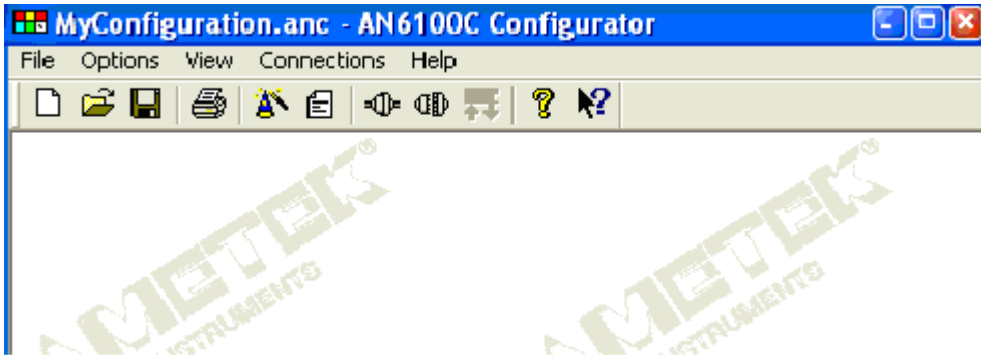

File Menu

The program manages configuration files through the File Menu. From this menu, you can open, save, and delete configuration files. The File Menu also provides you access to a new "default" configuration as a point of reference.

Options Menu

This menu provides functionality to alter the way your program behaves and appears.

View Menu

Here you can select what you see in main window. Status bar, Tool bar etc.

Connections Menu

Connections menu performs the actual communication with the annunciator to download or retrieve configurations.

Help Menu

The Annunciator Configuration is equipped with a Help Menu to provide the user with assistance for each screen and program function.

File

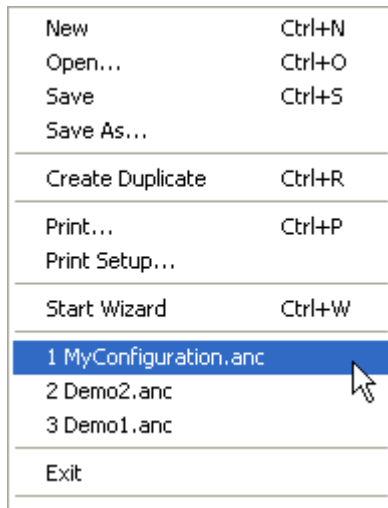

In the File menu you will find the following menu options:

New

Clicking on this will create and open a new configuration. As only one configuration can be open at a time, any previous configuration that is open will be closed. You will be prompted to save any changes before the configuration is closed. New configurations are set to the defaults.

Open

Here you can browse available locations on your system to open existing configuration files. (file extension ".anc").

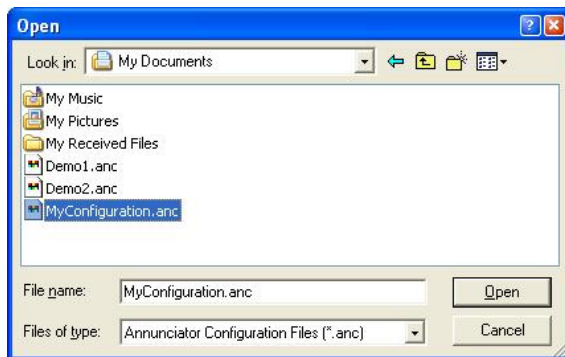

Save

Allows you to save the active configuration file. If the configuration file has already been saved, it will automatically write over the old version.

Save As

Allows you to save the active configuration file. When clicked, it will ask you for a filename before proceeding. If the filename already exists, it will ask you if

you want to overwrite the old version.

Create Duplicate

This will create and open a new configuration file; the parameters will be copied from the active (open) configuration and not set to defaults. This allows the same configuration settings to be downloaded to two annunciators.

Print

This allows you to print the configuration in a text form so that you can see all the parameters. The printout is marked with the time and date of printing.

Print Setup

This allows you to change your printer settings.

Start Wizard

This will start the configuration wizard, which will guide you through a set of screens to simply setup your annunciator.

Recent Files

At the bottom of the file menu, you will also find a list of you most recent configuration files. You can simply click on one of these to open it.

Options

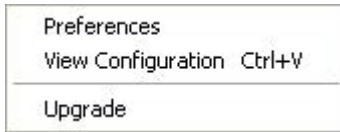

Preferences

In the preferences menu you can change the color setup of the whole application, and tell the program how you want the wizard to behave.

View Configuration

This is a textual overview of the complete configuration.

Upgrade

This menu option will allow you to add extra functionality to your annunciator and the configurator.

Preferences



Colors

The colors used to indicate various selections used in the configuration software may be changed. This may be required if they conflict with colors used in the Windows desktop. For most installations the default colors will be acceptable.

To change a color first select its usage from the list then click on 'Change Color' and select the new choice from the palate.

General

If the box beside "Start wizard when opening file" is checked, the wizard will automatically appear every time a new or existing document is opened. As the last open configuration is loaded when the application starts it means that the wizard will also automatically start at this point.



View Configuration (Text)

This allows you to see the complete configuration as text. Once this dialog is shown there are a number of options available.

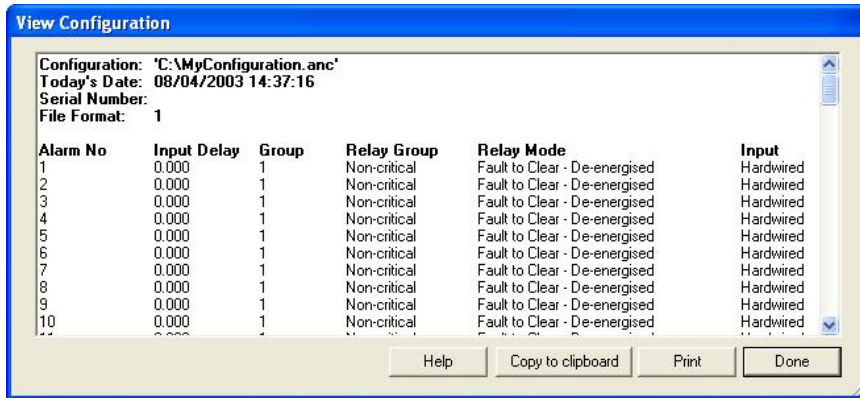

Copy to clipboard

You can use the mouse to select a portion of the configuration and then copy the selection to the clipboard so you can paste it into other documents. If you do not select any text the whole configuration is then copied.

Print

This will print the complete configuration.

Upgrade

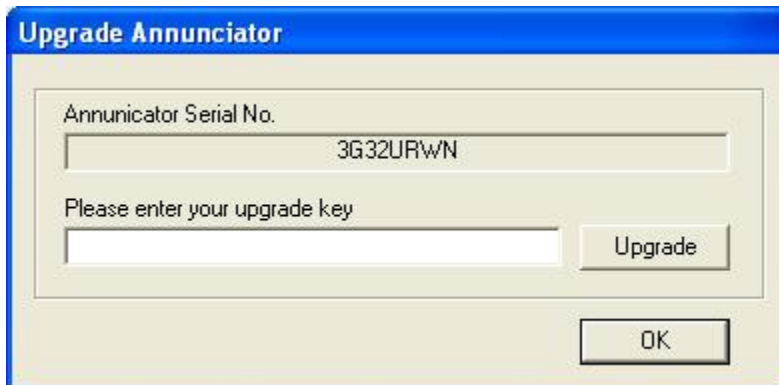

The application also includes a function to enable the configurable options in the annunciator. One such is Modbus communications.

To enable any of these options you must contact AMETEK Power Instruments with your annunciator serial number that you will find in the Upgrade dialog. You will be given a unique key, which you must type into the box (shown above) and then click upgrade.

If you are connected to an annunciator the upgrade will be performed right away. If you are not connected then you must save the configuration and upload it at a later date.

Note:

To successfully obtain the serial number of the annunciator you must have uploaded the configuration at least once. If the configuration has never been uploaded to an annunciator you will get the following message where your serial ID should be.

"This configuration has not been uploaded to an annunciator."

Connections

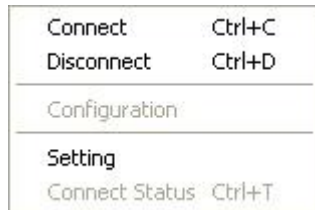

Connect & Disconnect

From the connections menu you will be able to connect to or disconnect from your annunciator using the *Connect* and *Disconnect* menu options.

Configuration

Once you have successfully connected to your annunciator you will be able to select the *Configuration* menu option. This will allow you to read and write configurations to and from the annunciator.

Settings

Here you change your computer's settings to tell it how to connect to your annunciator.

N.B. The annunciator functions will not operate while the configurator is connected to the AN-3200.

Configuration

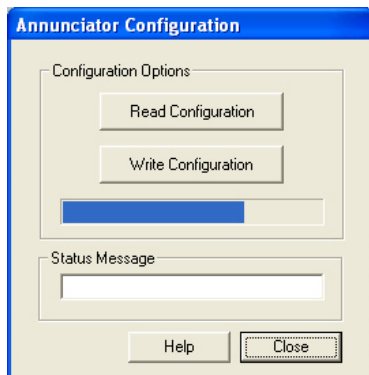

Read Configuration

This copies the configuration from the annunciator into the active configuration. It is recommended that you save any configuration changes before reading a configuration. If you wish to discard your changes you can open another document or close the application opting not to save.

Write Configuration

This will copy the active configuration to the annunciator. It is recommended that you save any configuration changes before writing to the annunciator.

Note:

When a configuration is written to an annunciator the file is, from then on associated with that specific annunciator. As a result of this association, on subsequent sessions there are certain configuration options, which will be disabled. They are listed below.

System Name

Number of rows

Number of columns

Alarms per module

Number of hardwired inputs

Input delay resolution

They can only be changed when creating a New Configuration.

Note: Changing the system size or window style to something different than your actual Annunciator can cause problems.

Communication Settings

From this dialog you can select the Com port wish to use to connect and the baud rate and parity of the connection, and the *address* of the annunciator.

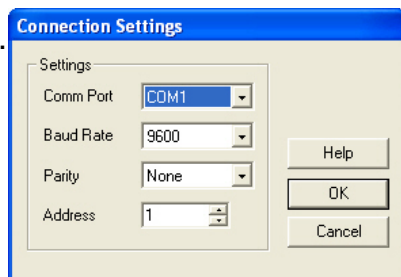

These values are stored independently of the annunciator hence care must be taken as if you have more than one annunciator they may not all have the same settings.

Connect Status

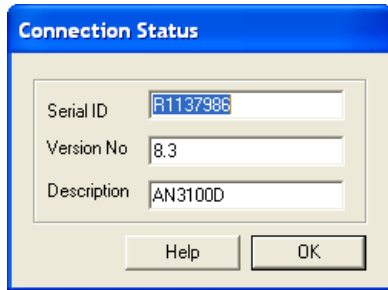

This option can be used when connected to retrieve the serial ID, the Hardware version and the system description. When nothing is connected the menu option is disabled. This can be used as an indicator to a successful connection.

Configuration Mismatch

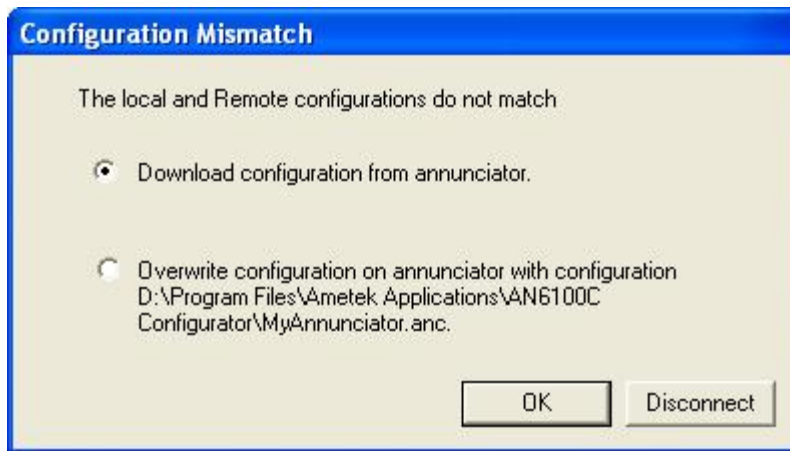

When you connect to an annunciator the program checks to see if the active file was the last configuration to be downloaded to the annunciator, if this is not the case then the message shown above will be displayed.

A Configuration mismatch may occur as a result of the following:

- 1) You have opened the wrong configuration file.
- 2) Someone else has downloaded a different configuration to the annunciator.

If you choose the first option "Download configuration from annunciator" this will copy the configuration from the annunciator in to the active file.

If you choose the second option "Overwrite configuration on annunciator with configuration....." this will copy the configuration in the active file to the annunciator.

In the case of a configuration mismatch it is recommended that you select the first option and then save this configuration to another location as a backup.

Serial ID Mismatch

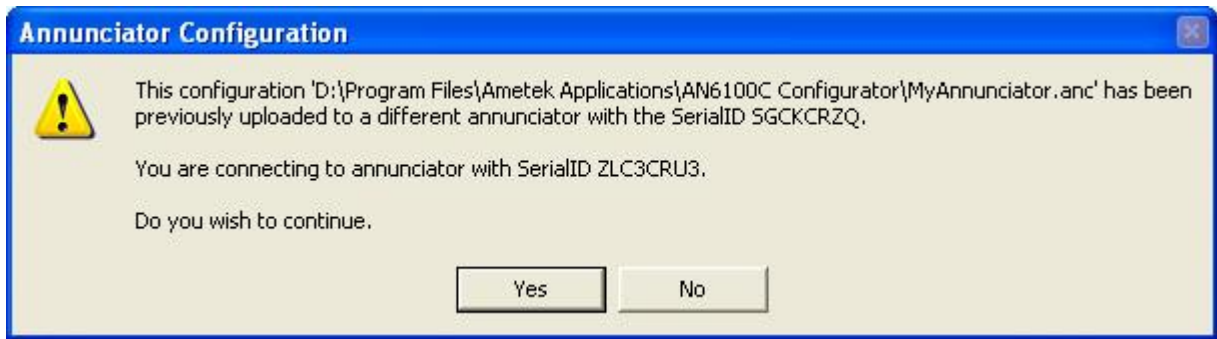

A serial ID mismatch occurs when you try to upload a configuration that has already been uploaded to another annunciator. When you upload a configuration, a note is kept of which annunciator it "belongs to". Every time you connect to an annunciator the stored serial ID is checked to make sure that it matches the annunciator you are connected to.

In the case of a serial ID mismatch if you hit continue you will be able to read the configuration from the annunciator but you will **not** be able to write the active one to the annunciator.

To rectify this situation you should click "No" and then open the correct configuration file, or create a new configuration.

Configuration Wizard

The configuration of an AN-3200 is defined in a number of sections, which are displayed on separate pages. The pages may be selected by clicking on the labeled tabs at the top of each page. When a system is configured for the first time the '*Next >>*' button may be used to move through all the sections. This will ensure that no sections are missed. The '<< *Back*' button may be used to go to the previous page if required.

A graphical representation of the annunciator is used to simplify the configuration. This mimic diagram may be given the same window colors as the actual unit to make correct input selection easy. Individual or groups of inputs or modules can be selected by clicking on them. (To select a group of inputs, select an input with the mouse and hold & drag across other cells. You can also use the Ctrl key to pick a group of inputs.)

The Configuration Wizard Screens and their functions are detailed below:

System: Used to configure System Size (High x Wide), Window size per cell and other system-wide features. Once configured and downloaded it will be locked to prevent any further changes.

Input Configuration: Used to select individual settings per input, such as input delays, repeat relay operation, critical/non-critical alarms, alarm sequence groups. These settings can be edited or changed at any time.

Lamp Configuration: Used to configure flash rates for slow, fast and intermittent speeds as determined by the operating sequence.

Sequence: Selection of the operating sequence for each alarm group.

CSM: Set-up of auxiliary relays and other system-wide functions.

Switch Input: Set up for optional external switch inputs and Test Pushbutton operation.

ASCII: ASCII set-up configuration. (Only shown when option is enabled.)

Modbus: Modbus set-up configuration. (Only shown when option is enabled.)

DNP: DNP set-up configuration. (Only shown when option is enabled.)

System

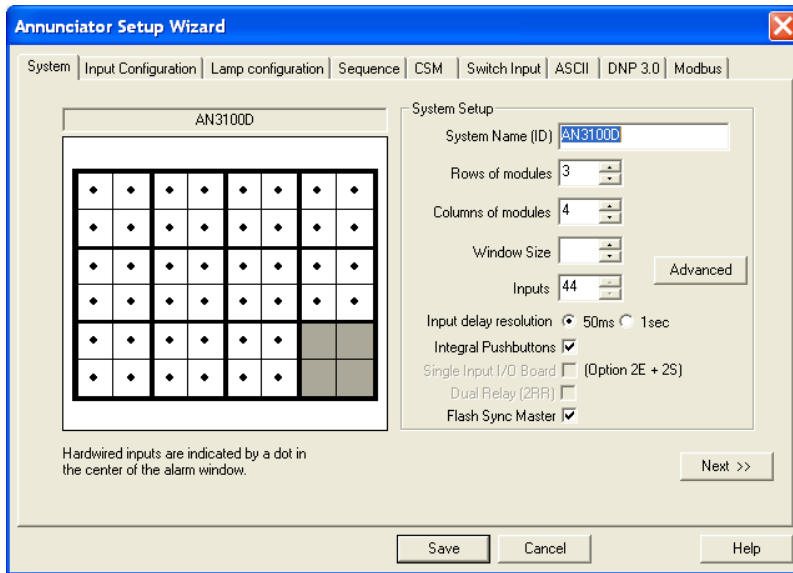

The hardware configuration is defined in this page. The values **must** match the actual size of the AN-3200. A mimic diagram of the annunciator is shown on the left hand side. The blank section on the bottom right of the annunciator is the Common Service Module (CSM).

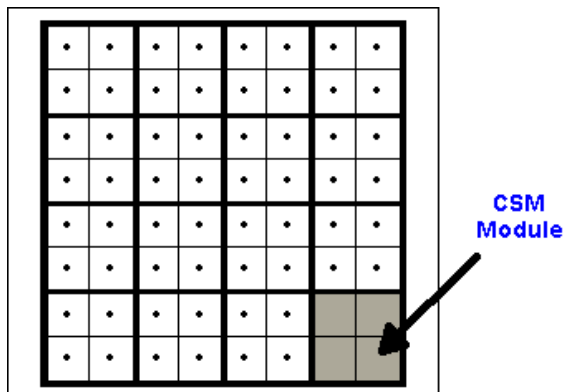

Note: After the configuration is uploaded to the annunciator for the first time the system parameters cannot be edited. The controls will be disabled. Care should be taken that the System values are correct. To make a change, you must create a new configuration.

System Name (ID)

This name is used to uniquely identify the annunciator. Up to 16 characters may be used.

Rows and Columns of Modules

Use the up or down arrows to the right of each value to set the actual number of modules. The AN3200 annunciators are limited to 13 rows or 13 columns and a maximum of 200 alarms or 50 Cells. (Example: a 13 x 4 system is not allowed, but a 5 x 10 is.)

Alarm points per module

There may be 1, 2 or 4 points per module as determined by your window size. Quad size windows use 4 points per cell, Triple Size windows use 3 per cell, Dual or Half Size windows use 2 per cell and Single or Full Size windows use 1 point per cell. By default all modules have the same number of points. If different numbers of points per module are required (Option IMW) click on the Advanced button.

Hardwired inputs

The default is that all inputs are hardwired, which refers to the field contacts wired to the back of the annunciator. On the mimic diagram the hardwired inputs are shown with a dot at the center. Non-hardwired inputs refers to inputs that are received via the serial communications. Non hard-wired inputs do not respond to the I/O cards or field contact inputs.

Note: Serial Communications may be used for both Hardwired and Non-Hardwired systems.

Input delay resolution

This determines the system-wide increment value for the input delay (or response) for each alarm. It is used in conjunction with the individual input delay setting in the Input Configuration Screen. The setting is based on whether your maximum input delay will be 12.5 seconds or 250 seconds. You have 255 increments of the value selected. For the 50ms setting, you can have a selectable software delay in 50 msec increments up to 12.5 seconds. For the 1sec setting, you have a selectable software delay in 1 second increments up to 250 seconds. Each input can have its own delay assigned as shown in the Input Configuration page, however, this system setting (50msec or 1 sec) is applied across the whole system.

Integral Push Buttons (Option INTB, NPB, LPPB)

These are the pushbuttons located in the lower right cell of the Annunciator System (Option INTB) or on the bezel (Option LPPB). They include Annunciator Functions: Test, Acknowledge, Silence and Reset. Option code NPB specifies no integral pushbuttons. When options NPB or LPPB are specified in the model number, the software box labeled Integral Pushbuttons should be unchecked, to allow up to two active alarm windows in this position. For all selections (INTB, LPPB or NPB), external pushbuttons can be connected to the Annunciator terminal blocks with the same functionality.

Single Input I/O board (Option 2S)

This is selected whenever window size option 2S (two point windows with single input per I/O board) is selected. The standard I/O board has two inputs available, but in certain configurations, as listed above, it is necessary to only activate a single input on this module.

Dual Relay (Option 2RR)

This will provide two repeat relay outputs (each selectable for Form A or Form B operation) for every input. This is only available whenever window size option 1 (single point windows) or 2S (two point windows with single input per I/O board) are selected.

Flash Synch Master (Option FS)

A software selection box is provided for flash synchronization between several different AN-3200 Annunciators. In systems that require flash synchronization, one Annunciator is configured as the Master (box checked) and all others are configured as the Slave (unchecked). Wiring between the Annunciators is required to share the flash signals. (Reference the Common Service Cell Wiring diagrams.)

In systems that don't require flash synchronization, the Flash Sync Master box must be checked. When setting up a system for flash synchronization, the flash lamp rates should be configured as follows: (reference the Lamp Configuration Screen)

Master and Slave Lamp Flash Rates should be identical except, on the Slave units, set the Slow Flash 'On' time approximately 0.1 sec lower than the Master. This ensures the slave unit is ready and waiting for the sync edge from the master.

Set the Slow and Fast rates in even multiples. (Example: Slow Flash = 1.0 sec, Fast Flash = 0.5 sec). Use of intermittent flash is not recommended.

Use alarm sequences that are either identical between master/slave units or ones that share the same flash rates (slow, fast, etc.)

Note: If a Slave unit does not receive the flash synchronization signal from the Master unit, the slow flash will become steady on.

Input Configuration

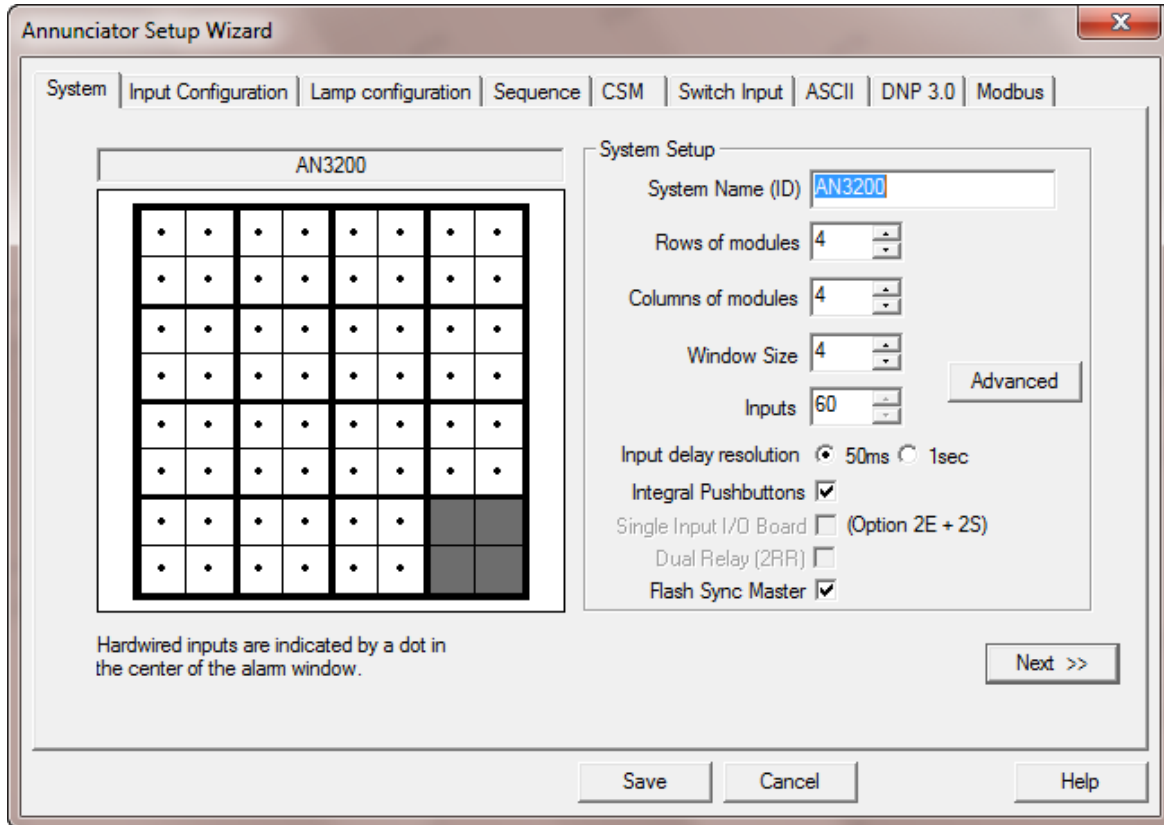

The configuration of each alarm input is defined in this page. To simplify this procedure a number of similar inputs may be selected at the same time and common parameters set.

An individual input is selected by clicking on it. The input will change color when selected. The input number will be shown in the 'Alarms' list. To select a number of inputs hold down the 'Ctrl' key while clicking on the inputs. To de-select an input press the 'Ctrl' key and click on the input again. To select a rectangular block of inputs click on the top left hand one then drag down to the bottom right.

When one or a number of inputs has been selected the parameters for those inputs may be set.

Alarm Numbering

The inputs are numbered left to right and top to bottom. The inputs within a module are numbered in sequence followed by the next module. So, for example, the top row of inputs of modules with four inputs each are:-

1, 2, 5, 6, 9, 10,

Alarm numbering...

1	2	5	6		
3	4	7	8		

Relay Mode (optional)

If the repeat relay option has been included with your system, you may select the Relay Mode for each input as follows:-

Follows Input Contact – Normally Energized

The repeat relay will follow the status of the field contact, regardless of the pushbuttons pressed. In this mode, the relay coil is energized in the normal (non-alarm) state.

Follows Input Contact – Normally De-Energized

The repeat relay will follow the status of the field contact, regardless of the pushbuttons pressed. In this mode, the relay coil is de-energized in the normal (non-alarm) state.

Latched Alarm till ACK – Normally Energized

The repeat relay will change state during an alarm and latch on until the acknowledge pushbutton is pressed, which returns the relay to the normal state. In this mode, the relay coil is energized in the normal (non-alarm) state.

Latched Alarm till ACK – Normally De-Energized

The repeat relay will change state during an alarm and latch on until the acknowledge pushbutton is pressed, which returns the relay to the normal state. In this mode, the relay coil is de-energized in the normal (non-alarm) state.

Latched Alarm till Reset – Normally Energized

The repeat relay will change state during an alarm and latch on until the reset pushbutton is pressed, which returns the relay to the normal state. In this mode, the relay coil is energized in the normal (non-alarm) state.

Latched Alarm till Reset – Normally De-Energized

The repeat relay will change state during an alarm and latch on until the reset pushbutton is pressed, which returns the relay to the normal state. In this mode, the relay coil is de-energized in the normal (non-alarm) state.

Follows Lamp Display – Normally De-Energized

The repeat relay will follow the state of the lamp display for that input. When the display is flashing on and off, it will toggle open and closed at the slow flash rate. When the lamp display is on steady, the repeat relay contact will be closed. It will open when the lamp turns off.

Note: In addition to these configurations, the repeat relay contact may be selected as a Form A or (Normally Open) or Form B (Normally Closed) using the I/O jumpers described in the previous section.

Alarm Group

Each input belongs to one of 4 groups. The groups define the alarm sequences that are set in the 'Group' page. This allows up to 4 first out groups per system or four different sequences.

Input delay

This is also referred to as the input response time, which is the amount of time an input must be in the alarm state before it is recognized as a valid alarm. Each input may be set from 1 second to 250 seconds in 1 second increments or from 50 msec to 12.5 seconds in 50 milliseconds increments. The system wide input delay resolution (50ms or 1sec) is set on the System page.

Systems with FR Option enabled (1 msec response) will have an additional software selection shown for 1 msec input.

Note: The Input Delay is the total delay including hardware and software filtering. For AC Inputs, there will be an additional 40 msec hardware filtering delay added to these numbers.

Critical alarm

Alarms may be selected as critical or non-critical for segregating inputs into a common alarm relay output on the CSM. The CSM has separate relays for critical or non-critical horns, reflash and fault outputs. Any input in the system selected for critical or non-critical will activate the respective CSM relay output. By default, all alarms are set as non-critical.

Modbus Transmit or Receive (Optional)

If the Modbus option is included with your system, every input is defined for Transmit or Receive by clicking on the button. Transmit implies that the alarm status from hardwired contacts are sent serially to some other device. Receive

implies that some other serial device is providing the status of the alarm and the Annunciator will respond as if it were a field contact input. You may choose combinations of transmit and receive, but a single input cannot do both. You may also set up an input as receive while providing a hard-wired contact input to the same point. In this case, the Annunciator will respond to alarms from either the contact or serial input in a logic OR arrangement. If the option is not available this button is not displayed. It may also not be displayed if creating a new configuration. You must connect to your Annunciator to enable the serial Modbus configuration.

Note: Systems with Serial Inputs only (not Hardwired) cannot be set to 'transmit'.

Panel Colors

The color of each input in the mimic diagram may be changed to match the actual annunciator. To do this select all the inputs with the same color as described above then click on 'Panel Colors'. From the color selector dialog choose any color. The custom colors represent the available window colors. Repeat this for each color.

Table View

Click on the Table View button to display the current input configuration in a table format. This is designed to be a summary of all the input configuration, but by clicking on the individual items you can change the selection from the table.

The column widths may be adjusted by clicking and dragging on the vertical separators between the column titles.

Alarm No.	Relay Mode	Alarm Group	Input Delay	Critical	Hardwired	Data Direction
1	Fault to Reset - De-energised	3	10,000	Critical	Yes	Receive
2	Fault to Reset - De-energised	3	10,000	Critical	Yes	Transmit
3	Fault to Reset - De-energised	3	10,000	Critical	Yes	Transmit
4	Fault to Clear - Energised	3	10,000	Critical	Yes	Transmit
5	Fault to Reset - De-energised	3	10,000	Critical	Yes	Receive
6	Fault to Reset - De-energised	3	11,000	Critical	Yes	Receive
7	Fault to Reset - De-energised	3	12,000	Critical	Yes	Transmit
8	Fault to Reset - De-energised	3	13,000	Critical	Yes	Transmit
9	Fault to Reset - De-energised	3	14,000	Critical	Yes	Receive
10	Fault to Clear - De-energised	1	15,000	Critical	Yes	Receive
11	Fault to Clear - De-energised	1	16,000	Non-critical	Yes	Receive
12	Fault to Clear - De-energised	1	17,000	Non-critical	Yes	Receive
13	Fault to Clear - De-energised	1	18,000	Non-critical	Yes	Transmit
14	Fault to Clear - De-energised	1	19,000	Non-critical	Yes	Receive
15	Fault to Clear - De-energised	1	20,000	Non-critical	Yes	Receive
16	Fault to Clear - De-energised	1	21,000	Non-critical	Yes	Receive
17	Fault to Clear - De-energised	1	22,000	Non-critical	Yes	Receive
18	Fault to Clear - De-energised	1	23,000	Non-critical	Yes	Receive
19	Fault to Clear - De-energised	1	24,000	Non-critical	Yes	Receive
20	Fault to Clear - De-energised	1	25,000	Non-critical	Yes	Transmit
21	Fault to Clear - De-energised	1	26,000	Non-critical	Yes	Transmit
22	Fault to Clear - De-energised	1	27,000	Non-critical	Yes	Transmit
23	Fault to Clear - De-energised	1	28,000	Non-critical	Yes	Receive
24	Fault to Clear - De-energised	1	29,000	Non-critical	Yes	Receive

Lamp Configuration

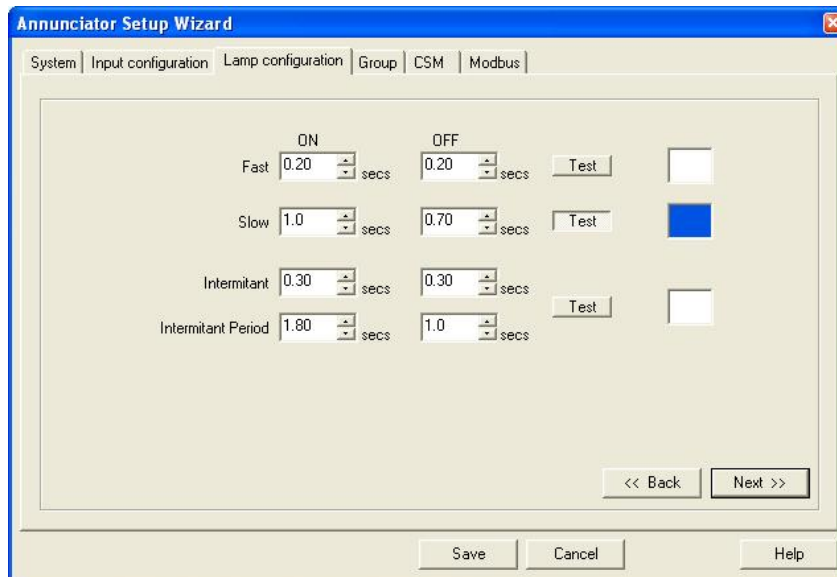

The lamp flash rates are defined in this page. The operational sequence chosen determines whether a slow, fast or intermittent flash rate is used. For example; Sequence F3A uses all three rates while Sequence A uses only the slow flash rate.

Click on the up or down arrows beside each number to increment or decrement it. Click and hold on the arrows to scroll up or down. Click on the 'Test' button to check the appearance of each flash rate.

Fast & Slow flash rates

The ON and OFF times are set up with a resolution of 0.1s. The maximum times are 4s.

Intermittent rate

The Intermittent period values will be automatically adjusted to ensure they are integer multiples of the sum of the Intermittent ON and OFF times. The maximum Intermittent Period ON and OFF values are 25s.

Note:

The **intermittent on period** may be adjusted automatically by the wizard so that it is set to at least one full intermittent on - off cycle.

Sequence

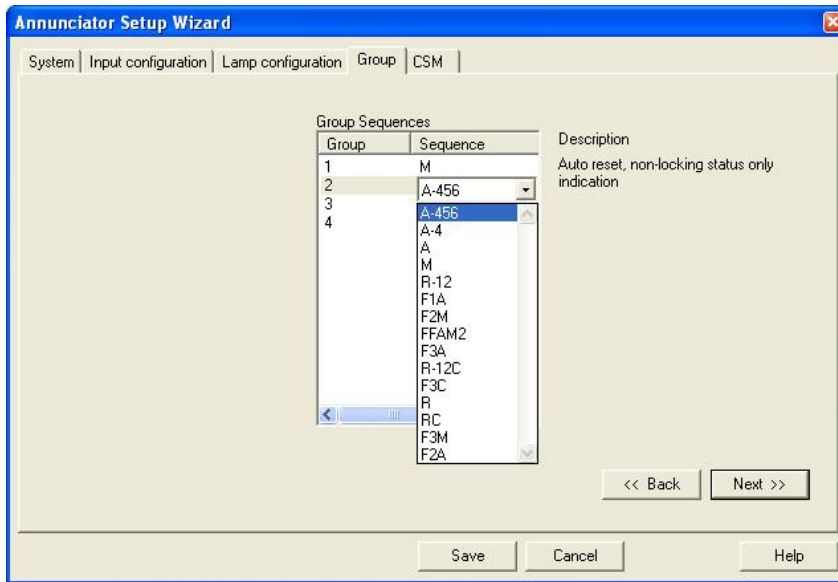

The alarm sequence for each input group is defined in this page. The Input Configuration page was used to indicate which of the four available groups was assigned to each input. This page identifies the sequence chosen for each group.

Note: The four available groups can be set up for the same First-Out Sequence, but each group is treated separately as its own first out group.

To change the alarm sequence, click on the entry then choose the sequence from the list. The alarm sequences shown below follow ISA Standard S18.1 – 1979

ISA-A	Automatic reset with lock-in of alarms
ISA-A-4	Automatic reset with no lock-in of alarms
ISA-A-4-5-6	Automatic reset, non-locking, no flash, no audible, NO PB
ISA-M	Manual Reset with lock-in of alarms
ISA-F1A-1	First Out Flash, Subsequent alarm steady, auto reset
ISA-F2A-1	First Out, Fast Flash, auto reset
ISA-F2M-1	First Out, no subsequent alarm flash, manual reset
ISA-F3A	First Out, triple flash, first out reset
ISA-F3M	First out, triple flash, first out manual reset
ISA-F3C	First out, triple flash, dual color, manual reset
ISA-FFAM2	First Out, manual reset
ISA-R	Ringback, separate flash for return to normal
ISA-RC	Ringback, separate color for return to normal
ISA-R-12	Automatic Momentary Ringback, dual flash, manual reset
ISA-R-12C	Ringback, dual color flash, manual reset

CSM (Common Service Module)

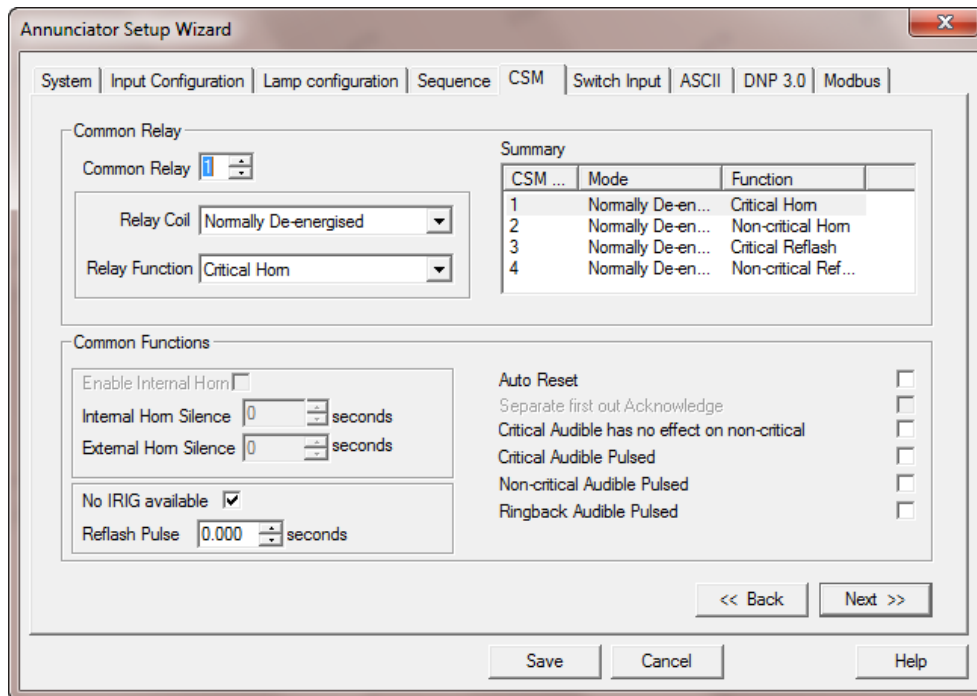

The functions of the CSM are defined in this page.

Common Relay

There are 2 relays in the CSM and an additional 2 can be provided with option **RLY**. Each relay mode may be defined as either Energized or De-Energized, with respect to the power on, normal state. For example, an Energized Relay has a coil that is energized when power is applied and there is no alarm. When the output is activated, the coil will de-energize, transferring the contact output. The Standard relay functions may be selected from:-

Critical horn Auxiliary horn output driven by any alarm selected as critical. The horn relay output will return to its normal state upon activation of the silence or acknowledge pushbutton.

Non-critical horn Auxiliary horn output driven by any alarm selected as non-critical. The horn relay output will return to its normal state upon activation of the silence or acknowledge pushbutton. Note: If a critical horn is used in addition to the non-critical horn, the critical horn has priority. For example; if the non-critical alarm is on and the Annunciator receives a critical alarm, the non-critical horn will turn off and the critical horn will turn on. When the critical horn is silenced, any new non-critical alarms will activate the non-critical horn. This operation can be changed in the common functions below.

Ringback (clear horn) An output driven by the return to normal of an alarm input. Operated by sequences R, RC, R12 and R12C only.

The following functions are included with the **RLY** Relay Option:

Critical Reflash Grouped output driven by any alarm selected as critical. Upon a critical alarm, the relay output changes state. Every new critical alarm will pulse the relay output for approximately ½ second. The relay output will return to its normal state when all critical alarms have returned to normal.

Non-Critical Reflash Grouped output driven by any alarm selected as non-critical. Upon a non-critical alarm, the relay output changes state. Every new non-critical alarm will pulse the relay output for approximately ½ second. The relay output will return to its normal state when all critical alarms have returned to normal.

Critical Fault This relay output will change state when any critical input is in the alarm state. The relay output will only return to its normal state when all critical alarms have returned to normal. The relay output is not affected by the silence or acknowledge pushbutton.

Non-Critical Fault This relay output will change state when any non-critical input is in the alarm state. The relay output will only return to its normal state when all non-critical alarms have returned to normal. The relay output is not affected by the silence or acknowledge pushbutton.

Power Fail This relay output will change state when the Power is lost. The relay coil is energized upon start-up and the contacts will transfer upon a loss of power.

Ground Fault This relay output will change state when a ground fault condition is detected. (Note: Must have Ground Fault Detector Option GF) The ground fault can be either a positive ground (+FCV wire to ground) or a negative ground (FCV return wire to ground).

Watchdog System healthy output. It will activate when the system is not processing alarms, like during the configuration process or when there is a system failure. The Watchdog will detect when there is a remote communication failure, if Modbus or DNP are used. The communication failure would activate after a period of inactivity, including a disconnected or broken cable.

The Configuration Screen will show a summary of the Common Relay functions to the right. To select a relay to edit use the up or down arrows beside the relay number or click on the entry in the summary.

Note: In addition to these configurations, the repeat relay contact may be selected as a Form A or (Normally Open) or Form B (Normally Closed) using the I/O jumpers described in the previous section.

Common Functions

A number of system-wide functions are available through the Common Service Module. To select a function click on the white box to the right of the name so as a tick mark appears. To turn the function off click on the box again so as the tick is removed. The available functions are:-

Enable Internal Horn (Option HN)

When selected, this will activate the internal audible device upon any non-critical or critical horn condition.

Internal Horn Silence (option AS)

The internal horn (option HN) may be automatically silenced after a fixed time. To do this use the up and down arrows to the right of the value box to set the required time. The maximum value is 240s and the resolution is 1.0s.

Note: A setting of 0 indicates that the auto-silence is not activated.

External Horn Silence (Option AS)

This will silence any external horn if selected for CSM Relay #1-4 in the time increment selected. This will automatically silence the Critical, Non-Critical or Ringback Horn when this option is included with the system. The maximum value is 240s and the resolution is 1.0s.

Note: A setting of 0 indicates that the auto-silence is not activated.

Auto Reset

This will activate the Reset function continuously, eliminating the need to manually press this. (Note: this only applies to alarm sequences that require the reset function.)

Critical Audible has no affect on non-critical

This will make the operation of the non-critical horn independent of the critical horn. See the previous section on the operation of the non-critical audible.

Critical Audible Pulsed

This will pulse the critical audible output upon an alarm.

Non-critical Audible Pulsed

This will pulse the non-critical audible output upon an alarm.

Ringback Audible Pulsed

This will pulse the ringback audible output upon an alarm.

Switch Inputs

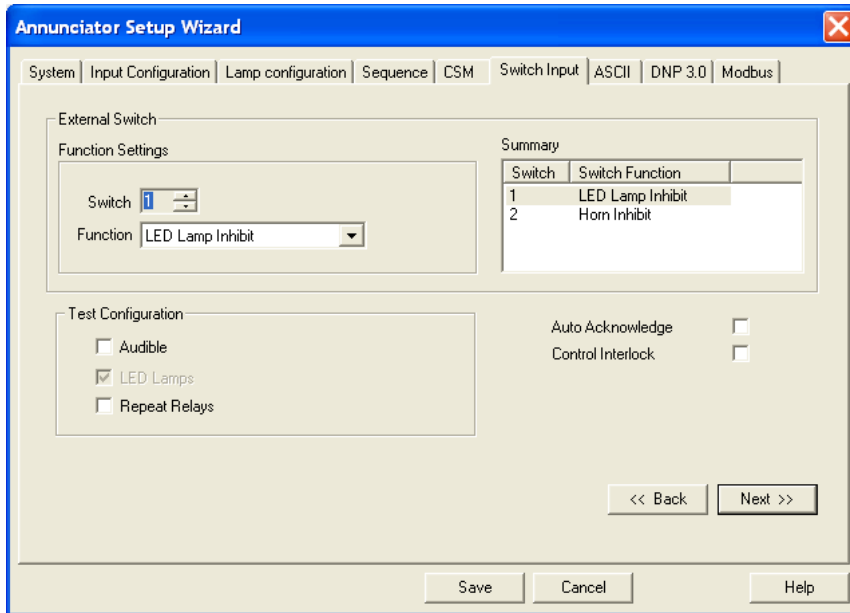

This screen is used to set up the optional External Switch Inputs (Option SW). The External Switch Inputs provide several inhibit functions that are commonly used when the system is left in an 'in-manned state' and there is no need to flash alarms or sound horns. There are other configurations available on this page to configure the Test Pushbutton Operation.

External Switch Function Settings

LED Lamp Inhibit

If selected, whenever the switch is closed, all LED Lamps in the system will be disabled. If the operational sequence chosen latches the alarm (A, M, etc.), any alarms that occurred while the inhibit switch was enabled as well as any current alarms will be displayed as soon as the switch returns to the 'off' position.

Horn Inhibit

If selected, whenever the switch is closed, all Horns in the system will be disabled. (This includes the internal horn and external horns connected to the CSM Relay outputs.) If the operational sequence chosen latches the alarm (A, M, etc.), any alarms that occurred while the inhibit switch was enabled as well as any current alarms will be sounded as soon as the switch returns to the 'off' position.

Repeat Relay Inhibit

If selected, whenever the switch is closed, all Repeat Relays in the system will be disabled. If the operational sequence chosen latches the alarm (A, M, etc.), any alarms that occurred while the inhibit switch was enabled as well as any current alarms will operate as soon as the switch returns to the 'off' position.

Inhibit all CSM Relay Outputs

If selected, whenever the switch is closed, all CSM Repeat Relay Outputs (Horns, Reflash and Fault) will be disabled. If the operational sequence chosen latches the alarm (A, M, etc.), any alarms that occurred while the inhibit switch was enabled as well as any current alarms will operate as soon as the switch returns to the 'off' position.

Test Configuration

The following functions can be activated when the Test Pushbutton is used. It applies to the Integral Test Pushbutton on the CSM Module (Option INTB, LPPB) and to an external Test Pushbutton wired into the Annunciator.

1. Audible If selected, the audible outputs (critical, non-critical and ringback horn) will be activated during the Test Function.
2. LED Lamps: The LED Lamps will always be activated during the Test Pushbutton. There is no selection to deactivate this.
3. Repeat Relays: If selected, the Repeat Relay outputs will be activated during the Test Function.

Other System Configurations

Auto Acknowledge This will activate the acknowledge function continuously, eliminating the need to manually press this. (Note: by selecting this, you will never get any horn outputs and flashing lamps, depending on the sequence selected.)

Control Interlock This requires that the Silence, Acknowledge and Reset pushbuttons are pressed in this exact order. Anything else will be ignored. For example; if the Acknowledge pushbutton is pressed before the Silence, it will not have any effect. (Note: If the Reset function is not required for the alarm sequence selected, it will be ignored.)

ASCII

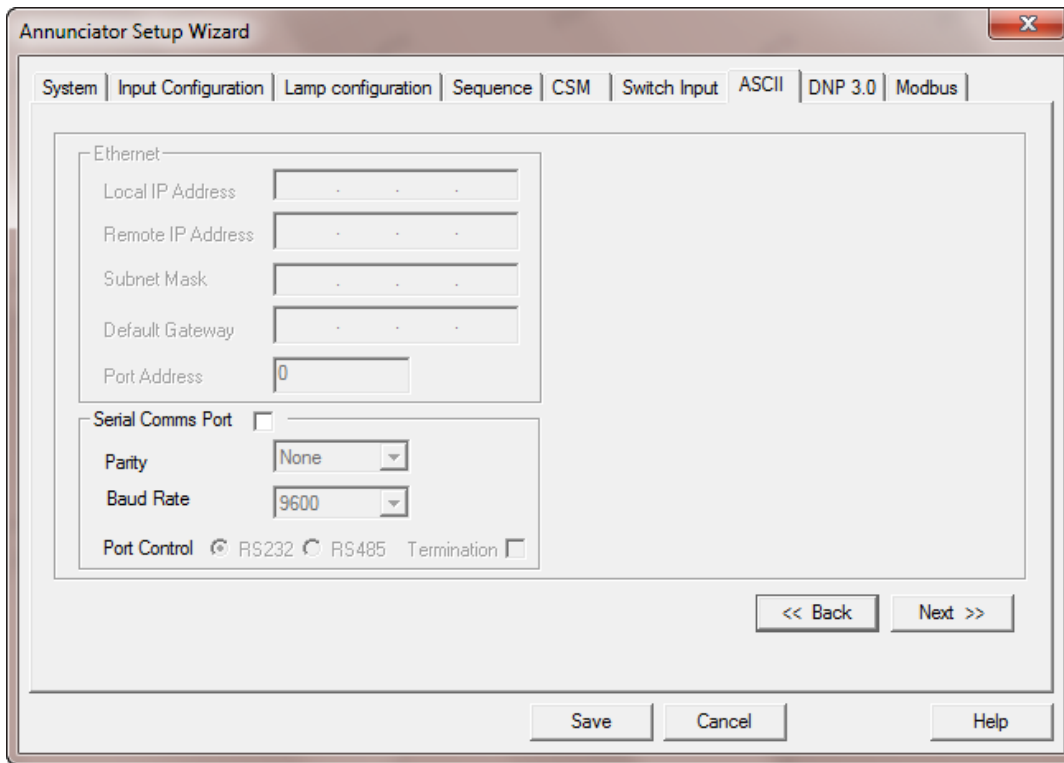

The only setting required for ASCII Protocol is to enable the Serial Comms Port.

Settings for Serial Port (Option SPT)

Note: The Serial Comms Port selection must be one of; ASCII, Modbus, or DNP. Turning on ASCII Serial Comms turns off Modbus and DNP Serial Comms

Parity

The parity for the serial communications may be selected from:-

- None
- Odd
- Even

The configuration application will always use the parity defined for the AN-3200. If the parity is changed it will not take effect until the current configuration session is complete.

Baud Rate

The ASCII baud rate may be selected from :-

- 1200
- 2400
- 4800
- 9600
- 19200

The configuration application will always use the baud rate defined for the AN-3200. If the baud rate is changed it will not take effect until the current configuration session is complete.

Port Control

The ASCII port may be selected from:

- RS-232
- RS-485

In addition the RS-485 termination may be enabled

The configuration application will always use the baud rate defined for the AN-3200. If the baud rate is changed it will not take effect until the current configuration session is complete.

Modbus

Default values of the Modbus settings are given in Appendix B

The screenshot shows the 'Modbus' tab of the 'Annunciator Setup Wizard'. The window has a title bar with a close button. Below the title bar is a navigation bar with tabs: System, Input Configuration, Lamp configuration, Sequence, CSM, Switch Input, ASCII, DNP 3.0, and Modbus. The main area is divided into two columns. The left column is titled 'Ethernet' and contains fields for: Local IP Address (192 . 168 . 250 . 101), Remote IP Address (192 . 168 . 250 . 102), Subnet Mask (255 . 255 . 0 . 0), Default Gateway (0 . 0 . 0 . 0), and Port Address (0, with a note '(default = 502, disabled = 0)'). Below these is a 'Serial Comms Port' section with a checked checkbox, a 'Parity' dropdown (None), a 'Baud Rate' dropdown (9600), and 'Port Control' options: RS232 (selected), RS485, and Termination (unchecked). The right column is titled 'Transmission' and contains: Modbus Mode (Slave), Data Type (Point), Modbus Address (1), Receive Start Address (40001), Transmit Start Address (40001), and Transmit Controls (checked). At the bottom of the wizard are buttons for '<< Back', 'Finish', 'Save', 'Cancel', and 'Help'.

The Modbus settings consist of setting up the Ethernet or Serial Port Option and the Modbus Transmission modes.

Settings for Ethernet (Option ETH)

Local IP Address

This is the static IP address to be assigned to the annunciator so that it can be located on a network.

Remote IP Address

When the annunciator is operating in Master mode this is the address to which it will send data requests.

Subnet Mask

To allow the annunciator to be successfully connected to your network you will have to provide the correct subnet mask. If you do not know the correct subnet mask then you should contact your network administrator.

Default Gateway

Please contact your network administrator to find out whether you need to set a gateway to successfully connect to your network.

Port Address

Select the Port Address of the host system on the network.

If you are not going to be using Modbus over ethernet set the Port Address to 0 (disabled) to prevent a communications fault, which could cause a false watchdog trip, and a false REMOTE COMM LED indication.

Settings for Serial Port (Option SPT)

Note: The Serial Comms Port selection must be one of; ASCII, Modbus, or DNP. Turning on Modbus Serial Comms turns off ASCII and DNP Serial Comms

Parity

The parity for the serial communications may be selected from:-

- None
- Odd
- Even

The configuration application will always use the parity defined for the AN-3200. If the parity is changed it will not take effect until the current configuration session is complete.

Baud Rate

The Modbus baud rate may be selected from :-

- 1200
- 2400
- 4800
- 9600
- 19200

The configuration application will always use the baud rate defined for the AN-3200. If the baud rate is changed it will not take effect until the current configuration session is complete.

Port Control

The Modbus port may be selected from:

- RS-232
- RS-485 9600 and 19200 baud only in slave mode

In addition the RS-485 termination may be enabled

The configuration application will always use the baud rate defined for the AN-3200. If the baud rate is changed it will not take effect until the current configuration session is complete.

Common Modbus Settings

Modbus Address

In master mode, this is the address of the slave annunciator that the master will connect to. In slave mode this address is the annunciators own local Modbus address. Every system on a common serial bus must be given a unique address. Valid addresses are from 1 to 255.

Receive & Transmit Start Address

This defines the base register address for sending and receiving information.

Advisory

In some systems it may be necessary to separate the receive and transmit registers by address to avoid overwrites. When operating in modbus master mode the system will alternately transmit (FN16) and receive (FN03) register data at approximately 0.5sec intervals. In some systems point data may be overwritten before it can be forwarded if receive and transmit registers are the same. In this case it is suggested that separate transmit and receive registers are used e.g. 40001 and 40017.

Modbus Mode

The Modbus Mode may be selected from:-

- Master
- Slave

A Master unit may issue command functions and a slave unit responds to them. When the AN-3200 configuration application is being used the AN-3200 will be in slave mode independent of its Mode setting.

Data Type

The Modbus Data Type may be selected from:-

AN3135 Style Point
Point
State

State must be selected.

Reference Appendix B for a complete description of these Data Types.

Transmit Controls

If this option is selected, Acknowledge and Reset Pushbutton controls will be transmitted along with point data. (When communicating between two Annunciators, only one Annunciator may be set to Transmit Controls. As a default, the Annunciator will always accept or receive pushbutton controls from another device regardless if the Transmit Controls option is selected.

The Series 90A can transfer annunciator controls (ACK and RST) via modbus. This can be done in two modes of operation, namely 3135 and Point data. In Point mode the controls are within register 16 after 15 registers of alarm points. In 3135 they are in register 5 after 4 of alarms. To avoid overwriting when master and slave are using the same register addresses the bits used to transfer the controls are different between master and slave mode. The bits used are indicated in the table below.

	RST incoming	ACK incoming	RST outgoing	ACK outgoing
Slave	0x0001	0x0002	0x0004	0x0008
Master	0x0004	0x0008	0x0001	0x0002

Modbus Type

This is a format in which the data is transmitted. Can be set to ASCII or RTU.

DNP3.0

The screenshot shows the 'Annunciator Setup Wizard' window with the 'DNP 3.0' tab selected. The window is divided into several sections for configuration:

- Ethernet:** Local IP Address (192 . 168 . 250 . 101), Remote IP Address (192 . 168 . 250 . 102), Subnet Mask (255 . 255 . 0 . 0), Default Gateway (0 . 0 . 0 . 0), Port Address (0) (default = 20000, disabled = 0).
- Serial Comms Port:** Checked, Parity (None), Baud Rate (9600), Port Control (RS232 selected, RS485 unselected), Termination (unchecked).
- Transmission:** IED Address (1), Transmission Delay (1).
- Data Link Confirm:** Confirm Mode (Never), Retries (1), Timeout (1), Select/Operate Arm Timer (1).

Navigation buttons include '<< Back', 'Next >>', 'Save', 'Cancel', and 'Help'.

The DNP settings consist of setting up the Ethernet or Serial Port Option and the Modbus Transmission modes.

Settings for Ethernet (Option ETH)

Local IP Address

This is the static IP address to be assigned to the annunciator so that it can be located on a network.

Remote IP Address

When the annunciator is operating in Master mode this is the address to which it will send data requests.

Subnet Mask

To allow the annunciator to be successfully connected to your network you will have to provide the correct subnet mask. If you do not know the correct subnet mask then you should contact your network administrator.

Default Gateway

Please contact your network administrator to find out whether you need to set a gateway to successfully connect to your network.

Port Address

Select the Port Address of the host system on the network.

If you are not going to be using DNP over ethernet set the Port Address to 0 (disabled) to prevent a communications fault, which could cause a false watchdog trip, and a false REMOTE COMM LED indication.

Settings for Serial Port (Option SPT)

Note: The Serial Comms Port selection must be one of; ASCII, Modbus, or DNP. Turning on DNP Serial Comms turns off ASCII and Modbus Serial Comms

Parity

The parity for the serial communications may be selected from:-

- None
- Odd
- Even

The configuration application will always use the parity defined for the AN-3200. If the parity is changed it will not take effect until the current configuration session is complete.

Baud Rate

The DNP baud rate may be selected from :-

- 1200
- 2400
- 4800
- 9600
- 19200

The configuration application will always use the baud rate defined for the AN-3200. If the baud rate is changed it will not take effect until the current configuration session is complete.

Port Control

The DNP port may be selected from:

- RS-232
- RS-485

In addition the RS-485 termination may be enabled

The configuration application will always use the baud rate defined for the AN-3200. If the baud rate is changed it will not take effect until the current

configuration session is complete.

Common DNP Configuration Settings

IED Address

This is a number used to identify the recorder on the network (range 1 - 65534).

Transmission delay

This is the time to disable the master transmitter on an RS485 network (range 0 - 65535) (not currently used).

Data Link Confirm

This can be set as Never, Sometimes or Always. The default value is Never.

Retries

This is the number of times the recorder will retry to connect if Data Link confirmation is required (range 0 - 255)

Timeout

This is the time the IED will wait for a Data Link confirmation. Valid numbers are 0 - 65535.

Select/Operate arm time

This is the time period after the select command is received that the operate command will be performed (range 0 - 65535) (Not currently used)

Quick Access

Toolbar

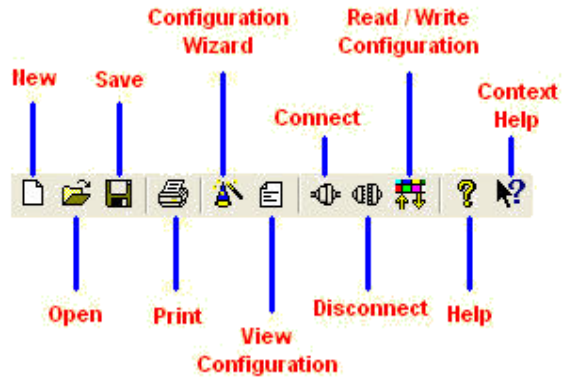

Hot Keys

Action	Hot Key
New Document	CTRL + N
Open Document	CTRL + O
Save	CTRL + S
Print Configuration	CTRL + P
View Configuration	CTRL + V
Connect	CTRL + C
Disconnect	CTRL + D
Create Duplicate	CTRL + R
Connection Status	CTRL + T
Run Wizard	CTRL + W

SYSTEM SPECIFICATIONS

Inputs

Field Contacts

Normally Open (N.O.) or Normally Closed (N.C.)
Input selection through Software or Field Selectable Jumper
Wet (voltage supplied) or dry (voltage free) contacts

Field Contact Voltage (FCV)

Common FCV or FCV Isolated Input to Input (Jumper Selectable)
12, 24, 48, 125 VDC, 120 VAC or 24VDC open collector
Input Current Requirement: 0.0018 mA per input
FCV Disconnect for an alarm when the I/O Module is removed (other alarms unaffected)

Input Isolation

Each input is optically isolated

Input Response

1 millisecond	(Fast Response, Option FR. Also used with SER option)
50 milliseconds	Standard Response
50 msec to 250 seconds	Adjustable in Software in 50 msec or 1 second increments

Display

Window Sizes

Full Size (1 per Cell):	3.0 x 3.0"	(76 x 76mm)
Half Size (2 per Cell):	1.5 x 3.0"	(38 x 76mm)
Third Size (3 per Cell):	1.0 x 3.0"	(25 x 76mm)
Quad Size (4 per Cell):	1.5 x 1.5"	(38 x 38mm)

Illumination

White LED 20 mA @5VDC

Full Size Windows	8 LED's / Input
Half Size Windows	4 LED's / Input
Third Size Windows	2 LED's / Input
Quad Size Windows	2 LED's / Input

Window Color

White, Red, Yellow, Amber, Green, Blue

Legends

Laser printed on transparency film or Engraved

Repeat Relay Outputs

Repeat Relay Option RR

Individual relay per point

Follows field contact or alarm sequence, selectable in Software
Energized or de-energized Relay Coil, selectable in Software
Form A or Form B (N.O. or N.C.) Contact, selectable by Jumper
-Available with all window sizes

Repeat Relay Option 2RR

Two repeat relays per point

Follows field contact or alarm sequence, selectable in Software
Energized or de-energized Relay Coil, selectable in Software
Form A or Form B (N.O. or N.C.) Contact, selectable by Jumper
-Available with full or half size (option 2S) windows

Repeat Relay Option FRC

Individual repeat relay per point

Follows field contact or alarm sequence, selectable in Software
Energized or de-energized Relay Coil, selectable in Software
Form C (SPDT) Contact, selectable by Jumper
-Available with full or half size (option 2S) windows

Relay Operation

Follows Field Contact:	Repeat Relay Output Follows Input Contact State
Follows Alarm Sequence:	Repeat Relay Output Latches on Alarm until Acknowledged or Reset
Follows Alarm Display:	Repeat Relay Output toggles on and off following operation of window

Relay operation selectable in Software per point

Relay Ratings:

24VDC @ 3.0 Amps
110VDC @ 0.1 Amps
120VAC @ 3.0 Amps
Resistive Load

Alarm Sequence

Sequence Selections

Standard ISA Sequences: A, A4, A4-5-6, M, F1A, F2A, F2M, F3A, F3M, FFAM2, R, R-12

Dual Color Sequences: F3C, RC, R-12C

Up to 4 Sequences per system

Sequence configured in Software (by input)

Customized flash rates

100 millisecond increments (Selectable in Software)

First Out Groups

Up to 4 first out groups per system

5 millisecond First Out Discrimination

Lamp Synchronization

Synchronize other displays to same flash rate. Master system outputs a pulse at the slow flash rate. Slaves re-sync to incoming "lamp off" edge. A master system may drive up to 5 slave units.

Controls

Pushbuttons

Integral Pushbutton Option (INTB, LPPB): Test, Acknowledge, Silence and Reset

(4) External Pushbutton Inputs: Test, Acknowledge, Silence and Reset
5VDC @0.002 mA per Pushbutton
(provided by Annunciator)

Switch Input (Option SW)

Software configurable for:

Inhibit of LED Lamps, Horn, Repeat Relay Outputs or CSM Common Relay Outputs
5VDC @0.002 mA (provided by Annunciator)

System Relays

Alarm Grouping

Critical or Non-Critical Alarms: Selectable in software per input
Used to provide separate horns, or other relay outputs
Critical Alarms have priority over Non-Critical (can be disabled)

Standard Relays

(2) Relays Software Configurable for:
Critical or Non-Critical Horn, Ringback Horn
Energized or De-Energized Relay Coil, selectable in Software
Form A or Form B (N.O. or N.C.) Contact, Selectable by Jumper

Optional Relays (Option RLY)

(2) Additional Relays Software Configurable for:
Critical or Non-Critical Horn, Ringback Horn, Critical or Non-Critical Reflash,
Critical or Non-Critical Fault, Power Fail, System Watchdog, or Ground Fault
Detect)
Energized or De-Energized Relay Coil, selectable in Software
Form A or Form B (N.O. or N.C.) Contact, Selectable by Jumper

Relay Ratings:

24VDC @ 3.0 Amps
110VDC @ 0.1 Amps
120VAC @ 3.0 Amps
Resistive Load

Audible Devices

Internal 80db @ 30cm audible device (option HN)
External Audible Devices available

Communications

Communication Ports

Option	RS-232/485 Serial Port	Ethernet Port
SPT	✓	
ETH		✓
SPT-ETH	✓	✓

Communication Protocol Options

Function	Option SIM	Option MB	Option DNP	Option SD
	Modbus Input Only	Modbus Input & Output	DNP Output	Serial ASCII Output
Transmit Alarm Status via Serial Data	No	Yes	Yes	Time stamped alarms only
Receive Alarm Status via Serial Data	Yes	Yes	No	No
RTU or ASCII Mode	Yes	Yes	N/A	N/A
Master Mode	Yes	Yes	No	N/A
Slave Mode	Yes	Yes	Yes	N/A
Transmit Local Pushbutton Controls	Yes	Yes	Yes	No
Receive Remote Pushbutton Controls	Yes	Yes	Yes	No
RS-232 / 485 (Option SPT)	Yes	Yes	Yes	Yes
Ethernet (Option ETH)	Yes	Yes	Yes	No

Time Stamped Alarms

Sequential Events Recording

(Option SER, SERFR)

Time Stamp Resolution:	1 or 4 millisecond (depending on option selected)
Time Set Method:	Through Configuration Software
Time Synchronization:	Internal Clock (accurate to 10 seconds per day) Optional IRIG-B Module (accurate to 1msec)
Data Output:	Modbus, DNP or ASCII
Data Format:	Point Number, Point Status, Time & Date of alarm and subsequent return to normal.
Event Storage:	500 Events (FIFO buffer) (an event can be a point on alarm or a point that returns to normal)
Note:	Event memory is volatile – It requires power at all times. Power loss will clear the event buffer.

Indicators

SYSTEM STATUS

This Green LED is on when the Common Service Module (CSM) is operating properly

LED FAIL

This Red LED will light when a defective lamp is detected

REMOTE COMM

This Green LED will indicate the status of the communications ports

On steady: Both serial and ethernet port activity

Slow flash: Ethernet port activity, no serial port activity

Fast flash: Serial port activity, no ethernet port activity

Off: No activity on either the serial port or the Ethernet port

GROUND FAULT

This Red LED is on when the optional Ground Fault detector module detects a fault.

Power Requirements

Input Power

19-29 VDC	(Option F	24VDC)
38-58 VDC	(Option E	48VDC)
100-250 VDC	(Option C	125VDC)
88-132 VAC, 60 Hz	(Option B	120VAC)
176-264 VAC, 50 Hz	(Option A	230VAC)

Input Burden: Maximum 2.2 Watts/point (depends on window size and options selected)

Mechanical

Enclosures: Semi-flush Panel Mount,
 19" Rack Mount,
 Surface (wall) mount,
 NEMA Enclosures

Size: Depends on Annunciator Configuration (# of cells high x wide)

Weight: 1.5 LB per cell (0.8kg per cell)

Connections / terminations

Field Contact Input, Relay Output, Power Input Terminals

- Barrier Terminal Block, #6-32 screw. Accepts Ring, Spade Lug or Bare Wire
- Wire size: 12-22 AWG

Pushbutton/Switch Input, Lamp Synchronization Terminals

- Barrier Terminal Block, #6-32 screw. Accepts Ring, Spade Lug or Bare Wire
- Wire size: 14-22 AWG

Serial Communication Port(s)

- 9 Pin Female D connector

Ethernet Communication Port

- RJ45 connector

IRIG-B Time Synchronization Input

- BNC connector

Environment

Operating Temperature Range:	-20 TO 50 °C (-4 to 122°F)
Storage Temperature Range:	-20 TO 80 °C (-4 to 176°F)
Humidity:	20-95% RH

Electrical

Surge Withstand: ANSI C37.90.1 (Oscillatory portion)
Electrical Fast Transient/Burst Immunity:
IEC 61000-4-4 (2kV DC Power, 1kV I/O)
Surge Immunity: IEC 61000-4-5 (1kV Common Mode, line-to-ground)

Dielectric Withstand:

1400 Vac or 2050 Vdc Inputs to Digital (test @ configuration port)
1400 Vac or 2050 Vdc Outputs to Digital (test @ configuration port)
1450 Vac or 2150 Vdc AC Integral Power Input to Digital (test @ configuration port)
350 Vac or 500 Vdc DC Integral Power Input to Digital (test @ configuration port)
1400 Vac or 2000 Vdc from Inputs to Outputs
1400 Vac or 2000 Vdc from Inputs to Power Input
250 V RMS from Input to Input when configured for Isolated Inputs
1400 Vac or 2000 Vdc from Outputs to Power Input
1200 Vac or 1700 Vdc from Output to Output
1400 Vac or 2000 Vdc from Inputs to Case
1200 Vac or 1700 Vdc from Outputs to Case
1400 Vac or 2000 Vdc from Integral AC Power to Case
350 Vac or 500 Vdc from Integral DC Power to Case
350 Vac or 500 Vdc from Communications Ports to DC Power
1450 Vac or 2150 Vdc from Communications Ports to AC Integral Power Input

Radiated RFI Immunity: IEC 61000-4-3 10 V/m
Conducted RFI Immunity: IEC 61000-4-6 3V
Radiated Emissions: EN 61000-6-4 (EN55011)
Conducted Emissions: EN 61000-6-4 (EN55011)
Radiated Power Frequency: IEC 61000-4-8 30 A/m Magnetic Field
ESD Effects: IEC 61000-4-2 4kV contact 8kV air

Certifications

CE: Low Voltage Directive 73/23/EEC: EN 61010-1:2001
EMC Directive 89/336/EEC: EN 61326:1998
FM¹ Pending
UL Pending

¹ Requires FM option (refer to option codes). The required door may be supplied by Ametek, a panel shop or the customer. The door must meet the FM standard for requiring a tool to open or remove the door to allow access to the front of the Annunciator.

SERVICING

Ensure that the power supply to the unit is switched off before servicing.

MODULE REMOVAL

When removing a module for replacement or configuration, it is best to shut off the power to prevent any false alarms or electric shock. When replacing any board, note the jumper settings and transfer them to the replacement module. If in doubt, refer to the module set-up instructions in this manual.

CAUTION

Note and record the window positions when removed from the chassis so as to ensure that the windows are replaced in their original locations

Severe problems/damage could occur to monitored plant/equipment should windows be replaced in incorrect positions causing erroneous indication of alarms

Only remove one window assembly at a time to minimize the possible incorrect repositioning of alarm display windows

ESD

ESD (Electrostatic Discharge) can damage sensitive electronics when they are being handled or touched. The Annunciator has been protected against certain levels of ESD when touching the outside case or terminals. The internal electronics may be susceptible to ESD when handled, so proper care should be given to any exposed electronics or circuit boards. The following guidelines should be used to prevent any build-up of ESD and to minimize the products exposure to it.

1. Prevent static build-up by using conductive paints, carpeting, mats and metal surfaces. Use appropriate grounding techniques, including wrist and heel straps for personnel.
2. Store or transport electronic devices, parts or assemblies in conductive bags or bins.
3. Only perform repairs at an appropriate repair station.
4. When handling electronic assemblies or printed circuit boards, try to avoid touching traces on the printed circuit board or static sensitive devices.
5. Remember that tools are a source of static electricity. Only use grounded soldering irons. Ground tools before using them to bleed off any charge build-up.
6. Discharge yourself before touching or handling any electronic assembly or device. This can be done by touching a good ground point before touching any electronic devices or assemblies. Preferably, discharge any static charge through a high impedance such as a wrist or heel strap.

APPENDIX A

OPERATIONAL SEQUENCES

The following are summary sequence descriptions provided for guidance.

AUTO RESET, NON LOCKING STATUS ONLY INDICATION						
SEQUENCE CODE	ALARM DEVICE	NORMAL	ALERT	ACKNOWLEDGE	RETURN TO NORMAL	RETURN TO NORMAL BEFORE ACK
A-456	VISUAL					
	AUDIBLE					

AUTO RESET, NON LOCKING						
SEQUENCE CODE	ALARM DEVICE	NORMAL	ALERT	ACKNOWLEDGE	RETURN TO NORMAL	RETURN TO NORMAL BEFORE ACK
A-4	VISUAL					
	AUDIBLE					

AUTO RESET, LOCKING							
SEQUENCE CODE	ALARM DEVICE	NORMAL	ALERT	ACKNOWLEDGE	RETURN TO NORMAL	RETURN TO NORMAL BEFORE ACK	ACKNOWLEDGE
A	VISUAL						
	AUDIBLE						

MANUAL RESET, LOCKING								
SEQUENCE CODE	ALARM DEVICE	NORMAL	ALERT	ACKNOWLEDGE	RETURN TO NORMAL	RETURN TO NORMAL BEFORE ACK	ACKNOWLEDGE	RESET
M	VISUAL							
	AUDIBLE							

RINGBACK, DUAL FLASH, MANUAL RESET								
SEQUENCE CODE	ALARM DEVICE	NORMAL	ALERT	ACKNOWLEDGE	RETURN TO NORMAL	RETURN TO NORMAL BEFORE ACK	ACKNOWLEDGE	RESET
R-12	VISUAL		 FAST		 SLOW	 SLOW	 SLOW	
	AUDIBLE		 FAST		 SLOW	 SLOW	 SLOW	

* A distinctly different ringback audible can be provided in most cases

FIRST OUT, AUTORESET												
SEQUENCE CODE	ALARM DEVICE	NORMAL	ALERT		ACKNOWLEDGE		RETURN TO NORMAL		RETURN TO NORMAL BEFORE ACK.		ACKNOWLEDGE	
			INITIAL	NEXT	INITIAL	NEXT	INITIAL	NEXT	INITIAL	NEXT	INITIAL	NEXT
F1A	VISUAL											
	AUDIBLE											

FIRST OUT WITH FIRST OUT RESET													
SEQUENCE CODE	ALARM DEVICE	NORMAL	ALERT		ACKNOWLEDGE		RETURN TO NORMAL		RETURN TO NORMAL BEFORE ACK.		ACKNOWLEDGE		RESET
			INITIAL	NEXT	INITIAL	NEXT	INITIAL	NEXT	INITIAL	NEXT	INITIAL	NEXT	
F2M	VISUAL												
	AUDIBLE												

FIRST OUT, MANUAL RESET													
SEQUENCE CODE	ALARM DEVICE	NORMAL	ALERT		ACKNOWLEDGE		RETURN TO NORMAL		RETURN TO NORMAL BEFORE ACK.		ACKNOWLEDGE		RESET
			INITIAL	NEXT	INITIAL	NEXT	INITIAL	NEXT	INITIAL	NEXT	INITIAL	NEXT	
FFAM2 (RIS)	VISUAL												
	AUDIBLE												

FIRST OUT, TRIPLE FLASH, FIRST OUT RESET													
SEQUENCE CODE	ALARM DEVICE	NORMAL	ALERT		ACKNOWLEDGE		RETURN TO NORMAL		RETURN TO NORMAL BEFORE ACK.		ACKNOWLEDGE		FIRST OUT RESET
			INITIAL	NEXT	INITIAL	NEXT	INITIAL	NEXT	INITIAL	NEXT	INITIAL	NEXT	
F3A	VISUAL												
	AUDIBLE												

RINGBACK, DUAL LAMP, DUAL FLASH, MANUAL RESET – 2 WINDOWS PER POINT									
SEQUENCE CODE	ALARM DEVICE	NORMAL	ALERT		ACKNOWLEDG E	RETURN TO NORMAL	RETURN TO NORMAL BEFORE ACK	ACKNOWLEDGE	RESET
			FAST	LAMP 1					
R-12C	VISUAL								
	AUDIBLE								

* A distinctly different ringback audible can be provided in most cases

Dual Lamp sequences use only inputs 1 and 3 on each input card. Inputs 2 and 4 should not be connected.

FIRST OUT, DUAL LAMP, FIRST OUT RESET – 2 WINDOWS PER POINT													
SEQUENCE CODE	ALARM DEVICE	NORMAL	ALERT		ACKNOWLEDGE		RETURN TO NORMAL		RETURN TO NORMAL BEFORE ACK.		ACKNOWLEDGE		FIRST OUT RESET
			INITIAL	NEXT	INITIAL	NEXT	INITIAL	NEXT	INITIAL	NEXT	INITIAL	NEXT	
F3C	VISUAL		SLOW 	SLOW 									
	AUDIBLE												

Dual Lamp sequences use only inputs 1 and 3 on each input card. Inputs 2 and 4 should not be connected.

RINGBACK, DUAL FLASH, LOCK IN UNTIL ACKNOWLEDGED						
SEQUENCE CODE	ALARM DEVICE	NORMAL	ALERT	ACKNOWLEDGE	RETURN TO NORMAL	RESET
R	VISUAL		FAST 		SLOW 	
	AUDIBLE					

















* A distinctly different ringback audible can be provided in most cases

RINGBACK, DUAL LAMP, LOCK IN UNTIL ACKNOWLEDGED – 2 WINDOWS PER POINT						
SEQUENCE CODE	ALARM DEVICE	NORMAL	ALERT	ACKNOWLEDGE	RETURN TO NORMAL	RESET
RC	VISUAL		FAST 		SLOW 	
	AUDIBLE					

* A distinctly different ringback audible can be provided in most cases

Dual Lamp sequences use only inputs 1 and 3 on each input card. Inputs 2 and 4 should not be connected.

FIRST OUT, TRIPLE FLASH, FIRST OUT RESET											
SEQUENCE CODE	ALARM DEVICE	NORMAL	ALERT		ACKNOWLEDGE		RETURN TO NORMAL BEFORE ACK.		RETURN TO NORMAL AND RESET		RETURN TO NORMAL AND RESET RESET
			INITIAL	NEXT	INITIAL	NEXT	INITIAL	NEXT	INITIAL	INITIAL	
F3M	VISUAL		INT. FAST 	FAST 	SLOW 		INT. FAST 	FAST 			
	AUDIBLE										

FIRST OUT WITH FIRST OUT RESET									
SEQUENCE CODE	ALARM DEVICE	NORMAL	ALERT		ACKNOWLEDGE		RETURN TO NORMAL AND ACK.		RETURN TO NORMAL. RESET
			INITIAL	NEXT	INITIAL	RESET	INITIAL	NEXT	
F2A	VISUAL		FAST 		SLOW 	SLOW 			
	AUDIBLE								

For intermixed sequences specify IMO order code

LEGEND

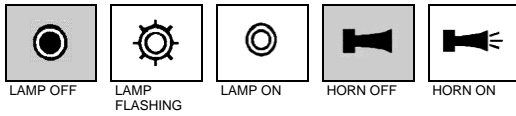

APPENDIX B

MODBUS DATA FORMATS

The AN3200 Modbus operates as a Master or Slave in both Modbus RTU and Modbus TCP/IP modes. The AN3200 Modbus port will transmit the ON/OFF Status (called 'Alarms') and when equipped with the SER option, the timestamp recorded for every alarm and return to normal occurrence (called 'Events').

Alarm ON/OFF Status is provided by reading 16-bit holding registers (Modbus Function 03) with a single bit designated per input. A 48 input system would indicate the status of all alarms using three 16-bit holding registers.

Event Data is provided by reading six 16-bit holding registers (Modbus Function 03) that contain the time, date, input number and alarm status for each event.

An event could be an input going into alarm or returning to normal. Event data is provided in blocks of ten events for a total of sixty 16-bit holding registers. If there are no new events since the last Modbus poll, it will return all FF's. If there are more than 10 events in the buffer, then it will continue to submit 10 events every poll until there are no new events.

The system has the capability of operating with three distinct data formats: point mode, alarm state mode and AN3135 mode. The latter is designed to be compatible with existing AN-3100C Modbus installations. All these formats are embedded within Modbus data registers for transmission and reception.

A selection of Modbus function may be used and these vary depending on the whether the AN-3200 is operating as Modbus master or slave.

Function	Description	Data Units	Data Direction		AN-3200 Supported Mode
			Master	Slave	
3	Read Holding Registers	Words	Input	Output	Master or slave
6	Preset Single Register	Words	Output	Input	Slave only
7	Read Exception Status	Bytes	Input	Output	Slave only
16	Preset Multiple Registers	Words	Output	Input	Master or slave
17	Report Slave ID	Bytes	Input	Output	Slave only

A function value of 03 (Read Holding Registers) is set to read alarm data from the system (in slave configuration). Function values 06 (Preset Single Register) and 16 (Preset Multiple Registers) are used to write fault and control data.

Single and multiple register writes are supported. Exception status responses (function 07) and Slave ID (function 17) are also supported. Exception codes for unrecognized received messages are also included.

The Modbus functions are enabled by a software switch and require a key to enable them, which is supplied by AMETEK. This may be done prior to delivery or retrofitted to installed systems.

Point Mode

The system can present or accept (transmit or receive) raw field input point data plus alarm controls. Single and multiple register writes are supported. Data is again presented in a 16 bit register format. The last word of a transfer of input data may optionally contain control data.

The data layout for a sample system configured for point data will be as below.

Word	Bit15	Bit6	Bit5	Bit4	Bit3	Bit2	Bit1	Bit0
1	AP 16			AP 01
..
15	AP 240			AP 225
16							Ack Rec	Rst Rec	Ack Tran	Rst Tran

AP refers to Alarm Point Channel. ACK refers to the Acknowledge Pushbutton and RST refers to the RESET Pushbutton.

The local pushbutton controls (on the front of the Annunciator and other ones connected to the external pushbutton inputs) can be transmitted (Tran) to a remote device using Ack Tran and Rst Tran as shown. The Annunciator can also receive (Rec) the pushbutton controls from the remote device using Ack Rec and Rst Rec as shown.

AN3135 Mode

The system has the capability of mimicking the existing AN-3100C Modbus functionality. The object is to provide a system that is backwards compatible with the existing AN-3135 Modbus Module used on AN-3100C systems. The AN3135 mode is restricted to the default Functions of 03 to read alarm data and 06 and 16 being used to write fault and control data. The principal difference between this and the point mode above is that the AN3135 mode is restricted to 64 points.

The data layout for a sample system configured for point data will be as below.

Word	Bit15	Bit6	Bit 5	Bit4	Bit3	Bit2	Bit1	Bit0
1	AP 16	AP 01
..
4	AP 64			AP 49
5							Ack Rec	Rst Rec	Ack Tran	Rst Tran

AP refers to Alarm Point Channel. ACK refers to the Acknowledge Pushbutton and RST refers to the RESET Pushbutton.

The local pushbutton controls (on the front of the Annunciator and other ones connected to the external pushbutton inputs) can be transmitted (Tran) to a remote device using Ack Tran and Rst Tran as shown. The Annunciator can also receive (Rec) the pushbutton controls from the remote device using Ack Rec and Rst Rec as shown.

Event Data

Event data may be read in blocks of 10 events at a time. These appear in a block of 60 registers (6 per event) located at the configured Start Address plus 1000 i.e. if the Start Address is set to 40001 then the events appear at 41001-41060. Once ten events are read then the registers are reloaded with any subsequent ones from the 500 event buffer. If no event has occurred, then all 12 bytes are filled with FF HEX.

The event data format is as shown below:

Word	MSB	LSB
1	Year	Month
2	Day	Hour
3	Minute	Second
4	Millisecond (0-999)	
5	0x00	Input Point No.
6	IRIG-B Sync	1 = Point on 0 = Point off

An example of the register format for the 10 events is shown below:

Event Data		
41001	1st Event	Year (0-99) high byte / Month (1-12)low byte
41002		Day of month (1-31)high byte /Hours (0-23) low byte
41003		Minutes (0-59) high byte / Seconds (0-59) low byte
41004		Milliseconds (0-999) two bytes
41005		AN-3200 Point Number (1-198)
41006		IRIG-B Sync – high byte / Point Status (1 = A, 0 = N) low byte
41007	2nd Event	Year (0-99) high byte / Month (1-12)low byte
41008		Day of month (1-31)high byte /Hours (0-23) low byte
41009		Minutes (0-59) high byte / Seconds (0-59) low byte
41010		Milliseconds (0-999) two bytes
41011		AN-3200 Point Number (1-198)
41012		IRIG-B Sync – high byte / Point Status (1 = A, 0 = N) low byte
41054	10th Event	Year (0-99) high byte / Month (1-12)low byte
41056		Day of month (1-31)high byte /Hours (0-23) low byte
41057		Minutes (0-59) high byte / Seconds (0-59) low byte
41058		Milliseconds (0-999) two bytes
41059		AN-3200 Point Number (1-198)
41060		IRIG-B Sync – high byte / Point Status (1 = A, 0 = N) low byte

* Supports Master or Slave Mode, Transmit only

Modbus Addresses

Conventional addresses are included in the configuration. The input and output functions here are the most commonly used and refer to a system in slave configuration.

Conventional Start address	Data	Input Functions	Output Functions
00000	Output Coils	05,15	01
10000	Discrete Inputs		02
30000	Input Registers		04
40000*	Holding (output) Registers	06,16	03
60000	Extended Memory		

*Supported in the AN-3200

Default Values

Designation	Options	Default	Comments
Modbus Address	0-255	01	
Receive Start Address	40001-49999	40001	Register address entry.
Transmit Start Address	40001-49999	40001	
Modbus Mode	Master/Slave	Slave	
Data type	AN3135 /Point/State	Point	An3135 mimic, point or alarm state data.
Baud rate	2400/4800/9600/19200	9600	
Parity	Odd/Even/none	None	Parity type
Transmit controls	Yes/No		Send alarm control (ACK, RST) data
Data direction	Input/output	Output	1 bit per point to designate Tx/Rx data
Modbus format	ASCII/RTU	RTU	

APPENDIX C

DNP DATA FORMATS

The DNP Communication option is used to transmit point status (Binary Inputs) to other devices. When the SER time-stamped alarms option is enabled, a historical record of binary input change events and the time at which they occurred can also be sent. The DNP Communications work in a slave mode and operate over RS-232/485 or Ethernet. The DNP implementation is outlined in the Device Profile Document.

DEVICE PROFILE DOCUMENT

DNP V3.0	
DEVICE PROFILE DOCUMENT	
Vendor Name: AMETEK Power Instruments	
Device Name: AN3200, using the Triangle MicroWorks, Inc. DNP3 Multi-Port Slave Source Code Library	
Highest DNP Level Supported: For Requests: Level 2 For Responses: Level 2	Device Function: Slave
Notable objects, functions, and/or qualifiers supported in addition to the Highest DNP Levels Supported (the complete list is described in the attached table): For static (non-change-event) object requests, request qualifier codes 00 and 01 (start-stop), and 17 and 28 (index) are supported in addition to request qualifier code 06 (no range – or all points). Static object requests received with qualifiers 00, 01 or 06, will be responded to with qualifiers 00 or 01. Static object requests received with qualifiers 17 or 28 will be responded to with qualifiers 17 or 28. For change-event object requests, qualifier codes 06 (no range) and 07 and 08 (limited quantity) are supported. Qualifiers 17 or 28 are always returned.	
Maximum Data Link Frame Size (octets): Transmitted: 292 Received 292	Maximum Application Fragment Size (octets): Transmitted: 170 Received 50
Maximum Data Link Re-tries: Configurable from 0 to 255	Maximum Application Layer Re-tries: None
Requires Data Link Layer Confirmation: Configurable as: Never, Only for multi-frame messages, or Always	
Requires Application Layer Confirmation: When sending multi-fragment responses (Slave devices only) Sometimes	

DNP V3.0

DEVICE PROFILE DOCUMENT

Timeouts while waiting for:

Data Link Confirm: **Configurable.**
 Complete Appl. Fragment: **None**
 Application Confirm: **Configurable.**
 Complete Appl. Response: **None**

Others: **Transmission Delay, configurable**

Inter-character Timeout, 1 second

Need Time Delay, configurable

Frozen Counter Change Event Scan Period, Fixed at 1 second

Sends/Executes Control Operations:

WRITE Binary Outputs **Never**
 SELECT/OPERATE **Never**
 DIRECT OPERATE **Never**
 DIRECT OPERATE – NO ACK **Never**
 Count > 1 **Never**
 Pulse On **Never**
 Pulse Off **Never**
 Latch On **Never**
 Latch Off **Never**
 Queue **Never**
 Clear Queue **Never**

Reports Binary Input Change Events when no specific variation requested:
Never

Reports time-tagged Binary Input Change Events when no specific variation requested:
Never

Sends Unsolicited Responses:
Never

Sends Static Data in Unsolicited Responses:
Never
 No other options are permitted.

Default Counter Object/Variation:
 fault Object 1
 fault Variation: 1

Counters Roll Over at:
No Counters Reported

Yes

IMPLEMENTATION TABLE

OBJECT			REQUEST	RESPONSE	
Object Number	Variation Number	Description	Function Codes (decimal)	Function Codes (decimal)	Qualifier Codes (hex)
1	1	Binary Input	1 (read)	129 (response)	00, 01 (start-stop)

PUSHBUTTON CONTROLS

Pushbutton activation can be transmitted from the Annunciator via a Binary input to indicate whenever a pushbutton is activated locally at the Annunciator. (Reference the Binary Input Data Map for location of the pushbutton indications.)

Pushbutton controls can be sent to the Annunciator using a Control Relay Output block, as detailed below.

Control Relay Output Block (Object 12, variation 2)

Index #	DNP Object		Control Code	Description
	Object Number	Variation Number		
00	10	02	LON, LOFF *	Reset Pushbutton
01	10	02	LON, LOFF *	Acknowledge Pushbutton
For proper pushbutton operation, transmit a single LON (latch on) followed by a single LOFF (latch off). Allow a few seconds in between commands to ensure the Annunciator receives the pushbutton controls.				
Mode: Direct 16 Bit Index				

The Pushbutton Control Status can be checked by issuing a Binary Output Status, Object 10, variation 2.

Binary Output Status (Object 10, Variation 2)

Index #	DNP Object		Description
	Object Number	Variation Number	
00	10	02	Reset Pushbutton
01	10	02	Acknowledge Pushbutton

AN-3200 DATA MAP

Binary Inputs

The Annunciator alarms are presented as binary inputs as shown below.

Index #	DNP Object		Description
	Object Number	Variation Number	
00	01	00	Point 1 Digital Contact Alarm
01	01	00	Point 2 Digital Contact Alarm
02	01	00	Point 3 Digital Contact Alarm
03	01	00	Point 4 Digital Contact Alarm
04	01	00	Point 5 Digital Contact Alarm
05	01	00	Point 6 Digital Contact Alarm
06	01	00	Point 7 Digital Contact Alarm
07	01	00	Point 8 Digital Contact Alarm
08	01	00	Point 9 Digital Contact Alarm
09	01	00	Point 10 Digital Contact Alarm
10	01	00	Point 11 Digital Contact Alarm
196	01	00	Point 197 Digital Contact Alarm
197	01	00	Point 198 Digital Contact Alarm
198	01	00	Point 199 Digital Contact Alarm
199	01	00	Point 200 Digital Contact Alarm
200	01	00	Acknowledge Pushbutton
201	01	00	Reset Pushbutton

Binary Input Change with Time (SER Option)

The time stamped alarms are presented as Binary Input Changes with Time when the SER Option is provided.

DNP Object		Description
Object Number	Variation Number	
02	02	Digital Contact Alarm w/time of event

APPENDIX E

WEB OPTION

The AN-3200 has a built-in WEB server that can be used with your Web browser client such as Internet Explorer or Firefox for displaying your alarms and unit configuration. Refer to Appendix G for compatibility requirements and browser configuration.

Launch your browser and type in your unit's IP address. The AN-3200 is shipped with a default address of: `http://192.168.250.100`

A User ID/Password dialog box will pop up as shown in Figure E–1.

The AN-3200 has two levels for access and can be configured as shown, later in this chapter. The default username is: admin with password: admin and user: user. The unit's home page will be displayed where you can view and access all the features of the unit, depending on your user account rights.

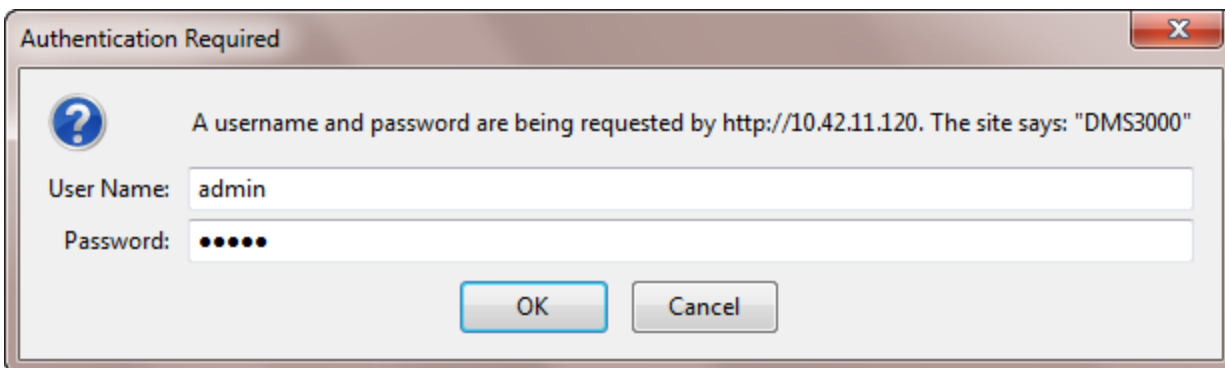

Figure E–1. AN-3200 Login Dialog Box

Note: Your system or network administrator must set up the user accounts. There are two basic types, Admin and User. An Administrator account has full rights and can change anything. The User account has limited rights and cannot change passwords, apply or discard changes. Some action buttons will be grayed out under a User account.

The WEB option provides the ability to see alarms and events with timestamps via the WEB Browser display. The WEB Browser display option provides an Active Alarm page and an Event Log page.

Active Alarms

This web page will display any inputs that are currently in the Alarm State. The alarms are displayed in chronological order and can be color coded to differentiate alarms that have been acknowledged or returned to normal. New alarms are automatically updated on this page as they occur. Alarms include their data and time stamp, station ID, device ID, input number and pre-configured alarm legend.

The web display also includes an Acknowledge Pushbutton so operators can respond to alarms remotely. There is a selection for latching alarms in case you want them to remain on this display when they clear until they are acknowledged. Otherwise, they will clear from this display when the alarm returns to normal.

Event Log

This web page is used to view all alarms, past and present , up to 1000 events max. It displays the date and timestamp when the inputs went into alarm and returned to normal. It also logs any diagnostic events and monitors the external time synchronization status. The alarms are presented in chronological order, but can be sorted by any field: date and time, event type, station ID, device ID, input number. It will store a maximum of 40,000 events.

In addition, the event log can be filtered to display events in a specific time frame, type of events or specific alarm inputs so you can create a custom report detailing the information you need. You can then download the events into a csv file and send them to a printer on your network.

AN-3200 HOME PAGE

Figure E-2 shows the home page with administrator logged in. The top bar of the home page displays the current date/time (in UTC and local time), and number of Active Alarms. The check box – *Enable 30 second auto-refresh*, when checked, will refresh the top portion of the page (blue box) every 30 seconds.

The web browser home page has a graphic display of the AN-3200 that matches the system configuration of the Annunciator. Figure E-2 below shows an AN-3200 Annunciator system with 2 rows high by 4 columns wide and 4 different window sizes. The home page Annunciator graphic will follow the A (Automatic Reset) or M (Manual Reset) operating sequence depending on which sequence is selected on the Annunciator. (If the sequence on the Annunciator is not A or M, it will default to M.) AN-3200 inputs configured as critical or non-critical alarms (via the Annunciator Configuration Software) can each have their own unique color to indicate alarm, normal or acknowledged states. Figure E-2 below shows critical alarm input #3 in the alarm state. There are Acknowledge and Reset pushbuttons provided on the home page for acknowledging the web page windows. Inputs that have been disabled will have a user selectable color background to highlight the disabled state.

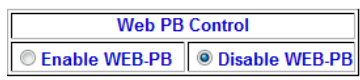
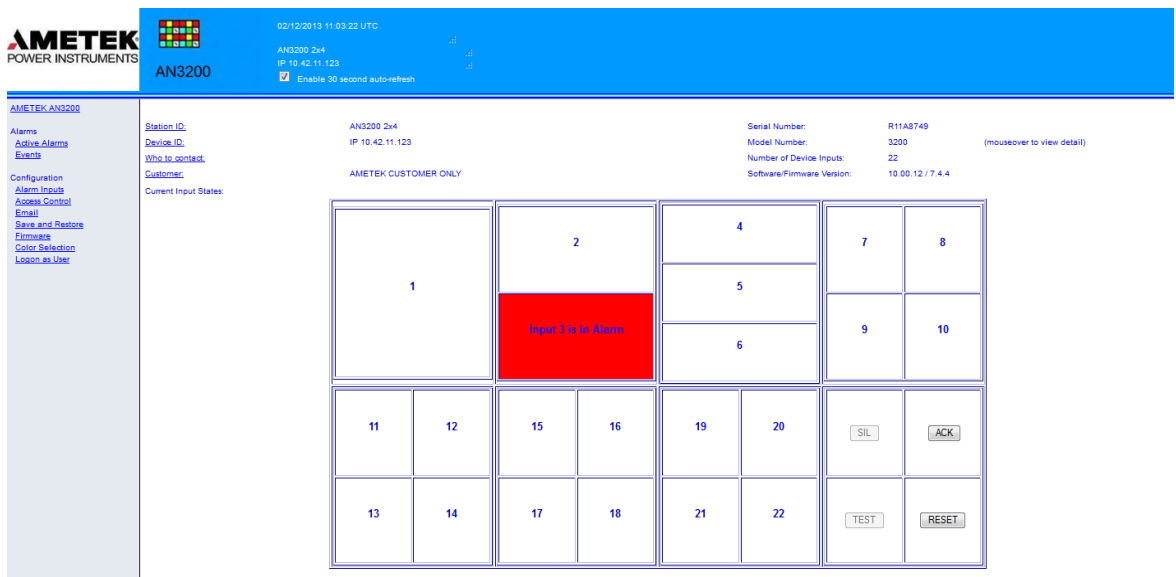

This determines whether the WEB Pushbuttons control the AN-3200 Annunciator.

- Critical Active Alarms
- NonCritical Active Alarms
- Acknowledged Alarms

Figure E-2. AN-3200 Home page

WEB PB Control

The pushbuttons on the home page will be shown in the lower right cell if AN-3200 option INTB is selected. If options NPB or LPPB are selected, the pushbuttons will be shown underneath the Annunciator. There is a selection box to allow the web pushbuttons to control the AN-3200 windows

(Enable WEB-PB) or have the web pushbuttons only control the web page (Disable WEB-PB). In all cases, the pushbuttons pressed on the Annunciator itself or wired to the rear terminals will control the web page as well.

Home Page Editable Fields

In this section, please refer to the links directly below the top bar. The items on the right, *Serial Number*, *Number of Device Inputs* and *Software/Firmware Version*, are configured at the factory.

Links that you can edit are underlined, such as: *Station ID*, *Device ID*, *Who to contact*, *Customer*. When you click on a link in this section, a small dialog box will appear where you can enter the appropriate information (see Fig. E-3). After typing in a name, for instance, you simply click the save button. All editable fields, i.e. Station ID, may contain up to 32 alphanumeric characters.

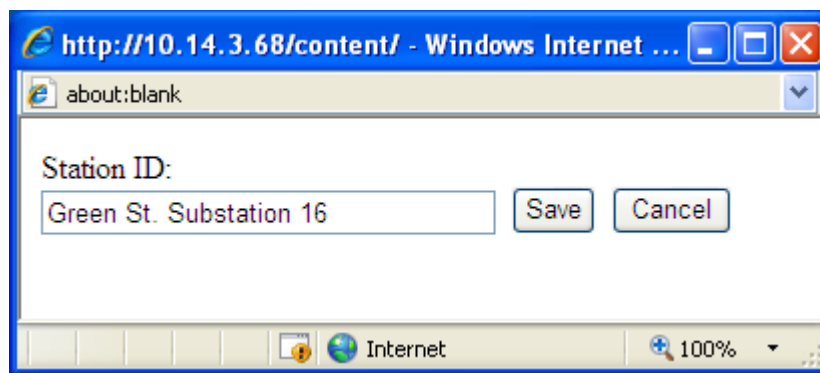

Figure E-3. Pop-up Dialog Box

Station ID

Click this link to enter a specific location name for the unit. i.e. Green St. Substation 16. This name will be reported in the Active Alarms and Events list, event download, ASCII output and printouts.

Device ID

This name is more specific, i.e. to identify a single unit in a substation containing many units. It should be used to identify a AN-3200 unit or group of alarms connected to the unit. i.e. AN-3200 Device 1 or Breaker XYZ. The device ID will be reported in the Alarms and Events list, event download, ASCII output and printouts.

Who to Contact

This field is used to identify a contact such as in case of emergency.

Customer

Here is where you enter the customer's name.

WEB Browser Navigation

The side-bar on the home page contains links to all of the pages for unit access and configuration. The **AMETEK AN3200** link on the top always redirects you to the Home Page shown in Figure E-4, similarly to when Refresh is performed on the Browser.

The side-bar is separated into two Categories: Alarms and Configuration. The links under 'Alarms' allow you to view active or historical alarms. The links under 'Configuration' are used for configuring the AN-3200 unit.

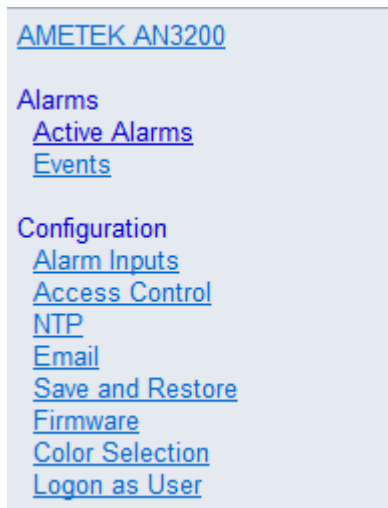

Figure E-4 AN-3200 Navigation Sidebar.

ACTIVE ALARMS PAGE

The Active Alarm screen is used as a 'heads-up display' for identifying all inputs that are currently in the alarm state along with a timestamp. When equipped with the CR option, the Master AN-3200 will display alarms from itself as well as every slave AN-3200 connected to it, in chronological order.

Active Alarms

[Acknowledge Alarms](#)

This page displays a list of all active alarms.

Alarms are color coded as follows: **New Alarms**, **Acknowledged Alarms**, & **Latched Alarms**. A "Latched Acknowledged", it will clear from this page.

Alarms that return to normal will clear from this page and will be available for viewing in the event log.

Note: the full alarm history is currently available in the [Event Log](#).

Latched Alarms

Date	Time	Station ID	Device ID	Point	Alarm Description
05/11/2031	17:19:29.015	Bruce Pt Substation	230kV Alarms	194	Input 2 is in Alarm
05/11/2031	17:19:29.015	Bruce Pt Substation	230kV Alarms	199	Input 7 is in Alarm
05/11/2031	17:19:29.015	Bruce Pt Substation	230kV Alarms	206	Input 14 is in Alarm
05/11/2031	17:19:29.015	Bruce Pt Substation	230kV Alarms	213	Input 21 is in Alarm
05/11/2031	17:19:29.015	Bruce Pt Substation	230kV Alarms	231	Input 39 is in Alarm
12/11/2012	15:42:04.015	Black River Generation	Turbine Alarms	73	Input 73 is in Alarm
12/11/2012	15:48:02.015	Black River Generation	Turbine Alarms	5	Input 5 is in Alarm
12/11/2012	15:48:02.015	Black River Generation	Turbine Alarms	16	Input 16 is in Alarm
12/11/2012	15:48:02.015	Black River Generation	Turbine Alarms	38	Input 38 is in Alarm
05/11/2031	17:19:29.015	Bruce Pt Substation	230kV Alarms	198	Input 6 is in Alarm
05/11/2031	17:19:29.015	Bruce Pt Substation	230kV Alarms	216	Input 24 is in Alarm

Figure E-5. Active Alarms (#)

As shown in figure E-5, the Active Alarm page displays all active alarms in chronological order as they occur. The active alarms can be latched by selecting the 'latched alarms' box or unlatched. The alarms can be color coded to show the various alarm states: Alarm, Acknowledged and Normal.

In Figure E-5, Alarms are shown in Red, latched alarms that returned to normal before they were acknowledged are shown in Black and active alarms that have been acknowledged are shown in green. Different colors can be selected in the color selection configuration screen.

The selection box for Latched Alarms allows you to latch alarms on this web page until they have been acknowledged. Unlatched alarms will disappear from this web page as soon as they return to normal. In all cases, the alarms are stored in memory after they clear for future analysis and viewing on the Event Log.

EVENT LOG PAGE

The Event log is used to view, sort, filter, print and download all alarms in memory. Each AN-3200 Logic Card Rack can store up to 40,000 events. An event can be an input going into alarm, returning to normal, diagnostic message and time synchronization status.

The event log is used to perform alarm management by filtering the list to a specific date and timeframe, sorting them by chronological order to determine the exact sequence of events for root cause analysis. In addition, events can be filtered to a specific input number or group of numbers to trend the number of occurrences within a given time frame. The event log can be downloaded for further analysis and data manipulation.

The Event Log displays all active and archived alarms, system status and diagnostics. In addition, the Event Log provides various sorting and filtering options and the ability to download or print events.

AMETEK POWER INSTRUMENTS

AN3200

02/12/2013 11:05:19 UTC

AN3200 2x4
IP 10.42.11.123
 Enable 30 second auto-refresh

AMETEK AN3200

Alarms
Active Alarms
Events

Configuration
Alarm Inputs
Access Control
Email
Save and Restore
Firmware
Color Selection
Logon as User

Event Log The event log contains a history of the events recorded by Annunciator. Maximum events to retrieve: 1000

Download File (.csv) Erase the log Print Events Free space: 100.0%

Filter events by: Date & Time Descriptor Point Number(s) Clear Filters Click to refresh

Date v	Time v	Descriptor	Station ID	Device ID	Point	Event Description
02/07/2013	06:23:51.352	D	AN3200 2x4	IP 10.42.11.123		Power Restored / Reboot Complete
02/07/2013	06:23:51.352	D	AN3200 2x4	IP 10.42.11.123		Power Loss / Reboot
02/04/2013	08:36:38.619	D	AN3200 2x4	IP 10.42.11.123		Communications Restored with Main Board
01/28/2013	19:13:06.956	N	AN3200 2x4	IP 10.42.11.123	3	Input 3 has returned to Normal
01/28/2013	19:13:06.955	A	AN3200 2x4	IP 10.42.11.123	2	Input 2 is in Alarm
01/28/2013	19:12:47.700	N	AN3200 2x4	IP 10.42.11.123	2	Input 2 has returned to Normal
01/28/2013	19:12:47.699	A	AN3200 2x4	IP 10.42.11.123	3	Input 3 is in Alarm
01/28/2013	19:10:17.780	N	AN3200 2x4	IP 10.42.11.123	3	Input 3 has returned to Normal
01/28/2013	19:10:17.779	A	AN3200 2x4	IP 10.42.11.123	2	Input 2 is in Alarm
01/28/2013	19:09:53.459	N	AN3200 2x4	IP 10.42.11.123	10	Input 10 has returned to Normal
01/28/2013	19:09:53.459	N	AN3200 2x4	IP 10.42.11.123	9	Input 9 has returned to Normal
01/28/2013	19:09:53.459	N	AN3200 2x4	IP 10.42.11.123	8	Input 8 has returned to Normal

Figure E-6. Event Log, Filtered to show Alarm Events only

Event Descriptor

The Event Log format consists of a Date and Time of the event, a Descriptor that identifies the type of event, the Station ID and Device ID identifying where the Alarm came from, Point Number for the alarm and Event Description which is configured for every input. Any of these fields can be sorted by selecting the field description. Selecting it again will do a reverse sort.

The different types of events are identified with a descriptor as shown in the table below.

Event Types	Event Descriptor	Event Description
Alarm Event	A N	Input goes into the Alarm State Input Returns to Normal State
Diagnostic Event	D	System Diagnostic for: -Unit Configuration -Disabled Alarms (Manual or Automatically) -Acknowledged Alarms -System Watchdog Faults <i>Refer to Appendix I for a complete list of diagnostic events</i>
Time Event	T	Event associated with Time Clock -Time Sync enabled -Time sync lost -Time Reset

At the top of the Event Log WEB page you will find buttons for downloading to a .csv file, erasing and printing the log and setting the filters. The options are described below.

Download File (.csv)

If you want to save a copy of the events log to your pc, click the 'Download File (.csv) button. You may see a yellow warning bar across the top of the window. If so, follow the steps in Appendix G to configure your browser. If not, you will be prompted with a Script Prompt asking you if you want to download all events. Answering *Yes* will download all events, *No* will download only the events in view (with filters applied). Next you'll be prompted with the dialog box (Fig. E-7) to open or save this file. Either open the file to view it, or select a folder where to save it. If you open the file, typically MS Excel® will open displaying the events in tabular form. From Excel® you can print the file in that form. Printing with the "Print Events" button will print the list as seen in the browser.

Note: There is a maximum of 1,000 events that you can view through the browser. To obtain a copy of all events (up to 40,000), you must answer *yes* after you click the *Download File* button.

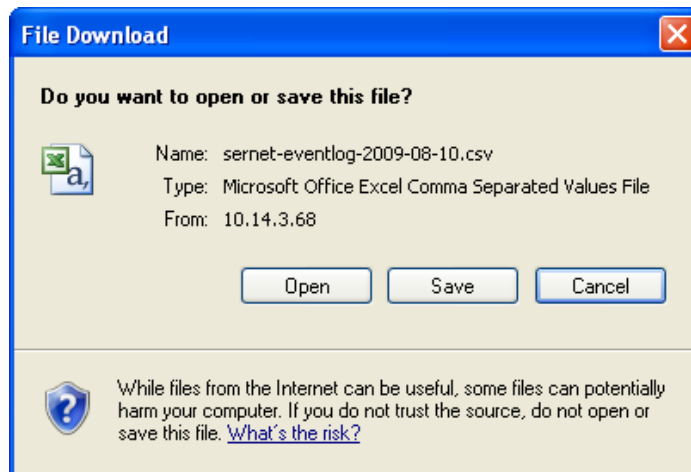

Figure E-7. Save .csv File Dialog Box

Erase the log (only for administrators)

Use caution, as this will permanently wipe out all events in the log. Under a User login, this option is grayed out. The event buffer stores a maximum of 40,000 events in non-volatile RAM. Events are automatically deleted on a FIFO basis (First In, First Out).

Print Events

Click here to create a printout of the events in the current view. It will print as viewed on the web page.

Maximum events to retrieve

The AN-3200 Event Buffer can store 40,000 events. The number of events displayed at any one time can be selected by entering the number in this text box, (top right), followed by clicking the  icon to refresh the page with the desired number of events. A range of 1 – 1000 of the most recent events are allowed in this entry. Depending on how you sort and filter the list of events, it could be the most recent group of events or oldest alarms stored in memory.

Event Sorting and Filtering

Event Sorting

The column headings are active elements, meaning you can click on the column heading to change the sorted order of the events. It works similar to the column headings in Windows explorer. An arrow will appear, next to the heading title, toggling up and down each time you click the heading. For example, each time you click the Date column heading, the events are resorted chronologically or in reverse. Depending on the number of events, this could take a few seconds to change.

Filter Events by:

The Event Log can be filtered to only show alarms within a given date and time, specific event types and specific inputs.

You can combine 2 filters at one time to obtain an even more selective set. The following combinations of filters can be entered:

- Date & Time and Descriptor
- Date & Time and Point Number

When a filter is active, the filter criteria are displayed above the events table.

Date & Time Filter

To set date/time filters, click the Date & Time button on the page. This brings up the dialog box shown in the following figure. The events will be displayed according to your selection criteria. The default entry shows the current Date/Time range of the events currently in view.

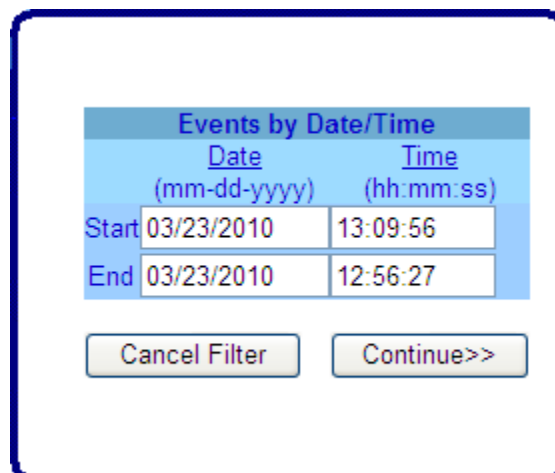

Events by Date/Time	
Date (mm-dd-yyyy)	Time (hh:mm:ss)
Start 03/23/2010	13:09:56
End 03/23/2010	12:56:27

Cancel Filter Continue>>

Figure E-8. Date/Time Filter Dialog Box

Descriptor Filter:

In this dialog box you can set what descriptors you want to display in the event log. Multiple descriptors may be selected. Place a check in the appropriate check box to enable that option. Please refer to the following figure.

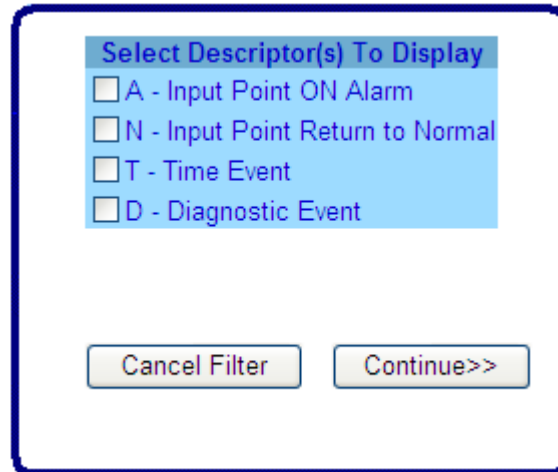

Figure E-9 Descriptor Dialog Box

Point Number(s) Filter:

Here you can set which points you want displayed in the events list. Multiple points may be selected by using a comma between input numbers.



Figure E-10. Points Dialog Box

The *Clear Filters* button will remove the event filters that you configured and displays the latest events.

ACCESS CONTROL CONFIGURATION

Access control is available to Administrators only. As shown in the following figure, the AN-3200 is equipped with built-in security to prevent unauthorized access to network configuration parameters, firmware upgrades and other critical settings. This page is where the system administrator sets up user passwords and network configuration such as SNMP and Modbus access and port numbers. As with most password fields, you will only see asterisks as you type in your password.

User and Admin authority are detailed below (respectively):

User Account can:

- View Active Alarms
- View Event Logs
- View Configuration Details
- Sort and Filter Events for viewing purposes
- Export events via csv download
- Print events

Admin Account can:

- Include all of the 'User' functions above
- Change configuration details (anything with an 'Apply' button)
- Set time and date
- Acknowledge Alarms
- Erase the Event Log
- Enable or Disable an alarm
- Change Passwords
- Save and Restore Configuration
- Firmware Upgrade
- Option Upgrade

Trusted IPs/hostnames

To add another level of security to your network, select the appropriate checkboxes if you wish to restrict IP/hostnames for either SNMP or Modbus. Once checked, the traffic to the port will be restricted, allowing access to only those addresses/hostnames that you entered into the trusted field. This works like a firewall. You enter a semi-colon separated list of addresses or hostnames into the trusted field.

Ports

You can enter specific Ethernet Port Addresses for Modbus TCP/IP, DNP, WEB Browser (HTTP & HTTPS)

HTTPS

HTTPS requires users to select the secure web log on. You need to identify the specific port address used for this secure connection.

Note: When HTTPS is enabled, you must precede the web browser url address by HTTPS://IP Address, instead of HTTP://IP Address.

Access Control Configuration

This page may be used to change various security related configuration items on Annunciator. To save the changes, click / the values stored in Annunciator.

Note: The passwords are write-only and only updated when not blank.

		Re-type password
Password for the user account	<input type="password"/>	<input type="password"/>
Password for the admin account	<input type="password"/>	<input type="password"/>
Trusted IPs/hostnames (semi-colon separated list)	<input type="text"/>	
SNMP access restricted by IP/hostname	<input type="checkbox"/>	
Modbus TCP access restricted by IP/hostname	<input type="checkbox"/>	
Modbus TCP port	<input type="text" value="502"/>	
DNP TCP access restricted by IP/hostname	<input type="checkbox"/>	
DNP TCP port	<input type="text" value="20000"/>	
HTTP port	<input type="text" value="80"/>	
HTTPS port	<input type="text" value="443"/>	
Require HTTPS	<input type="checkbox"/>	

Figure E-11 Access Control Configuration Page

NTP OPTION

The AN3200 has three possible methods for maintaining system time. The three methods (in order of accuracy) are IRIG-B, Network Time Protocol (NTP), and on-board crystal. If IRIG-B and NTP are not available, then the AN3200 will default to using the on-board crystal. If the Ethernet, Web, and NTP options are installed and the AN3200 is connected to a network, then NTP can be utilized. The Ethernet settings must be configured properly with the Configurator software before the AN3200 can locate an NTP server on the network. Additionally, the IP address of the NTP server must be specified on the NTP Configuration page as shown below. Up to three different NTP servers can be specified. Enter the IP addresses and click on Apply to save the settings.

NTP Configuration

This page may be used to change the NTP configuration of Annunciator. To save the changes, click Apply. Click Discard to cancel any unsaved changes and revert to the values stored. Note: after applying a change, you'll need to refresh the page (e.g. F5) to update the "local" date/time display in the page header.

IRIG-B Time Source Status: (IRIG-B signal NOT detected)

NTP Status: (Synchronized to 10.42.0.150, NTP stratum 1)

NTP server IP/hostname #1
NTP server IP/hostname #2
NTP server IP/hostname #3

Figure E-12 NTP Configuration Page

EMAIL OPTION

The AN-3200 can transmit any alarm to three separate email recipients. All alarms or specific ones can be used to trigger an email. The alarm email will include the input number, time and date of alarm and the alarm legend configured in the unit. The frequency of emails can be configured to send them out as soon as an alarm occurs or batch them up at specified intervals.

The SMTP Server IP address or host name needs to be entered based on whatever email system you are using. You must include your username and password that is used for this system. Consult your IT administrator if unsure of the settings. After configuring the SMTP selections, you can test the settings by pressing the 'Test SMTP Server Connection'. If the SMTP Server address is not recognized, it will provide an error message when you try to save the Email settings.

Enter the recipient email address and select which alarms will trigger the email notification. The frequency of how often the emails will be sent can be configured as '0' which is immediately after an alarm or in hourly increments from 1 to 24. When a selection of 1-24 is used, any alarms that occurred in that interval will be included in the email. Selecting 'Active Alarms' will only provide alarm inputs that are in the alarm state at the time the email is generated. Selecting 'All Events' will include Active Alarms and Alarms that returned to Normal.

Email Configuration

This page may be used to change the email configuration for Annunciator. Configuration for three different recipients can be set. The 'Test SMTP Server Connection' button will cancel any unsaved changes and revert to the values stored in Annunciator. Enter a value of 0, if you wish the email to be sent as events occur or at a configured hourly interval. Use the test button to verify the SAVED SMTP settings.

SMTP server IP/hostname

SMTP username

SMTP password

SMTP "From" address

Recipient-1 Email Frequency

Recipient-2 Email Frequency

Recipient-3 Email Frequency

Recipient - 1	Recipient - 2	Recipient - 3	Alarm Inputs	Normal Legend
<input type="checkbox"/>	<input type="checkbox"/>	<input type="checkbox"/>	1	Input 1 is in Alarm
<input type="checkbox"/>	<input type="checkbox"/>	<input type="checkbox"/>	2	Input 2 is in Alarm
<input type="checkbox"/>	<input type="checkbox"/>	<input type="checkbox"/>	3	Input 3 is in Alarm
<input type="checkbox"/>	<input type="checkbox"/>	<input type="checkbox"/>	4	Input 4 is in Alarm

Figure E-13 Email Configuration Page

ALARM INPUTS

On the Alarm Inputs page, customized alarm legends can be specified for each Alarm Input. The specified Alarm Legend will be listed in the Events Log when the associated input point goes into the Alarm state. The specified Normal Legend will be listed in the Events Log when the associated input point returns to the Normal state. Enter legends for each Input point, and click on the *Apply* button to save.

Alarm Inputs Configuration

This page may be used to change the Legends of the individual Inputs. To save the changes, click Apply. Click Discard to cancel any unsaved changes and revert to the values stored in AN3200.

Input	Alarm Legend	Normal Legend
1	Input 1 is in Alarm	Input 1 has returned to Normal
2	Input 2 is in Alarm	Input 2 has returned to Normal
3	Input 3 is in Alarm	Input 3 has returned to Normal
4	Input 4 is in Alarm	Input 4 has returned to Normal
5	Input 5 is in Alarm	Input 5 has returned to Normal
6	Input 6 is in Alarm	Input 6 has returned to Normal
7	Input 7 is in Alarm	Input 7 has returned to Normal
8	Input 8 is in Alarm	Input 8 has returned to Normal
9	Input 9 is in Alarm	Input 9 has returned to Normal
10	Input 10 is in Alarm	Input 10 has returned to Normal
11	Input 11 is in Alarm	Input 11 has returned to Normal
12	Input 12 is in Alarm	Input 12 has returned to Normal
13	Input 13 is in Alarm	Input 13 has returned to Normal
14	Input 14 is in Alarm	Input 14 has returned to Normal
15	Input 15 is in Alarm	Input 15 has returned to Normal

Figure E-14 Alarm Inputs Configuration Page

SAVE AND RESTORE CONFIGURATION

Available to Administrator only, this page provides a way for you to save the unit's configuration to an XML file. The advantage to this is if for whatever reason you need to reload the AN-3200 configuration at a later date, you'll have the configuration file saved already. Simply browse to the file on your PC and restore the configuration file to the unit.

Note: it is strongly advised to have a copy of each AN-3200 configuration file saved at all times. After you make changes, save a new copy by clicking on the *Save Configuration* button.

To restore a configuration (refer to Figure E-13):

Click the *Browse* button.

From the choose file dialog, select the configuration file to be downloaded to AN-3200.

Click Open and a message box will pop up asking you to confirm your action. Click Ok.

Your AN-3200 unit will be re-configured with the saved file, including all Alarm Inputs and Outputs.

Save and Restore Configuration

This page may be used to save and restore all the configuration items
time, the configuration items can be restored, replacing the current ite

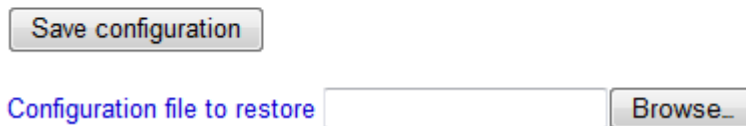

The screenshot shows a web interface for saving and restoring configuration. It features a 'Save configuration' button, a text input field labeled 'Configuration file to restore', and a 'Browse...' button.

Figure E-15 Save and Restore Configuration Page

FIRMWARE CONFIGURATION

The current version number of Software/Firmware installed on your unit is provided on the AN-3200 Home Page.

Station ID:	AN3200 (2x4) Intermixed - Ametek	Serial Number:	R11A8749
Device ID:	IP 10.42.11.123	Model Number:	3200
Who to contact:	AN3200 Project Mgr(12345667890)	Number of Device Inputs:	22
Customer:	AMETEK/Test Unit #1 Annunciator	Software/Firmware Version:	10.00.12 / 7.4.5
Current Input States:			

If a new version of the AN-3200 firmware is available, you can flash it to the AN-3200 using the 'Firmware Configuration' page.

Before starting the process of upgrading the firmware in your unit; save a copy of the AN-3200 configuration using the 'Save and Restore' function as the upgrade process will restore some settings back to the defaults depending on the changes made.

After the firmware is upgraded, you will be prompted to re-boot the AN-3200. This can be done automatically by selecting the checkbox 'Reboot when complete' before you start the upgrade process.

Current Annunciator firmware version: 10.00.12

Reboot when complete

Firmware file to upload to Annunciator

To upgrade the firmware, simply browse for the file on your PC and after you choose the new file, it will begin uploading after your confirmation.

Caution: during a firmware update, do not close the browser window or power down the unit. Doing so will cancel the upload process and corrupt the firmware.

As seen in Figure E-15, during the firmware update process, the file status progress bar will indicate the status of the update.

Green status (Finished or No Update) – update successful.

Yellow status – potential red status event with one of the module updates, or the main board download may have exceeded the 5 minutes allotted to its download. Either way, it's more of an alert than necessarily an error for that particular update.

Red status (File Error, or Hardware Error) – may be one of the following:

- the file that you were trying to download is not correct
- the file could be corrupted
- there was a hardware problem in attempting to erase, or write to the flash

Any status other than green should be reported to AMETEK Factory Support.

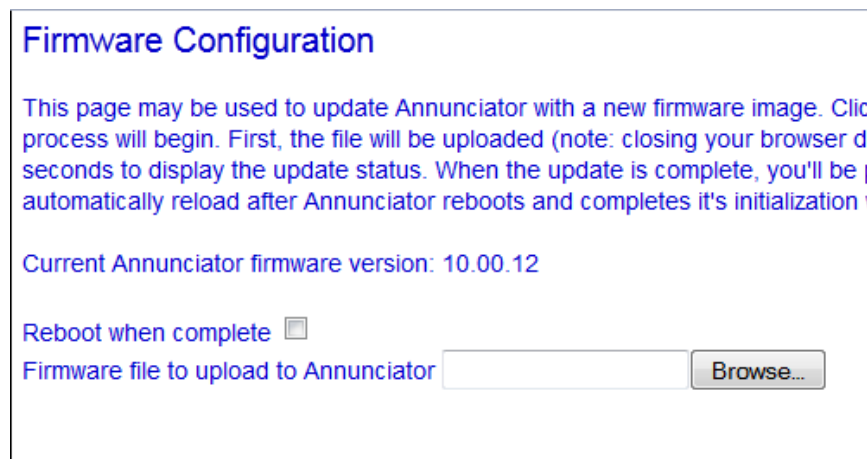

Figure E-16 Firmware Configuration Page

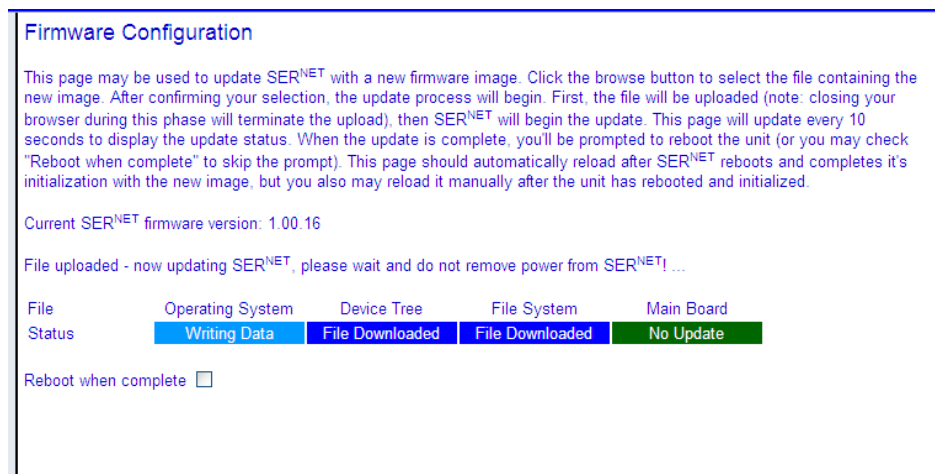

Figure E-17 Firmware Configuration Page After Update

COLOR SELECTION

The AN-3200 can display alarms in several graphical formats which can be selected in the color configuration screen. The Home Page, Active Alarm and Event pages can be color coded for the background and text colors of various events. The configuration page will show the current color selection and provide new selections for background and text colors as applicable.

Color Selection Configuration

This page is used to configure the color preferences for alarms, events and other display items. To save the changes, click Apply. Click Discard to the values stored in Annunciator. To revert all colors to the default values click "Apply Default Colors".

Home Page (cell colors)	Current Colors	New Text Color	New Background Color
Non Critical Alarmed	Sample Non Critical Alarmed	Black	Green
Critical Alarmed	Sample Critical Alarmed	Blue	Red
Acknowledged	Sample Acknowledged	Blue	Yellow
Normal	Sample Normal	Blue	White
Active Alarms Page (text colors)			
Non Critical Alarmed	NonCritical Alarmed	Blue	
Critical Alarmed	Critical Alarmed	Red	
Acknowledged	Acknowledged Alarm	Green	
Latched	Latched and Not Acknowledged	Black	
Events Page (text colors)			
Non Critical Alarms	NonCritical Alarms	Black	
Critical Alarms	Critical Alarms	Red	
Return to Normal	Return to Normal Event	Blue	

Figure E-18 Color Selection Page

LOGON AS USER

To switch logon type click this link. If you are logged in as User, it will display *Logon as Admin* and vice versa. Remember, User logon is restricted. You will be prompted with a logon dialog box as shown in Figure E-1.

DOCUMENTATION

At the bottom of the side-bar you'll find links to the Ametek Power Instruments Web site and the User Guide in pdf format.

APPENDIX F

WINDOW ASSEMBLY DETAILS

The Annunciator uses a common window assembly for all window configurations. The different window options are created using dividers (for the 4 window sizes) and colored filters for the different window colors (white, red, blue, green, amber, yellow). The assembly drawings on the next page identify the different options available.

A typical window consists of the following parts:

- Transparency film with Legends
- Colored Filter if required (red, blue, green, amber, yellow)
- White Diffusers (to eliminate LED hotspots)

All of these parts are pressed into the clear window, which is inserted into the window frame.

Window Legends

The Annunciator Window Legends are typically printed on clear transparency film, which is provided with the Annunciator. There is an option to engrave these legends directly on the window (Option E). For printing of legends on the transparency film, the Software CD will include a template in Microsoft Excel. You type the legend in the window template that matches your size window and print on a suitable printer. (A laser printer is recommended or any type that is compatible with printing on Transparency film.)

Window Colors

The Annunciator Window Colors are provided through colored filters, which are provided with the Annunciator. In cases where several different window colors are required for an individual Cell (option IMC), the laser printed transparency will be colored in place of the color filters. In these cases, color Laser Printer should be used.

Note: All legends and pre-printed colors will be provided with the Annunciator if the details are provided before the unit ships.

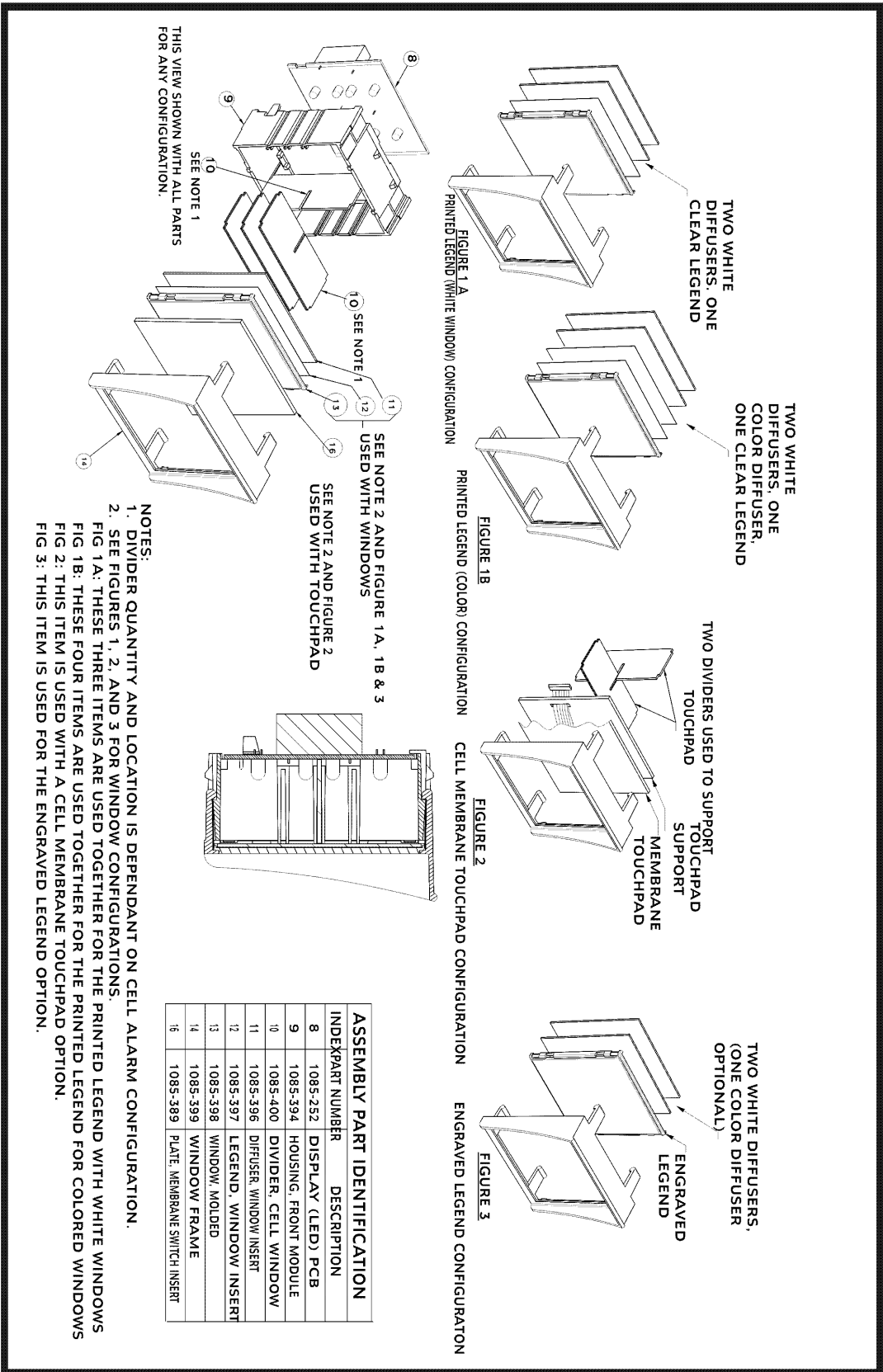

Window Assembly

APPENDIX G BROWSER COMPATIBILITY

If using Internet Explorer you must disable the caching of web pages.

To disable caching with Microsoft Internet Explorer V7

- 1 Choose **Internet Options** from the **Tools** menu. The Internet Options window opens.
- 2 On the **General** tab, in the **Browsing History** group, Click **Settings**. The Settings window opens.
- 3 Make sure that the “Check for newer versions of stored pages” option is set to Every time I visit the web page.
- 4 Click **OK** to close the Settings window.
- 5 Click **OK** to close the Internet Options window.

To disable caching with Microsoft Internet Explorer (v5 only)

- 1 Choose **Internet Options** from the **Tools** menu. The Internet Options window opens.
- 2 Click **Settings** in the **Temporary Internet files** group. The Settings window opens.
- 3 Make sure that the Check for newer versions of stored pages option is set to Every visit to the page.
- 4 Click **OK** to close the Settings window.
- 5 Click **OK** to close the Internet Options window.

To disable caching with Microsoft Internet Explorer 4.01 to 5

- 1 Choose **Internet Options** from the **View** menu. The Internet Options window opens.
- 2 In the **General** tab’s **Temporary Internet Files** group, click the **Settings** button. The Settings window opens.
- 3 Make sure that the Check for newer versions of stored pages option is set to Every visit to the page.
- 4 Click **OK** to close the Settings window
- 5 Click **OK** to close the Internet Options window.

To disable caching with Microsoft Internet Explorer on Mac OS

- 1 Choose **Preferences** from the **Edit** menu. The Internet Explorer Preferences window opens with a list of preference categories on the left side of the window.
- 2 Locate and click **Advanced** (listed under **Web Browser**). The advanced options for the browser are displayed in the right side of the window.
- 3 In the **Cache** group, choose **Always** for the **Update pages** option.
- 4 Click **OK** to save your options and close the window.

To disable caching with Netscape Navigator

- 1 Choose **Preferences** from the **Edit** menu. The Preferences window opens.
- 2 In the **Category** group (left frame), click the **plus sign (+)** next to the **Advanced** category.
- 3 Under **Advanced**, select the **Cache** option. The right side of the Preferences window changes to the Cache options.
- 4 At the bottom of the Cache group of options, be sure that the **Document in cache is compared to document on network** option is set to **Every time**.
- 5 Click **OK** to close the Preferences window.

The AN-3200 IP address must be in the trusted zone. Or, in IE, you will see a yellow bar with a script warning when you try to download a .csv file, follow these steps to configure your browser.

To add your AN-3200 to the trusted zone:

1. From within Internet Explorer, click “Tools”, in the drop-down menu, click “Internet Options”.
2. In the “Internet Options” dialog box, select the “Security” tab.
3. From Zones, select “Trusted sites” (large check mark).
4. Below Zones and next to “Trusted sites”, click the “Sites” button.
5. You will be prompted with the following:

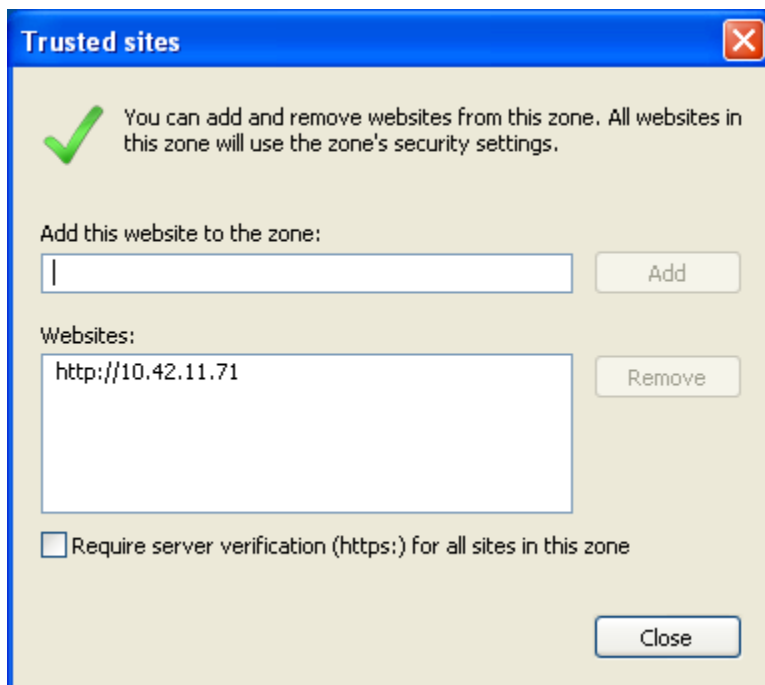

Enter your unit’s IP address in the top field and click the “Add” button which will add the IP address to the trusted zone.

6. Click Close, then OK.

APPENDIX H NOTES ON SAVING THE EVENT FILE AS .CSV

Opening the .csv file with Excel corrupts the time column.

When saving the event file as a .csv and then opening this file with Excel, the data in the time column gets corrupted. The reason is that Excel automatically formats this column as a type “general” and therefore tries to interpret the time as a number.

The work around is to save the file as a .txt, and then when opening this file with Excel tell Excel to format the time column as text.

Download .csv button prompts a yellow script bar blocking the yes/no question box.

The AN-3200 IP address must be in the trusted zone. Or, in IE, you will see a yellow bar with a script warning when you try to download a .csv file, follow these steps to configure your browser.

To add your AN-3200 to the trusted zone:

1. From within Internet Explorer, click “Tools”, in the drop-down menu, click “Internet Options”.
2. In the “Internet Options” dialog box, select the “Security” tab.
3. From Zones, select “Trusted sites” (large check mark).
4. Below Zones and next to “Trusted sites”, click the “Sites” button.
5. You will be prompted with the following dialog box:

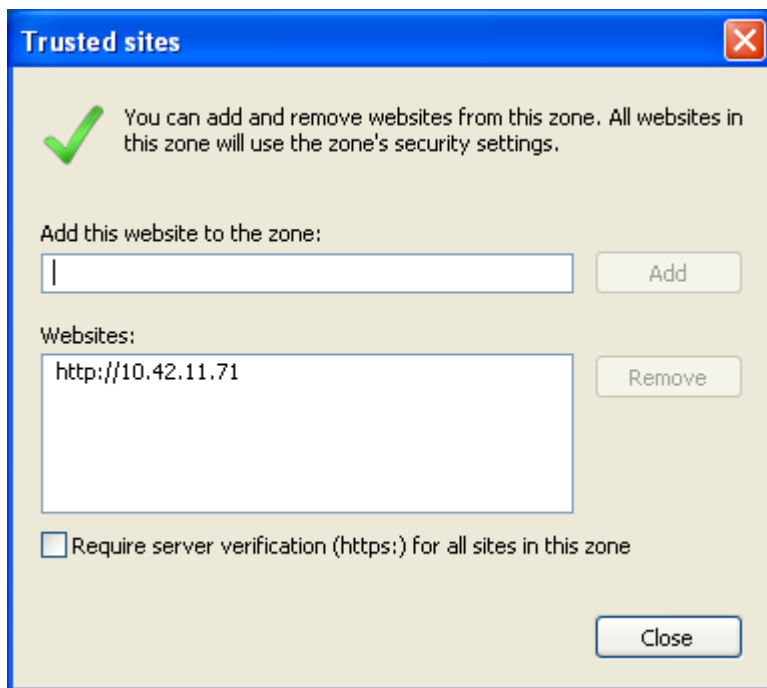

Enter your unit’s IP address in the top field and click the “Add” button which will add the IP address to the trusted zone under “Websites”.

6. Click Close, then OK.

Formatting the Excel .csv file for milliseconds

Excel does not have a standard number format for milliseconds. It can be added using the custom formatting.

1. Select the top timestamp in your spreadsheet.
2. Right click the cell and select Format Cells
3. Under Number, select Custom
4. The format should present hh:mm:ss.0
5. Add two extra 0's so it looks like this: hh:mm:ss.000
6. Copy this format to all cells in this column

APPENDIX I ALTERNATE METHOD FOR ETHERNET CONFIG

If either Modbus or DNP options are enabled, then use the Annunciator Configurator application to setup the Ethernet port. Otherwise, use this procedure. The Ethernet configuration can be set through the serial port on the back of the unit while connected to a terminal emulation program on a PC. In order to do this, you will need to gain access to the Communications card in the unit. Remove the window assembly from the CSM cell to gain access to the Communications card. Please refer to the System Configuration and Setup section of this manual to locate the CSM cell and the Communications card. To configure the Ethernet port:

- 1) Power up the unit and wait 60 seconds after unit is operational.
- 2) Locate the 2 pushbutton microswitches on the front edge of the Communications card. The pushbuttons are facing out of the unit.
- 3) Press the lower microswitch. This will set a flag in the database that will take affect upon the next reboot.
- 4) Power off the unit.
- 5) Connect a serial cable from the serial port on the back of the unit to a serial port on the PC.
- 6) Open up a terminal emulation program as shown in the following figure, and configure it as follows: 9600 baud, 1 stop bit, no parity, turn off local echo.
- 7) Power on the unit.
- 8) After the Communications card boots up, a numbered menu will be presented in the in the terminal program. Follow the menu choices to configure the Ethernet Port Settings on the unit. Save & apply the new settings.

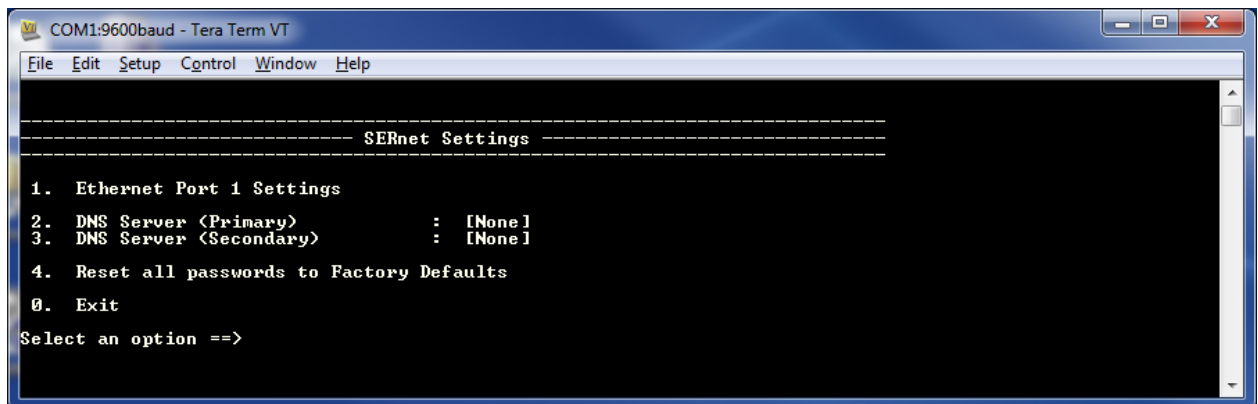

APPENDIX J

TELEPHONE / FAX NUMBER LIST

This errata sheet provides an easy-to-use reference for all major departments. Use these numbers for ordering equipment, application assistance, technical support, and scheduling field service

Please Note: Your instruction manual may contain other phone and fax numbers; this list will take precedence.

MAIN OFFICE

AMETEK Power Instruments – Rochester

255 North Union St., Rochester, NY 14605

DEPARTMENT/PRODUCT LINE	TELEPHONE	FAX
MAIN PHONE	585-263-7700	585-262-4777
FIELD SERVICE	800-374-4835	585-238-4945
REPAIRS/RETURNS	888-222-6282	585-238-4945
SALES SUPPORT	800-950-5503	585-454-7805

FAR EAST OFFICE

AMETEK Power Instruments
271 Bukit Timah Road, #03-09
Balmoral Plaza, Singapore 259708
Tel: 65-732-8675
Fax: 65-732-8676

UK OFFICE

AMETEK Power Instruments
Unit 20, Ridgeway
Donibristle Industrial Estate
Dunfermline, UK
Tel: 1383-825630
Fax: 1383-825715

PROCEDURES FOR FACTORY REPAIR AND RETURN

- B. Obtain a Returned material Authorization (RMA) number by calling AMETEK Repair Sales and giving the following information:

Model and Serial Number of the equipment
Failure Symptom – Be Specific
Approximate date of installation
The site name and address of the failed equipment
Complete shipping information for the return of the equipment if other than the operating site

Name and telephone number of person to contact if questions arise.

Enclose the information with the equipment and pack in a commercially accepted shipping container with sufficient packing material to insure that no shipping damage will occur. Mark the outside of the container with the RMA number. Ship to the appropriate location

Attention: Repair Department
AMETEK Power Instruments
255 North Union Street
Rochester, New York 14605 USA
Tel: (888) 222-6282
Fax: (585) 238-4945

Your emergency equipment will be tested, repaired and inspected at the factory. Factory turnaround is ten working days or less (excluding shipping time).

For emergency service or repair status information, please contact the AMETEK Repair Sales Engineer at (800) 374-4835.

WARRANTY

AMETEK warrants equipment of its own manufacture to be free from defects in material and workmanship, under normal conditions of use and service. AMETEK will replace any component found to be defective, upon its return, transportation charges prepaid, within one year of its original purchase. AMETEK will extend the same warranty protection on accessories that is extended to AMETEK by the original manufacturer. AMETEK assumes no responsibility, expressed or implied, beyond its obligation to replace any component involved. Such warranty is in lieu of all other warranties expressed or implied.