



SERIES 90A

Installation and Configuration Manual

Publication 1085-355
Rev E
May. 2010

AMETEK POWER Instruments
255 N. Union Street
Rochester, New York 14605

Tel: (800) 881-4156
Fax: (585) 238-4945
Web: www.ametekpower.com

Please Read This First!

IMPORTANT NOTES

**THOROUGHLY READ AND UNDERSTAND THE SAFETY SECTION BEFORE
ATTEMPTING TO INSTALL AND ENERGIZE A SYSTEM**

**UNAUTHORIZED MODIFICATIONS OR REPAIRS WILL INVALIDATE THE
AMETEK WARRANTY PLEASE CONTACT THE AMETEK CUSTOMER
SERVICES DEPARTMENT BEFORE TAKING SUCH ACTIONS**

**STANDARD DEFAULT SETTINGS ARE INDICATED IN THIS MANUAL, TO
WHICH SERIES 90A ANNUNCIATORS WILL BE SET SHOULD NO SPECIFIC
CONFIGURATION OR SET UP DETAILS BE SUPPLIED WITH PURCHASE
ORDERS**

Table of Contents

PRODUCT OVERVIEW	1
SAFETY	1
Construction	1
System Front View	1
System Rear View	1
Module Cell	2
Cell Assembly	2
Module Cell Configurations	3
Annunciator Windows	3
Annunciator Model Code Definition	4
SYSTEM CONFIGURATION AND SET-UP	6
Hardware Configuration	7
Field Contact Type	7
Field Contact Voltage (FCV)	8
CSM Address	10
I/O Module Configuration	11
I/O Module Configuration	12
Display Module	13
Common Service Modules	14
Communication Modules	15
Serial	15
Ethernet	16
Ground Fault Detector Module	17
Power Supply Modules	17
Field Contact Voltage Supply Modules	18
IRIG-B Module	18
INSTALLATION	19
Mounting	19
Panel Mounting (option PM, PC)	19
19" Rack Mounting (option RK)	21
NEMA Enclosure (option N4, N4PB)	22
Surface (Wall) Mounting (option S)	23
Weather Tight NEMA Front Cover (option NCB, NCT)	25
External Power Supply Mounting	29
120/230VAC Power Supply	29
125VDC Power Supply	29
Wiring	30
Input Wiring	30
Common Field Contact Voltage	30
Isolated Field Contact Voltage	31
Input / Relay Wiring for Full Size Windows (using one I/O Card)	32
Input/Relay Wiring For Half Size Windows (using one I/O Card)	33
Input/Relay Wiring For Half Size Windows (using one I/O Card)	34
Input Wiring with Half Size Windows (using two I/O Cards)	35
Repeat Relay Wiring for Half Size Windows (using two I/O Cards)	36
Input/Relay Wiring for Quad Size Windows (using two I/O Cards)	38
Common Service Cell Wiring (with Integral Pushbuttons)	39
Common Service Wiring (with I/O Modules)	40
Connecting Power	41
120/230 VAC & 125VDC Input Power	41
Field Contact Voltage	41
Power Requirements	42
External AC supply:	42

Integral AC supply:	42
Integral Power Supply	43
125VDC or 120/230 VAC Integral Power Supply	44
125VDC or 120/230VAC Integral Field Contact Voltage (FCV) Supply	45
120/230 VAC and 125 VDC Integral Power Supply Wiring.....	46
24VDC Integral Power / FCV Supply.....	47
48VDC Integral Power Supply.....	48
24 and 48 VDC Integral Power Supply Wiring.....	49
External Power Supply	50
125 VDC External Power Supply Wiring	51
120/230 VAC External Power Supply Wiring.....	52
SOFTWARE CONFIGURATION	53
Application.....	53
Software Installation	53
Software Configuration Instructions	54
Reviewing or editing the Factory Configuration.....	54
Creating a new Configuration	55
Software Configuration Menus.....	56
Main menu overview.....	56
File Menu	56
Options Menu.....	56
View Menu	56
Connections Menu	56
Help Menu.....	56
File	57
Options.....	59
View Configuration (Text).....	60
Configuration Wizard.....	65
System	66
Input Configuration	69
Alarm Numbering	69
Switch Inputs.....	78
External Switch Function Settings	78
Test Configuration.....	79
Other System Configurations	79
Modbus.....	80
Settings for Ethernet (Option ETH)	80
Common Modbus Settings	81
DNP3.0	83
Settings for Ethernet (Option ETH)	83
Common DNP Configuration Settings.....	84
SYSTEM SPECIFICATIONS	87
Inputs.....	87
Display	87
Repeat Relay Outputs	88
Alarm Sequence	89
Controls	90
System Relays.....	90
Audible Devices.....	90
Communications.....	91
Time Stamped Alarms	91
Power Requirements	91
Mechanical	92
Connections / terminations	92
Environment	93
Electrical	93
Certifications.....	94

Servicing	95
Module Removal.....	95
ESD	96
APPENDIX A	97
Operational Sequences	97
LEGEND	102
APPENDIX B	103
Modbus Data Formats	103
Alarm State Mode	103
Point Mode.....	104
AN3135 Mode.....	105
Event Data	106
Modbus Addresses	107
Default Values	107
APPENDIX C	108
DNP Data Formats	108
Device Profile Document	108
Implementation Table	109
Pushbutton Controls	110
SERIES 90A Data Map	111
Binary Inputs.....	111
Binary Input Change with Time (SER Option)	111
APPENDIX D	112
Window Assembly Details	112
Window Legends	112
Window Colors.....	112
Window Assembly	113
APPENDIX E	115
Telephone / Fax Number List	115
PROCEDURES FOR FACTORY REPAIR AND RETURN.....	117
Warranty	117

SCOPE

This manual describes the installation and configuration of the SERIES 90A annunciator system. This includes operation of its associated configuration software.

Glossary of Terms

Cell:	Refers to a single module housing that can accommodate several boards. An Annunciator that is 3 rows high by 4 columns wide consists of 12 Cells.
Module:	Refers to an individual electronic board. There are a variety of boards used in the Annunciator System for inputs, outputs, communications, etc.
N.O.	Normally Open. Contact state is open when normal, closes upon alarm.
N.C.	Normally Closed. Contact state is closed when normal, opens upon alarm.
Energized:	Typically refers to the relay coil state when normal. The coil de-energizes (voltage removed) when in alarm or while activated.
De-Energized:	Typically refers to the relay coil state when normal. The coil energizes (voltage applied) when in alarm or while activated.
Form A	Type of relay contact, SPST (single pole, single throw). Open in the normal state, closes upon alarm or while activated.
Form B	Type of relay contact, SPST (single pole, single throw). Closed in the normal state, opens upon alarm or while activated.
Form C	Type of relay contact, SPDT (single pole, double throw). Open and closed contact with common pole. Both change state when in alarm or while activated.
FCV:	Field Contact Voltage. Field contact or wetting voltage for alarm inputs.
CSM:	Common Service Module. The CSM provides common alarm controls and output relays. Typically located in the bottom right cell.
I/O:	Input/Output. This refers to a board that accepts the customer Field Contact Inputs, provides outputs to the LED Display and can provide optional repeat relays.

PRODUCT OVERVIEW

SAFETY

The following safety symbols are used on the SERIES 90A:



Caution, risk of danger. Refer to the Instruction Manual.



Caution, risk of electric shock.



Protective Earth Conductor Terminal

The SERIES 90A is CE certified for operation under the following conditions:

Indoor Use (unless mounted in NEMA-4 enclosure option)

Altitude up to 2000 m

Operating Temperature Range: -20 TO 50 °C (-4 to 122°F)

Relative Humidity: 20-95% RH

Mains supply voltage fluctuations: +/- 10% of nominal

Transient Over voltages: 2500 V (Installation or Measurement Category II)

Pollution Degree 2

In product configurations with 125VDC or 120VAC Field Contact Voltage (options: D, DC, D/ISO, Y/ISO), the system must be equipped with the lockable front door (options NCB, NCT) or NEMA Enclosure (options N4, N4PB) Annunciator Model Code Definition on page 4.

For FM option (refer to option codes), the required door may be supplied by Ametek, a panel shop or the customer. The door must meet the FM standard for requiring a tool to open or remove the door to allow access to the front of the Annunciator.

Also, 120/230VAC & 125 VDC Input Power (options A, B, C) must use external power supplies, unless the front door or NEMA enclosure is used. All other product configurations can be installed in any enclosure as specified in the model number table, item 1.

Installation and start-up must be carried out by trained and qualified personnel.

If the unit is not installed and operated as specified the protection provided by the unit may be impaired.

Before start-up it is important to ensure that:

Before start-up, it is important to ensure that:

1. The unit can be switched off by a switch, or a circuit breaker, clearly marked as the disconnecting device for the unit. The minimum rating of the disconnecting device is:
 - 5 Amps for 120 Vac or 230 Vac power
 - 10 Amps for 24 or 48 VDC power
2. The disconnecting device is located in close proximity to the unit and must be marked as the disconnecting device for the unit.
3. The protective earth terminal is properly connected to protective earth.
4. The line has been connected correctly and protection is provided against electric shock.

Proper ventilation is provided by at least 6 inches (15.25 cm) above and below the unit

CONSTRUCTION

The SERIES 90A is a modular design constructed from a matrix of cells up to 13 high by 13 wide. The cells can be configured for 1, 2, 3 or 4 points per cell. Each cell provides front access to the electronics and all wiring connections are made to the rear of the unit. Each cell can accept several modules in various combinations, consisting of I/O Cards, Common Service Modules, Power Supplies and Option Modules. The Common Service Module (CSM) is typically located at the lower right cell of the unit and the other cells are used for I/O.

System Front View



System Rear View

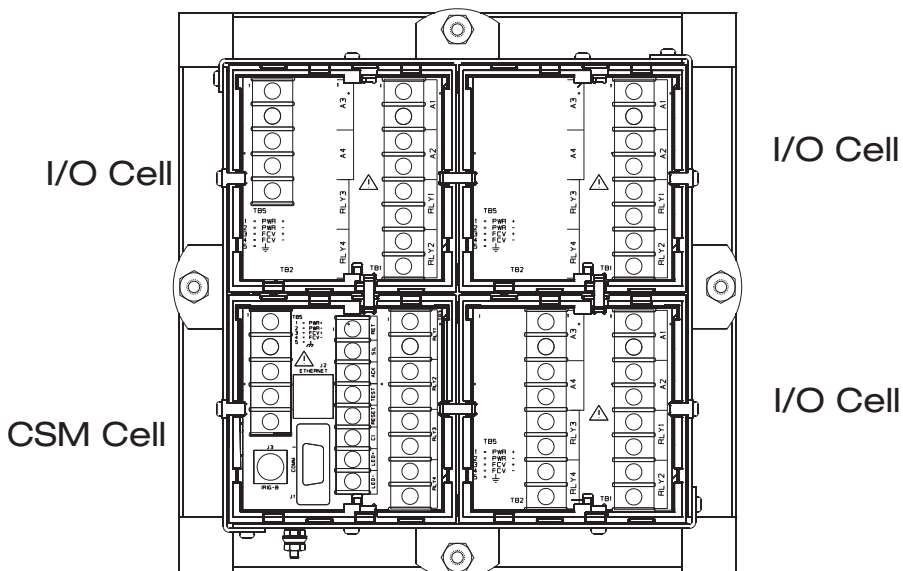

Module Cell

The Annunciator is a modular construction made from individual cells, allowing any size high or wide up to 13. All cards are removable from the front of the unit, after removing the window or pushbutton assembly.

Cell Assembly

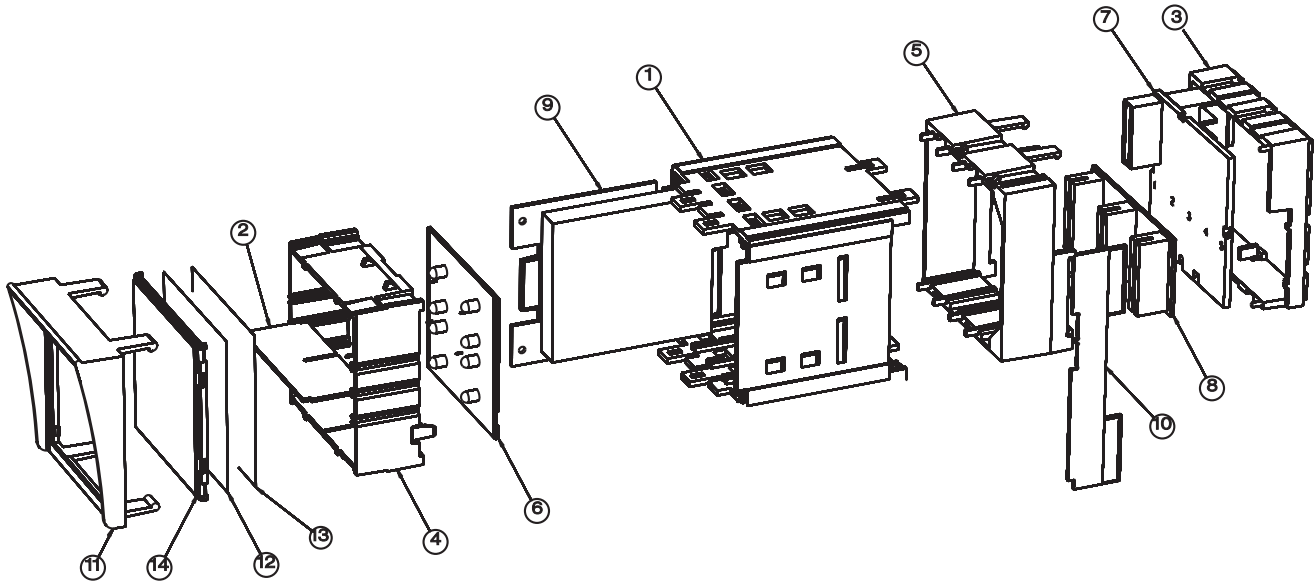

Item #	Part Description	Item #	Part Description	Item #	Part Description
1	Module Cell	6	Display Board	11	Window Housing
2	Window Divider	7	Back-plane Assembly	12	Window Legend
3	Back-plane Housing	8	Interconnect Board	13	Color Diffuser
4	Display Housing	9	Module (see list)	14	Window
5	Rear Cell Housing	10	Row Interconnect Board		

Available Modules:

- **I/O** Input / Output Module, with optional Repeat Relays
- **LED** LED Display Module
- **CSM** Common Service Module & Sequential Events Recording CSM
- **COMM** Communication Module: Serial & Ethernet)
- **PS** Power Supply: Integral AC/DC Universal, Integral DC/DC
- **FCV Supply** Field Contact Voltage Supply: Integral AC/DC Universal
- **IRIG-B** Time Synchronization Input Module used for Sequential Events Recording
- **Ground Fault** Ground Fault Detector Module

Module Cell Configurations

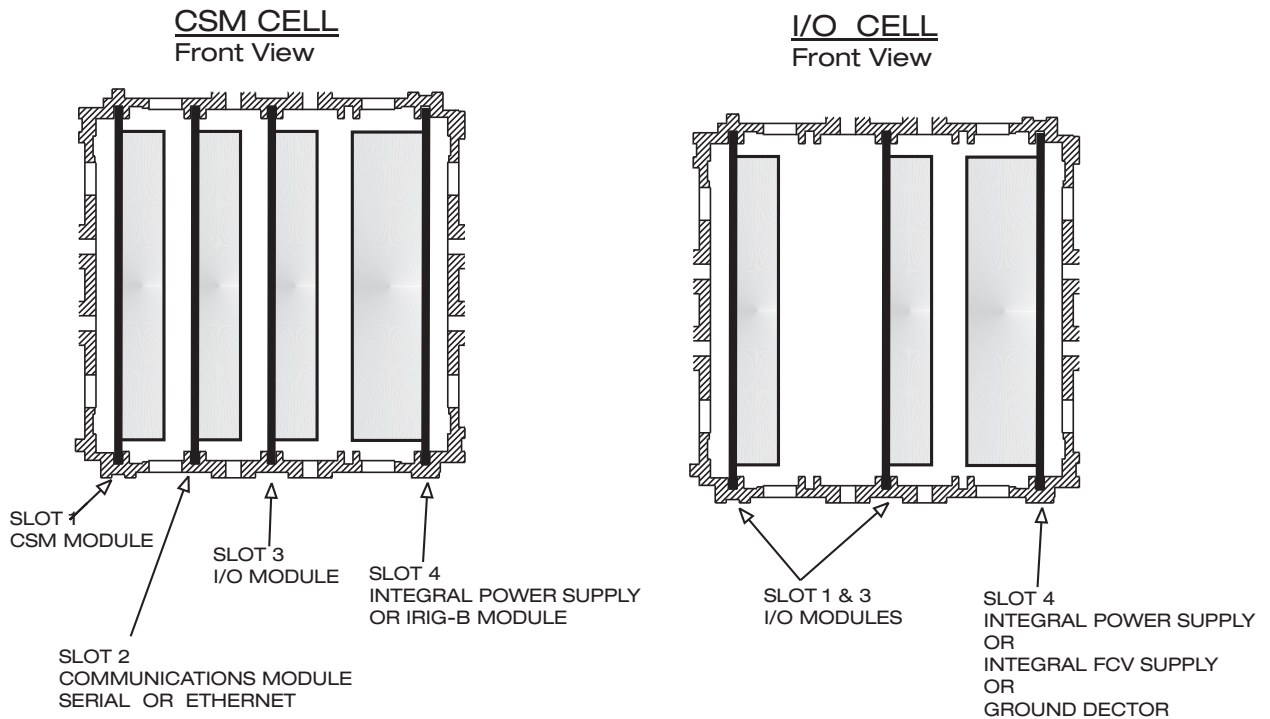

Note: Slot 5 of the I/O cell is also used for a row to row interconnect board (item #10 on cell assembly figure), which is installed for every row of the Annunciator. When installed; no other card or power supply can be inserted in that slot. All other unused slot 5 positions in that row can be used for power supplies or a ground detector. (This will be factory configured)

Annunciator Windows

The Annunciator windows come in four sizes as shown below. Legends can be laser printed on transparency film and inserted into the window frame. Colored filters are inserted behind the legends. Reference the appendix for additional details.

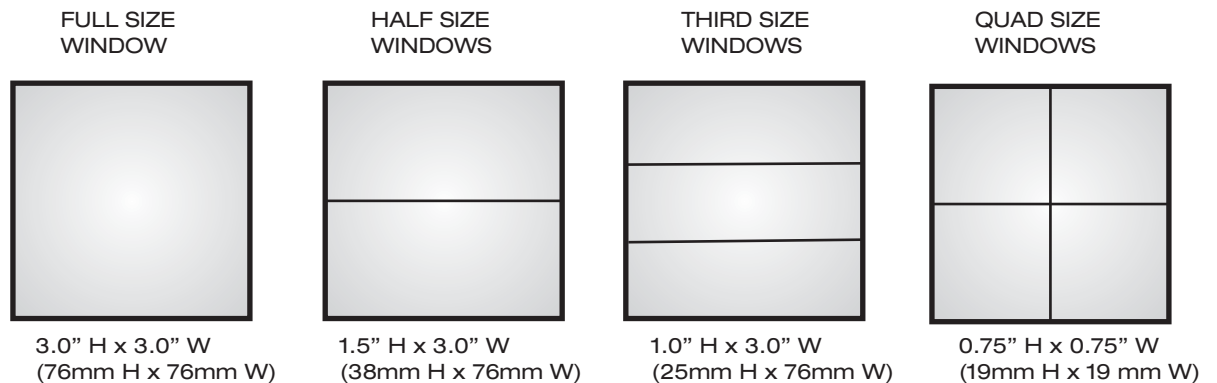

ANNUNCIATOR MODEL CODE DEFINITION

SERIES 90A Model Number

SERIES 90A-

Item 1 Mounting Options	Item 2 # of Cells High	Item 3 # of Cells Wide	Item 4 Common Service	Item 5 Window Size	Item 6 Active Points	Item 7 Window Color
-	-	-	-	-	-	-
Item 8 Operational Sequence	Item 9 Repeat Relay	Item 10 Power Input	Item 11 Field Contact Voltage	Item 12 Window Legends	Item 13 Comm. Options	Item 14 Options

Example: SERIES 90A -PM-3H-6W-INTB-2-34-W-AF-RR-B-X-TP-MB-TS-IB-RLY

Item 1 Mounting Options

PM	Semi-Flush Panel Mounting
PC	Semi-Flush Panel Mounting w/rear cover
RK	19" Rack Mounting (5 wide systems only)
S	Surface (Wall) Mounting (1H to 5H x 2W to 5W)
NCB	Weather-tight NEMA Front Cover w/ ¼-20 Bolts
NCT	Weather-tight NEMA Front Cover w/T Handle
N4	NEMA-4 Enclosure (1H to 6H x 3W to 8W)
N4PB	NEMA-4 Enclosure w/PB (1H to 6H x 3W to 8W)

Item 2,3 Annunciator Size

# of Cells High (1-13)	# of Cells Wide (2-13)
---------------------------	---------------------------

Item 4 Common Service Cell (lower right cell)

INTB	Integral Pushbuttons (ACK, SIL, TEST, RESET)
NPB	Pushbuttons replaced w/ a Half or Full Size Window
Note:	For either selection above, external pushbuttons can be connected to the Annunciator terminal blocks.

Item 5 Window Size

4	Quad Size, 4 inputs per cell, ea 1.5"H x 1.5"W
3	Third Size, 3 inputs per cell, ea 1.0"H x 3.0"W
2E	Half Size, 2 inputs per cell, ea 1.5"H x 3.0"W
2S	Half Size, 2 inputs per cell, ea 1.5"H x 3.0"W
2	Half Size, 2 inputs per cell, ea 1.5"H x 3.0"W
1E	Full Size, 1 input per cell, ea 3.0"Hx3.0"W
IMW	Intermixed window size

Note:
Option **1E** indicates that the cell is expandable up to 2 inputs.
Option **2E** indicates that the cell is expandable up to 4 inputs.
Option **2S** indicates one input module per single input provided.
Do not include the CSM Cell in your quantity.

Item 6 Active Points

Total # of active points

Item 7 Window Color

W	White Window Filter
R	Red Window Filter
A	Amber Window Filter
G	Green Window Filter
Y	Yellow Window Filter
B	Blue Window Filter
IMC	Intermix color, matrix must be included

Item 8 Operational Sequence

LN, AO, AONL, AF, AFNL, FR, AM, FRM, AS, ASFR, ASFRM, TFS, TFSFRM, TFSM, ARR, FRR, VS, VSRR, MC	Intermixed Sequences (up to 4 available)
---	--

Item 9 Repeat Relay Option

RR	Auxiliary Repeat Relay Provided for every Input. (Can be field configured to follow: alarm input status, alarm sequence operation or Lamp Flash. Relays can be set for normally energized or de-energized operation and are jumper selectable for a Form A or Form B contact arrangement).
FRC	Auxiliary Repeat Relay Provided for every Input with Form C (SPDT) Contacts. (Can only be used with Window Size 1E or 2S).
2RR	Two Repeat Relays for every input. (Selectable for a Form A or Form B contact arrangement. Can only be used with Window Size 1E or 2S.)
NR	No Repeat Relays required (Note: Can only choose one selection from above).

Item 10 Power Input

F	24 VDC
E	48 VDC
C	125 VDC
B	120 VAC, 60 HZ
A	230 VAC, 50 HZ

Item 11 Field Contact Voltage (FCV)

Field Contact Voltage internally supplied by AMETEK, with common system-wide FCV return.	
*For System Input Power Voltages of 120/230VAC or 125VDC.	
D	125 VDC FCV
X	24 VDC FCV
Field Contact Voltage externally supplied by Customer, internally bussed to all input modules.	
DC	125 VDC FCV supplied by Customer
TC	48 VDC FCV supplied by Customer
XC	24 VDC FCV supplied by Customer
JC	12 VDC FCV supplied by Customer
Field Contact Voltage externally supplied by Customer. Every input is isolated and requires a separate FCV connection.	
D/ISO	125 VDC FCV supplied by Customer
T/ISO	48 VDC FCV supplied by Customer
X/ISO	24 VDC FCV supplied by Customer
J/ISO	12 VDC FCV supplied by Customer
Y/ISO	120 VAC FCV supplied by Customer
NR	No Field Contact Voltage (Serial Input Only)

Item 12 Window Legends

TP	Legends printed on Transparency Film (field changeable)
E	Legends Engraved on Windows
<i>Note: Window engraving or printed legends can be provided at the factory at no charge if provided 1 week before shipment.</i>	

Item 13 Serial Communications

SIM	Modbus Serial Input Only (no Field Contact Inputs)
MB	Modbus Communications, Transmit or Receive
DNP	DNP 3.0 Communications, Transmit Alarms
SD	Serial ASCII Data Output of Time Stamped Alarms (Used with the Time Stamping option SER only.)
NR	None of the above Serial communication options installed
<i>Note: Can only select one of the above options. All options above are field selectable for RS-232 or RS-485 communications.</i>	

Item 14 Options

ETH	Ethernet Port (RJ-45 , T1 connection) (Used with Modbus or DNP Communication options. Must select option MB or DNP. Replaces RS-232/485 Serial Port.)
FR	1 msec Input Response (50 msec Standard) (This will capture alarms that last 1 msec or longer. If Time Stamping is required, select option SER instead)
SER	Time Stamping of alarms (4 ms resolution) (Each alarm is accompanied with a time stamp, containing point #, alarm state, time & date. The Time Stamp output can be selected as Serial ASCII Data to a printer or terminal [must select option SD], Modbus [must select option MB] or DNP [must select option DNP].)
SERFR	Time Stamping of alarms (1 ms resolution) (Each alarm is accompanied with a time stamp, containing point #, alarm state, time & date. The Time Stamp output can be selected as Serial ASCII Data to a printer or terminal [must select option SD], Modbus [must select option MB] or DNP [must select option DNP]. Option limited to 25 Cells)
IB	IRIG-B Time Sync Input (used with SER Option) (Standard BNC Input)

Item 14 Options (continued)

SP	Serial Printer used for Time Stamped Alarms (Used with SER option [time stamped alarms] and SD option [serial data output]. Modbus, DNP and Ethernet are not available when selecting this.)
GF	Ground Fault Detector (internally mounted) For 24, 48, 125VDC Field Contact Voltage (options X, D, XC, DC, TC)
RLY	Additional Two CSM Common Relays (Base system includes 2 CSM Common Relays configurable for Critical or Non-Critical Horn, Ringback Horn. The additional 2 CSM Common Relays can be configured for additional horns or Critical/Non-Critical Reflash or Fault, Power Fail, System Watchdog, or Ground Fault Detect)
SW	External Inhibit Switch Input (Software configurable for inhibit of LED Lamps, Horn, Repeat Relay Outputs or CSM Common Relay Outputs)
HN	Internal Horn
AS	Automatic Horn Silence (Can be used to silence any horn with software configurable delay up to 60 seconds, in 0.25 second increments. Independent setting for internal or external horns)
FS	Flash Synchronization. Synchronizes the flash rate to remote displays. Needs to be specified for each Annunciator that will be synchronized together. (Requires wiring between Annunciator Systems.)
CE	CE Certification CE Certification available for all configurations except for FCV options D, DC, D/ISO, Y/ISO. In these cases, a NEMA Enclosure (option N4, N4PB) or Front Cover (option NCB, NCT) is required. 120/230VAC & 125VDC Input Power provided via External Supplies unless the NEMA Enclosure or Front Cover is used.
STM	Moisture/ Fungus Proof Coating
FM	FM Class 1, Div.2 Groups A,B,C,D Certification FM Certification available for all configurations. A NEMA Enclosure (option N4, N4PB) or Front Cover (option NCB, NCT) is required. Power option A (230Vac), B(120Vac), C(125Vdc), (see ITEM 10), is provided via External Supplies only.

SYSTEM CONFIGURATION AND SET-UP

The SERIES 90A Annunciator is already factory configured per the model number. Most of the configuration of the system is made using software, however some settings such as relay contact arrangement (Form A or Form B) needs to be configured by the user. The default configurations are specified below:

Item		Default Setting	Configuration Method
Inputs	N.O. (normally open), N.C. (normally closed) Field Contact Inputs	N.O.	Software or Hardware *
	Field Contact Voltage (12, 24, 48, 125VDC, 120VAC) OR (24-125VDC)	Factory Configured Per Model Number	Hardware
	Common FCV (field contact voltage) or Isolated FCV		Hardware
	Input Module Address Setting		Hardware
	Operational Sequence (LN, AO, etc)		Software
	Sequence Grouping	1 group	Software
	Input Response	50 msec	Software
	Critical/Non-Critical Assignment	Non-Critical	Software
Optional Repeat Relays	Form A (normally open), Form B Contacts (normally closed)	Form A	Hardware
	Form C Contacts (SPDT)	Factory Configured Per Model Number	Hardware
	Energized or De-Energized Relays	De-Energized	Software
	Repeat Relay Operation	Follows Input	Software
CSM Functions	Auxiliary Contact Output Type (Form A, Form B)	Form A	Hardware
	Auxiliary Contact Output Mode (Energized or De-Energized)	De-Energized	Software
	Auxiliary Contact Output Operation (Horn, Reflash, Fault, Watchdog, Power Monitor, Ground Fault)	Critical Horn & Non-Critical Horn	Software
	Other system-wide functions	None Selected	Software
Serial Communication Module	RS-232 , RS-485	RS-232	Hardware
	RS-485 Termination Jumper	Out	Hardware
	Flash Synchronization (master/slave)	Master	Hardware

*** NO/NC Field Inputs can be configured via the software or hardware, but not both. Choose one method only.**

HARDWARE CONFIGURATION

Each Input/Output (I/O) module can accept up to two field contact inputs, with field contact voltage (FCV) provided either internally by the Annunciator or externally by the customer. Each input includes optical coupler isolation and can be selected for Normally Open (N/O) or Normally Closed (N/C) Field Contact Inputs through the software configuration or module jumpers. The I/O module provides outputs to the Display Module. Optional relays can be added to the I/O module for repeating the alarm status. Up to two I/O cards can be inserted into Card Slots 1 & 3 of a single cell for a maximum of 4 points per cell. The Cell with the Common Service Module can also support one I/O Module (in slot 3), in place of the Integral Pushbuttons.

There are two versions of input modules. One version has headers and jumpers used to configure the FCV and the CSM address, while the other versions are designed with an input circuit capable of accepting an input range of 24vDC to 125vDC and use a rocker switch for the CSM Address.

Both versions of the I/O module are configured via jumpers for: (NO/NC) and Form A, B, C Relay Contacts.

Refer to the following table and to the part number affixed to the module to determine the type of module. Note that all modules in a systems shipped from the factory will contain the same type of configuration.

Table 1 Module Types

Description	Header/jumper for FCV and CSM address	No FCV Jumpers required Switch for CSM address
	Part Number	Part Number
3/4 PT I/O W/RELAY	1085-250	1087-060
1/2 PT I/O W/RELAY	1085-286	1087-241
1/2 PT I/O NO RELAY	1085-287	1087-242
3/4 PT I/O NO RELAY	1085-288	1087-243
1/2PT SER INPUT ONLY	1085-304	1087-244
1/2PT SER INPUT ONLY	1085-305	1087-245

Field Contact Type

The I/O module supports both N/O & N/C inputs through the *software configuration*, as detailed in the next section. N/O refers to Normally Open Field Contacts (open in Normal State, Closed in Alarm State) and N/C refers to Normally Closed Field Contacts (closed in Normal State, open in Alarm State) As an alternative, the N/O and N/C settings may be selected via jumper P5 & P6 on the I/O Module.

NOTE: The NO/NC setting must only be configured via one method (hardware or software). It is recommended to use the software method to avoid any confusion.

Field Contact Voltage (FCV)

Refer to Table-1 Module Types above to determine the type of FCV configuration installed.

I/O modules with the part number starting with 1085- supports Field Contact Voltages of 12, 24, 48, 125 through Jumper P1. The Field Contact Voltage may be selected as Common throughout the whole system or Isolated from input to input. This is selected via jumpers J1 & J2.

I/O modules with the part number starting with 1087- supports Field Contact Voltages with a range of 24 through 125VDC with no need for configuration jumpers. The Field Contact Voltage may be selected as Common throughout the whole system or Isolated from input to input. This is selected via jumpers J1 & J2.

NOTE: The Annunciator is already factory configured per the selections in the model number.

Repeat Relay Configuration Table

Relay Operation Mode	Relay Contact Status (shown in Normal State)	Relay Coil Status (shown in Normal State)
Repeat Relay Output Follows Input Contact State	OPEN (Form B)	ENERGIZED
	OPEN (Form A)	DE-ENERGIZED
	CLOSED (Form A)	ENERGIZED
	CLOSED (Form B)	DE-ENERGIZED
Repeat Relay Output Latches on Alarm until Acknowledged or Reset	OPEN (Form B)	ENERGIZED
	OPEN (Form A)	DE-ENERGIZED
	CLOSED (Form A)	ENERGIZED
	CLOSED (Form B)	DE-ENERGIZED

NOTE: Option FRC uses a Form C output, which is a SPDT (Single Pole Double Throw) contact. Option 2RR indicates two Repeat Relays for a single alarm input. (used with 1E & 2S Window Sizes) Jumpers P2,3,4 are used to select Form A, B and C modes. The options for the Relay Operation Mode and Relay Coil Status (normally energized or de-energized relays) are selected using the software configuration tool. (Reference the instruction manual section for Software Configuration.

CSM Address

Each I/O Module requires an address in order for communications to the CSM module. The Address settings are required for configuring any per point parameters and for mapping of serial communications.

There are two versions of input modules using different methods of setting the address. Refer to Refer to Table-1 Module Types to determine which module is in your system.

Older version

(Part numbers starting with 1085-)

The CSM address uses jumpers (J9) to indicate a binary address, starting at 0 and incrementing by one for every module in the system, from left to right, top to bottom. In cases where there is only one module per cell (Window code 1E) the binary address will increment by two. Starting at 0 in the first cell, 2 in the second cell, 4 in the third cell etc. Zero is set when all jumpers are removed.

Newer version

(Part numbers starting with 1087-)

The CSM address uses a rocker switch (SW1) to indicate a binary address, starting at 0 and incrementing by one for every module in the system, from left to right, top to bottom. In cases where there is only one module per cell (Window code 1E) the binary address will increment by two. Starting at 0 in the first cell, 2 in the second cell, 4 in the third cell etc. Zero is set when all switches are set of off.

NOTE: Care should be taken when removing and replacing I/O modules to insure that they are replaced into the cell from which they are removed. Failure to do so will result in out-of –sequence address.

I/O Module Configuration

(1085-xxx modules containing FCV jumpers)

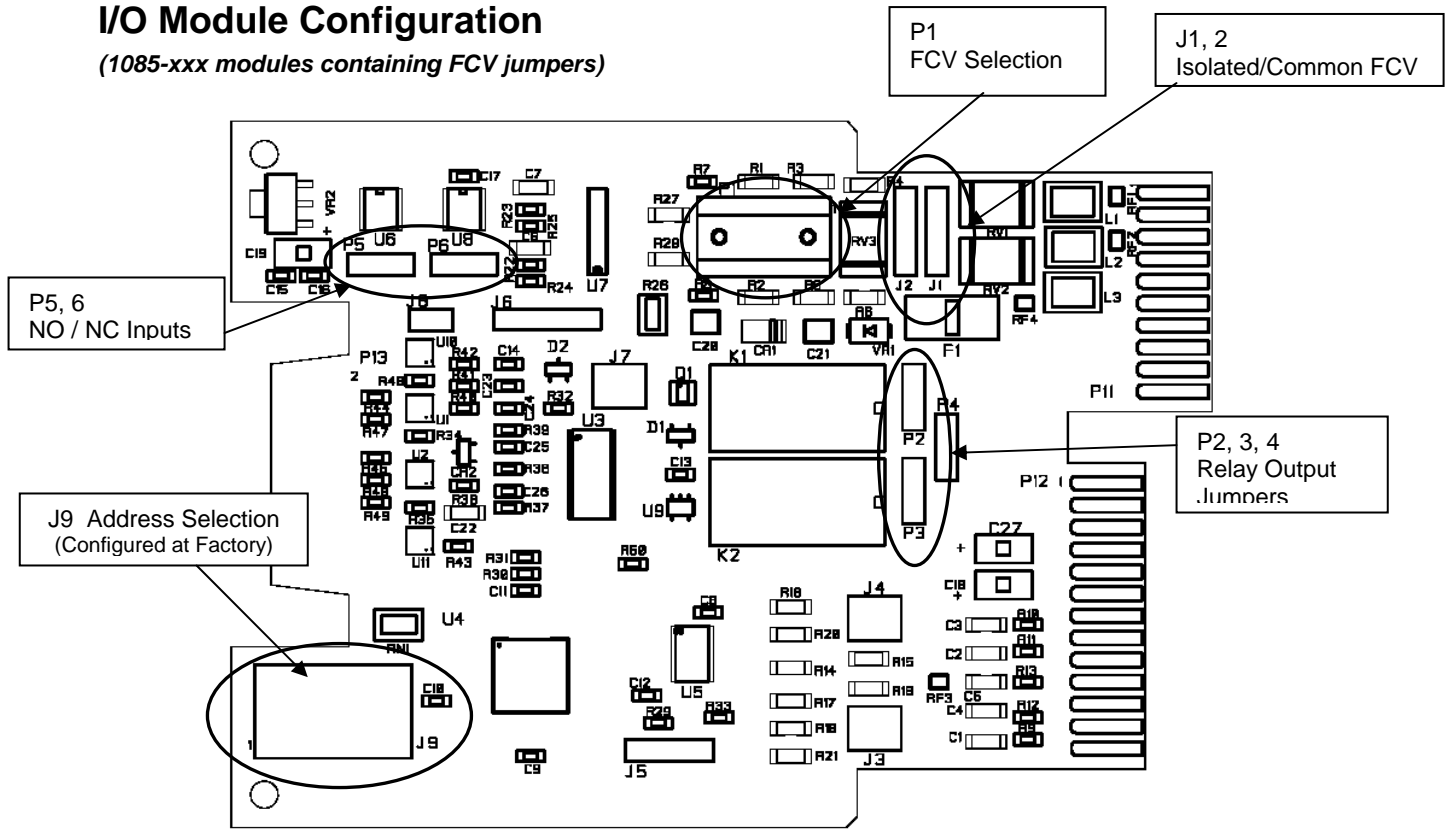

P1: INPUT VOLTAGE RANGE SELECTION

125 Vdc, 120Vac:



48 Vdc:



24 Vdc:



12 Vdc:



J1,J2: INPUT ISOLATION SELECTION

ISOLATED INPUTS



COMMON INPUTS WITH FCV



P5,P6: INPUT NORMALLY OPEN (NO)/NORMALLY CLOSED (NC)

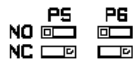

P2,P3,P4: RELAY OUTPUT SELECTION

	FORM A (N.O.)	FORM B (N.C.)	FORM C (SPDT)
RELAY #1:	P2 <input type="checkbox"/>	P2 <input type="checkbox"/>	P2 <input type="checkbox"/> P4 <input type="checkbox"/>
RELAY #2:	P3 <input type="checkbox"/> P4 <input type="checkbox"/>	P3 <input type="checkbox"/> P4 <input type="checkbox"/>	N/A

I/O Module Configuration

(1087-xxx modules with auto range FCV)

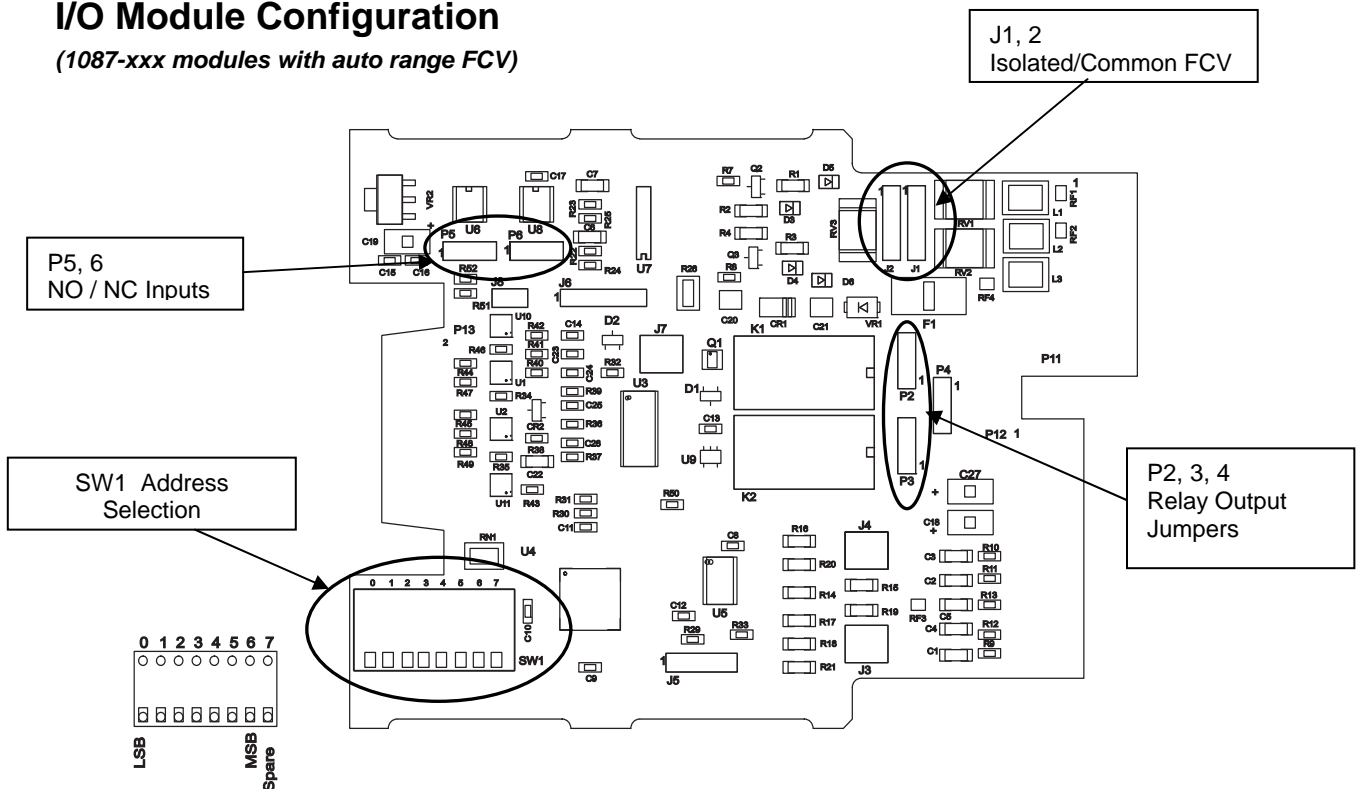

SW1 ADDRESS SELECTION

J1,J2: INPUT ISOLATION SELECTION

ISOLATED INPUTS



COMMON INPUTS WITH FCV



P5,P6: INPUT NORMALLY OPEN (NO)/NORMALLY CLOSED (NC)



P2,P3,P4: RELAY OUTPUT SELECTION

	FORM A (N.O.)	FORM B (N.C.)	FORM C (SPDT)
RELAY #1:	P2	P2	P2 P4
RELAY #2:	P3 P4	P3 P4	N/A

Display Module

The Display Module provides the LED indication for up to 4 window sizes (Full Size, Half, Third and Quad). Each display module plugs into one or two I/O cards, depending on the window size and input quantities. There are several variations of display modules as noted by the window size in the model number:

Version	Window Size, Configuration
1	1E, 2
2	2S, 2E, 4
3	3
4	1E, 2 (in CSM Cell)

There is no setup required for these modules. (Factory configured)

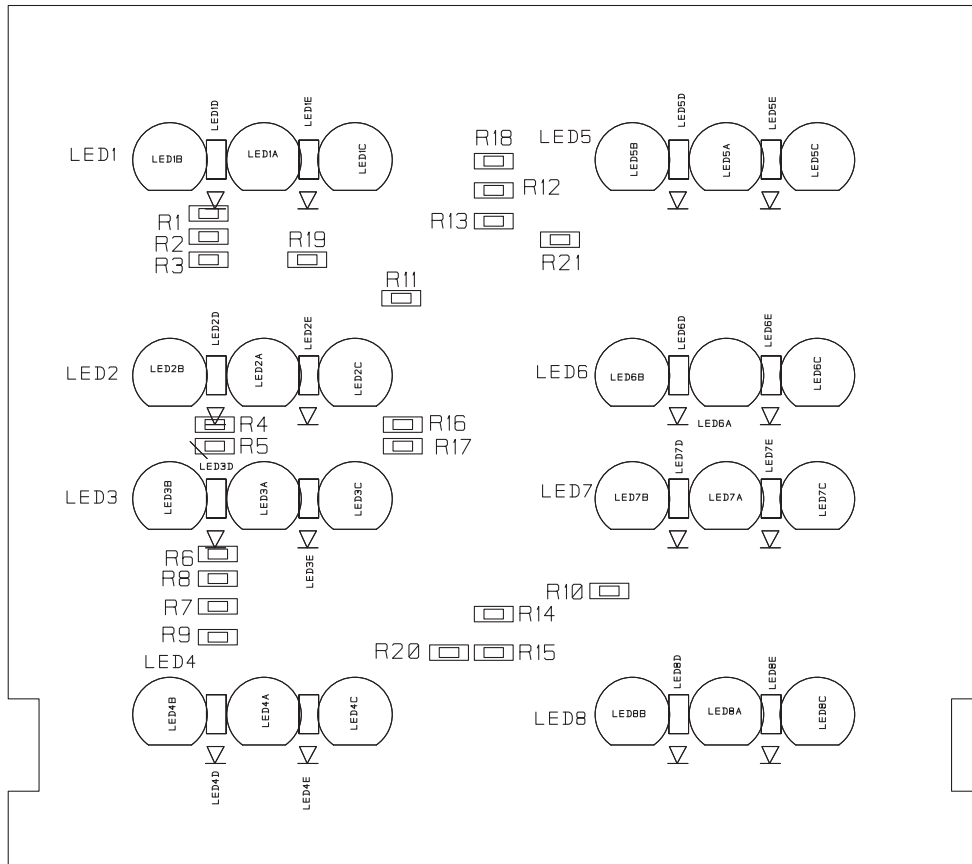

4 Point and all options shown for reference
Not all configurations have all of the displayed components.

Common Service Modules

The Common Service Module (CSM) is typically located in the lower right cell of the Annunciator System in card slot 1. It is used to provide common alarm outputs, perform flashing per selectable ISA Sequences and coordinate the pushbutton controls. One version CSM includes the Time Stamping of Alarms or Sequential Events Recorder (SER). The CSM has four common alarm outputs (2 standard and 2 optional) with relay operation configured via Software. All Annunciator software configuration is performed through the CSM serial port, accessible from the front of unit. The CSM module can be configured via jumpers for Form A or B Relay Contacts.

Relay output selection (LK1-4)

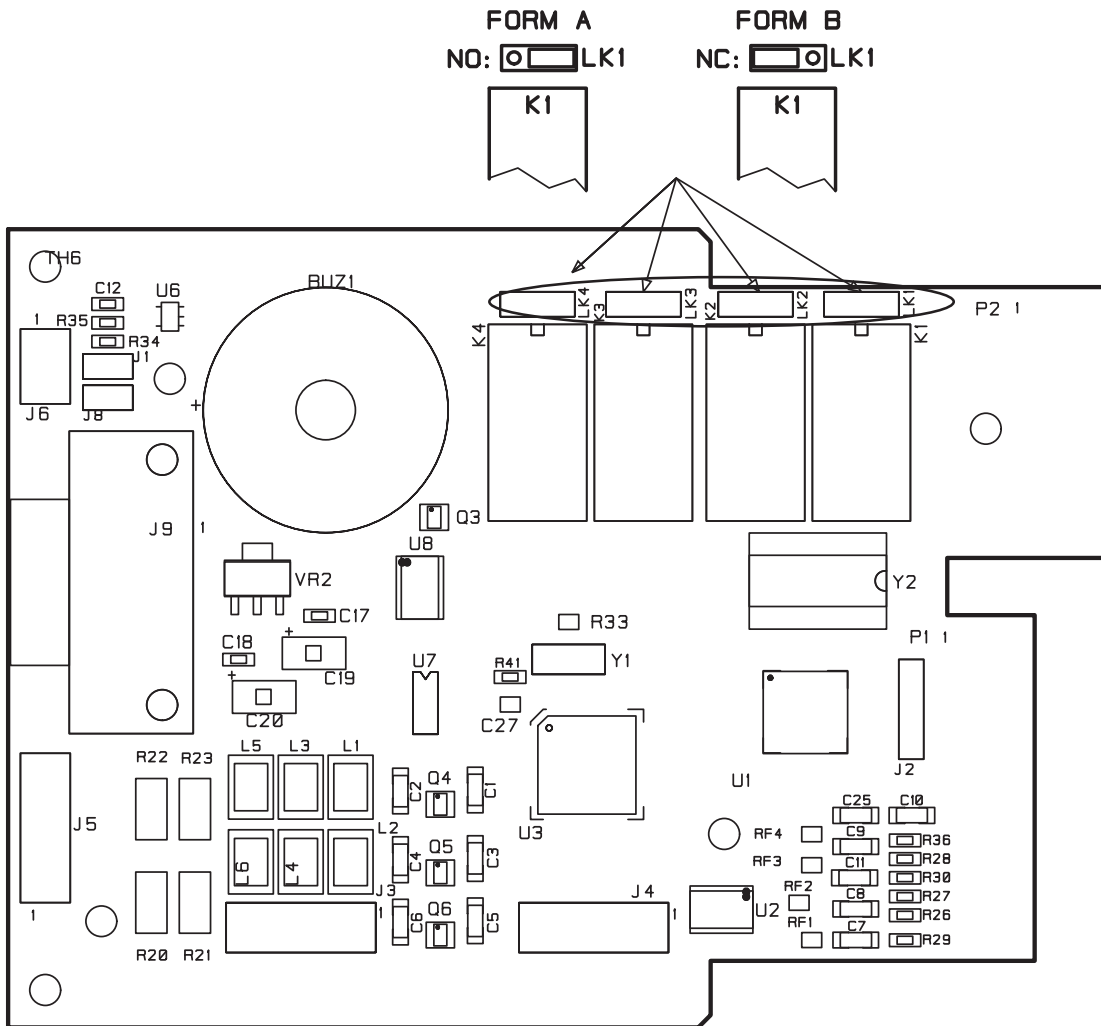

Communication Modules

The optional Communication Modules plug directly into the CSM Module through card slot 2 and provide either a serial or Ethernet output. Only one Communication Module per CSM is allowed.

Serial

The Serial Communication Module provides RS-232/485 serial data output or inputs via Modbus or DNP protocols. When used with the SER CSM, it can be used to provide an output of time stamped alarms in ASCII format in addition to Modbus or DNP. The Serial Communication Module can be configured via jumpers for RS-232/485 communications. It can be configured via software for all Modbus and DNP settings.

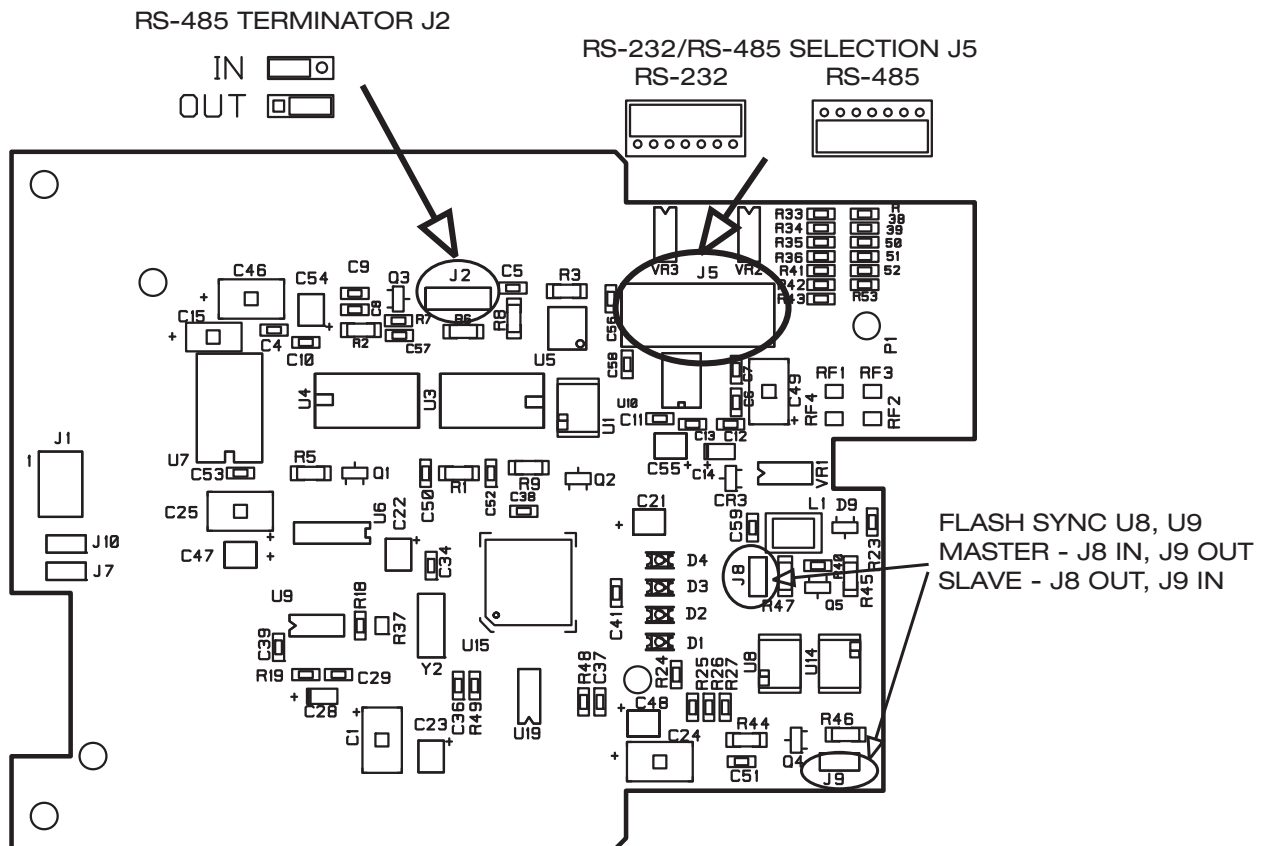

Ethernet

The Ethernet Communication Module has no configuration jumpers. When installed this module is mounted onto the Common Service module and together they are installed in slot 1 and 2,

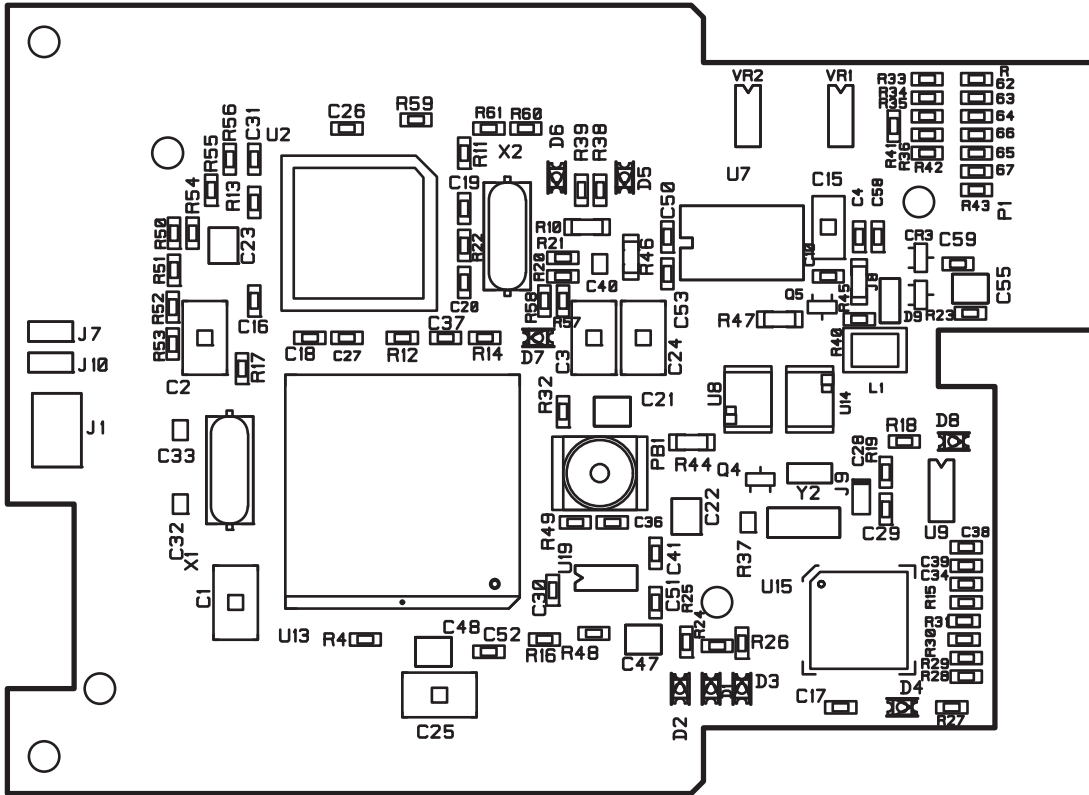

Ground Fault Detector Module

The optional Ground Fault Detector Module can be installed in Card Slot 5 of any cell that does not contain an Integral Power Supply or IRIG-B Module. It can be calibrated for sensitivity via the front. The Ground Fault Detector has jumpers selectable for the Field Contact Voltage used within the system. It only operates with 24, 48 or 125VDC.

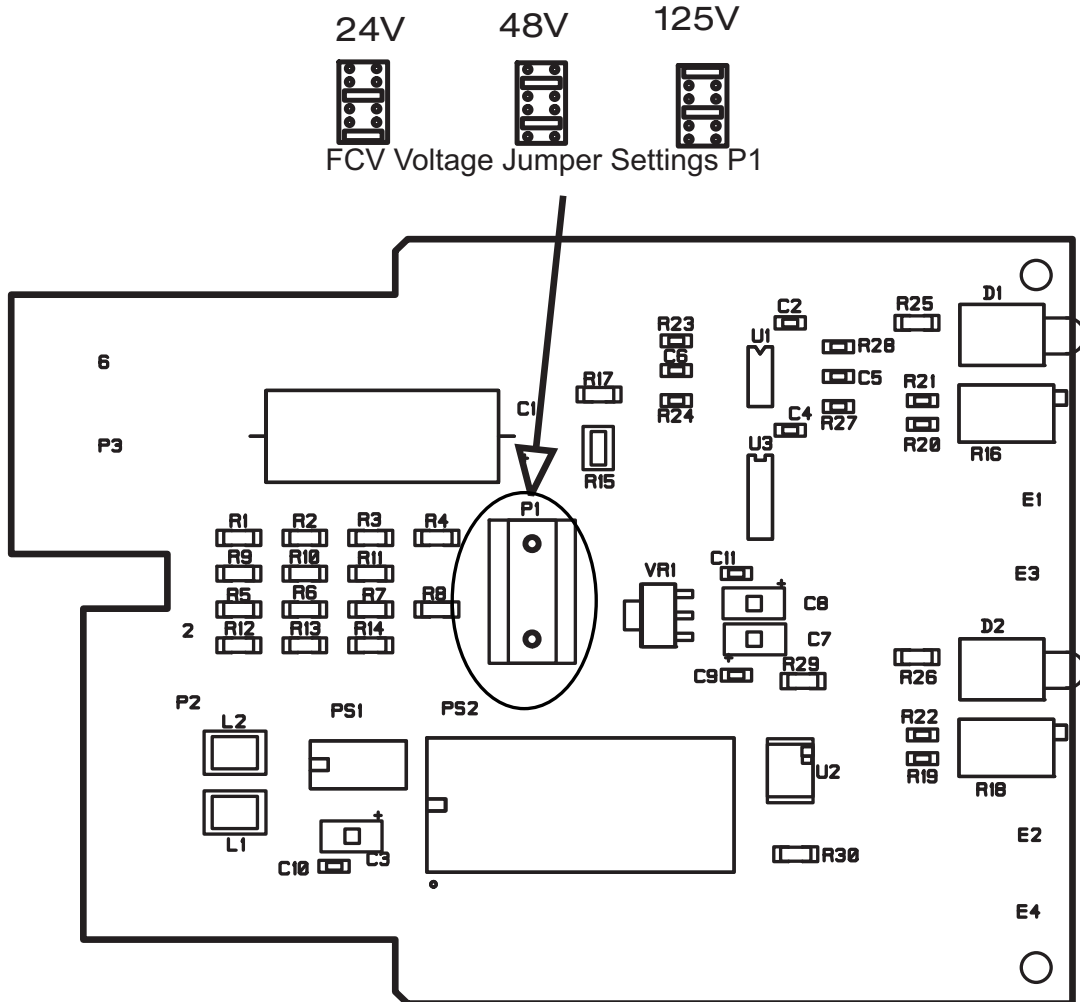

Power Supply Modules

Several Integral Power Supply Modules are available depending on the system input power, size of the system and field contact voltage selection. There are no configurable jumpers on these modules. Refer to the power connection in this manual for the power supply images.

Field Contact Voltage Supply Modules

Several Integral FCV Supply Modules are available depending on the system input power and field contact voltage selection. There are no configurable jumpers on these modules. Refer to the power connection in this manual for the power supply images.

IRIG-B Module

The optional IRIG-B Module is used for External time synchronization of the SER Option. This must be installed in Card Slot 5 of the CSM Cell. (When used, the Integral Power Supply must be moved to a different cell.)

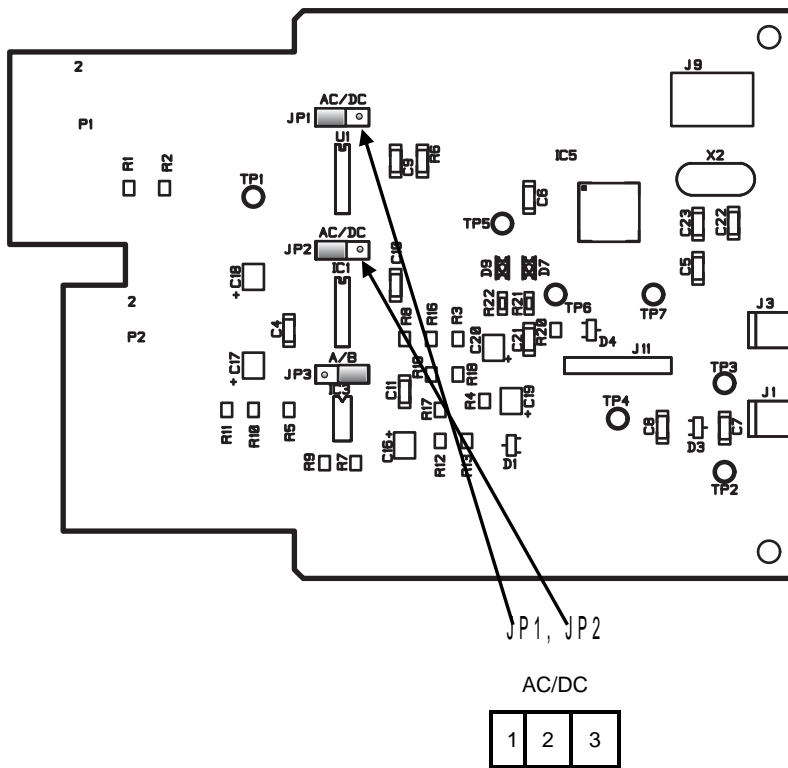

IRIG-B MODULE SETUP

	Jumper Position			INPUT TYPE
	1	2	3	
JP1	1	2	3	Modulated(AC)
JP2	1	2	3	
JP1	1	2	3	Demodulated (DC)
JP2	1	2	3	

INSTALLATION

MOUNTING

The system is designed for Panel Mounting and 19" Rack Mounting, Other mounting methods such as NEMA Enclosures and Surface or Wall Mounting will have additional details and drawings provided by the factory.

Caution must be exercised when installing this, or any other type of equipment into racks or panels. Ensure that all equipment is properly secured using the specified hardware in accordance with equipment manufacturer's specifications.

Panel Mounting (option PM, PC)

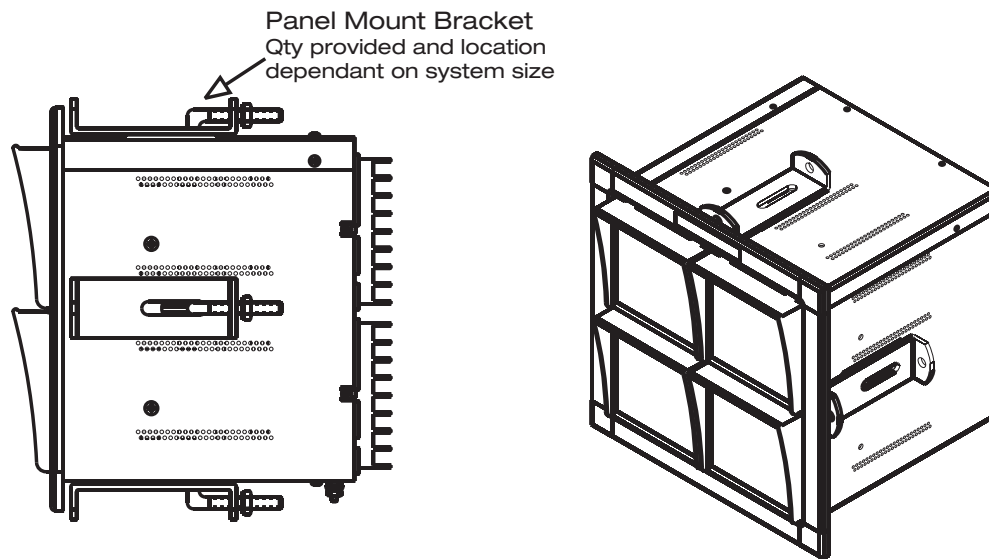

The dimensions given in the tables below refer to the size of the panel cut out required for mounting and the front bezel height and width. The height and width are related to the number of cells in the system. Dimensions shown are in inches (mm).

# of Cells High	# of Cells Wide	Overall Height or Overall Width	Panel Cut-Out Height or Panel Cut-Out Width
1	---	5.0 (127)	4.06 (103)
2	2	8.47 (215)	7.53 (191)
3	3	11.94 (303)	11.0 (279)
4	4	15.40 (391)	14.47 (368)
5	5	18.88 (479)	17.94 (456)
6	6	22.34 (568)	21.41 (544)
7	7	25.81 (656)	24.88 (632)
8	8	29.28 (744)	28.34 (720)
9	9	32.75 (832)	31.81 (808)
10	10	36.22 (920)	35.28 (896)
11	11	39.69 (1008)	38.75 (984)
12	12	43.16 (1096)	42.22 (1072)
13	13	46.63 (1184)	45.69 (1161)

Tolerance on all cut out dimensions is 0.0625 inches (1.5mm)

Example: A 3H x 4W Annunciator has a cutout height of 11.0 and a cutout width of 14.47.

Annunciator Depth (Behind Panel)	Inches	Mm
Maximum depth w/out rear cover	6.75	171
Maximum depth w/ rear cover	10.00	254

Minimum mounting panel thickness: 18 GA Galvanneal, 0.072 inches, 1.83 mm.

For system installation perform the following steps:

- 1 Mark cutout dimensions on the surface where the annunciator is to be mounted, keeping in mind that the assembly may rest on the sill of the cutout.

NOTE: Allow a minimum of 6 inches (150 mm) above the unit and behind the panel for proper ventilation.
- 2 Cut out and remove panel material.
- 3 Temporally remove the panel mounting clamps and Install the annunciator assembly through the panel cut-out (from the front of the panel). Position the annunciator within the cut-out so that the weight is taken at the bottom of the unit.
- 4 From the rear of the panel, replace the annunciator mounting clamps along the bottom then top and sides screws to “finger tight” check the front of panel alignment on panel face etc
- 5 Fully tighten the mounting clamps.

19" Rack Mounting (option RK)

The dimensions given in the tables below refer to the height of the 19" Rack based on the number of Cells High. In all configurations, the Annunciator will be 5 cells wide to maintain the 19" rack width. Dimensions shown are in inches (mm)

# of Cells High	Overall Rack Height		
	Inches	mm	U Rack
1	5.25	133.35	3U
2	8.75	222.25	5U
3	12.25	311.15	7U
4	15.75	400.05	9U
5	19.25	488.95	11U
6	22.75	577.85	13U
7	26.25	666.75	15U
8	29.75	755.65	17U
9	33.25	844.55	19U
10	36.75	933.45	21U
11	40.25	1022.35	23U
12	43.75	1111.25	25U
13	47.25	1200.15	27U

Annunciator Depth	Inches	mm
Maximum depth	6.8	172.72

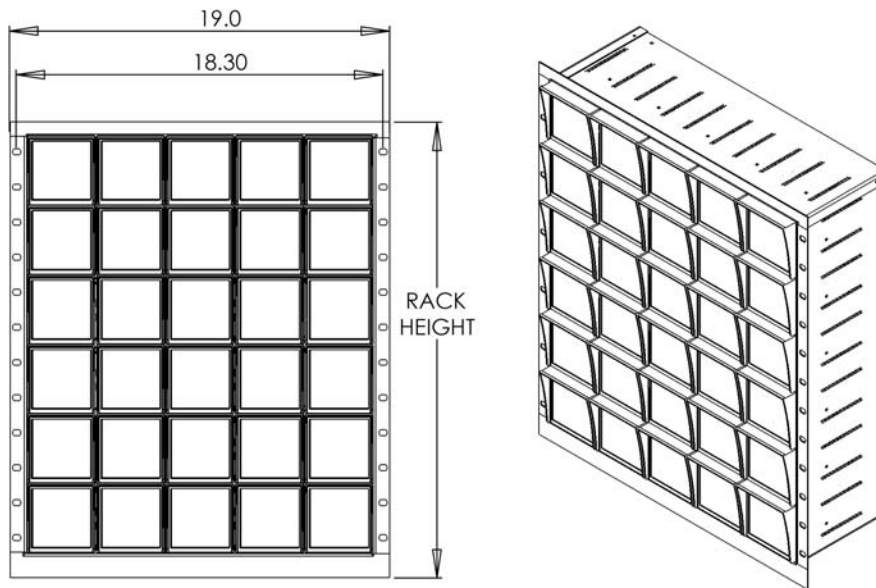

For system installation, perform the following steps:

Allow a minimum of 6 inches (150 mm) above the unit and behind the panel for proper ventilation.

- 1 Slide the annunciator assembly into the rack (from the front of the rack).
- 2 Secure using the recommended fixing screws into the rack mount rails.

NEMA Enclosure (option N4, N4PB)

The dimensions given in the chart below are for both options (N4, N4PB). Only the N4 is shown. Both options may also include a horn mounted on the face of the door. The Annunciator is mounted on a swing frame behind the door and is viewed through a window installed in the door. The swing frame allows access to the wiring behind the Annunciator.

Caution: In order to prevent tipping, the NEMA enclosure must be securely fastened to a surface before attempting to open the door or the swing panel.

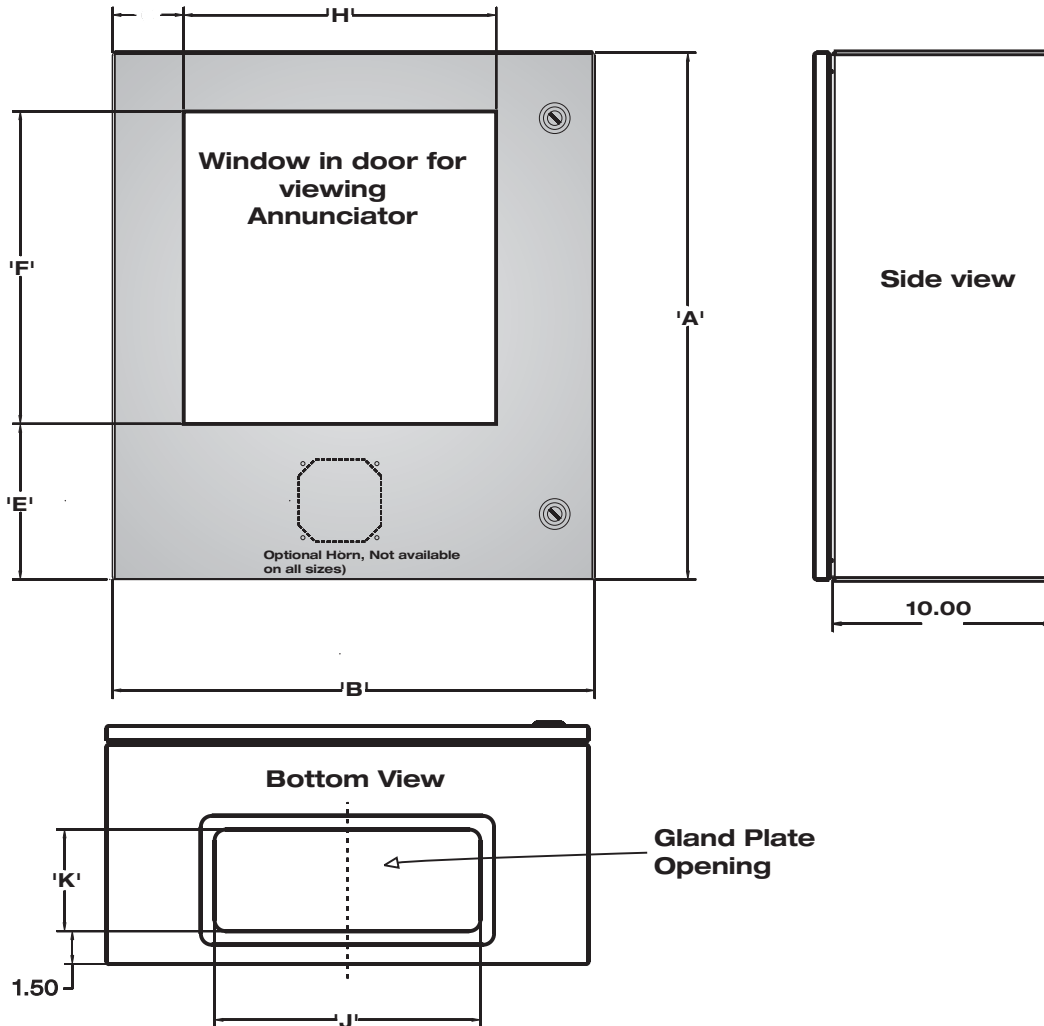

PART #	A	B	E	F	G	H	J	K
1 or 2 H X 3 or 4W	16.00	22.00	6.03	7.32	3.25	14.25	12.13	4.63
1 or 2 H X 5 or 6W	16.00	30.00	6.03	7.32	4.31	21.19	12.13	4.63
1 or 2 H X 7 or 8W	16.00	36.00	5.63	7.32	3.47	28.03	19.63	4.63
3 or 4 H X 3 or 4W	24.00	22.00	7.09	14.25	3.25	14.25	12.13	4.63
3 or 4 H X 5 or 6W	24.00	30.00	7.09	14.25	4.31	21.19	12.13	4.63
3 or 4 H X 7 or 8W	24.00	36.00	6.75	14.25	3.47	28.03	19.63	4.63
5 or 6 H X 3 or 4W	32.00	22.00	8.15	21.19	3.25	14.25	12.13	4.63
5 or 6 H X 5 or 6W	32.00	30.00	8.15	21.19	4.31	21.19	12.13	4.63
5 or 6 H X 7 or 8W	32.00	36.00	7.75	21.19	3.47	28.03	19.63	4.63

Surface (Wall) Mounting (option S)

Mounting to a wall or other surface. The annunciator is hinged on one side to allow access to the terminal blocks in the rear of the unit. The hinge may be moved to the right side of the annunciator by removing the brackets, rotating them and re-mounting them to the opposite side(s). Refer to table for available sizes and dimensions. All mounting holes sized for ¼ -20 hardware.

A minimum of 10" of swing clearance is required on the hinge side of the annunciator.

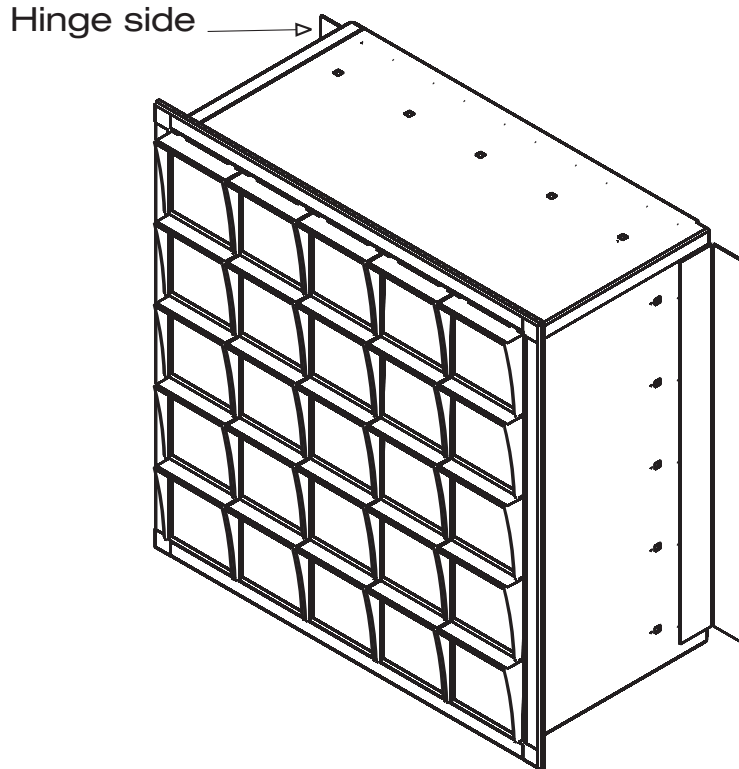

Refer to the following chart and the figures on the following page for mounting dimensions.

Dimension	ANNUNCIATOR SIZE										Dimension
	1H	2H	3H	4H	5H	2W	3W	4W	5W		
A	3.65	7.12	10.59	14.06	17.53	X					
B	4.93	8.40	11.87	15.34	18.81						
C	0.40	1.12	1.12	1.12	1.12						
D	1.90	4.59	4.59	4.59	4.59						
E	-----	-----	8.05	8.05	8.05						
F	-----	-----	-----	11.52	11.52						
G	-----	-----	-----		14.99						
H	2.23	5.70	9.17	12.64	16.11						
	X					8.74	12.21	15.68	19.15	J	
						8.39	11.86	15.33	18.80	K	
						10.24	13.71	17.18	20.65	L	

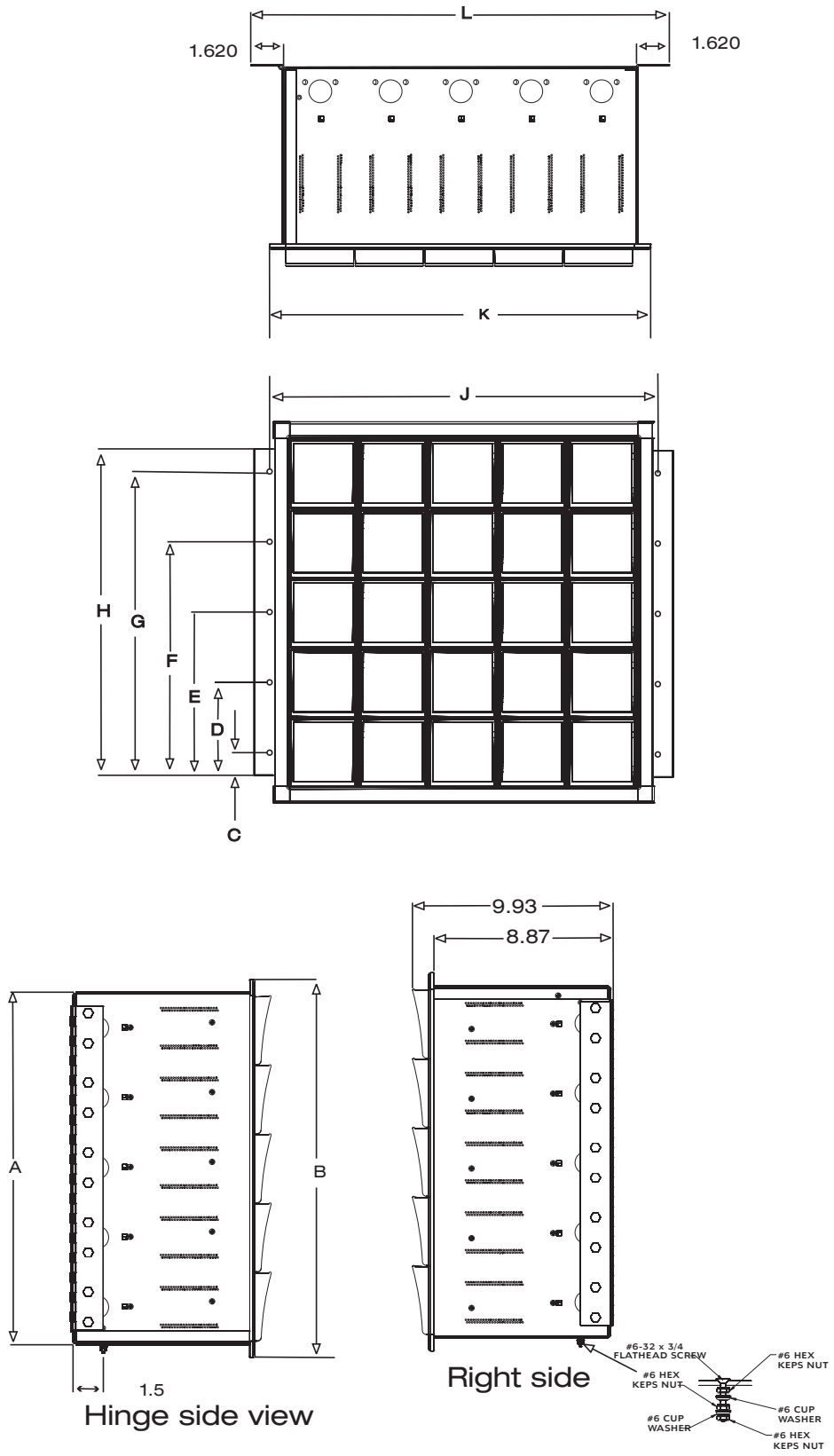

Weather Tight NEMA Front Cover (option NCB, NCT)

This option provides for a NEMA rated front cover for the panel-mounted option, it consists of a swing frame and a weather tight door. Two options are available; the NCB option uses $\frac{1}{4}$ bolts to secure the door to the panel; the NCT option has a T-Handle for securing the door. Both options use $\frac{1}{4}$ -20 mounting bolts to secure the swing panel to the mounting surface. Refer to the charts following for the mounting hole location and over-all size of the door.

Refer to the Panel mount option for the cut-out dimensions for the annunciator, mount the door option, centered on the hole. Mount the annunciator thru the panel hole and secure with the mounting clamps as described in the panel mount installation instructions (option PM, PC)

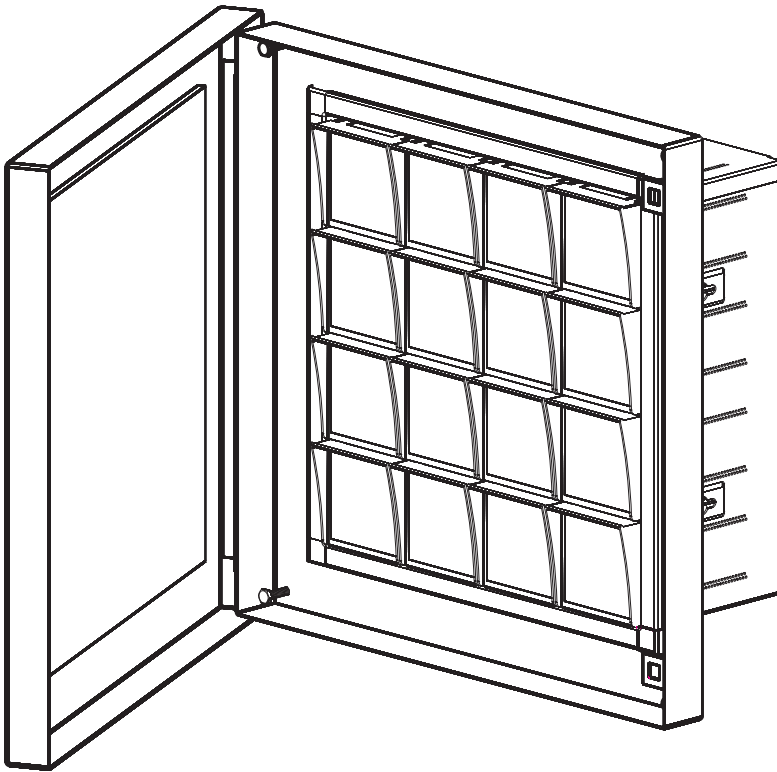

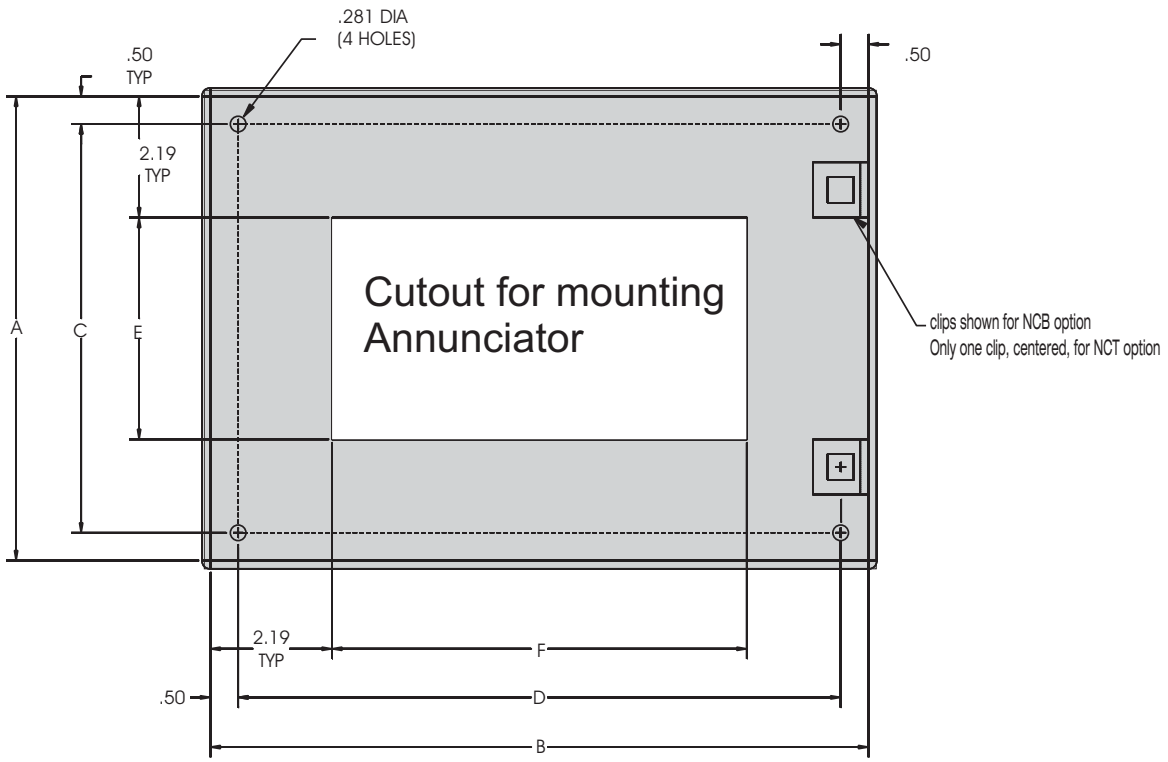

# OF CELLS HIGH	# OF CELLS WIDE	DIM A	DIM B	DIM C	DIM D	DIM E	DIM F
1	2	8.38	11.84	7.38	10.84	4.00	7.47
1	3	8.38	15.31	7.38	14.31	4.00	10.94
1	4	8.38	18.78	7.38	17.78	4.00	14.41
1	5	8.38	22.25	7.38	21.25	4.00	17.88
1	6	8.38	25.72	7.38	24.72	4.00	21.34
1	7	8.38	29.19	7.38	28.19	4.00	24.81
1	8	8.38	32.66	7.38	31.66	4.00	28.28
1	9	8.38	36.13	7.38	35.13	4.00	31.75
1	10	8.38	39.59	7.38	38.59	4.00	35.22
2	2	11.84	11.84	10.84	10.84	7.47	7.47
2	3	11.84	15.31	10.84	14.31	7.47	10.94
2	4	11.84	18.78	10.84	17.78	7.47	14.41
2	5	11.84	22.25	10.84	21.25	7.47	17.88
2	6	11.84	25.72	10.84	24.72	7.47	21.34
2	7	11.84	29.19	10.84	28.19	7.47	24.81
2	8	11.84	32.66	10.84	31.66	7.47	28.28
2	9	11.84	36.13	10.84	35.13	7.47	31.75
2	10	11.84	39.59	10.84	38.59	7.47	35.22
3	2	15.31	11.84	14.31	10.84	10.94	7.47
3	3	15.31	15.31	14.31	14.31	10.94	10.94
3	4	15.31	18.78	14.31	17.78	10.94	14.41
3	5	15.31	22.25	14.31	21.25	10.94	17.88
3	6	15.31	25.72	14.31	24.72	10.94	21.34
3	7	15.31	29.19	14.31	28.19	10.94	24.81
3	8	15.31	32.66	14.31	31.66	10.94	28.28
3	9	15.31	36.13	14.31	35.13	10.94	31.75
3	10	15.31	39.59	14.31	38.59	10.94	35.22

# OF CELLS HIGH	# OF CELLS WIDE	DIM A	DIM B	DIM C	DIM D	DIM E	DIM F
4	2	18.78	11.84	17.78	10.84	14.41	7.47
4	3	18.78	15.31	17.78	14.31	14.41	10.94
4	4	18.78	18.78	17.78	17.78	14.41	14.41
4	5	18.78	22.25	17.78	21.25	14.41	17.88
4	6	18.78	25.72	17.78	24.72	14.41	21.34
4	7	18.78	29.19	17.78	28.19	14.41	24.81
4	8	18.78	32.66	17.78	31.66	14.41	28.28
4	9	18.78	36.13	17.78	35.13	14.41	31.75
4	10	18.78	39.59	17.78	38.59	14.41	35.22
5	2	22.25	11.84	21.25	10.84	17.88	7.47
5	3	22.25	15.31	21.25	14.31	17.88	10.94
5	4	22.25	18.78	21.25	17.78	17.88	14.41
5	5	22.25	22.25	21.25	21.25	17.88	17.88
5	6	22.25	25.72	21.25	24.72	17.88	21.34
5	7	22.25	29.19	21.25	28.19	17.88	24.81
5	8	22.25	32.66	21.25	31.66	17.88	28.28
5	9	22.25	36.13	21.25	35.13	17.88	31.75
5	10	22.25	39.59	21.25	38.59	17.88	35.22
6	2	25.72	11.84	24.72	10.84	21.34	7.47
6	3	25.72	15.31	24.72	14.31	21.34	10.94
6	4	25.72	18.78	24.72	17.78	21.34	14.41
6	5	25.72	22.25	24.72	21.25	21.34	17.88
6	6	25.72	25.72	24.72	24.72	21.34	21.34
6	7	25.72	29.19	24.72	28.19	21.34	24.81
6	8	25.72	32.66	24.72	31.66	21.34	28.28
6	9	25.72	36.13	24.72	35.13	21.34	31.75
6	10	25.72	39.59	24.72	38.59	21.34	35.22
7	2	29.19	11.84	28.19	10.84	24.81	7.47
7	3	29.19	15.31	28.19	14.31	24.81	10.94
7	4	29.19	18.78	28.19	17.78	24.81	14.41
7	5	29.19	22.25	28.19	21.25	24.81	17.88
7	6	29.19	25.72	28.19	24.72	24.81	21.34
7	7	29.19	29.19	28.19	28.19	24.81	24.81
7	8	29.19	32.66	28.19	31.66	24.81	28.28
7	9	29.19	36.13	28.19	35.13	24.81	31.75
7	10	29.19	39.59	28.19	38.59	24.81	35.22
8	2	32.66	11.84	31.66	10.84	28.28	7.47
8	3	32.66	15.31	31.66	14.31	28.28	10.94
8	4	32.66	18.78	31.66	17.78	28.28	14.41
8	5	32.66	22.25	31.66	21.25	28.28	17.88
8	6	32.66	25.72	31.66	24.72	28.28	21.34
8	7	32.66	29.19	31.66	28.19	28.28	24.81
8	8	32.66	32.66	31.66	31.66	28.28	28.28
8	9	32.66	36.13	31.66	35.13	28.28	31.75
8	10	32.66	39.59	31.66	38.59	28.28	35.22
9	2	36.13	11.84	35.13	10.84	31.75	7.47
9	3	36.13	15.31	35.13	14.31	31.75	10.94
9	4	36.13	18.78	35.13	17.78	31.75	14.41
9	5	36.13	22.25	35.13	21.25	31.75	17.88
9	6	36.13	25.72	35.13	24.72	31.75	21.34
9	7	36.13	29.19	35.13	28.19	31.75	24.81
9	8	36.13	32.66	35.13	31.66	31.75	28.28
9	9	36.13	36.13	35.13	35.13	31.75	31.75

# OF CELLS HIGH	# OF CELLS WIDE	DIM A	DIM B	DIM C	DIM D	DIM E	DIM F
9	10	36.13	39.59	35.13	38.59	31.75	35.22
10	2	102	102	102	102	102	102
10	3	39.59	15.31	38.59	14.31	35.22	10.94
10	4	39.59	18.78	38.59	17.78	35.22	14.41
10	5	39.59	22.25	38.59	21.25	35.22	17.88
10	6	39.59	25.72	38.59	24.72	35.22	21.34
10	7	39.59	29.19	38.59	28.19	35.22	24.81
10	8	39.59	32.66	38.59	31.66	35.22	28.28
10	9	39.59	36.13	38.59	35.13	35.22	31.75
10	10	39.59	39.59	38.59	38.59	35.22	35.22

External Power Supply Mounting

An external Power Supply is available for 120/230VAC Power and one is available for 125VDC Power also. These are used on larger systems per the power supply chart.

120/230VAC Power Supply

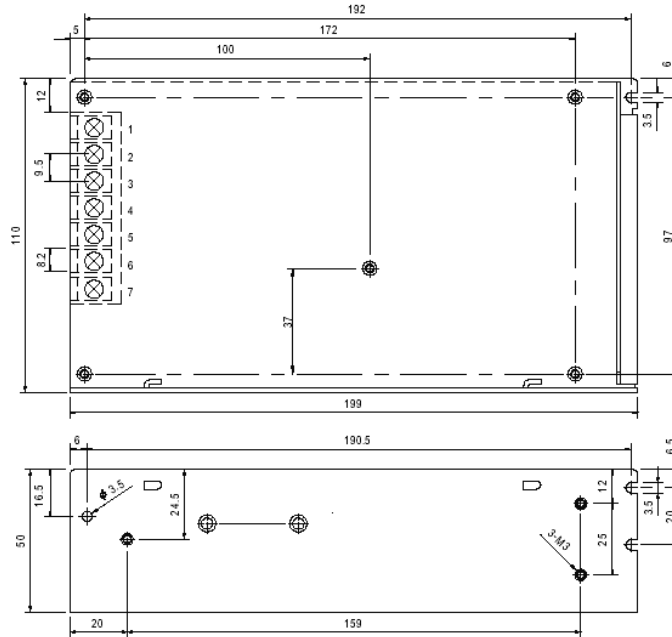

125VDC Power Supply

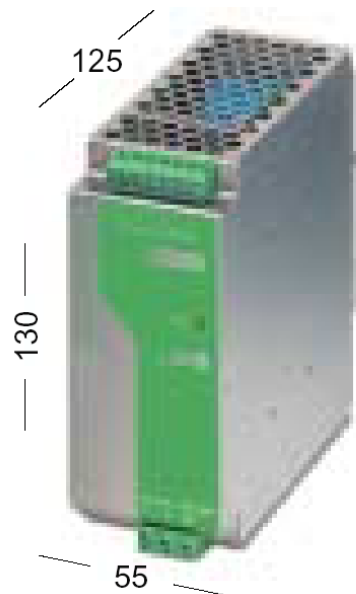

WIRING

All wiring connections are made to the rear of the unit using barrier style terminal blocks. All Field Contact Inputs, Relay Outputs and Power Connections are made to Terminal Blocks that have a #6 screw, which will accept a solid or stranded wire from 12-22 AWG, with or without ring & spade lugs. The Pushbutton Controls and Flash Synchronization connections are made to Terminal Blocks that have a #6 screw which will accept a solid or stranded wire from 14-22 AWG, with or without ring & spade lugs.

Ensure that a proper earth ground connection is made to the protective earth ground stud.



Note for Relay Output Wiring: When option RR (Repeat relay) is installed, and 120 Vac is switched by the contact. All output wiring in any individual cell must be wired to the same phase of the service.

Input Wiring

The input wiring is determined by the number of alarms (or windows per cell) and the number of I/O Cards. The available configurations are:

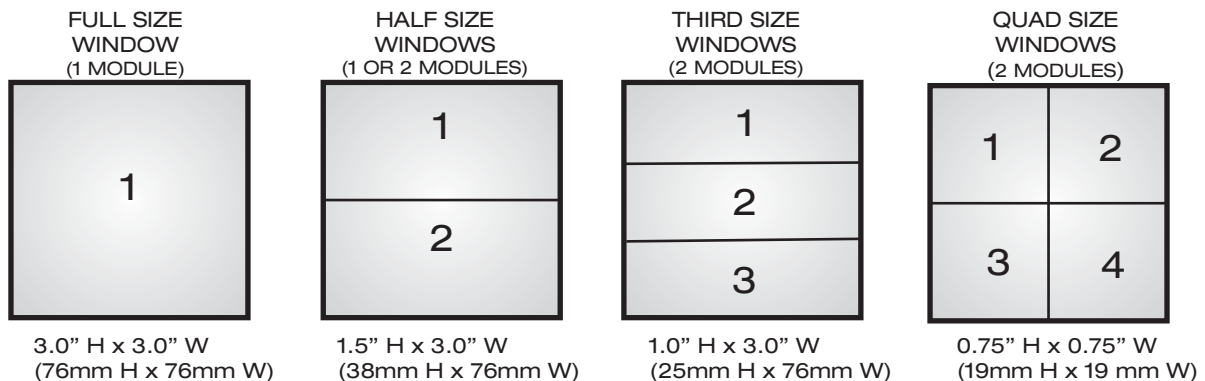

The I/O cards can support up to two inputs, however, certain options limit that to one input per card as shown with the Half Size Window above.

Common Field Contact Voltage

The I/O cards are typically set up for a common system-wide Field Contact Voltage (FCV). In this case, terminals 2 and 4 of each I/O Terminal Block are connected to the FCV, which is internally bussed throughout the system to the Power Supply Terminal Block, Terminal 3. As shown in the Power Supply Drawings, an external Field Contact Voltage Supply can be connected to the Power Supply Terminal Block for distribution throughout the system. In systems where the FCV is generated within the Annunciator, it is already distributed throughout the Annunciator. Each I/O card FCV connection is internally fused preventing any overload from the field. Removing an I/O card will disconnect the FCV at the terminal block for that card only.

Isolated Field Contact Voltage

The I/O cards can be jumpered to remove the system wide bussing and replace with an individual FCV connection per input. This is shown on the drawings as well.

Input / Relay Wiring for Full Size Windows (using one I/O Card)

Model Code Window Size 1E



(Front View)

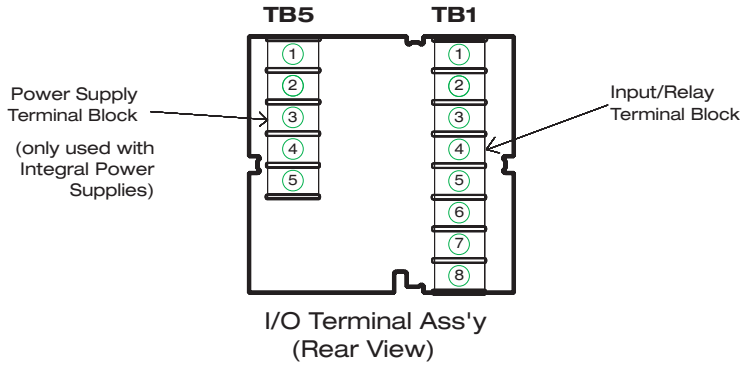

I/O Terminal Ass'y
(Rear View)

INPUT WIRING Common FCV

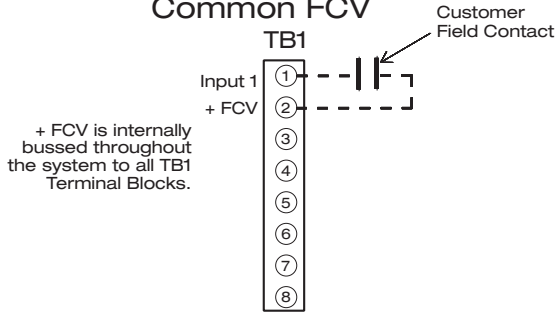

INPUT WIRING Isolated FCV

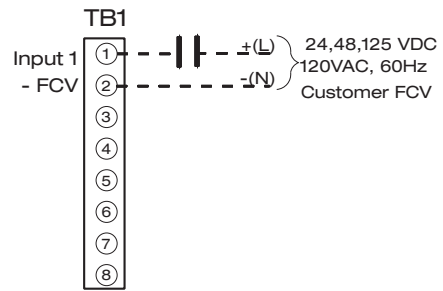

REPEAT RELAY WIRING Option RR and 2RR

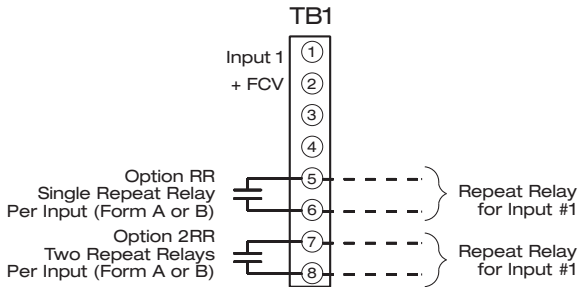

REPEAT RELAY WIRING Option FRC

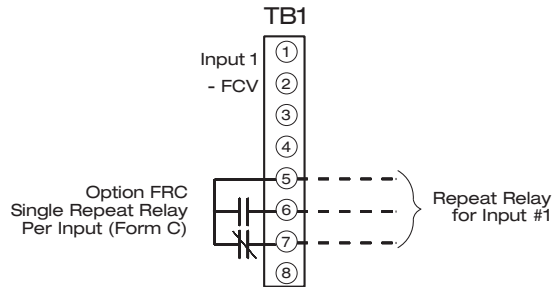

Input/Relay Wiring For Half Size Windows (using one I/O Card)

Model Code
Window Size 2



(Front View)

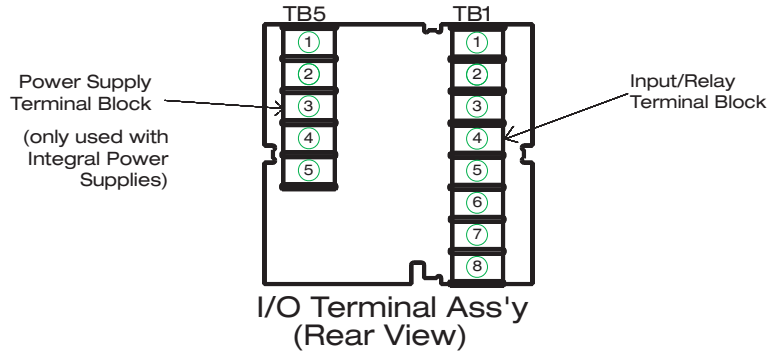

INPUT WIRING Common FCV

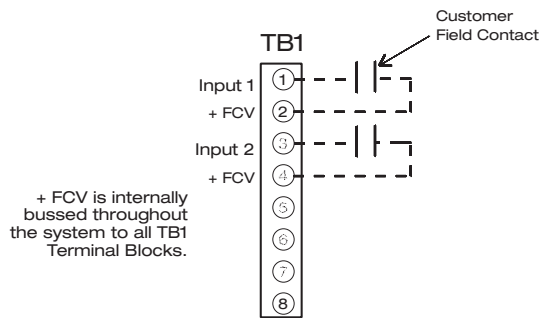

INPUT WIRING Isolated FCV

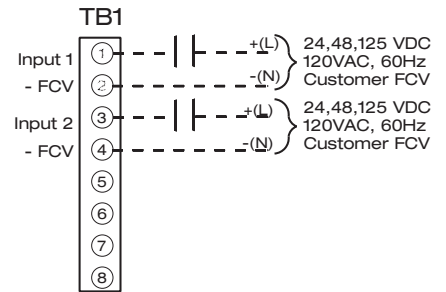

REPEAT RELAY WIRING Option RR

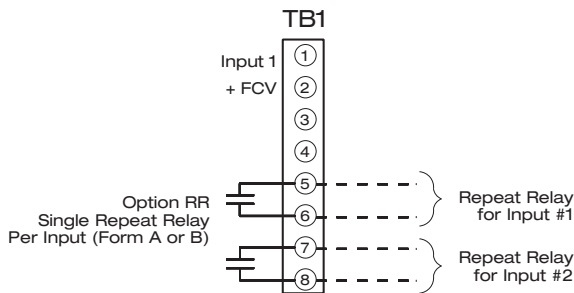

Input/Relay Wiring For Half Size Windows (using one I/O Card)

Model Code
Window Size 2E



(Front View)

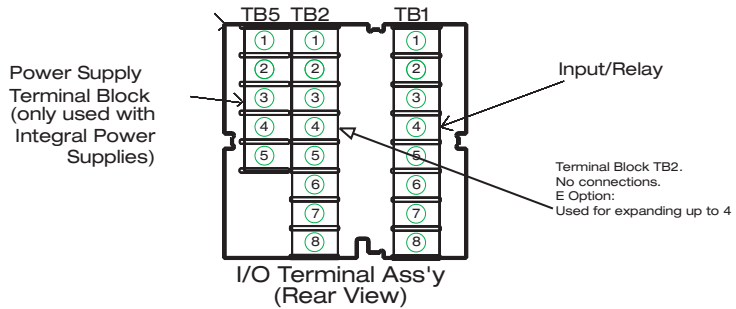

INPUT WIRING Common FCV

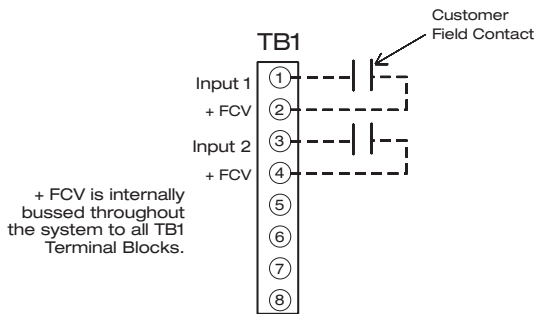

INPUT WIRING Isolated FCV

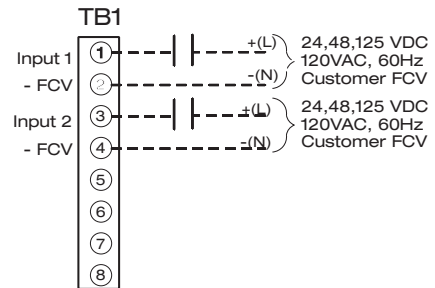

REPEAT RELAY WIRING Option RR

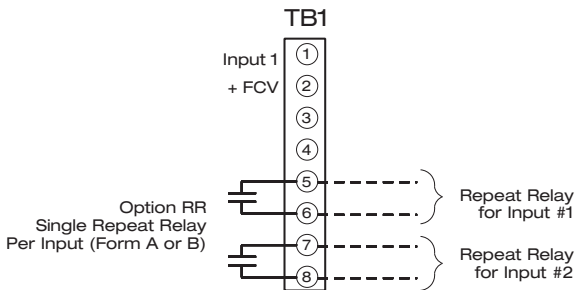

Input Wiring with Half Size Windows

Model Code
Window Size 2S

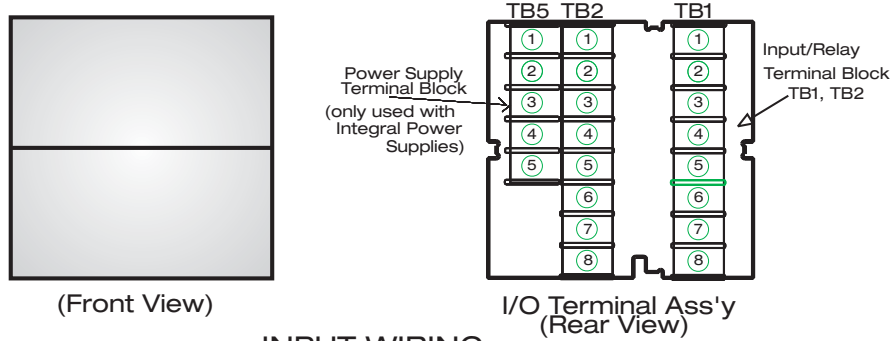

INPUT WIRING Common FCV

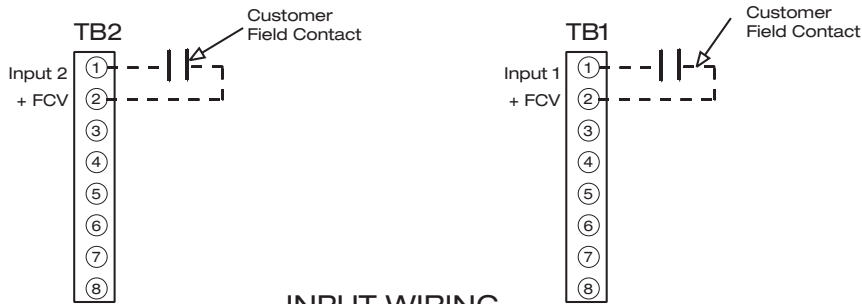

INPUT WIRING Isolated FCV

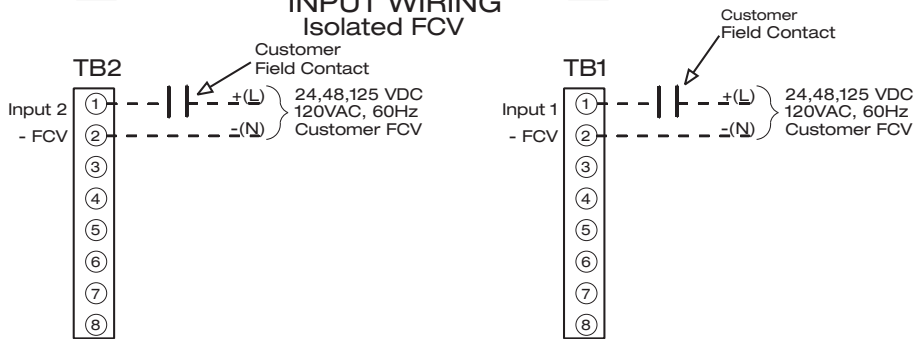

(using two I/O Cards)

Repeat Relay Wiring for Half Size Windows (using two I/O Cards)

Model Code
Window Size 2S

REPEAT RELAY WIRING

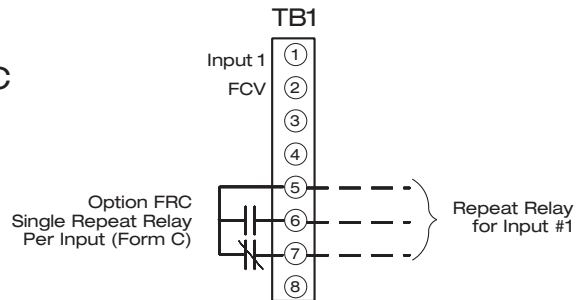
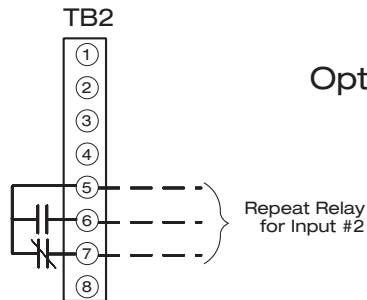
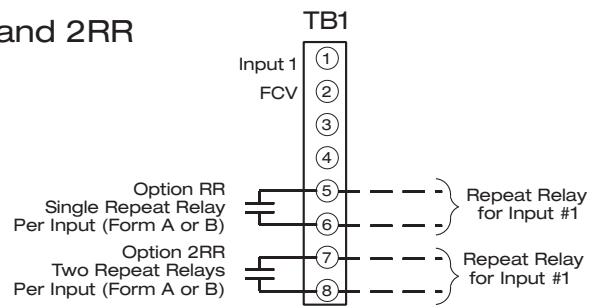
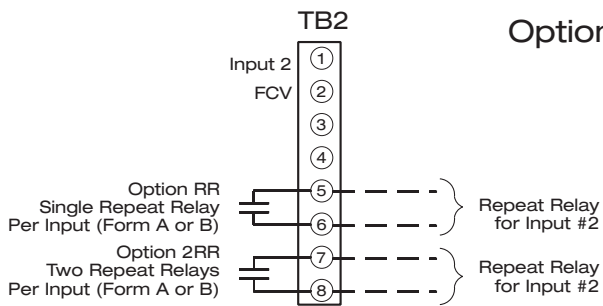
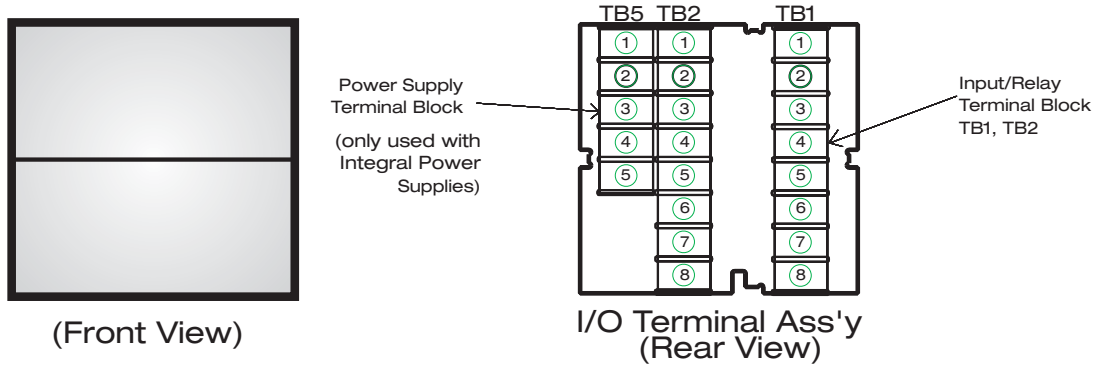

Input/Relay Wiring for Third Size Windows
(using two I/O Cards)

Model Code
 Window Size 3

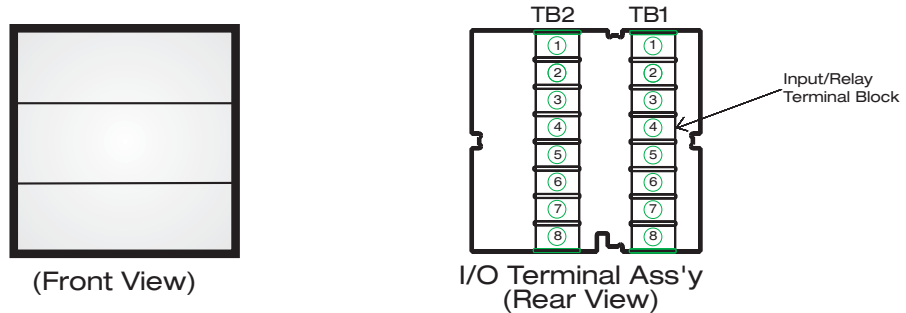

INPUT WIRING
 Common FCV

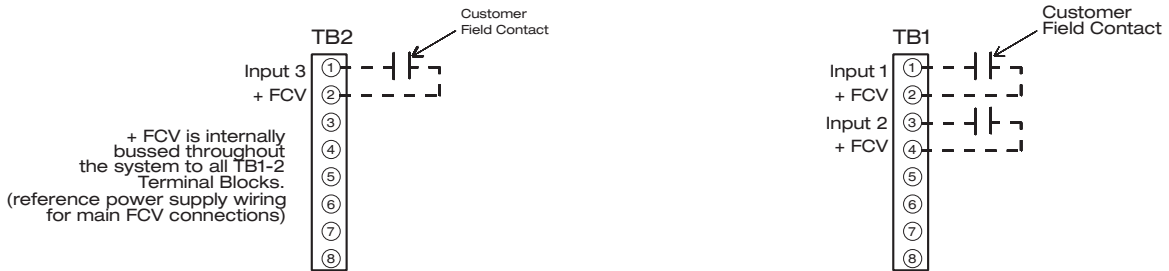

INPUT WIRING
 Isolated FCV

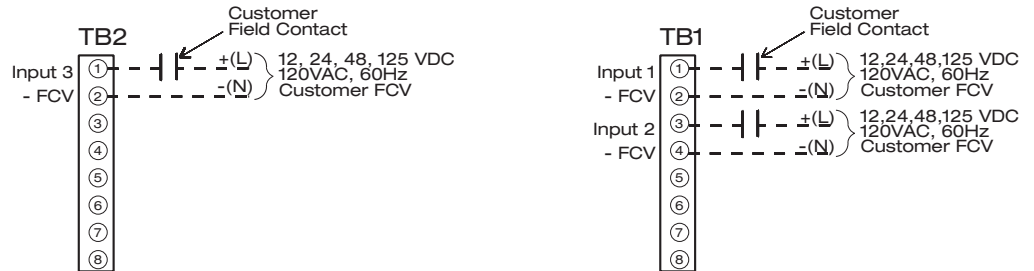

REPEAT RELAY WIRING
 Option RR

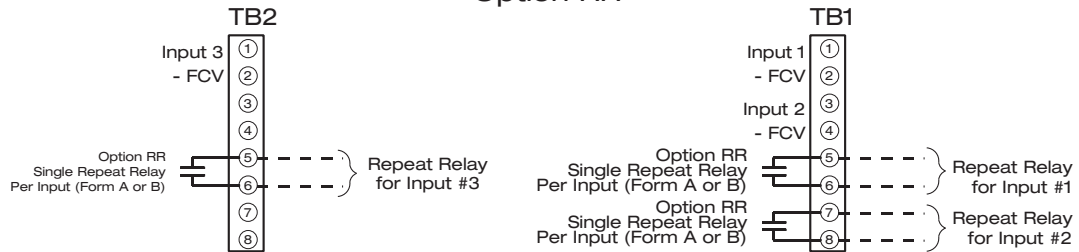

Input/Relay Wiring for Quad Size Windows (using two I/O Cards)

Model Code
Window Size 4

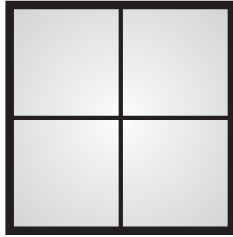

(Front View)

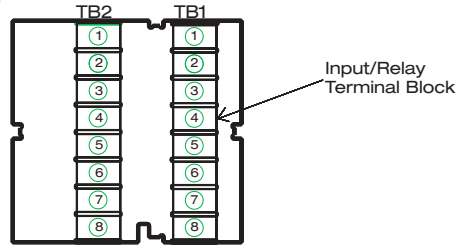

I/O Terminal Ass'y
(Rear View)

INPUT WIRING Common FCV

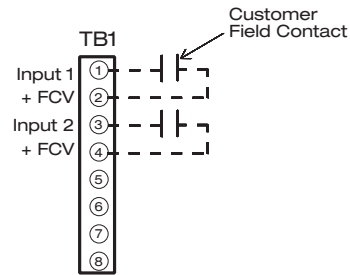
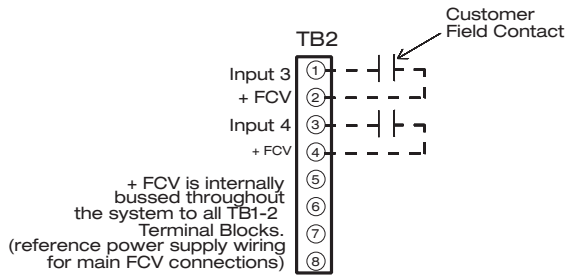

INPUT WIRING Isolated FCV

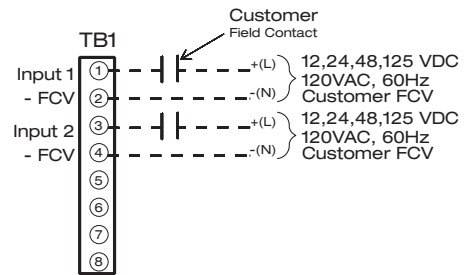
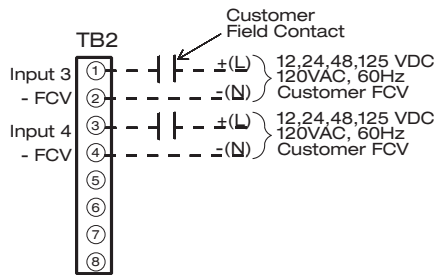

REPEAT RELAY WIRING Option RR

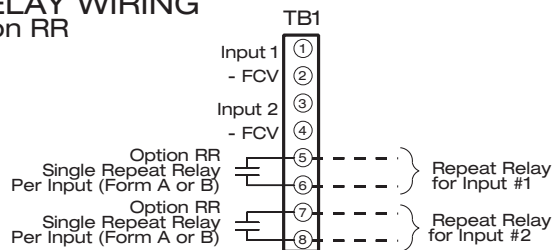
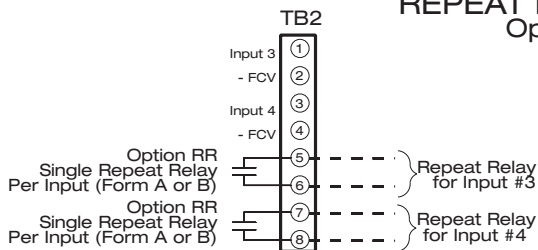

Common Service Cell Wiring (with Integral Pushbuttons)

Model Code
INTB

Integral Pushbuttons

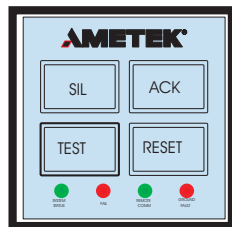

(front view)

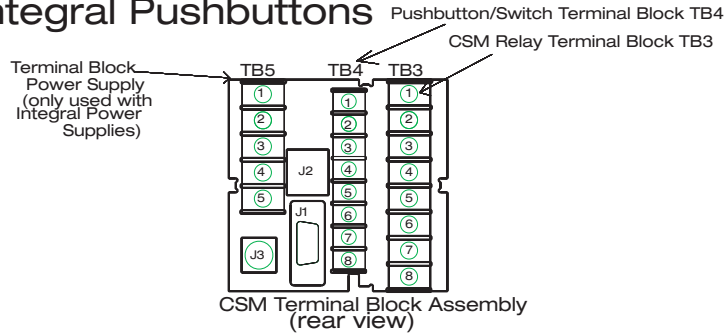

CSM WIRING

Common Service Relay Wiring

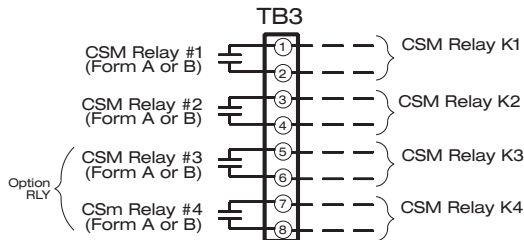

Pushbutton / Switch Wiring

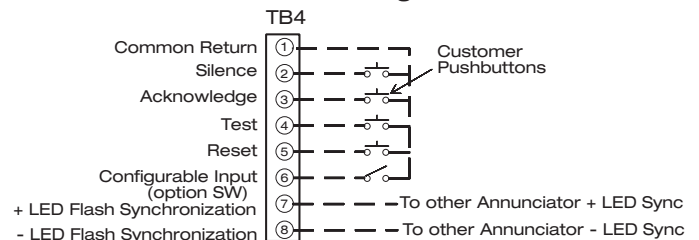

Note: TB4-7 can be used as a second Configurable Input when the LED Flash Synchronization Option is not used.

Power Supply Wiring

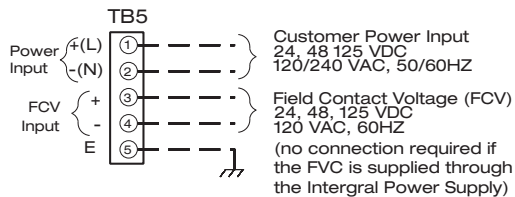

Communications Wiring

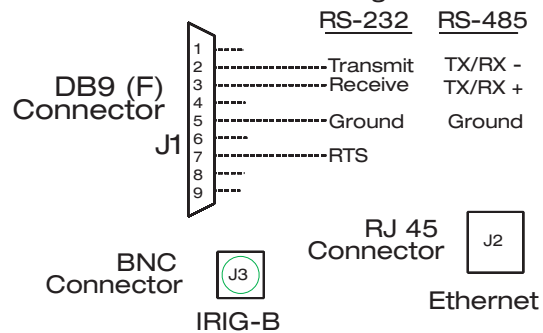

NOTE: When wiring an external horn or other audible device to the CSM output relays, it is recommended that the interconnect wires be physically isolated from any other input or output wiring.

Common Service Wiring (with I/O Modules)

Model Code

NPB

FULL SIZE WINDOW



HALF SIZE WINDOWS

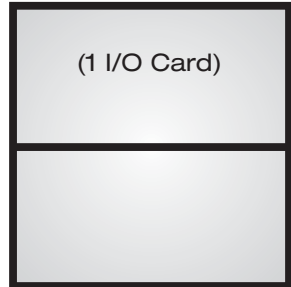

OR

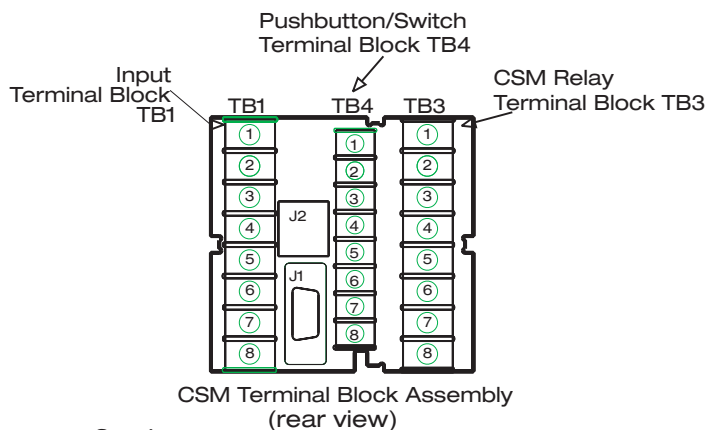

Common Service Relay Wiring

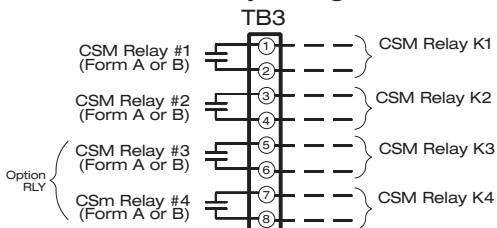

Pushbutton / Switch Wiring

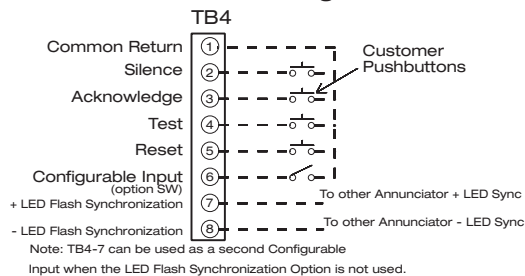

Input / Relay Wiring

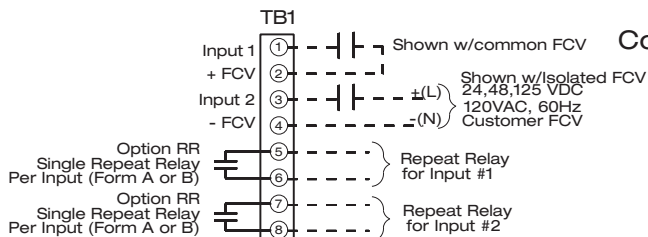

Communications Wiring

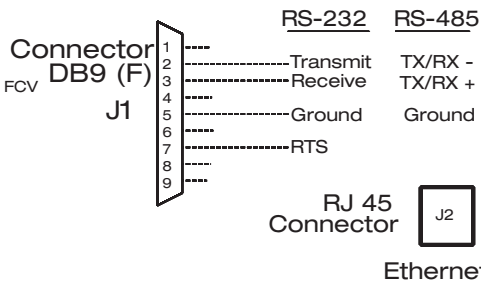

NOTE: When wiring an external horn or other audible device to the CSM output relays, it is recommended that the interconnect wires be physically isolated from any other input or output wiring.

CONNECTING POWER

The SERIES 90A Annunciator operates from a selection of AC and DC Voltages. The Annunciator uses Power Supplies to provide the necessary 5VDC Logic and LED Power. If the Field Contact Voltage (FCV) needs to be provided from the Annunciator, separate FCV Supplies are provided.

For 24 and 48 VDC Input Power, an Integral Power Supply will always be used. In some cases, multiple supplies will be located in the system to accommodate the quantity of inputs specified.

For 120/230 VAC and 125 VDC Input Power, the quantity of inputs, window sizes and other options determines whether the Power supplies can be self contained within the Annunciator (Integral Power Supply) or external to the Annunciator.

120/230 VAC & 125VDC Input Power

Annunciator Window Size	Integral Power Supply		External Power Supply	
	# of Inputs (with Repeat Relay option)	# of Inputs (without Repeat Relay option)	# of Inputs (with Repeat Relay option)	# of Inputs (without Repeat Relay option)
Full (1 per Cell)	1-25	1-30	>25	>30
Half (2 per Cell)	1-43	1-60	>43	>60
Third (3 per Cell)	1-56	1-90	>56	>90
Quad (4 per Cell)	1-60	1-100	>60	>100

The Field Contact Voltage (FCV) can be provided externally by the user or can be provided by the Field Contact Voltage Supply.

Field Contact Voltage

Customer Input Power	Customer Supplied 12, 24, 48, 125VDC	Annunciator Supplied Field Contact Voltage	
		24 VDC	125 VDC
24 VDC	X	X	X
48 VDC	X		
125 VDC	X	X	X
120 / 230 VAC	X	X	X

POWER REQUIREMENTS

External AC supply:

(Watts @ Annunciator power input per point)

Annunciator Window Size	I/O Cards with Repeat Relays	I/O Cards with no Repeat Relays
Full (1 per Cell)	1.7	1.4
Half (2 per Cell)	1.0	0.7
Third (3 per Cell)	0.7	0.4
Quad (4 per Cell)	0.7	0.4

Field Contact Voltage (FCV): 1.8 mA / point (nominal)

Integral AC supply:

(Watts @ Annunciator power input per point)

Annunciator Window Size	I/O Cards with Repeat Relays	I/O Cards with no Repeat Relays
Full (1 per Cell)	2.2	1.8
Half (2 per Cell)	1.3	0.8
Third (3 per Cell)	1.0	0.5
Quad (4 per Cell)	0.9	0.5

Field Contact Voltage (FCV): 1.8 mA / point (nominal)

Integral Power Supply

The Integral Power Supply is installed in slot 5 of the I/O or CSM Cell depending on the configuration and input power required. The Integral Power Supply provides a 5VDC output used for the Annunciator Logic and LED's. There are three different types of Integral Power Supplies available:

24VDC

48VDC

Universal 125VDC/120/230VAC.

Integral Power Supply Cell Locations

Customer Input Power	CSM Cell with Integral Pushbuttons	CSM Cell with one I/O Module	I/O Cell with one I/O Module	I/O Cell with two I/O Modules
24 VDC	X	X	X	X
48 VDC	X	X	X	X
125 VDC or 120/230 VAC	X		X	

Based on the size of the system, there could be several integral power supplies within the Annunciator. The location of integral power supplies within the Annunciator can be noted by the five position terminal block, TB5.

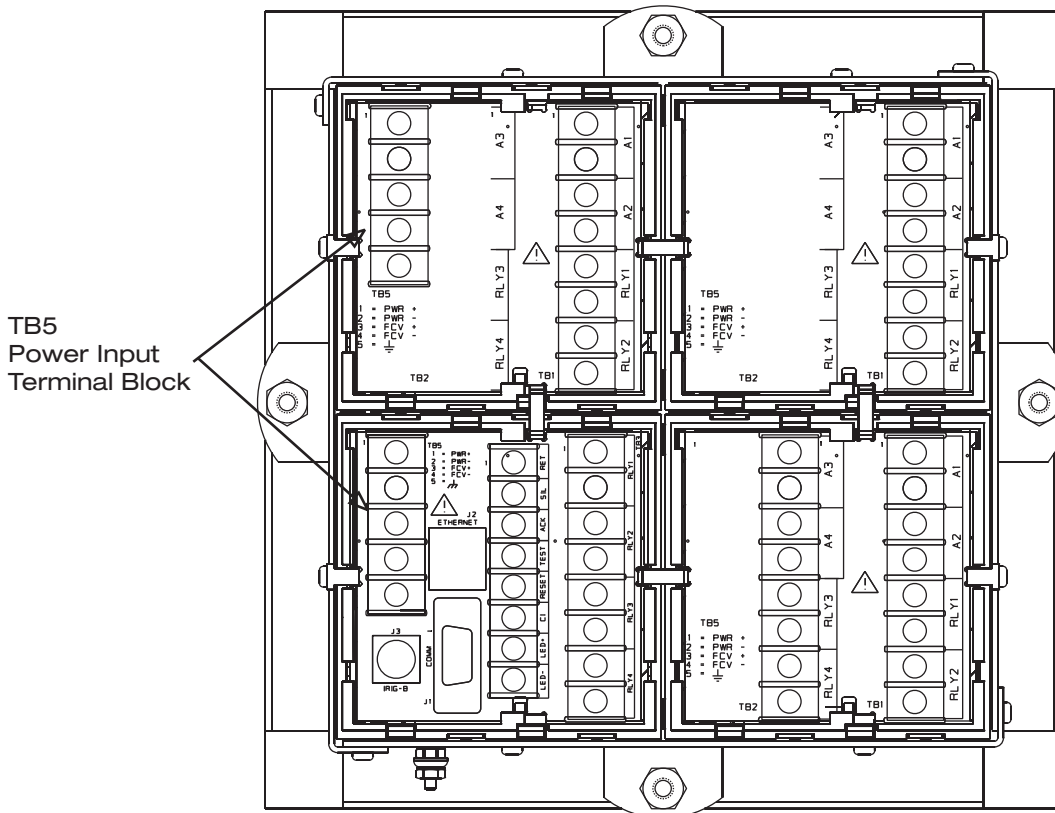

125VDC or 120/230 VAC Integral Power Supply

This universal integral power supply will accept either AC or DC inputs (not simultaneously) and provides a 5VDC output.

Quantity of Inputs per Integral Power Supply

Annunciator Window Size	I/O Cards with Repeat Relays	I/O Cards with no Repeat Relays
Full (1 per Cell)	25	30
Half (2 per Cell)	43	60
Third (3 per Cell)	56	90
Quad (4 per Cell)	60	100

Systems that exceed these quantities shall use an External Power Supply.

125VDC or 120/230VAC Integral Power Supply

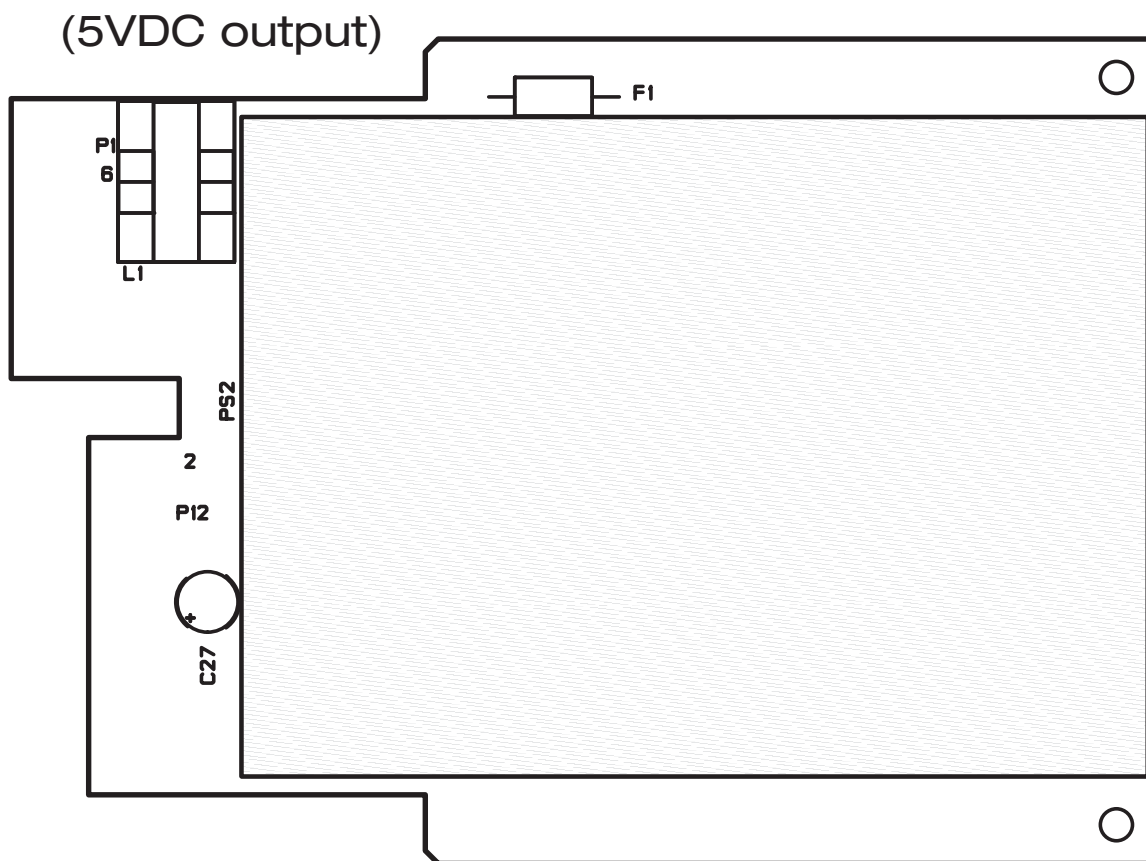

125VDC or 120/230VAC Integral Field Contact Voltage (FCV) Supply

The Integral FCV Supply is installed in slot 5 of the I/O Cell. This FCV supply will allow either AC or DC inputs (not simultaneously) and provides a 24VDC or 125VDC output.

Quantity of Inputs per FCV Supply

Field Contact Voltage	Number of Inputs
24 VDC	250
125 VDC	52

Systems that exceed these quantities shall use an External Power Supply.

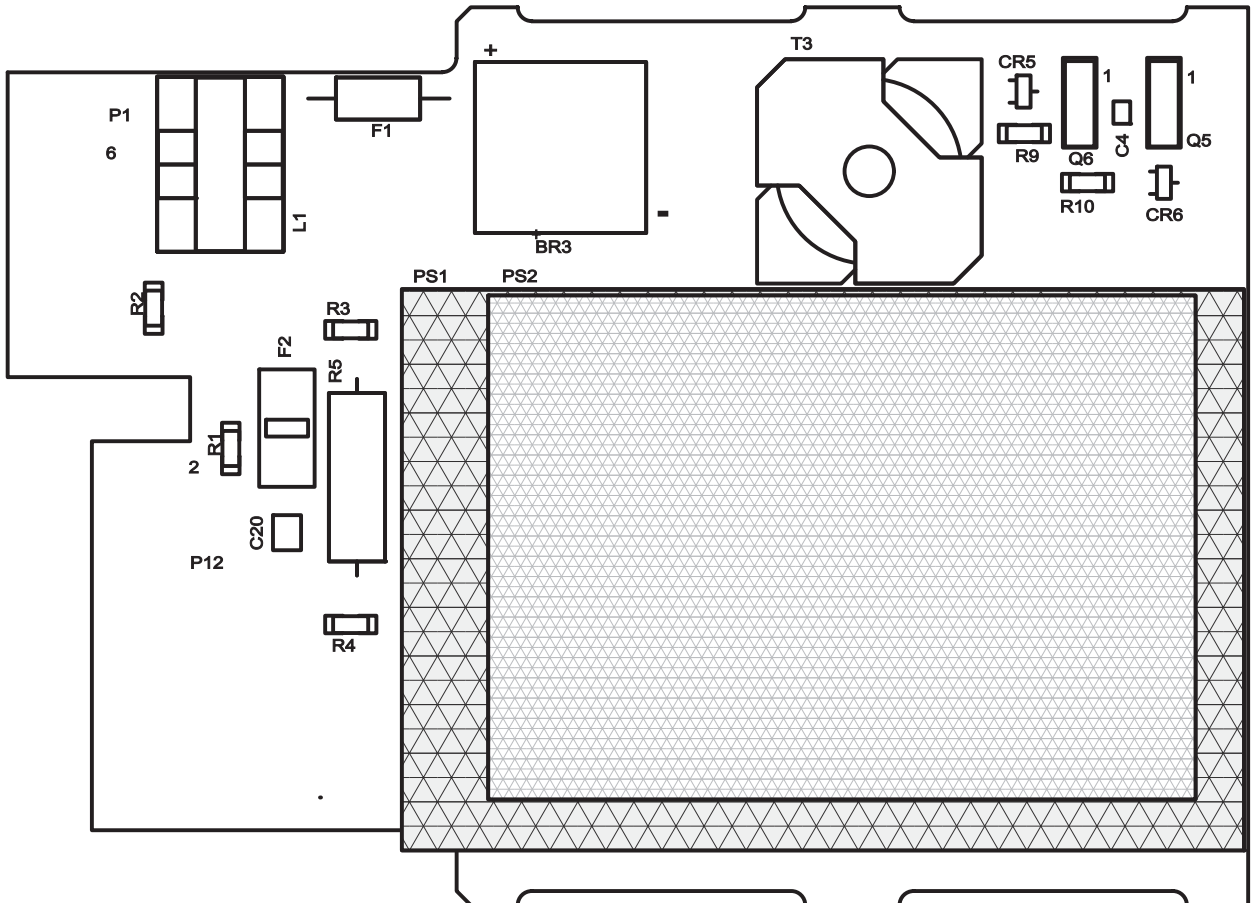

120/230 VAC and 125 VDC Integral Power Supply Wiring

Cell Variations for Power Supply Terminal Blocks (TB5)

I/O Terminal Ass'y

Single I/O Module

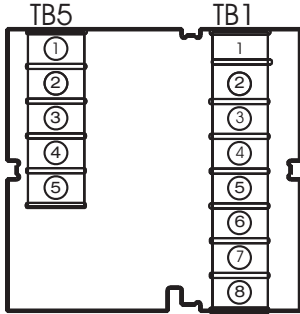

(Rear View)

I/O Terminal Ass'y

Dual I/O Module

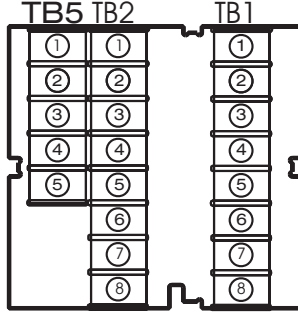

(Rear View)

CSM Terminal Ass'y

Single I/O Module

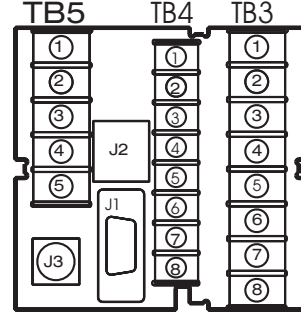

(Rear View)

125VDC Power External 125VDC FCV

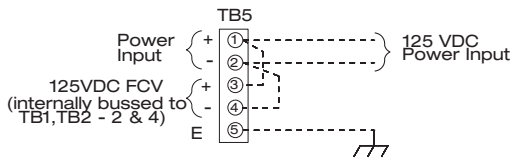

125VDC Power External 24 or 48VDC FCV

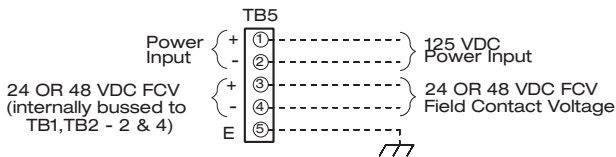

120/240 VAC Power External 24, 48, 125VDC FCV

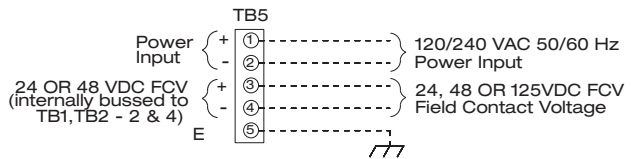

125VDC Power Internal 24V or 48VDC FCV

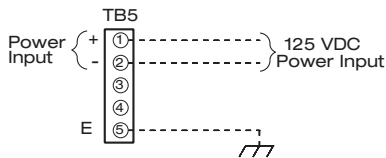

120/240 VAC Power Internal 24, or 125 DC FCV

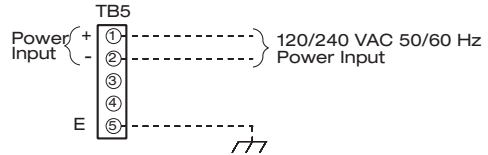

125VDC Integral FCV Supply

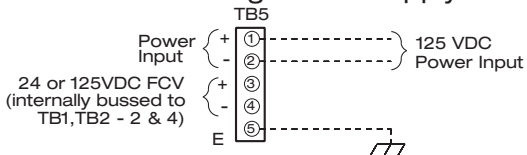

120/240VAC Integral FCV Supply

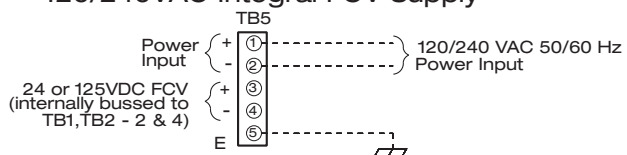

24VDC Integral Power / FCV Supply

This integral power supply is used for 24VDC Power Inputs or whenever external AC/DC power supplies are provided. The 24VDC input is converted to a 5VDC output. An FCV Supply can be added to this integral power supply for systems requiring 125VDC FCV.

Quantity of Inputs per Integral Power Supply

Annunciator Window Size	I/O Cards with Repeat Relays	I/O Cards with no Repeat Relays
Full (1 per Cell)	22	26
Half (2 per Cell)	37	52
Third (3 per Cell)	49	78
Quad (4 per Cell)	52	87

Quantity of Inputs per FCV Supply

Field Contact Voltage	Number of Inputs
125 VDC	52

Systems that exceed these quantities can use multiple integral FCV Supplies

24VDC Integral Power Supply
(5VDC Output)
Shown with 125VDC FCV Supply

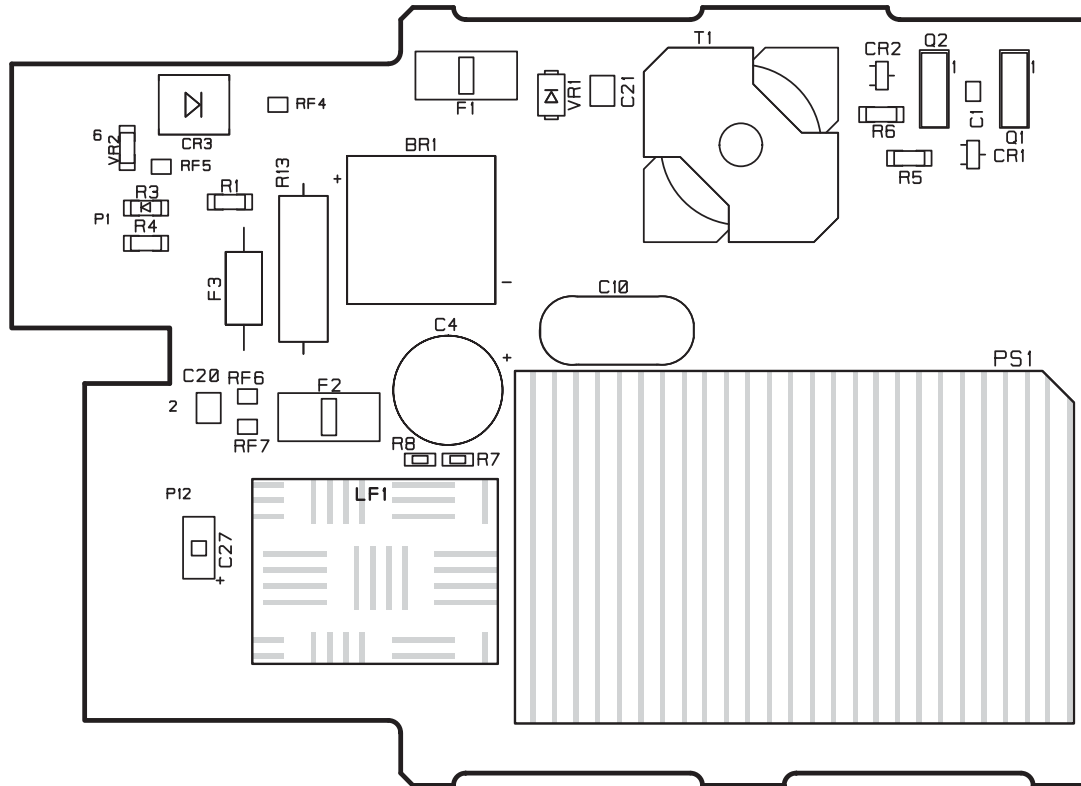

48VDC Integral Power Supply

This integral power supply is used for 48VDC Power Inputs. The 48VDC input is converted to a 5VDC output.

Quantity of Inputs per Integral Power Supply

Annunciator Window Size	I/O Cards with Repeat Relays	I/O Cards with no Repeat Relays
Full (1 per Cell)	22	26
Half (2 per Cell)	37	52
Third (3 per Cell)	49	78
Quad (4 per Cell)	52	87

48VDC Integral Power Supply
(5VDC Output)
Shown for external FCV

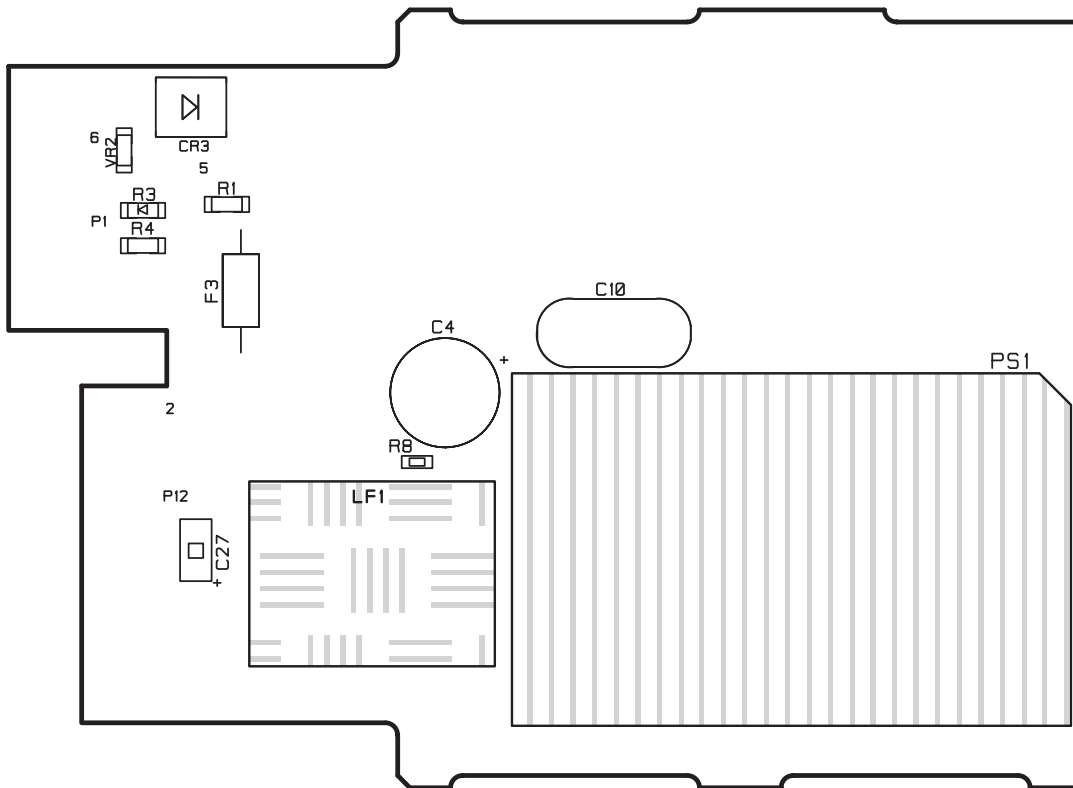

Note: In order to maintain a UL listing or CE Certification, any customer power supply used to provide 24VDC or 48VDC to the Annunciator shall be UL recognized or CE Certified, and provide basic insulation.

24 and 48 VDC Integral Power Supply Wiring

Cell Variations for Power Supply Terminal Blocks (TB5)

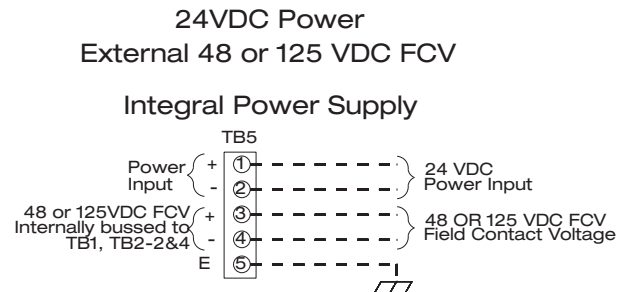
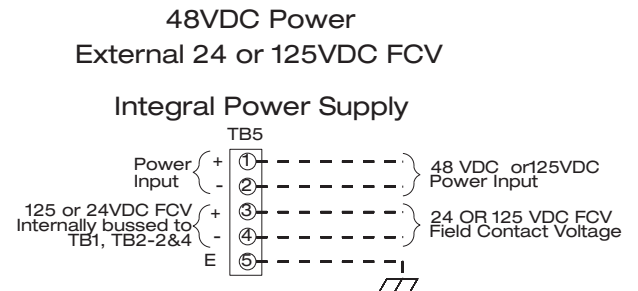
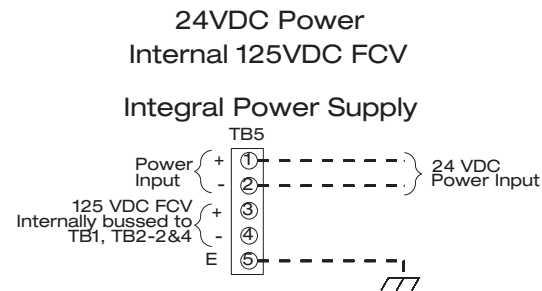
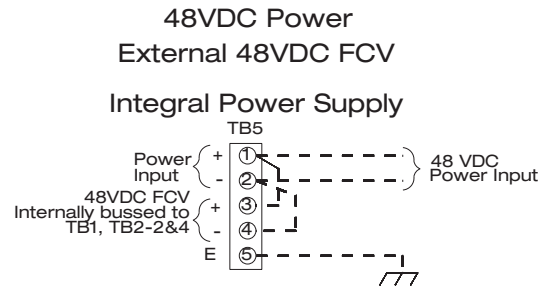
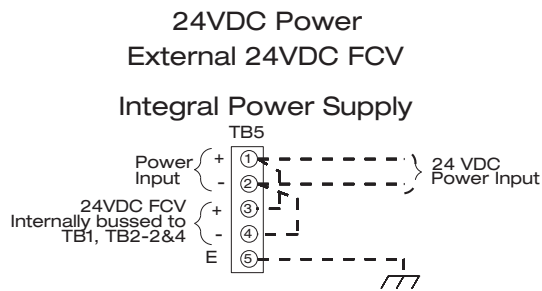
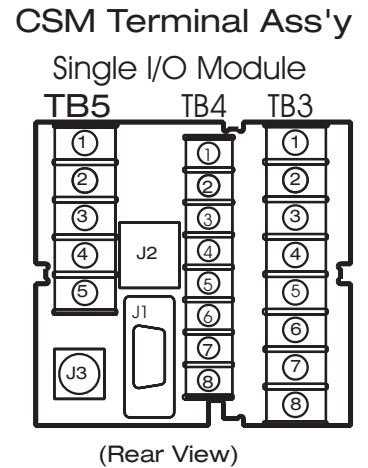
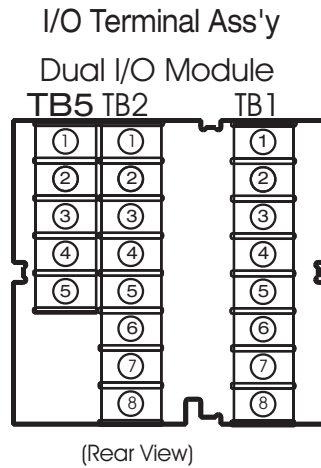
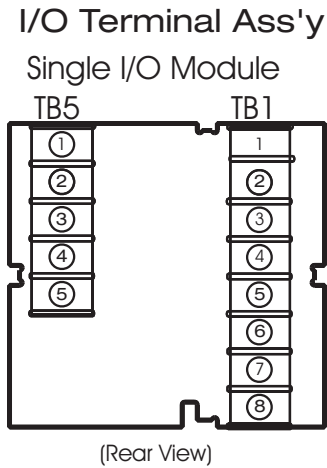

External Power Supply

For larger systems, an external power supply can be used for 120/230 VAC or 125VDC Input Power. In either case, the external power supply has a 24VDC output used to connect to the Integral 24VDC Supply. The quantity of Integral 24VDC Supplies required is shown in the chart below.

Quantity of Inputs for External Power Supplies

Annunciator Window Size	(1) AC or DC External Power Supply		(2) AC or DC External Power Supplies	
	(2) Integral 24VDC Supplies		(3) Integral 24VDC Supplies	
	# of Inputs (with Repeat Relay option)	# of Inputs (without Repeat Relay option)	# of Inputs (with Repeat Relay option)	# of Inputs (without Repeat Relay option)
Full (1 per Cell)	43	52	65	78
Half (2 per Cell)	74	104	111	156
Third (3 per Cell)	98	157	147	235
Quad (4 per Cell)	104	173	156	260

Annunciator Window Size	(2) AC or DC External Power Supplies		(3) AC or DC External Power Supplies	
	(4) Integral 24VDC Supplies		(5) Integral 24VDC Supplies	
	# of Inputs (with Repeat Relay option)	# of Inputs (without Repeat Relay option)	# of Inputs (with Repeat Relay option)	# of Inputs (without Repeat Relay option)
Full (1 per Cell)	87	104	108	130
Half (2 per Cell)	149	208	186	260
Third (3 per Cell)	195	313	244	392
Quad (4 per Cell)	208	347	260	433

For Field Contact Voltage, 24VDC can be derived from the External Power Supply 24VDC Output. For 125VDC, the Integral 24VDC Supply will be used.

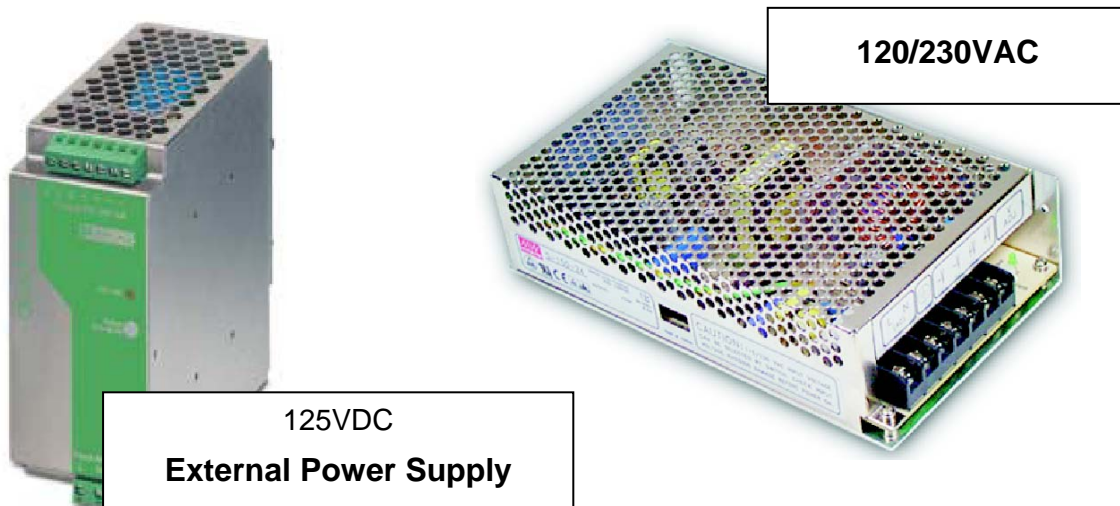

125 VDC External Power Supply Wiring

Internal 24 or 125VDC FCV 24 VDC Integral Power Supplies

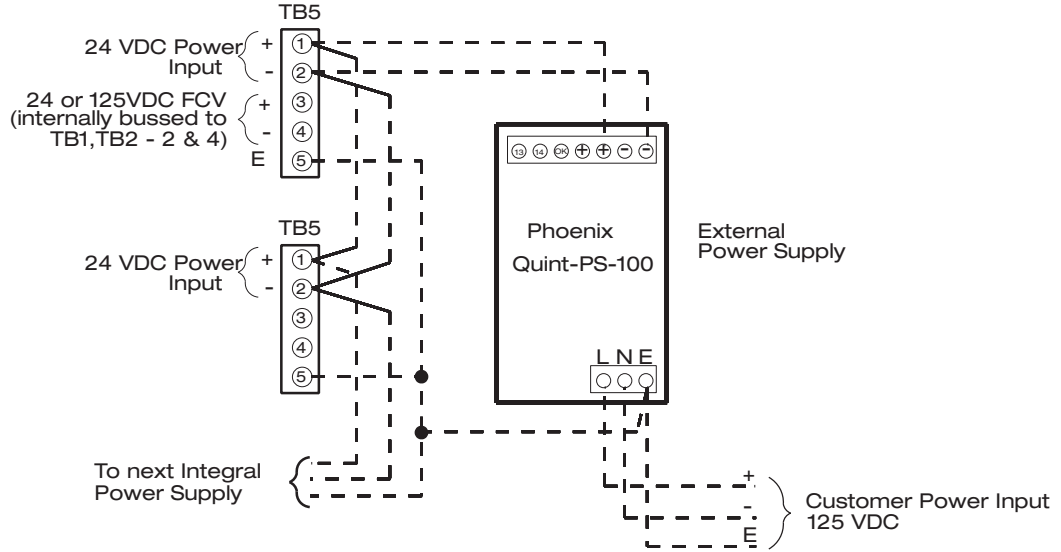

External 24,48,125VDC FCV

24 VDC Integral Power Supplies

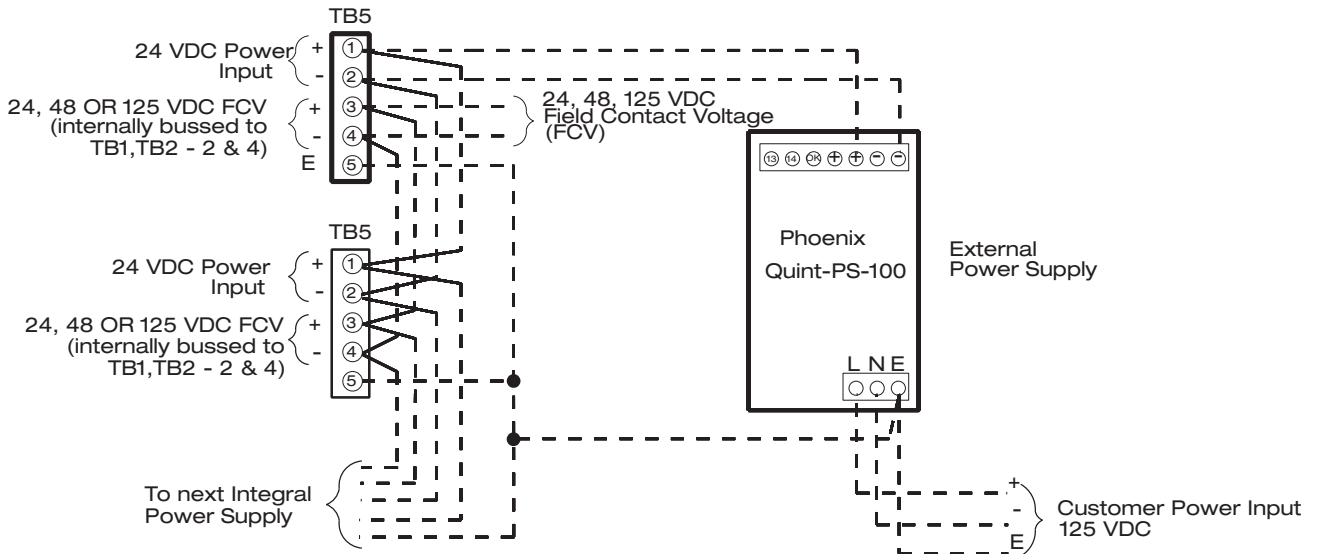

120/230 VAC External Power Supply Wiring

Internal 24 or 125VDC FCV

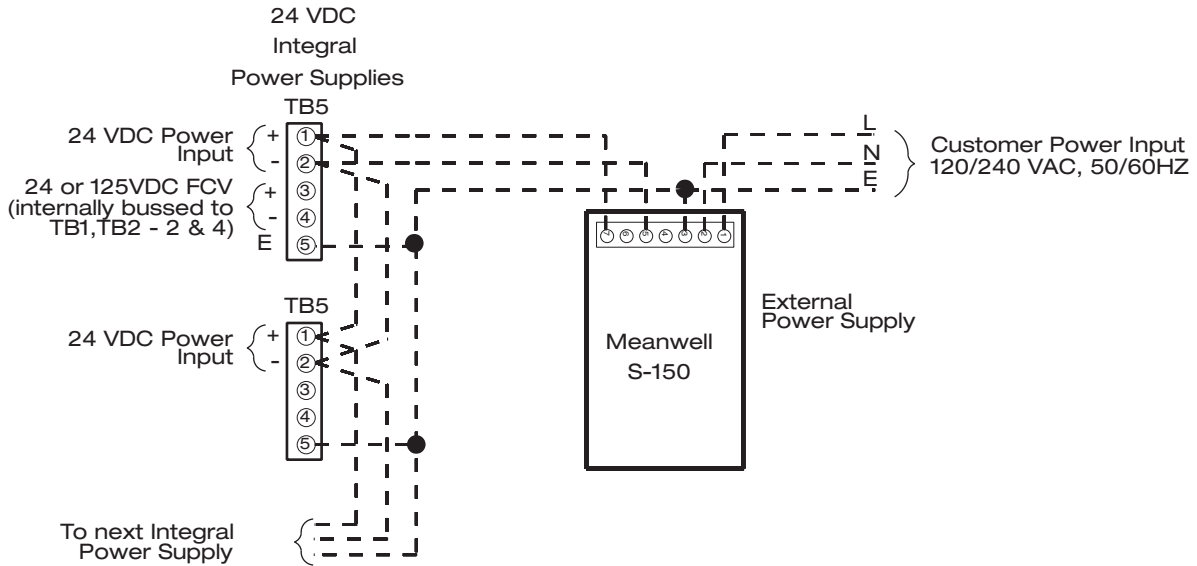

External 24,48,125VDC FCV

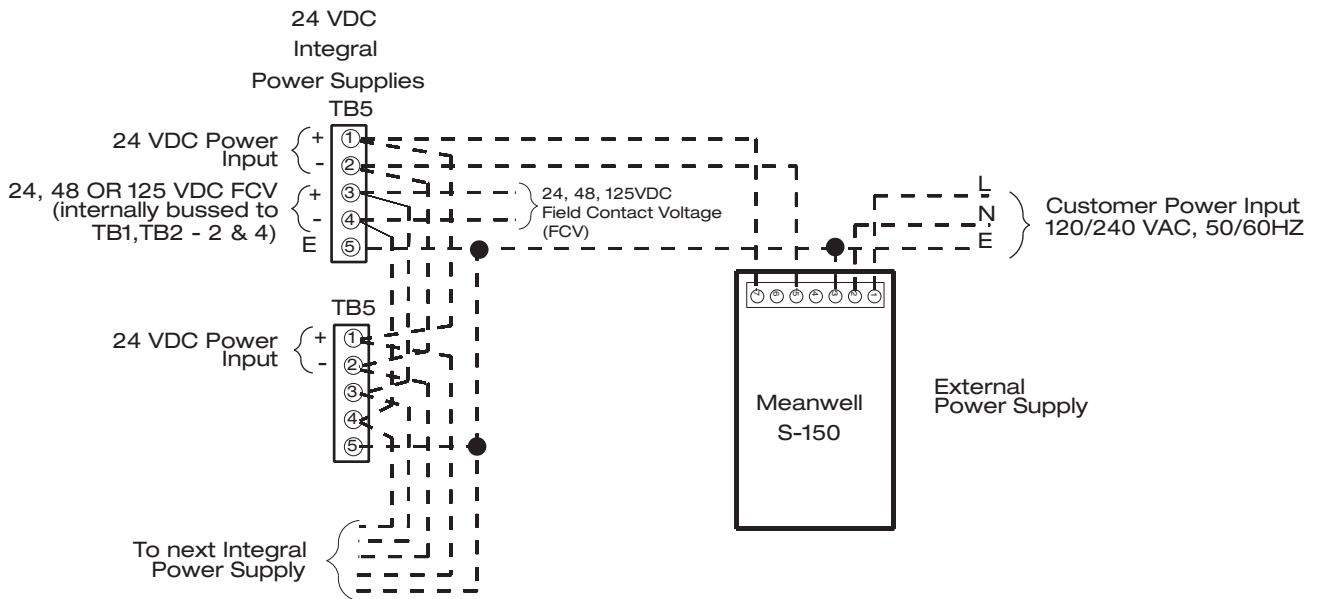

SOFTWARE CONFIGURATION

APPLICATION

The SERIES 90A Annunciator Configurator application is used to create, edit and download annunciator configurations from a PC. The PC Comm Port connects directly to the annunciator via a serial port on the front of the CSM module.

A configuration may be created on the PC without a connection to the annunciator and then downloaded later. The configuration information is held as a file on the PC, which may be edited if a change is required. An exception to this is the physical size of the annunciator, which includes the number of input modules, and the size of each module, which is factory configured.

If a configuration is edited, checks are made to ensure that the correct file is downloaded to the annunciator. If more than one version of the SERIES 90A configuration software is used then more than one version of the configuration file can exist. It is up to the user to ensure that copies of the configuration are kept up to date. If the application detects that the local and remote copies of a configuration are different the user can update either.

The application also includes a function to enable the configurable options in the annunciator, such as Modbus and DNP communications.

SOFTWARE INSTALLATION

The SERIES 90A configuration software should be installed onto a PC with the following minimum configuration: -

300MHz Pentium II CPU

Windows 98/2000/XP

64Mbytes RAM

20Gbytes hard disk

Insert the AMETEK SERIES 90A Configuration CD in the CD-ROM drive. This will automatically start the installation process. If this does not happen choose '*Run*' from the '*Start*' menu then browse to the CD-ROM drive and click on '*Autorun.exe*'.

During the installation, you will be prompted to select the type of Annunciator you wish to configure. Select only the models you wish to use to avoid confusion with extra choices.

SOFTWARE CONFIGURATION INSTRUCTIONS

This is an overview of the configuration steps required for editing or creating an Annunciator configuration. Refer to the next section for additional detail on the menu selections.

Reviewing or editing the Factory Configuration

All Annunciators are factory configured per the model number. Some of these selections, such as Alarm Sequence can be changed with the configuration software. Other features not in the model number, such as N.O./N.C. Inputs, Input Delay, CSM Relay Outputs can also be edited.

1. Remove the front mounted pushbuttons in the CSM Cell (or windows used in the lower right Cell) to gain access to the CSM front mounted Serial Port. Connect the serial (one to one) cable provided with the Annunciator between the SERIES 90A CSM Port and the PC with the Configuration Software installed. (**Note:** The serial port on the rear of the Annunciator is used for the optional communications; Modbus, DNP, etc. It is NOT used for the system configuration.).
2. Start up Configurator Software. If a default configuration appears, press Cancel.
3. Select Connections, then Settings and configure your PC Serial port for the Com Port where your serial cable is plugged into, 9600 Baud, no parity and address 1
4. Select Connections, and then Connect. If successful, the Annunciator lights will flash fast and a pop up screen will appear with your serial number. Press OK.
5. If you see a screen that says 'Configuration Mismatch', select Download Configuration from the Annunciator.
6. If you see a screen that says 'This is not the correct configuration file type for this Annunciator', Select File, and Open up a known configuration file for this type of Annunciator. If a file is not available, follow the instructions below for creating a new configuration.
7. Start the configuration software and select File, New. Select the correct type of Annunciator if prompted. Select Cancel in the configuration menu. Select Connections, and then Connect. You may be prompted to configure certain options not present in your configuration; select NO. Cancel out of any configuration menus. Select Connections, Configuration, Read Configuration. When done, you can Select File, Start Wizard and this will show how the Annunciator is currently configured.
8. Select File, Start Wizard and this will show how the Annunciator is currently configured. You can make changes to any of the selections. For more detail on any of the selection, refer to the next section on the Configuration Wizard.
9. When finished making any changes, select save and enter the file name if

prompted. Select Connections, Configuration, Write Configuration. When it is complete, select Connection, Disconnect. Press the TEST pushbutton to verify that everything is functioning correctly.

Creating a new Configuration

New configurations may be created both on-line (connected to an Annunciator) or off-line.

1. Start the configuration software and select File, New. Select the correct type of Annunciator if prompted.
2. The Annunciator Configuration Wizard will start up allowing you to make all configuration selections.
Note: When creating a new configuration, make sure you select the correct System Size (rows high x columns wide) and Window Size (1, 2, 3, 4 windows per cell), otherwise, it can disrupt all settings.
3. Select all configuration choices desired (reference the next section for a complete description of choices). When done, save the file.
Note: Some options, such as Modbus, DNP, and CSM Relays will not be shown in the 'New' file configuration. Once you connect to the Annunciator, it will indicate which options are available.
4. If off-line during the configuration, you can connect the PC to the Annunciator and download the configuration. (Select Connections, Configuration, Write Configuration.)
5. After you connect to the Annunciator, you may be prompted to configure certain options not present in your configuration. You can configure these options if desired and then save the file when done. Select Connections, Configuration, Write Configuration. When it is complete, select Connection, Disconnect. Press the TEST pushbutton to verify that everything is functioning correctly.

SOFTWARE CONFIGURATION MENUS

Main menu overview

The main application window comprises of five main menus, File, Options, View, Connections and Help. These appear at the top of the screen above the application toolbar, which provides quick access to the main functions of the program.

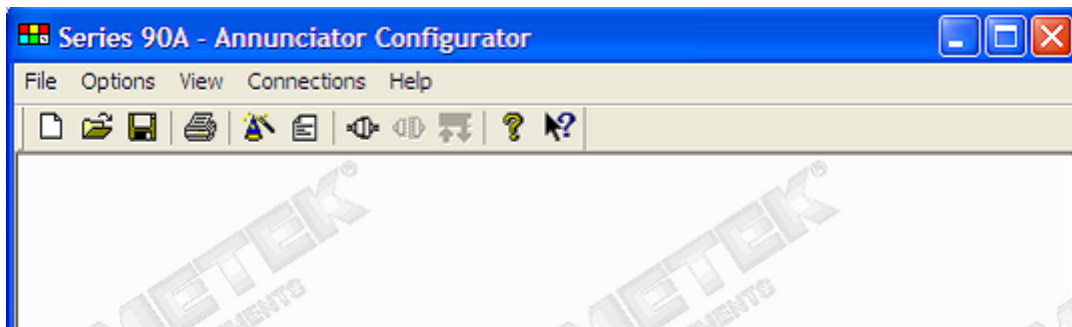

File Menu

The program manages configuration files through the File Menu. From this menu, you can open, save, and delete configuration files. The File Menu also provides you access to a new "default" configuration as a point of reference.

Options Menu

This menu provides functionality to alter the way your program behaves and appears.

View Menu

Here you can select what you see in main window. Status bar, Tool bar etc.

Connections Menu

Connections menu performs the actual communication with the annunciator to download or retrieve configurations.

Help Menu

The Annunciator Configurator is equipped with a Help Menu to provide the user with assistance for each screen and program function.

File

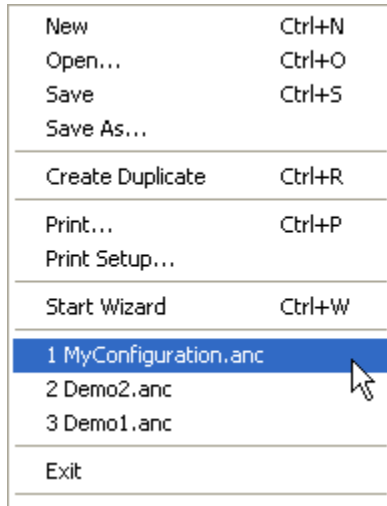

In the File menu you will find the following menu options:

New

Clicking on this will create and open a new configuration. As only one configuration can be open at a time, any previous configuration that is open will be closed. You will be prompted to save any changes before the configuration is closed. New configurations are set to the defaults.

Open

Here you can browse available locations on your system to open existing configuration files. (file extension ".anc").

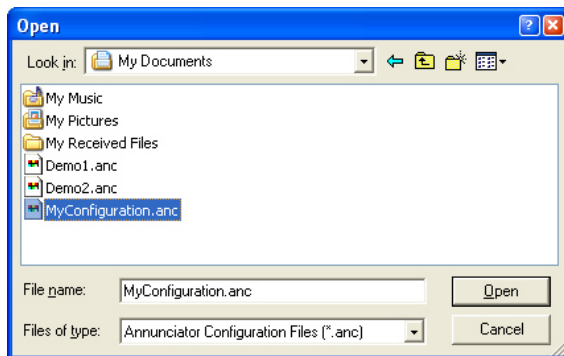

Save

Allows you to save the active configuration file. If the configuration file has already been saved, it will automatically write over the old version.

Save As

Allows you to save the active configuration file. When clicked, it will ask you for a filename before proceeding. If the filename already exists, it will ask you if you want to overwrite the old version.

Create Duplicate

This will create and open a new configuration file; the parameters will be copied from the active (open) configuration and not set to defaults. This allows the same configuration settings to be downloaded to two annunciators.

Print

This allows you to print the configuration in a text form so that you can see all the parameters. The printout is marked with the time and date of printing.

Print Setup

This allows you to change your printer settings.

Start Wizard

This will start the configuration wizard, which will guide you through a set of screens to simply setup your annunciator.

Recent Files

At the bottom of the file menu, you will also find a list of you most recent configuration files. You can simply click on one of these to open it.

Options

Preferences
View Configuration Ctrl+V
Upgrade

Preferences

In the preferences menu you can change the color setup of the whole application, and tell the program how you want the wizard to behave.

View Configuration

This is a textual overview of the complete configuration.

Upgrade

This menu option will allow you to add extra functionality to your annunciator and the configurator.

Preferences

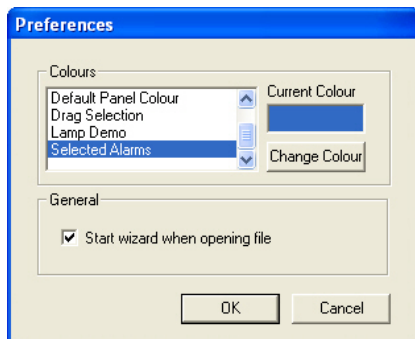

Colors

The colors used to indicate various selections used in the configuration software may be changed. This may be required if they conflict with colors used in the Windows desktop. For most installations the default colors will be acceptable.

To change a color first select its usage from the list then click on 'Change Color' and select the new choice from the palate.

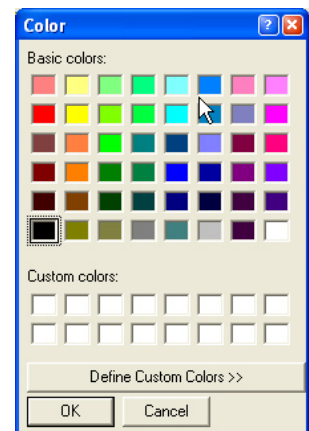

General

If the box beside "Start wizard when opening file" is checked, the wizard will automatically appear every time a new or existing document is opened. As the last open configuration is loaded when the application starts it means that the wizard will also automatically start at this point.

View Configuration (Text)

This allows you to see the complete configuration as text. Once this dialog is shown there are a number of options available.

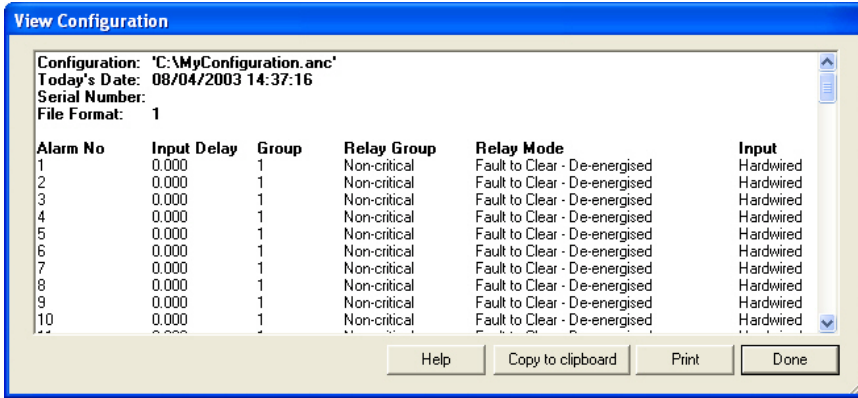

Copy to clipboard

You can use the mouse to select a portion of the configuration and then copy the selection to the clipboard so you can paste it into other documents. If you do not select any text the whole configuration is then copied.

Print

This will print the complete configuration.

Upgrade

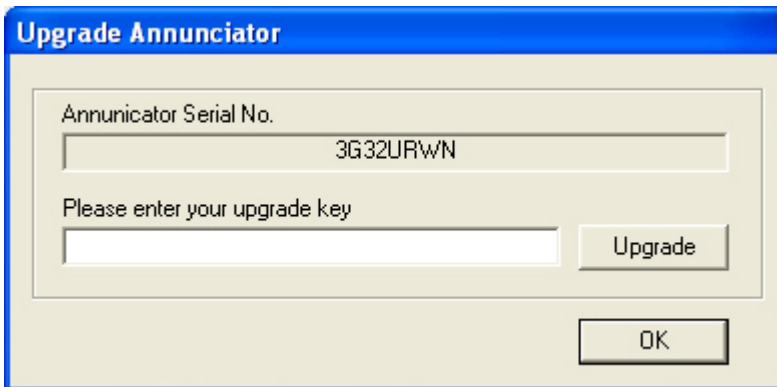

The application also includes a function to enable the configurable options in the annunciator. One such is Modbus communications.

To enable any of these options you must contact AMETEK Power Instruments with your annunciator serial number that you will find in the Upgrade dialog. You will be given a unique key, which you must type into the box (shown above) and then click upgrade.

If you are connected to an annunciator the upgrade will be performed right away. If you are not connected then you must save the configuration and upload it at a later date.

Note:

To successfully obtain the serial number of the annunciator you must have uploaded the configuration at least once. If the configuration has never been uploaded to an annunciator you will get the following message where your serial ID should be.

"This configuration has not been uploaded to an annunciator."

Connections

Connect	Ctrl+C
Disconnect	Ctrl+D
Configuration	
Setting	
Connect Status	Ctrl+T

Connect & Disconnect

From the connections menu you will be able to connect to or disconnect from your annunciator using the *Connect* and *Disconnect* menu options.

Configuration

Once you have successfully connected to your annunciator you will be able to select the *Configuration* menu option. This will allow you to read and write configurations to and from the annunciator.

Settings

Here you change your computer's settings to tell it how to connect to your annunciator.

N.B. The annunciator functions will not operate while the configurator is connected to the SERIES 90A.

Configuration

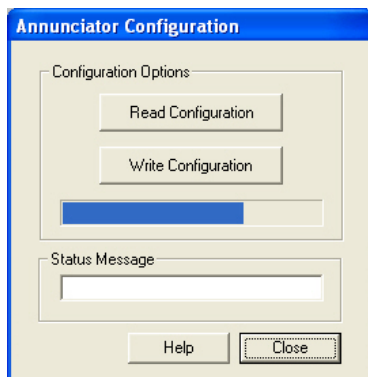

Read Configuration

This copies the configuration from the annunciator into the active configuration. It is recommended that you save any configuration changes before reading a configuration. If you wish to discard your changes you can open another document or close the application opting not to save.

Write Configuration

This will copy the active configuration to the annunciator. It is recommended that you save any configuration changes before writing to the annunciator.

Note:

When a configuration is written to an annunciator the file is, from then on associated with that specific annunciator. As a result of this association, on subsequent sessions there are certain configuration options, which will be disabled. They are listed below.

System Name

Number of rows

Number of columns

Alarms per module

Number of hardwired inputs

Input delay resolution

They can only be changed when creating a New Configuration.

Note: Changing the system size or window style to something different than your actual Annunciator can cause problems.

Communication Settings

From this dialog you can select the Com port wish to use to connect and the baud rate and parity of the connection, and the *address* of the annunciator.

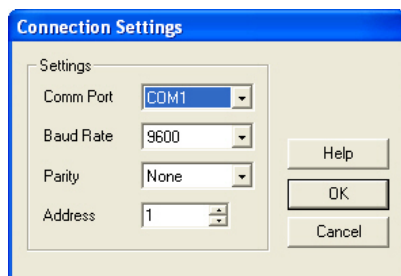

These values are stored independently of the annunciator hence care must taken be as if you have more that one annunciator they may not all have the same settings.

Connect Status

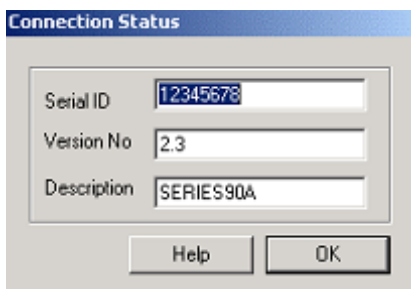

This option can be used when connected to retrieve the serial ID, the Hardware version and the system description. When nothing is connected the menu option is disabled. This can be used as an indicator to a successful connection.

Configuration Mismatch

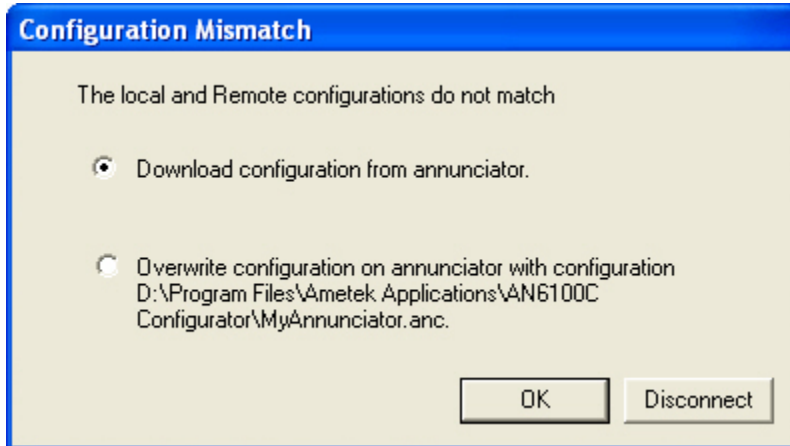

When you connect to an annunciator the program checks to see if the active file was the last configuration to be downloaded to the annunciator, if this is not the case then the message shown above will be displayed.

A Configuration mismatch may occur as a result of the following:

- 1) You have opened the wrong configuration file.
- 2) Someone else has downloaded a different configuration to the annunciator.

If you choose the first option "Download configuration from annunciator" this will copy the configuration from the annunciator in to the active file.

If you choose the second option "Overwrite configuration on annunciator with configuration....." this will copy the configuration in the active file to the annunciator.

In the case of a configuration mismatch it is recommended that you select the first option and then save this configuration to another location as a backup.

Serial ID Mismatch

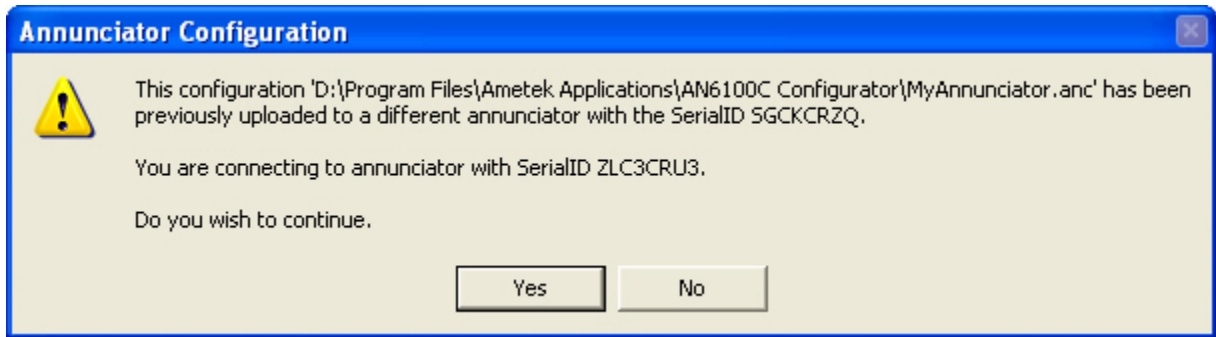

A serial ID mismatch occurs when you try to upload a configuration that has already been uploaded to another annunciator. When you upload a configuration, a note is kept of which annunciator it "belongs to". Every time you connect to an annunciator the stored serial ID is checked to make sure that it matches the annunciator you are connected to.

In the case of a serial ID mismatch if you hit continue you will be able to read the configuration from the annunciator but you will **not** be able to write the active one to the annunciator.

To rectify this situation you should click "No" and then open the correct configuration file, or create a new configuration.

Configuration Wizard

The configuration of an SERIES 90A is defined in a number of sections, which are displayed on separate pages. The pages may be selected by clicking on the labeled tabs at the top of each page. When a system is configured for the first time the 'Next >>' button may be used to move through all the sections. This will ensure that no sections are missed. The '<< Back' button may be used to go to the previous page if required.

A graphical representation of the annunciator is used to simplify the configuration. This mimic diagram may be given the same window colors as the actual unit to make correct input selection easy. Individual or groups of inputs or modules can be selected by clicking on them. (To select a group of inputs, select an input with the mouse and hold & drag across other cells. You can also use the Ctrl key to pick a group of inputs.)

The Configuration Wizard Screens and their functions are detailed below:

System: Used to configure System Size (High x Wide), Window size per cell and other system-wide features. Once configured and downloaded it will be locked to prevent any further changes.

Input Configuration: Used to select individual settings per input, such as input delays, repeat relay operation, critical/non-critical alarms, alarm sequence groups. These settings can be edited or changed at any time.

Lamp Configuration: Used to configure flash rates for slow, fast and intermittent speeds as determined by the operating sequence.

Sequence: Selection of the operating sequence for each alarm group.

CSM: Set-up of auxiliary relays and other system-wide functions.

Switch Input: Set up for optional external switch inputs and Test Pushbutton operation.

Modbus: Modbus set-up configuration. (Only shown when option is enabled.)

DNP: DNP set-up configuration. (Only shown when option is enabled.)

System

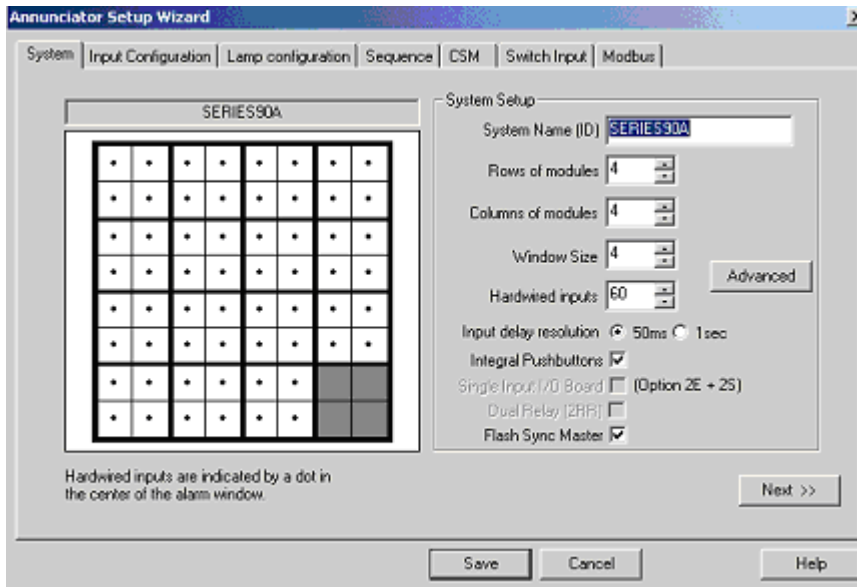

The hardware configuration is defined in this page. The values **must** match the actual size of the SERIES 90A. A mimic diagram of the annunciator is shown on the left hand side. The blank section on the bottom right of the annunciator is the Common Service Module (CSM).

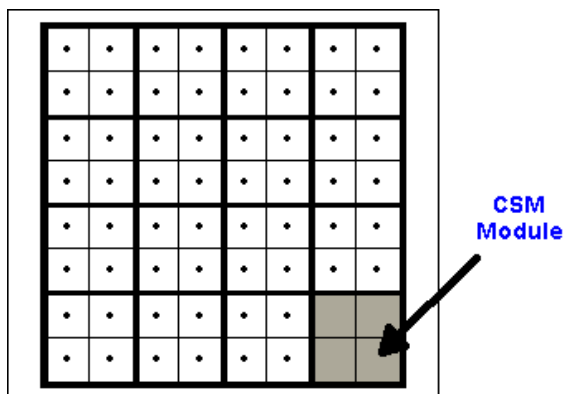

Note: After the configuration is uploaded to the annunciator for the first time the system parameters cannot be edited. The controls will be disabled. Care should be taken that the System values are correct. To make a change, you must create a new configuration.

System Name (ID)

This name is used to uniquely identify the annunciator. Up to 16 characters may be used.

Rows and Columns of Modules

Use the up or down arrows to the right of each value to set the actual number of modules. The AN3100D annunciators are limited to 13 rows or 13 columns and a maximum of 200 alarms or 50 Cells. (Example: a 13 x 4 system is not allowed, but a 5 x 10 is.)

Alarm points per module

There may be 1, 2 or 4 points per module as determined by your window size. Quad size windows use 4 points per cell, Triple Size windows use 3 per cell, Dual or Half Size windows use 2 per cell and Single or Full Size windows use 1 point per cell. By default all modules have the same number of points. If different numbers of points per module are required (Option IMW) click on the Advanced button.

Hardwired inputs

The default is that all inputs are hardwired, which refers to the field contacts wired to the back of the annunciator. On the mimic diagram the hardwired inputs are shown with a dot at the center. Non-hardwired inputs refers to inputs that are received via the serial communications. Non hard-wired inputs do not respond to the I/O cards or field contact inputs.

Note: Serial Communications may be used for both Hardwired and Non-Hardwired systems.

Input delay resolution

This determines the system-wide increment value for the input delay (or response) for each alarm. It is used in conjunction with the individual input delay setting in the Input Configuration Screen. The setting is based on whether your maximum input delay will be 12.5 seconds or 250 seconds. You have 255 increments of the value selected. For the 50ms setting, you can have a selectable software delay in 50 msec increments up to 12.5seconds. For the 1sec setting, you have a selectable software delay in 1 second increments up to 250 seconds. Each input can have its own delay assigned as shown in the Input Configuration page, however, this system setting (50msec or 1 sec) is applied across the whole system.

Integral Push Buttons (Option INTB, NPB)

These are the pushbuttons located in the lower right cell of the Annunciator System. They include Annunciator Functions: Test, Acknowledge, Silence and Reset. They are provided when specified in the model number, using model code INTB. When model code NPB is specified, the integral pushbuttons are not installed and the software box should be unchecked, to allow up to two active alarm windows in this position. For either selection (INTB or NPB), external pushbuttons can be connected to the Annunciator terminal blocks with the same functionality.

Single Input I/O board (Option 2S)

This is selected whenever window size option 2S (two point windows with single input per I/O board) is selected. The standard I/O board has two inputs available, but in certain configurations, as listed above, it is necessary to only activate a single input on this module.

Dual Relay (Option 2RR)

This will provide two repeat relay outputs (each selectable for Form A or Form B operation) for every input. This is only available whenever window size option 1 (single point windows) or 2S (two point windows with single input per I/O board) are selected.

Flash Synch Master (Option FS)

A software selection box is provided for flash synchronization between several different SERIES 90A Annunciators. In systems that require flash synchronization, one Annunciator is configured as the Master (box checked) and all others are configured as the Slave (unchecked). Wiring between the Annunciators is required to share the flash signals. (Reference the Common Service Cell Wiring diagrams.)

In systems that don't require flash synchronization, the Flash Sync Master box must be checked. When setting up a system for flash synchronization, the flash lamp rates should be configured as follows: (reference the Lamp Configuration Screen)

Master and Slave Lamp Flash Rates should be identical except, on the Slave units, set the Slow Flash 'On' time approximately 0.1 sec lower than the Master. This ensures the slave unit is ready and waiting for the sync edge from the master.

Set the Slow and Fast rates in even multiples. (Example: Slow Flash = 1.0 sec, Fast Flash = 0.5 sec). Use of intermittent flash is not recommended.

Use alarm sequences that are either identical between master/slave units or ones that share the same flash rates (slow, fast, etc.)

Note: If a Slave unit does not receive the flash synchronization signal from the Master unit, the slow flash will become steady on.

Input Configuration

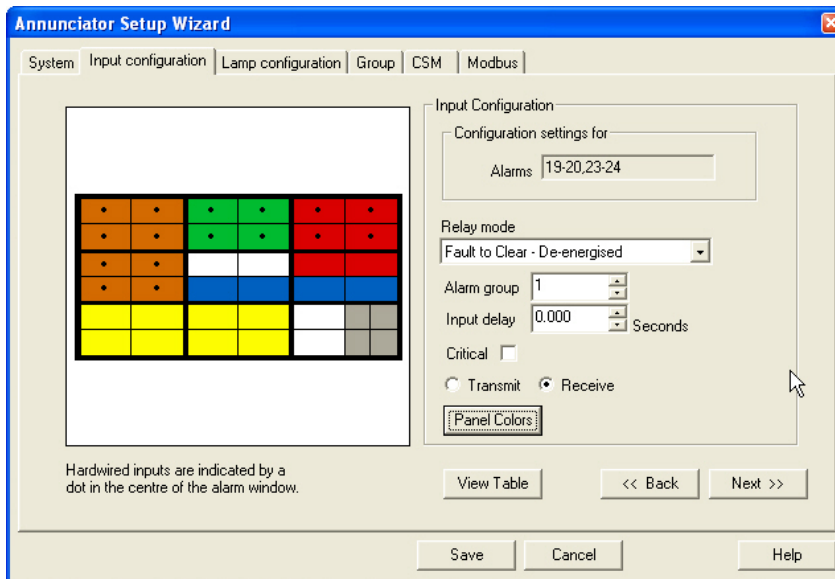

The configuration of each alarm input is defined in this page. To simplify this procedure a number of similar inputs may be selected at the same time and common parameters set.

An individual input is selected by clicking on it. The input will change color when selected. The input number will be shown in the 'Alarms' list. To select a number of inputs hold down the 'Ctrl' key while clicking on the inputs. To de-select an input press the 'Ctrl' key and click on the input again. To select a rectangular block of inputs click on the top left hand one then drag down to the bottom right.

When one or a number of inputs has been selected the parameters for those inputs may be set.

Alarm Numbering

The inputs are numbered left to right and top to bottom. The inputs within a module are numbered in sequence followed by the next module. So, for example, the top row of inputs of modules with four inputs each are:-

1, 2, 5, 6, 9, 10,

Alarm numbering...

1	2	5	6		
3	4	7	8		

Relay Mode (optional)

If the repeat relay option has been included with your system, you may select the Relay Mode for each input as follows:-

Follows Input Contact – Normally Energized

The repeat relay will follow the status of the field contact, regardless of the pushbuttons pressed. In this mode, the relay coil is energized in the normal (non-alarm) state.

Follows Input Contact – Normally De-Energized

The repeat relay will follow the status of the field contact, regardless of the pushbuttons pressed. In this mode, the relay coil is de-energized in the normal (non-alarm) state.

Latched Alarm till ACK – Normally Energized

The repeat relay will change state during an alarm and latch on until the acknowledge pushbutton is pressed, which returns the relay to the normal state. In this mode, the relay coil is energized in the normal (non-alarm) state.

Latched Alarm till ACK – Normally De-Energized

The repeat relay will change state during an alarm and latch on until the acknowledge pushbutton is pressed, which returns the relay to the normal state. In this mode, the relay coil is de-energized in the normal (non-alarm) state.

Latched Alarm till Reset – Normally Energized

The repeat relay will change state during an alarm and latch on until the reset pushbutton is pressed, which returns the relay to the normal state. In this mode, the relay coil is energized in the normal (non-alarm) state.

Latched Alarm till Reset – Normally De-Energized

The repeat relay will change state during an alarm and latch on until the reset pushbutton is pressed, which returns the relay to the normal state. In this mode, the relay coil is de-energized in the normal (non-alarm) state.

Follows Lamp Display – Normally De-Energized

The repeat relay will follow the state of the lamp display for that input. When the display is flashing on and off, it will toggle open and closed at the slow flash rate. When the lamp display is on steady, the repeat relay contact will be closed. It will open when the lamp turns off.

Note: In addition to these configurations, the repeat relay contact may be selected as a Form A or (Normally Open) or Form B (Normally Closed) using the I/O jumpers described in the previous section.

Alarm Group

Each input belongs to one of 4 groups. The groups define the alarm sequences that are set in the 'Group' page. This allows up to 4 first out groups per system or four different sequences.

Input delay

This is also referred to as the input response time, which is the amount of time an input must be in the alarm state before it is recognized as a valid alarm. Each input may be set from 1 second to 250 seconds in 1 second increments or from 50 msec to 12.5 seconds in 50 milliseconds increments. The system wide input delay resolution (50ms or 1sec) is set on the System page.

Systems with FR Option enabled (1 msec response) will have an additional software selection shown for 1 msec input.

Note: The Input Delay is the total delay including hardware and software filtering. For AC Inputs, there will be an additional 40 msec hardware filtering delay added to these numbers.

Critical alarm

Alarms may be selected as critical or non-critical for segregating inputs into a common alarm relay output on the CSM. The CSM has separate relays for critical or non-critical horns, reflash and fault outputs. Any input in the system selected for critical or non-critical will activate the respective CSM relay output. By default, all alarms are set as non-critical.

Modbus Transmit or Receive (Optional)

If the Modbus option is included with your system, every input is defined for Transmit or Receive by clicking on the button. Transmit implies that the alarm status from hardwired contacts are sent serially to some other device. Receive implies that some other serial device is providing the status of the alarm and the Annunciator will respond as if it were a field contact input. You may choose

combinations of transmit and receive, but a single input cannot do both. You may also set up an input as receive while providing a hard-wired contact input to the same point. In this case, the Annunciator will respond to alarms from either the contact or serial input in a logic OR arrangement. If the option is not available this button is not displayed. It may also not be displayed if creating a new configuration. You must connect to your Annunciator to enable the serial Modbus configuration.

Note: Systems with Serial Inputs only (not Hardwired) cannot be set to 'transmit'.

Panel Colors

The color of each input in the mimic diagram may be changed to match the actual annunciator. To do this, select all the inputs with the same color as described above then click on 'Panel Colors'. From the color selector dialog choose any color. The custom colors represent the available window colors. Repeat this for each color.

Table View

Click on the Table View button to display the current input configuration in a table format. This is designed to be a summary of all the input configuration, but by clicking on the individual items you can change the selection from the table.

The column widths may be adjusted by clicking and dragging on the vertical separators between the column titles.

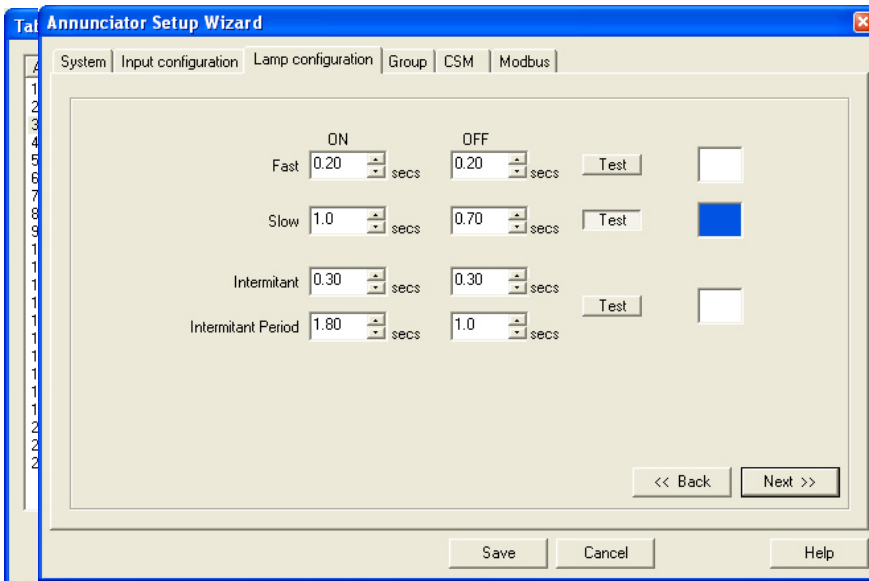

Lamp Configuration

The lamp flash rates are defined in this page. The operational sequence chosen determines whether a slow, fast or intermittent flash rate is used. For example; Sequence TFS uses all three rates while Sequence AF uses only the slow flash rate.

Click on the up or down arrows beside each number to increment or decrement it. Click and hold on the arrows to scroll up or down. Click on the 'Test' button to check the appearance of each flash rate.

Fast & Slow flash rates

The ON and OFF times are set up with a resolution of 0.1s. The maximum times are 4s.

Intermittent rate

The Intermittent period values will be automatically adjusted to ensure they are integer multiples of the sum of the Intermittent ON and OFF times. The maximum Intermittent Period ON and OFF values are 25s.

Note:

The **intermittent on period** may be adjusted automatically by the wizard so that it is set to at least one full intermittent on - off cycle.

Sequence

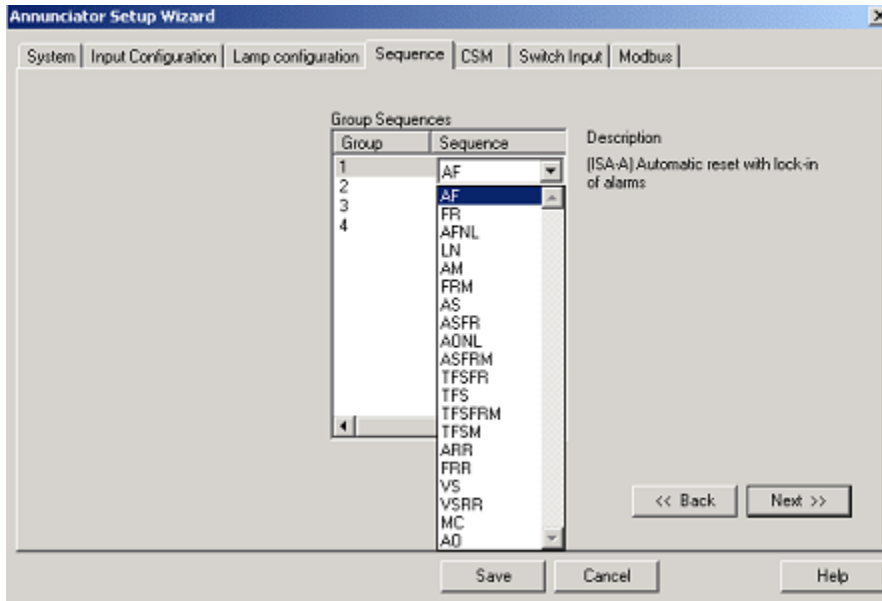

The alarm sequence for each input group is defined in this page. The Input Configuration page was used to indicate which of the four available groups was assigned to each input. This page identifies the sequence chosen for each group.

Note: The four available groups can be set up for the same First-Out Sequence, but each group is treated separately as its own first out group.

To change the alarm sequence, click on the entry then choose the sequence from the list.

LN	Automatic reset, non-locking, no flash, no audible, no PB
AO	Automatic reset with lock-in of alarms, no flash
AONL	Automatic reset, non locking, no flash
AF	Automatic reset with lock-in of alarms
AFNL	Automatic reset, non locking
FR	Automatic reset with lock-in of alarms, flash reset
AM	Manual Reset with lock-in of alarms
FRM	Manual Reset with lock-in of alarms, flash reset
AS	First out fast flash, subsequent alarm steady, auto reset
ASFR	First out fast flash, subsequent alarm steady, auto reset, w/ silence
ASFRM	First out fast flash, subsequent alarm steady, first out reset, w/ silence
TFS	First out, triple flash, first out reset
TFSFRM	First out, triple flash, first out reset, flash reset, reset
TFSM	First out, triple flash, first out reset, reset
ARR	Ringback, dual flash, lock-in of alarms until acknowledged
FRR	Ringback, dual flash, lock-in of alarms until acknowledged, flash reset
VS	First out, dual color, single flash, with first out reset
VSRR	First out with ringback, dual color, dual flash, with first out reset, reset
MC	Motor Control

CSM (Common Service Module)

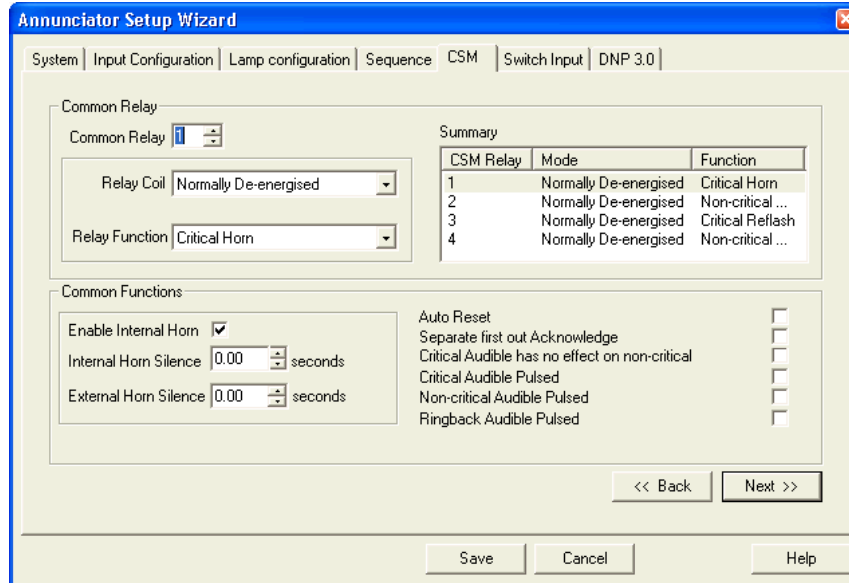

The functions of the CSM are defined in this page.

Common Relay

There are 2 relays in the CSM and an additional 2 can be provided with option **RLY**. Each relay mode may be defined as either Energized or De-Energized, with respect to the power on, normal state. For example, a Energized Relay has a coil that is energized when power is applied and there is no alarm. When the output is activated, the coil will de-energize, transferring the contact output. The Standard relay functions may be selected from:-

Critical horn Auxiliary horn output driven by any alarm selected as critical. The horn relay output will return to its normal state upon activation of the silence or acknowledge pushbutton.

Non-critical horn Auxiliary horn output driven by any alarm selected as non-critical. The horn relay output will return to its normal state upon activation of the silence or acknowledge pushbutton. Note: If a critical horn is used in addition to the non-critical horn, the critical horn has priority. For example; if the non-critical alarm is on and the Annunciator receives a critical alarm, the non-critical horn will turn off and the critical horn will turn on. When the critical horn is silenced, any new non-critical alarms will activate the non-critical horn. This operation can be changed in the common functions below.

Ringback (clear horn) An output driven by the return to normal of an alarm input. Operated by sequences ARR, FRR, and VSRR only.

The following functions are included with the **RLY** Relay Option:

Critical Reflash Grouped output driven by any alarm selected as critical. Upon a critical alarm, the relay output changes state. Every new critical alarm will pulse the relay output for approximately ½ second. The relay output will return to

its normal state when all critical alarms have returned to normal.

Non-Critical Reflash Grouped output driven by any alarm selected as non-critical. Upon a non-critical alarm, the relay output changes state. Every new non-critical alarm will pulse the relay output for approximately ½ second. The relay output will return to its normal state when all critical alarms have returned to normal.

Critical Fault This relay output will change state when any critical input is in the alarm state. The relay output will only return to its normal state when all critical alarms have returned to normal. The relay output is not affected by the silence or acknowledge pushbutton.

Non-Critical Fault This relay output will change state when any non-critical input is in the alarm state. The relay output will only return to its normal state when all non-critical alarms have returned to normal. The relay output is not affected by the silence or acknowledge pushbutton.

Power Fail This relay output will change state when the Power is lost. The relay coil is energized upon start-up and the contacts will transfer upon a loss of power.

Ground Fault This relay output will change state when a ground fault condition is detected. (Note: Must have Ground Fault Detector Option GF) The ground fault can be either a positive ground (+FCV wire to ground) or a negative ground (FCV return wire to ground).

Watchdog System healthy output. It will activate when the system is not processing alarms, like during the configuration process or when there is a system failure. The Watchdog will detect when there is a remote communication failure, if Modbus or DNP are used. The communication failure would activate after a period of inactivity, including a disconnected or broken cable.

The Configuration Screen will show a summary of the Common Relay functions to the right. To select a relay to edit use the up or down arrows beside the relay number or click on the entry in the summary.

Note: In addition to these configurations, the repeat relay contact may be selected as a Form A or (Normally Open) or Form B (Normally Closed) using the I/O jumpers described in the previous section.

Common Functions

A number of system-wide functions are available through the Common Service Module. To select a function click on the white box to the right of the name so as a tick mark appears. To turn the function off click on the box again so as the tick is removed. The available functions are:-

Enable Internal Horn (Option HN)

When selected, this will activate the internal audible device upon any non-critical or critical horn condition.

Internal Horn Silence (option AS)

The internal horn (option HN) may be automatically silenced after a fixed time. To do this use the up and down arrows to the right of the value box to set the required time. The maximum value is 240s and the resolution is 1.0s.

Note: A setting of 0 indicates that the auto-silence is not activated.

External Horn Silence (Option AS)

This will silence any external horn if selected for CSM Relay #1-4 in the time increment selected. This will automatically silence the Critical, Non-Critical or Ringback Horn when this option is included with the system. The maximum value is 240s and the resolution is 1.0s.

Note: A setting of 0 indicates that the auto-silence is not activated.

Auto Reset

This will activate the Reset function continuously, eliminating the need to manually press this. (Note: this only applies to alarm sequences that require the reset function.)

Critical Audible has no affect on non-critical

This will make the operation of the non-critical horn independent of the critical horn. See the previous section on the operation of the non-critical audible.

Critical Audible Pulsed

This will pulse the critical audible output upon an alarm.

Non-critical Audible Pulsed

This will pulse the non-critical audible output upon an alarm.

Ringback Audible Pulsed

This will pulse the ringback audible output upon an alarm.

Switch Inputs

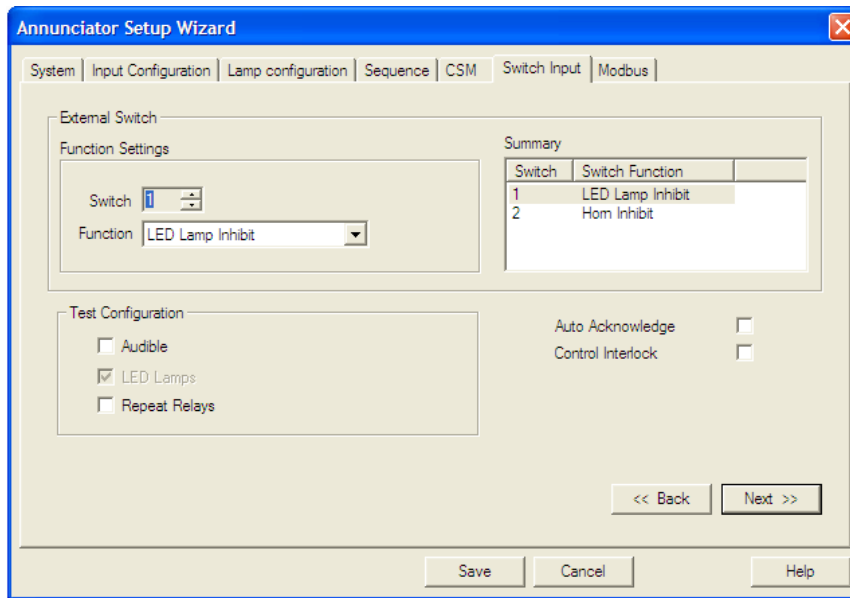

This screen is used to set up the optional External Switch Inputs (Option SW). The External Switch Inputs provide several inhibit functions that are commonly used when the system is left in a 'in-manned state' and there is no need to flash alarms or sound horns. There are other configurations available on this page to configure the Test Pushbutton Operation.

External Switch Function Settings

LED Lamp Inhibit

If selected, whenever the switch is closed, all LED Lamps in the system will be disabled. If the operational sequence chosen latches the alarm (AO AM, etc.), any alarms that occurred while the inhibit switch was enabled as well as any current alarms will be displayed as soon as the switch returns to the 'off' position.

Horn Inhibit

If selected, whenever the switch is closed, all Horns in the system will be disabled. (This includes the internal horn and external horns connected to the CSM Relay outputs.) If the operational sequence chosen latches the alarm (A, M, etc.), any alarms that occurred while the inhibit switch was enabled as well as any current alarms will be sounded as soon as the switch returns to the 'off' position.

Repeat Relay Inhibit

If selected, whenever the switch is closed, all Repeat Relays in the system will be disabled. If the operational sequence chosen latches the alarm (AO, AM, etc.), any alarms that occurred while the inhibit switch was enabled as well as any current alarms will operate as soon as the switch returns to the 'off' position.

Inhibit all CSM Relay Outputs

If selected, whenever the switch is closed, all CSM Repeat Relay Outputs (Horns, Reflash and Fault) will be disabled. If the operational sequence chosen latches the alarm (AO, AM, etc.), any alarms that occurred while the inhibit switch was enabled as well as any current alarms will operate as soon as the switch returns to the 'off' position.

Test Configuration

The following functions can be activated when the Test Pushbutton is used. It applies to the Integral Test Pushbutton on the CSM Module (Option INTB) and to an external Test Pushbutton wired into the Annunciator.

1. Audible If selected, the audible outputs (critical, non-critical and ringback horn) will be activated during the Test Function.
2. LED Lamps: The LED Lamps will always be activated during the Test Pushbutton. There is no selection to de-activate this.
3. Repeat Relays: If selected, the Repeat Relay outputs will be activated during the Test Function.

Other System Configurations

Auto Acknowledge This will activate the acknowledge function continuously, eliminating the need to manually press this. (Note: by selecting this, you will never get any horn outputs and flashing lamps, depending on the sequence selected.)

Control Interlock This requires that the Silence, Acknowledge and Reset pushbuttons are pressed in this exact order. Anything else will be ignored. For example; if the Acknowledge pushbutton is pressed before the Silence, it will not have any effect. (Note: If the Reset function is not required for the alarm sequence selected, it will be ignored.)

Modbus

Note: These options will only be available if the Modbus functionality has been purchased from AMETEK.

Default values of the Modbus settings are given in Appendix B

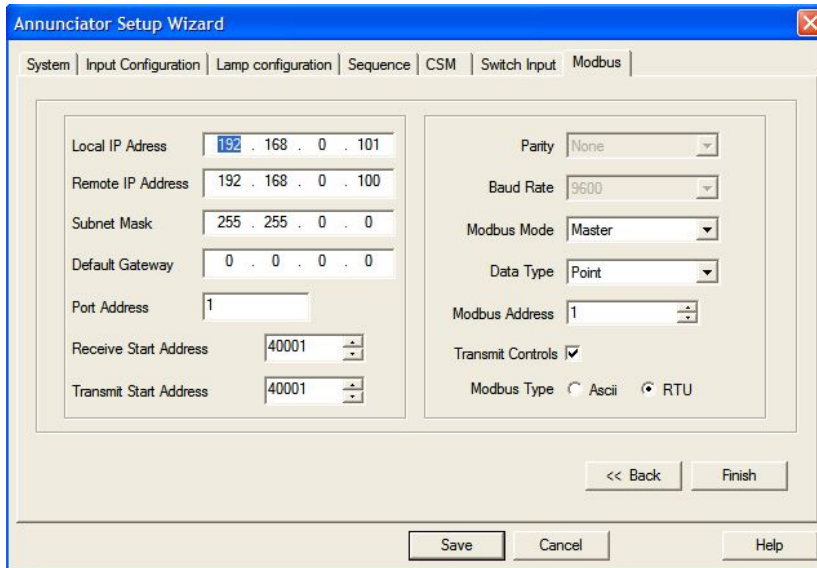

The screenshot shows the 'Modbus' tab of the 'Annunciator Setup Wizard'. The window has a blue title bar and a tabbed interface with tabs for 'System', 'Input Configuration', 'Lamp configuration', 'Sequence', 'CSM', 'Switch Input', and 'Modbus'. The 'Modbus' tab is active. The configuration area is divided into two columns. The left column contains: 'Local IP Address' (192 . 168 . 0 . 101), 'Remote IP Address' (192 . 168 . 0 . 100), 'Subnet Mask' (255 . 255 . 0 . 0), 'Default Gateway' (0 . 0 . 0 . 0), 'Port Address' (1), 'Receive Start Address' (40001), and 'Transmit Start Address' (40001). The right column contains: 'Parity' (None), 'Baud Rate' (9600), 'Modbus Mode' (Master), 'Data Type' (Point), 'Modbus Address' (1), 'Transmit Controls' (checked), and 'Modbus Type' (RTU selected, Ascii unselected). At the bottom of the wizard are buttons for '<< Back', 'Finish', 'Save', 'Cancel', and 'Help'.

Settings for Ethernet (Option ETH)

Local IP Address

This is the static IP address to be assigned to the annunciator so that it can be located on a network.

Remote IP Address

When the annunciator is operating in Master mode this is the address to which it will send data requests.

Subnet Mask

To allow the annunciator to be successfully connected to your network you will have to provide the correct subnet mask. If you do not know the correct subnet mask then you should contact your network administrator.

Default Gateway

Please contact your network administrator to find out whether you need to set a gateway to successfully connect to your network.

Port Address

Select the Port Address of the host system on the network.

Common Modbus Settings

Modbus Address

In master mode, this is the address of the slave annunciator that the master will connect to. In slave mode this address is the annunciators own local Modbus address. Every system on a common serial bus must be given a unique address. Valid addresses are from 1 to 255.

Receive & Transmit Start Address

This defines the base register address for sending and receiving information.

Parity

The parity for the serial communications may be selected from:-

- None
- Odd
- Even

The configuration application will always use the parity defined for the SERIES 90A. If the parity is changed it will not take affect until the current configuration session is complete.

Baud Rate

The Modbus baud rate may be selected from :-

- 1200
- 2400
- 4800
- 9600
- 19200

The configuration application will always use the baud rate defined for the SERIES 90A. If the baud rate is changed it will not take affect until the current configuration session is complete.

Modbus Mode

The Modbus Mode may be selected from:-

- Master
- Slave

A Master unit may issue command functions and a slave unit responds to them. When the SERIES 90A configuration application is being used the SERIES 90A will be in slave mode independent of its Mode setting.

Data Type

The Modbus Data Type may be selected from:-

- AN3135 Point State
- Point
- State

Reference Appendix A for a complete description of these Data Types.

Slave Address

This is used when the SERIES 90A is selected as a Modbus Master. The Slave Address refers to the device that the Master is communicating to. Valid addresses are from 1 to 255.

Transmit Controls

If this option is selected, Acknowledge and Reset Pushbutton controls will be transmitted along with point data. (When communicating between two Annunciators, only one Annunciator may be set to Transmit Controls. As a default, the Annunciator will always accept or receive pushbutton controls from another device regardless if the Transmit Controls option is selected.

Modbus Type

This is a format in which the data is transmitted. Can be set to ASCII or RTU.

DNP3.0

The screenshot shows the 'Annunciator Setup Wizard' window with the 'DNP 3.0' tab selected. The window contains several configuration sections:

- Ethernet:** Local IP Address (192 . 168 . 0 . 1), Remote IP Address (192 . 168 . 0 . 1), Subnet Mask (255 . 255 . 255 . 0), Default Gateway (0 . 0 . 0 . 0), and Port Address (20000).
- Comms Port:** Baud Rate (9600).
- Transmission:** IED Address (25) and Transmission Delay (10).
- Data Link Confirm:** Confirm Mode (Never), Retries (3), Timeout (10), and Select/Operate Arm Timer (0).

Navigation buttons include '<< Back', 'Next >>', 'Save', 'Cancel', and 'Help'.

Note: These options will only be available if the DNP3.0 functionality has been purchased from AMETEK. The DNP3.0 option is currently only available on the SERIES 90A annunciators. The default DNP settings are given in Appendix C.

Settings for Ethernet (Option ETH)

Local IP Address

This is the static IP address to be assigned to the annunciator so that it can be located on a network.

Remote IP Address

When the annunciator is operating in Master mode this is the address to which it will send data requests.

Subnet Mask

To allow the annunciator to be successfully connected to your network you will have to provide the correct subnet mask. If you do not know the correct subnet mask then you should contact your network administrator.

Default Gateway

Please contact your network administrator to find out whether you need to set a gateway to successfully connect to your network.

Port Address

Select the Port Address of the host system on the network.

Common DNP Configuration Settings

IED Address

This is a number used to identify the recorder on the network (range 1 - 65534).

Transmission delay

This is the time to disable the master transmitter on an RS485 network (range 0 - 65535) (not currently used).

Data Link Confirm

This can be set as Never, Sometimes or Always. The default value is Never.

Retries

This is the number of times the recorder will retry to connect if Data Link confirmation is required (range 0 - 255)

Timeout

This is the time the IED will wait for a Data Link confirmation. Valid numbers are 0 - 65535.

Select/Operate arm time

This is the time period after the select command is received that the operate command will be performed (range 0 - 65535) (Not currently used)

Communications port

The Baud rate of the recorder's serial port can be set by selecting a value from the Baud rate drop down list box. The DNP baud rate may be selected from :-

1200
2400
4800
9600
19200

Quick Access

Toolbar

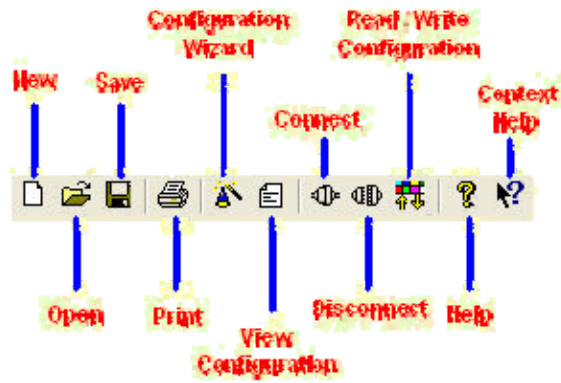

Hot Keys

Action	Hot Key
New Document	CTRL + N
Open Document	CTRL + O
Save	CTRL + S
Print Configuration	CTRL + P
View Configuration	CTRL + V
Connect	CTRL + C
Disconnect	CTRL + D
Create Duplicate	CTRL + R
Connection Status	CTRL + T
Run Wizard	CTRL + W

SYSTEM SPECIFICATIONS

INPUTS

Field Contacts

Normally Open (N.O.) or Normally Closed (N.C.)
Input selection through Software or Field Selectable Jumper
Wet (voltage supplied) or dry (voltage free) contacts

Field Contact Voltage (FCV)

Common FCV or FCV Isolated Input to Input (Jumper Selectable)
12, 24, 48, 125 VDC, 120 VAC or 24VDC open collector
Input Current Requirement: 0.0018 mA per input
FCV Disconnect for an alarm when the I/O Module is removed (other alarms unaffected)

Input Isolation

Each input is optically isolated

Input Response

1 millisecond	(Fast Response, Option FR. Also used with SER option)
50 milliseconds	Standard Response
50 msec to 250 seconds	Adjustable in Software in 50 msec or 1 second increments

Display

Window Sizes

Full Size (1 per Cell):	3.0 x 3.0"	(76 x 76mm)
Half Size (2 per Cell):	1.5 x 3.0"	(38 x 76mm)
Third Size (3 per Cell):	1.0 x 3.0"	(25 x 76mm)
Quad Size (4 per Cell):	1.5 x 1.5"	(38 x 38mm)

Illumination

White LED 20 mA @5VDC

Full Size Windows	8 LED's / Input
Half Size Windows	4 LED's / Input
Third Size Windows	2 LED's / Input
Quad Size Windows	2 LED's / Input

Window Color

White, Red, Yellow, Amber, Green, Blue

Legends

Laser printed on transparency film or Engraved

Repeat Relay Outputs

Repeat Relay Option RR

Individual relay per point

Follows field contact or alarm sequence, selectable in Software
Energized or de-energized Relay Coil, selectable in Software
Form A or Form B (N.O. or N.C.) Contact, selectable by Jumper
-Available with all window sizes

Repeat Relay Option 2RR

Two repeat relays per point

Follows field contact or alarm sequence, selectable in Software
Energized or de-energized Relay Coil, selectable in Software
Form A or Form B (N.O. or N.C.) Contact, selectable by Jumper
-Available with full or half size (option 2S) windows

Repeat Relay Option FRC

Individual repeat relay per point

Follows field contact or alarm sequence, selectable in Software
Energized or de-energized Relay Coil, selectable in Software
Form C (SPDT) Contact, selectable by Jumper
-Available with full or half size (option 2S) windows

Relay Operation

Follows Field Contact:	Repeat Relay Output Follows Input Contact State
Follows Alarm Sequence:	Repeat Relay Output Latches on Alarm until Acknowledged or Reset
Follows Alarm Display:	Repeat Relay Output toggles on and off following operation of window

Relay operation selectable in Software per point

Relay Ratings:

24VDC @ 3.0 Amps
110VDC @ 0.1 Amps
120VAC @ 3.0 Amps
Resistive Load

Alarm Sequence

Sequence Selections Up to 4 Sequences per system (configured in software by input)

LN	Automatic reset, non-locking, no flash, no audible, no PB
AO	Automatic reset with lock-in of alarms, no flash
AONL	Automatic reset, non locking, no flash
AF	Automatic reset with lock-in of alarms
AFNL	Automatic reset, non locking
FR	Automatic reset with lock-in of alarms, flash reset
AM	Manual Reset with lock-in of alarms
FRM	Manual Reset with lock-in of alarms, flash reset
AS	First out fast flash, subsequent alarm steady, auto reset
ASFR	First out fast flash, subsequent alarm steady, auto reset, w/ silence
ASFRM	First out fast flash, subsequent alarm steady, first out reset, w/ silence
TFS	First out, triple flash, first out reset
TFSFRM	First out, triple flash, first out reset, flash reset, reset
TFSM	First out, triple flash, first out reset, reset
ARR	Ringback, dual flash, lock-in of alarms until acknowledged
FRR	Ringback, dual flash, lock-in of alarms until acknowledged, flash reset
VS	First out, dual color, single flash, with first out reset
VSRR	First out with ringback, dual color, dual flash, with first out reset, reset
MC	Motor Control

Customized flash rates

100 millisecond increments (Selectable in Software)

First Out Groups

Up to 4 first out groups per system

5 millisecond First Out Discrimination

Lamp Synchronization

Synchronize other displays to same flash rate. Master system outputs a pulse at the slow flash rate. Slaves re-sync to incoming "lamp off" edge. A master system may drive up to 5 slave units.

Controls

Pushbuttons

Integral Pushbutton Option (INTB): Test, Acknowledge, Silence and Reset
(4) External Pushbutton Inputs: Test, Acknowledge, Silence and Reset
5VDC @0.002 mA per Pushbutton
(provided by Annunciator)

Switch Input (Option SW)

Software configurable for:
Inhibit of LED Lamps, Horn, Repeat Relay Outputs or CSM Common Relay
Outputs
5VDC @0.002 mA (provided by Annunciator)

System Relays

Alarm Grouping

Critical or Non-Critical Alarms: Selectable in software per input
Used to provide separate horns, or other relay outputs
Critical Alarms have priority over Non-Critical (can be disabled)

Standard Relays

(2) Relays Software Configurable for:
Critical or Non-Critical Horn, Ringback Horn
Energized or De-Energized Relay Coil, selectable in Software
Form A or Form B (N.O. or N.C.) Contact, Selectable by Jumper

Optional Relays (Option RLY)

(2) Additional Relays Software Configurable for:
Critical or Non-Critical Horn, Ringback Horn, Critical or Non-Critical Reflash,
Critical or Non-Critical Fault, Power Fail, System Watchdog, or Ground Fault
Detect)
Energized or De-Energized Relay Coil, selectable in Software
Form A or Form B (N.O. or N.C.) Contact, Selectable by Jumper

Relay Ratings:

24VDC @ 3.0 Amps
110VDC @ 0.1 Amps
120VAC @ 3.0 Amps
Resistive Load

Audible Devices

Internal 80db @ 30cm audible device (option HN)
External Audible Devices available

Communications

Communication Options

Function	Option SIM	Option MB	Option DNP	Option SD
	Modbus Input Only	Modbus Input & Output	DNP Output	Serial ASCII Output
Transmit Alarm Status via Serial Data	No	Yes	Yes	Time stamped alarms only
Receive Alarm Status via Serial Data	Yes	Yes	No	No
RTU or ASCII Mode	Yes	Yes	N/A	N/A
Master Mode	Yes	Yes	No	N/A
Slave Mode	Yes	Yes	Yes	N/A
Transmit Local Pushbutton Controls	Yes	Yes	Yes	No
Receive Remote Pushbutton Controls	Yes	Yes	Yes	No
RS-232 / 485	Yes	Yes	Yes	Yes
Ethernet (Option ET)	Yes	Yes	Yes	Yes

Time Stamped Alarms

Sequential Events Recording

(Option SER, SERFR)

Time Stamp Resolution:

1 or 4 millisecond (depending on option selected)

Time Set Method:

Through Configuration Software

Time Synchronization:

Internal Clock (accurate to 10 seconds per day)

Optional IRIG-B Module (accurate to 1msec)

Data Output:

Modbus, DNP or ASCII

Data Format:

Point Number, Point Status, Time & Date of alarm and subsequent return to normal.

Event Storage:

500 Events

(an event can be a point on alarm or a point that returns to normal)

Power Requirements

Input Power

19-29 VDC

(Option F

24VDC)

38-58 VDC

(Option E

48VDC)

100-250 VDC

(Option C

125VDC)

88-132 VAC, 60 Hz

(Option B

120VAC)

176-264 VAC, 50 Hz

(Option A

230VAC)

Input Burden: Maximum 2.2 Watts/point (depends on window size and options selected)

Mechanical

Enclosures: Semi-flush Panel Mount,
 19" Rack Mount,
 Surface (wall) mount,
 NEMA Enclosures

Size: Depends on Annunciator Configuration (# of cells high x wide)

Weight: 1.5 LB per cell (0.8kg per cell)

Connections / terminations

Field Contact Input, Relay Output, Power Input Terminals

- Barrier Terminal Block, #6-32 screw. Accepts Ring, Spade Lug or Bare Wire
- Wire size: 12-22 AWG

Pushbutton/Switch Input, Lamp Synchronization Terminals

- Barrier Terminal Block, #6-32 screw. Accepts Ring, Spade Lug or Bare Wire
- Wire size: 14-22 AWG

Serial Communication Port(s)

- 9 Pin Female D connector

Ethernet Communication Port

- RJ45 connector

IRIG-B Time Synchronization Input

- BNC connector

Environment

Operating Temperature Range:	-20 TO 50 OC (-4 to 122oF)
Storage Temperature Range:	-20 TO 80 OC (-4 to 176oF)
Humidity:	20-95% RH

Electrical

Surge Withstand:	ANSI C37.90.1 (Oscillatory portion)
Electrical Fast Transient/Burst Immunity:	
IEC 61000-4-4	(2kV DC Power, 1kV I/O)
Surge Immunity:	IEC 61000-4-5 (1kV Common Mode, line-to-ground)

Dielectric Withstand:

- 1400 Vac or 2050 Vdc Inputs to Digital (test @ configuration port)
- 1400 Vac or 2050 Vdc Outputs to Digital (test @ configuration port)
- 1450 Vac or 2150 Vdc AC Integral Power Input to Digital (test @ configuration port)
- 350 Vac or 500 Vdc DC Integral Power Input to Digital (test @ configuration port)
- 1400 Vac or 2000 Vdc from Inputs to Outputs
- 1400 Vac or 2000 Vdc from Inputs to Power Input
- 250 V RMS from Input to Input when configured for Isolated Inputs
- 1400 Vac or 2000 Vdc from Outputs to Power Input
- 1200 Vac or 1700 Vdc from Output to Output
- 1400 Vac or 2000 Vdc from Inputs to Case
- 1200 Vac or 1700 Vdc from Outputs to Case
- 1400 Vac or 2000 Vdc from Integral AC Power to Case
- 350 Vac or 500 Vdc from Integral DC Power to Case
- 350 Vac or 500 Vdc from Communications Ports to DC Power
- 1450 Vac or 2150 Vdc from Communications Ports to AC Integral Power Input

Radiated RFI Immunity:	IEC 61000-4-3 10 V/m
Conducted RFI Immunity:	IEC 61000-4-6 3V
Radiated Emissions:	EN 61000-6-4 (EN55011)
Conducted Emissions:	EN 61000-6-4 (EN55011)
Radiated Power Frequency:	IEC 61000-4-8 30 A/m Magnetic Field
ESD Effects:	IEC 61000-4-2 4kV contact 8kV air

Certifications

CE:	Low Voltage Directive 73/23/EEC:	EN 61010-1:2001
	EMC Directive 89/336/EEC:	EN 61326:1998
FM ¹	Class 1, Division 2, groups A, B, C, and D	
FM-C ¹	(FM Canada)	
UL:	2017	
ULC:	(UL Canada)	
ULR		
CSA		

¹ *Requires FM option (refer to option codes). The required door may be supplied by Ametek, a panel shop or the customer. The door must meet the FM standard for requiring a tool to open or remove the door to allow access to the front of the Annunciator.*

Servicing

Ensure that the power supply to the unit is switched off before servicing.

MODULE REMOVAL

When removing a module for replacement or configuration, it is best to shut off the power to prevent any false alarms or electric shock. When replacing any board, note the jumper settings and transfer them to the replacement module. If in doubt, refer to the module set-up instructions in this manual.

CAUTION

Note and record the window positions when removed from the chassis so as to ensure that the windows are replaced in their original locations

Severe problems/damage could occur to monitored plant/equipment should windows be replaced in incorrect positions causing erroneous indication of alarms

Only remove one window assembly at a time to minimise the possible incorrect repositioning of alarm display windows

ESD

ESD (Electrostatic Discharge) can damage sensitive electronics when they are being handled or touched. The Annunciator has been protected against certain levels of ESD when touching the outside case or terminals. The internal electronics may be susceptible to ESD when handled, so proper care should be given to any exposed electronics or circuit boards. The following guidelines should be used to prevent any build-up of ESD and to minimize the products exposure to it.

1. Prevent static build-up by using conductive paints, carpeting, mats and metal surfaces. Use appropriate grounding techniques, including wrist and heel straps for personnel.
2. Store or transport electronic devices, parts and assemblies in conductive bags or bins.
3. Only perform repairs at an appropriate repair station.
4. When handling electronic assemblies or printed circuit boards try to avoid touching traces on the printed circuit board or the static sensitive devices.
5. Remember that tools are a source of static electricity. Only use grounded soldering irons. Ground tools before using them to bleed off any charge build-up.
6. Discharge yourself before touching or handling any electronic assembly or device. This can be done by touching a good ground point before touching any electronic devices or assemblies. Preferably, discharge any static charge through a high impedance such as a wrist or heel strap.

APPENDIX A

OPERATIONAL SEQUENCES

The following are summary sequence descriptions provided for guidance.

AUTO RESET, NON LOCKING STATUS ONLY INDICATION, NO AUDIBLE				
SEQUENCE CODE	ALARM DEVICE	NORMAL	ALARM	RETURN TO NORMAL
LN	VISUAL			
	ISA-A-4-5-6			

AUTO RESET, LOCKING, NO FLASH						
SEQUENCE CODE	ALARM DEVICE	NORMAL	ALARM	ACKNOWLEDGE	RETURN TO NORMAL	RETURN TO NORMAL BEFORE ACK
AO	VISUAL					
	ISA-A-5					

AUTO RESET, NON LOCKING, NO FLASH						
SEQUENCE CODE	ALARM DEVICE	NORMAL	ALARM	ACKNOWLEDGE	RETURN TO NORMAL	RETURN TO NORMAL BEFORE ACK
AONL	VISUAL					
	ISA-A-4-5					

AUTO RESET, LOCKING							
SEQUENCE CODE	ALARM DEVICE	NORMAL	ALARM	ACKNOWLEDGE	RETURN TO NORMAL	RETURN TO NORMAL BEFORE ACK	ACKNOWLEDGE
AF	VISUAL						
	ISA-A						

AUTO RESET, NON-LOCKING						
SEQUENCE CODE	ALARM DEVICE	NORMAL	ALARM	ACKNOWLEDGE	RETURN TO NORMAL	RETURN TO NORMAL. BEFORE ACK
AFNL	VISUAL					
ISA-A-4	AUDIBLE					

AUTO RESET, LOCKING, WITH FLASH RESET									
SEQUENCE CODE	ALARM DEVICE	NORMAL	ALARM	ACKNOWLEDGE	FLASH RESET	RETURN TO NORMAL	RETURN TO NORMAL. BEFORE ACK	ACKNOWLEDGE	FLASH RESET
FR	VISUAL								
	AUDIBLE								

MANUAL RESET, LOCKING								
SEQUENCE CODE	ALARM DEVICE	NORMAL	ALARM	ACKNOWLEDGE	RETURN TO NORMAL	RETURN TO NORMAL. BEFORE ACK	ACKNOWLEDGE	RESET
AM	VISUAL							
ISA-M	AUDIBLE							

MANUAL RESET, LOCKING, WITH FLASH RESET									
SEQUENCE CODE	ALARM DEVICE	NORMAL	ALARM	ACKNOWLEDGE	FLASH RESET	RETURN TO NORMAL	RETURN TO NORMAL. BEFORE ACK	ACKNOWLEDGE	FLASH RESET
FRM	VISUAL								
	AUDIBLE								

FIRST OUT, FAST FLASH, LOCKING, AUTORESET												
SEQUENCE CODE	ALARM DEVICE	NORMAL	ALARM		ACKNOWLEDGE		RETURN TO NORMAL		RETURN TO NORMAL BEFORE ACK.		ACKNOWLEDGE	
			INITIAL	NEXT	INITIAL	NEXT	INITIAL	NEXT	INITIAL	NEXT	INITIAL	NEXT
AS	VISUAL											
ISA-F1-A	AUDIBLE											

FIRST OUT, FAST FLASH, LOCKING, AUTORESET WITH SILENCE														
SEQUENCE CODE	ALARM DEVICE	NORMAL	ALARM		SILENCE		ACKNOWLEDGE		RETURN TO NORMAL		RETURN TO NORMAL BEFORE ACK.		ACKNOWLEDGE	
			INITIAL	NEXT	INITIAL	NEXT	INITIAL	NEXT	INITIAL	NEXT	INITIAL	NEXT	INITIAL	NEXT
ASFR	VISUAL													
ISA-F1-A	AUDIBLE													

FIRST OUT, FAST FLASH, LOCKING, FIRST OUT RESET WITH SILENCE																
SEQUENCE CODE	ALARM DEVICE	NORMAL	ALARM		SILENCE		ACKNOWLEDGE		RETURN TO NORMAL		RETURN TO NORMAL BEFORE ACK.		ACKNOWLEDGE		RESET	
			INITIAL	NEXT	INITIAL	NEXT	INITIAL	NEXT	INITIAL	NEXT	INITIAL	NEXT	INITIAL	NEXT	RESET	
ASFRM	VISUAL															
ISA-F2M-1	AUDIBLE															

FIRST OUT, TRIPLE FLASH, FIRST OUT RESET													
SEQUENCE CODE	ALARM DEVICE	NORMAL	ALARM		ACKNOWLEDGE		RETURN TO NORMAL		RETURN TO NORMAL BEFORE ACK.		ACKNOWLEDGE		FIRST OUT
			INITIAL	NEXT	INITIAL	NEXT	INITIAL	NEXT	INITIAL	NEXT	INITIAL	NEXT	RESET
TFS	VISUAL												
ISA-F3A	AUDIBLE												

FIRST OUT, TRIPLE FLASH, FIRST OUT RESET, RESET													
SEQUENCE CODE	ALARM DEVICE	NORMAL	ALARM		SILENCE		ACKNOWLEDGE (FLASH RESET)		FIRST OUT RESET		RETURN TO NORMAL		RESET
			INITIAL	NEXT	INITIAL	NEXT	INITIAL	NEXT	INITIAL	NEXT	INITIAL	NEXT	RESET
TFSFRM	VISUAL												
	AUDIBLE												

Note: The RESET and FIRST OUT RESET Pushbuttons are combined together at the same terminal.

FIRST OUT, TRIPLE FLASH, FIRST OUT RESET, RESET											
SEQUENCE CODE	ALARM DEVICE	NORMAL	ALARM		ACKNOWLEDGE		FIRST OUT RESET		RETURN TO NORMAL		RESET
			INITIAL	NEXT	INITIAL	NEXT	INITIAL	NEXT	INITIAL	NEXT	RESET
TFSM	VISUAL										
	AUDIBLE										

Note: The RESET and FIRST OUT RESET Pushbuttons are combined together at the same terminal.

RINGBACK, DUAL FLASH, LOCK IN UNTIL ACKNOWLEDGED						
SEQUENCE CODE	ALARM DEVICE	NORMAL	ALARM	ACKNOWLEDGE	RETURN TO NORMAL	RESET
ARR	VISUAL					
ISA-R	AUDIBLE					

* Ringback Audible

RINGBACK, DUAL FLASH, LOCK IN UNTIL ACKNOWLEDGED								
SEQUENCE CODE	ALARM DEVICE	NORMAL	ALARM		ACKNOWLEDGE (FLASH RESET)	RETURN TO NORMAL		RESET
FRR	VISUAL							
	AUDIBLE							

* Ringback Audible

FIRST OUT, SINGLE FLASH DUAL COLOR WITH FIRST OUT RESET									
SEQUENCE CODE	ALARM DEVICE	NORMAL	ALARM		ACKNOWLEDGE		RETURN TO NORMAL		FIRST OUT RESET
			INITIAL	NEXT	INITIAL	NEXT	INITIAL	NEXT	
VS	VISUAL								
	AUDIBLE								

Dual Lamp Sequences use only one input on each input card for a maximum of 2 alarms per window cell.











Window Size 2 provides 1 alarm/cell, size 2S,2E & 4 provide 2 alarms/cell.

FIRST OUT, DUAL FLASH, DUAL COLOR, FIRST OUT RESET, RESET											
SEQUENCE CODE	ALARM DEVICE	NORMAL	ALARM		ACKNOWLEDGE		RETURN TO NORMAL		RESET		FIRST OUT RESET
			INITIAL	NEXT	INITIAL	NEXT	INITIAL	NEXT	INITIAL	NEXT	
VSRR	VISUAL										
	AUDIBLE										

* Ringback Audible

Dual Lamp Sequences use only one input on each input card for a maximum of 2 alarms per window cell.

Window Size 2 provides 1 alarm/cell, size 2S,2E & 4 provide 2 alarms/cell.

MOTOR CONTROL						
SEQUENCE CODE	ALARM DEVICE	MOTOR ON	ALARM	ACKNOWLEDGE	MOTOR RESTART	MANUAL STOP
MC	VISUAL		 FAST	 SLOW		
	AUDIBLE					

Note: The Manual Stop function is provided through the Reset Pushbutton. It is a common control for the entire system and provides a manual stop indication (lamps and horn off) to all inputs in the alarm state.

For intermixed sequences specify IMO order code

LEGEND

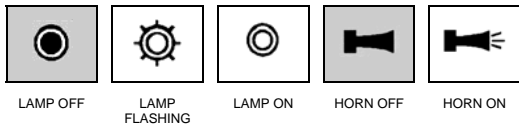

APPENDIX B

MODBUS DATA FORMATS

The system has the capability of operating with three distinct data formats: fault mode, alarm state mode and AN3135 mode. The latter is designed to be compatible with existing AN-3100C Modbus installations. All these formats are embedded within Modbus data registers for transmission and reception.

A selection of Modbus function may be used and these vary depending on the whether the SERIES 90A is operating as Modbus master or slave.

Function	Description	Data Units	Data Direction		SERIES 90A Supported Mode
			Master	Slave	
3	Read Holding Registers	Words	Input	Output	Master or slave
6	Preset Single Register	Words	Output	Input	Slave only
7	Read Exception Status	Bytes	Input	Output	Slave only
16	Preset Multiple Registers	Words	Output	Input	Master or slave
17	Report Slave ID	Bytes	Input	Output	Slave only

A function value of 03 (Read Holding Registers) is set to read alarm data from the system (in slave configuration). Function values 06 (Preset Single Register) and 16 (Preset Multiple Registers) are used to write fault and control data. Single and multiple register writes are supported. Exception status responses (function 07) and Slave ID (function 17) are also supported. Exception codes for unrecognized received messages are also included.

The Modbus functions are enabled by a software switch and require a key to enable them, which is supplied by AMETEK. This may be done prior to delivery or retrofitted to installed systems.

Alarm State Mode

The system can provide data reflecting the alarm state of the system. This mode operates as output only (transmit alarms) from the system.

The alarm state data is present within a 16 bit register format as shown in the table below. The data is in a nibble format (4 bits per point, 4 points per register) and reflects the already established DMS3000/RTU3000 style format. Note the control transfer is not supported in this mode as the control state of any point is included within the data transferred.

Bit

Point 1, First up, unacknowledged

Point 1, Subsequent up, unacknowledged

Point 1, Acknowledged

Point 1, Fault

The data layout is as shown below.

Word	Bit15-bit12	Bit11-bit8	Bit7-bit4	Bit3-Bit0
1	AP 04	AP 01
..
60	AP 240	AP 237

Point Mode

The system can present or accept (transmit or receive) raw field input point data plus alarm controls. Single and multiple register writes are supported. Data is again presented in a 16 bit register format. The last word of a transfer of input data may optionally contain control data.

The data layout for a sample system configured for point data will be as below.

Word	Bit15	Bit6	Bit5	Bit4	Bit3	Bit2	Bit1	Bit0
1	AP 16			AP 01
..
15	AP 240			AP 225
16							Ack Rec	Rst Rec	Ack Tran	Rst Tran

AP refers to Alarm Point Channel. ACK refers to the Acknowledge Pushbutton and RST refers to the RESET Pushbutton.

The local pushbutton controls (on the front of the Annunciator and other ones connected to the external pushbutton inputs) can be transmitted (Tran) to a remote device using Ack Tran and Rst Tran as shown. The Annunciator can also receive (Rec) the pushbutton controls from the remote device using Ack Rec and Rst Rec as shown.

AN3135 Mode

The system has the capability of mimicking the existing AN-3100C Modbus functionality. The object is to provide a system that is backwards compatible with the existing AN-3135 Modbus Module used on AN-3100C systems. The AN3135 mode is restricted to the default Functions of 03 to read alarm data and 06 and 16 being used to write fault and control data. The principal difference between this and the point mode above is that the AN3135 mode is restricted to 64 points.

The data layout for a sample system configured for point data will be as below.

Word	Bit15	Bit6	Bit5	Bit4	Bit3	Bit2	Bit1	Bit0
1	AP 16			AP 01
..
4	AP 64			AP 49
5							Ack Rec	Rst Rec	Ack Tran	Rst Tran

AP refers to Alarm Point Channel. ACK refers to the Acknowledge Pushbutton and RST refers to the RESET Pushbutton.

The local pushbutton controls (on the front of the Annunciator and other ones connected to the external pushbutton inputs) can be transmitted (Tran) to a remote device using Ack Tran and Rst Tran as shown. The Annunciator can also receive (Rec) the pushbutton controls from the remote device using Ack Rec and Rst Rec as shown.

Event Data

Event data may be read in blocks of 10 events at a time. These appear in a block of 60 registers (6 per event) located at the configured Start Address plus 1000 i.e. if the Start Address is set to 40001 then the events appear at 41001-41060. Once ten events are read then the registers are reloaded with any subsequent ones from the 500 event buffer. If no event has occurred, then all 12 bytes are filled with FF HEX.

The event data format is as shown below:

Word	MSB	LSB
1	Year	Month
2	Day	Hour
3	Minute	Second
4	Millisecond (0-999)	
5	0x00	Input Point No.
6	IRIG-B Sync	1 = Point on 0 = Point off

An example of the register format for the 10 events is shown below:

Event Data		
41001	1st Event	Year (0-99) high byte / Month (1-12)low byte
41002		Day of month (1-31)high byte /Hours (0-23) low byte
41003		Minutes (0-59) high byte / Seconds (0-59) low byte
41004		Milliseconds (0-999) two bytes
41005		SERIES 90A Point Number (1-198)
41006		IRIG-B Sync – high byte / Point Status (1 = A, 0 = N) low byte
41007	2nd Event	Year (0-99) high byte / Month (1-12)low byte
41008		Day of month (1-31)high byte /Hours (0-23) low byte
41009		Minutes (0-59) high byte / Seconds (0-59) low byte
41010		Milliseconds (0-999) two bytes
41011		SERIES 90A Point Number (1-198)
41012		IRIG-B Sync – high byte / Point Status (1 = A, 0 = N) low byte
41054	10th Event	Year (0-99) high byte / Month (1-12)low byte
41056		Day of month (1-31)high byte /Hours (0-23) low byte
41057		Minutes (0-59) high byte / Seconds (0-59) low byte
41058		Milliseconds (0-999) two bytes
41059		SERIES 90A Point Number (1-198)
41060		IRIG-B Sync – high byte / Point Status (1 = A, 0 = N) low byte

* Supports Master or Slave Mode, Transmit only

Modbus Addresses

Conventional addresses are included in the configuration. The input and output functions here are the most commonly used and refer to a system in slave configuration.

Conventional Start address	Data	Input Functions	Output Functions
00000	Output Coils	05,15	01
10000	Discrete Inputs		02
30000	Input Registers		04
40000*	Holding (output) Registers	06,16	03
60000	Extended Memory		

*Supported in the SERIES 90A

Default Values

Designation	Options	Default	Comments
Modbus Address	0-255	01	
Receive Start Address	40001-49999	40001	Register address entry.
Transmit Start Address	40001-49999	40001	
Modbus Mode	Master/Slave	Slave	
Data type	AN3135 /Point/State	Point	An3135 mimic, point or alarm state data.
Baud rate	2400/4800/9600/19200	9600	
Parity	Odd/Even/none	None	Parity type
Transmit controls	Yes/No		Send alarm control (ACK, RST) data
Data direction	Input/output	Output	1 bit per point to designate Tx/Rx data
Modbus format	ASCII/RTU	RTU	

APPENDIX C

DNP DATA FORMATS

The DNP Communication option is used to transmit point status (Binary Inputs) to other devices. When the SER time-stamped alarms option is enabled, a historical record of binary input change events and the time at which they occurred can also be sent. The DNP Communications work in a slave mode and operate over RS-232/485 or Ethernet. The DNP implementation is outlined in the Device Profile Document.

DEVICE PROFILE DOCUMENT

DNP V3.0	
DEVICE PROFILE DOCUMENT	
Vendor Name: AMETEK Power Instruments	
Device Name: AN3100D, using the Triangle MicroWorks, Inc. DNP3 Multi-Port Slave Source Code Library	
Highest DNP Level Supported: For Requests: Level 2 For Responses: Level 2	Device Function: Slave
<p>Notable objects, functions, and/or qualifiers supported in addition to the Highest DNP Levels Supported (the complete list is described in the attached table):</p> <p>For static (non-change-event) object requests, request qualifier codes 00 and 01 (start-stop), and 17 and 28 (index) are supported in addition to request qualifier code 06 (no range – or all points). Static object requests received with qualifiers 00, 01 or 06, will be responded to with qualifiers 00 or 01. Static object requests received with qualifiers 17 or 28 will be responded to with qualifiers 17 or 28. For change-event object requests, qualifier codes 06 (no range) and 07 and 08 (limited quantity) are supported. Qualifiers 17 or 28 are always returned.</p>	
Maximum Data Link Frame Size (octets): Transmitted: 292 Received 292	Maximum Application Fragment Size (octets): Transmitted: 170 Received 50
Maximum Data Link Re-tries: Configurable from 0 to 255	Maximum Application Layer Re-tries: None
Requires Data Link Layer Confirmation: Configurable as: Never, Only for multi-frame messages, or Always	
Requires Application Layer Confirmation: When sending multi-fragment responses (Slave devices only) Sometimes	

DNP V3.0

DEVICE PROFILE DOCUMENT

Timeouts while waiting for: Data Link Confirm: Configurable. Complete Appl. Fragment: None Application Confirm: Configurable. Complete Appl. Response: None Others: Transmission Delay, configurable Inter-character Timeout, 1 second Need Time Delay, configurable Frozen Counter Change Event Scan Period, Fixed at 1 second	
Sends/Executes Control Operations: WRITE Binary Outputs Never SELECT/OPERATE Never DIRECT OPERATE Never DIRECT OPERATE – NO ACK Never Count > 1 Never Pulse On Never Pulse Off Never Latch On Never Latch Off Never Queue Never Clear Queue Never	
Reports Binary Input Change Events when no specific variation requested: Never	Reports time-tagged Binary Input Change Events when no specific variation requested: Never
Sends Unsolicited Responses: Never	Sends Static Data in Unsolicited Responses: Never No other options are permitted.
Default Counter Object/Variation: Default Object 1 Default Variation: 1	Counters Roll Over at: No Counters Reported
Yes	

IMPLEMENTATION TABLE

OBJECT			REQUEST	RESPONSE	
Object Number	Variation Number	Description	Function Codes (decimal)	Function Codes (decimal)	Qualifier Codes (hex)
1	1	Binary Input	1 (read)	129 (response)	00, 01 (start-stop)

PUSHBUTTON CONTROLS

Pushbutton activation can be transmitted from the Annunciator via a Binary input to indicate whenever a pushbutton is activated locally at the Annunciator. (Reference the Binary Input Data Map for location of the pushbutton indications.)

Pushbutton controls can be sent to the Annunciator using a Control Relay Output block, as detailed below.

Control Relay Output Block (Object 12, variation 2)

Index #	DNP Object		Control Code	Description
	Object Number	Variation Number		
00	10	02	LON, LOFF *	Reset Pushbutton
01	10	02	LON, LOFF *	Acknowledge Pushbutton
For proper pushbutton operation, transmit a single LON (latch on) followed by a single LOFF (latch off). Allow a few seconds in between commands to ensure the Annunciator receives the pushbutton controls.				
Mode: Direct 16 Bit Index				

The Pushbutton Control Status can be checked by issuing a Binary Output Status, Object 10, variation 2.

Binary Output Status (Object 10, Variation 2)

Index #	DNP Object		Description
	Object Number	Variation Number	
00	10	02	Reset Pushbutton
01	10	02	Acknowledge Pushbutton

SERIES 90A DATA MAP

Binary Inputs

The Annunciator alarms are presented as binary inputs as shown below.

Index #	DNP Object		Description
	Object Number	Variation Number	
00	01	00	Point 1 Digital Contact Alarm
01	01	00	Point 2 Digital Contact Alarm
02	01	00	Point 3 Digital Contact Alarm
03	01	00	Point 4 Digital Contact Alarm
04	01	00	Point 5 Digital Contact Alarm
05	01	00	Point 6 Digital Contact Alarm
06	01	00	Point 7 Digital Contact Alarm
07	01	00	Point 8 Digital Contact Alarm
08	01	00	Point 9 Digital Contact Alarm
09	01	00	Point 10 Digital Contact Alarm
10	01	00	Point 11 Digital Contact Alarm
196	01	00	Point 197 Digital Contact Alarm
197	01	00	Point 198 Digital Contact Alarm
198	01	00	Point 199 Digital Contact Alarm
199	01	00	Point 200 Digital Contact Alarm
200	01	00	Acknowledge Pushbutton
201	01	00	Reset Pushbutton

Binary Input Change with Time (SER Option)

The time stamped alarms are presented as Binary Input Changes with Time when the SER Option is provided.

DNP Object		Description
Object Number	Variation Number	
02	02	Digital Contact Alarm w/time of event

APPENDIX D

WINDOW ASSEMBLY DETAILS

The Annunciator uses a common window assembly for all window configurations. The different window options are created using dividers (for the 4 window sizes) and colored filters for the different window colors (white, red, blue, green, amber, yellow). The assembly drawings on the next page identify the different options available.

A typical window consists of the following parts:

- Transparency film with Legends
- Colored Filter if required (red, blue, green, amber, yellow)
- White Diffusers (to eliminate LED hotspots)

All of these parts are pressed into the clear window, which is inserted into the window frame.

Window Legends

The Annunciator Window Legends are typically printed on clear transparency film, which is provided with the Annunciator. There is an option to engrave these legends directly on the window (Option E). For printing of legends on the transparency film, the Software CD will include a template in Microsoft Excel. You type the legend in the window template that matches your size window and print on a suitable printer. (A laser printer is recommended or any type that is compatible with printing on Transparency film.)

Window Colors

The Annunciator Window Colors are provided through colored filters, which are provided with the Annunciator. In cases where several different window colors are required for an individual Cell (option IMC), the laser printed transparency will be colored in place of the color filters. In these cases, color Laser Printer should be used.

Note: All legends and pre-printed colors will be provided with the Annunciator if the details are provided before the unit ships.

Window Assembly

FIGURE 1A
PRINTED LEGEND (WHITE WINDOW) CONFIGURATION

TWO WHITE DIFFUSERS, ONE CLEAR LEGEND

FIGURE 1B
PRINTED LEGEND (COLOR) CONFIGURATION

TWO WHITE DIFFUSERS, ONE COLOR DIFFUSER, ONE CLEAR LEGEND

FIGURE 2
CELL MEMBRANE TOUCHPAD CONFIGURATION

TWO DIVIDERS USED TO SUPPORT TOUCHPAD SUPPORT
MEMBRANE TOUCHPAD

FIGURE 3
ENGRAVED LEGEND CONFIGURATION

TWO WHITE DIFFUSERS, (ONE COLOR DIFFUSER, OPTIONAL)
ENGRAVED LEGEND

THIS VIEW SHOWN WITH ALL PARTS FOR ANY CONFIGURATION.

SEE NOTE 1

SEE NOTE 1

SEE NOTE 1

SEE NOTE 2 AND FIGURE 1A, 1B & 3 USED WITH WINDOWS

SEE NOTE 2 AND FIGURE 2 USED WITH TOUCHPAD

ASSEMBLY PART IDENTIFICATION

INDEX/PART NUMBER	DESCRIPTION
8	1085-252 DISPLAY (LED) PCB
9	1085-394 HOUSING, FRONT MODULE
10	1085-400 DIVIDER, CELL WINDOW
11	1085-396 DIFFUSER, WINDOW INSERT
12	1085-397 LEGEND, WINDOW INSERT
13	1085-398 WINDOW, MOLDED
14	1085-399 WINDOW FRAME
16	1085-389 PLATE, MEMBRANE SWITCH INSERT

NOTES:

1. DIVIDER QUANTITY AND LOCATION IS DEPENDANT ON CELL ALARM CONFIGURATION.
2. SEE FIGURES 1, 2, AND 3 FOR WINDOW CONFIGURATIONS.

FIG 1A: THESE THREE ITEMS ARE USED TOGETHER FOR THE PRINTED LEGEND WITH WHITE WINDOWS
 FIG 1B: THESE FOUR ITEMS ARE USED TOGETHER FOR THE PRINTED LEGEND FOR COLORED WINDOWS
 FIG 2: THIS ITEM IS USED WITH A CELL MEMBRANE TOUCHPAD OPTION.
 FIG 3: THIS ITEM IS USED FOR THE ENGRAVED LEGEND OPTION.

APPENDIX E

TELEPHONE / FAX NUMBER LIST

This errata sheet provides an easy-to-use reference for all major departments. Use these numbers for ordering equipment, application assistance, technical support, and scheduling field service

Please Note: Your instruction manual may contain other phone and fax numbers; this list will take precedence.

MAIN OFFICE

AMETEK Power Instruments – Rochester

255 North Union St., Rochester, NY 14605

DEPARTMENT/PRODUCT LINE	TELEPHONE	FAX
MAIN PHONE	585-263-7700	585-262-4777
FIELD SERVICE	800-374-4835	585-238-4945
REPAIRS/RETURNS	888-222-6282	585-238-4945
SALES SUPPORT	800-950-5503	585-454-7805

FAR EAST OFFICE

AMETEK Power Instruments
271 Bukit Timah Road, #03-09
Balmoral Plaza, Singapore 259708
Tel: 65-732-8675
Fax: 65-732-8676

UK OFFICE

AMETEK Power Instruments
Unit 20, Ridgeway
Donibristle Industrial Estate
Dunfermline, UK
Tel: 1383-825630
Fax: 1383-825715

PROCEDURES FOR FACTORY REPAIR AND RETURN

- B. Obtain a Returned material Authorization (RMA) number by calling AMETEK Repair Sales and giving the following information:

Model and Serial Number of the equipment
Failure Symptom – Be Specific
Approximate date of installation
The site name and address of the failed equipment
Complete shipping information for the return of the equipment if other than the operating site

Name and telephone number of person to contact if questions arise.

Enclose the information with the equipment and pack in a commercially accepted shipping container with sufficient packing material to insure that no shipping damage will occur. Mark the outside of the container with the RMA number.

Ship to the appropriate location

Attention: Repair Department
AMETEK Power Instruments
255 North Union Street
Rochester, New York 14605 USA
Tel: (888) 222-6282
Fax: (585) 238-4945

Your emergency equipment will be tested, repaired and inspected at the factory. Factory turnaround is ten working days or less (excluding shipping time).

For emergency service or repair status information, please contact the AMETEK Repair Sales Engineer at (800) 374-4835.

WARRANTY

AMETEK warrants equipment of its own manufacture to be free from defects in material and workmanship, under normal conditions of use and service. AMETEK will replace any component found to be defective, upon its return, transportation charges prepaid, within one year of its original purchase. AMETEK will extend the same warranty protection on accessories that is extended to AMETEK by the original manufacturer. AMETEK assumes no responsibility, expressed or implied, beyond its obligation to replace any component involved. Such warranty is in lieu of all other warranties expressed or implied.