

LPA-2

50/100W LINEAR POWER AMPLIFIER



System Manual
CA44-VER07

AMETEK[®]
POWER INSTRUMENTS

AMETEK Power Instruments
4050 N.W. 121st Avenue
Coral Springs, FL 33065
1-800-785-7274
+1-954-344-9822
www.ametekpower.com

March 2023

LPA-2

System Manual

Table of Contents

Ordering Information	1
Product Description	2
Applications	3
Installation	4
Test Equipment	5
Adjustment	6
Maintenance	7

ESD Warning!

YOU MUST BE PROPERLY GROUNDED, TO PREVENT DAMAGE FROM STATIC ELECTRICITY, BEFORE HANDLING ANY AND ALL MODULES OR EQUIPMENT FROM AMETEK.

*All semiconductor components can be **damaged** by the discharge of static electricity. Be sure to observe all Electrostatic Discharge (ESD) precautions when handling modules or individual components.*



IMPORTANT

We recommend that you become acquainted with the information in this manual before energizing your power amplifier. Failure to do so may result in injury to personnel or damage to the equipment, and may affect the equipment warranty. If you mount the carrier unit in a cabinet, it must be bolted to the floor or otherwise secured before you swing out the equipment, to prevent the installation from tipping over.

You should not remove or insert printed circuit modules while the power amplifier is energized. Failure to observe this precaution can result in undesired tripping output and can cause component damage.

AMETEK does not assume liability arising out of the application or use of any product or circuit described herein. AMETEK reserves the right to make changes to any products herein to improve reliability, function or design. Specifications and information herein are subject to change without notice. All possible contingencies which may arise during installation, operation, or maintenance, and all details and variations of this equipment do not purport to be covered by these instructions. If you desire further information regarding a particular installation, operation, or maintenance of equipment, please contact your local AMETEK representative.

Copyright © AMETEK

ALL RIGHTS RESERVED

AMETEK does not convey any license under its patent rights nor the rights of others.

Preface

Scope

This manual describes the functions and features of the LPA-2. It is intended primarily for use by engineers and technicians involved in the specification, application, operation, and maintenance of the LPA-2.

Equipment Identification

The equipment is identified by the Catalog Number on the front of the chassis.

Warranty

Our standard warranty extends for 5 years after shipment. For all repaired modules or advance replacements, the standard warranty is 1 year or the remaining warranty time, whichever is longer. Damage clearly caused by improper application, repair, or handling of the equipment will void the warranty.

Equipment Return & Repair Procedure

To return equipment for repair or replacement:

1. Call your AMETEK representative at **1-800-785-7274 (or 954-344-9822)** or e-mail at **repair.pulsar@ametek.com**.
2. Request an **RMA number** for proper authorization and credit.
3. Carefully pack the equipment you are returning.

Repair work is done most effectively at the factory. When returning any equipment, pack it in the original shipping containers if possible. Be sure to use anti-static material when packing the equipment. Any damage due to improperly packed items will be charged to the customer, even when under warranty.

AMETEK also makes available interchangeable parts to customers who are equipped to do repair work. When ordering parts (components, modules, etc.), always give the complete AMETEK part number(s).

4. Make sure you include your return address and the RMA number on the package.
5. Ship the package(s) to:

**AMETEK Power Instruments
Pulsar Products
4050 NW 121st Avenue
Coral Springs, FL USA 33065**

Table of Contents

Topic	Page No.
Chapter 1. Ordering Information	
Ordering Information	1-1
Chapter 2. Product Description	
2.1 General Description	2-1
2.2 Standard Nomenclature	2-1
2.3 50 W / 100 W LPA-2 Chassis	2-1
2.3.1 Front Panel Tour	2-3
2.3.2 Rear Panel Tour	2-3
2.4 50 W / 100 W Options	2-4
2.5 50 W / 100 W Configurations	2-4
2.5.1 50 W Configuration	2-4
2.5.2 100 W Configuration	2-4
2.6 Specifications	2-4
2.7 Environmental Requirements	2-7
2.8 Power Requirements and Dimensions	2-9
Chapter 3. Applications	
3.1 50 W / 100 W Applications	3-1
3.1.1 Directional Comparison Blocking Systems	3-1
3.1.2 Phase Comparison Blocking	3-2
3.1.3 Systems Using FSK	3-2
Chapter 4. Installation	
4.1 Installing Your New LPA-2	4-1
4.1.1 Unpacking & Inspecting	4-1
4.1.2 Mounting	4-1
4.1.3 Connecting to the Rear Panel	4-2
Chapter 5. Test Equipment	
Test Equipment	5-1
Chapter 6. Adjustment	
6.1 General Adjustment Information	6-1
6.2 50 W Adjustment Procedure	6-2
6.3 100 W Adjustment Procedure	6-4
6.3.1 100 W Adjustment (as shipped from factory)	6-4
6.3.2 100 W Custom Adjustment	6-5
Chapter 7. Maintenance / Troubleshooting	
7.1 Periodic Checks	7-1
7.2 Troubleshooting Sequence	7-1

Chapter 1. Ordering Information

Ordering Information

The 50 W LPA-2/100 W LPA-2 equipment identification number (catalog number) is located on the front of the chassis. The catalog number comprises nine (9) characters, each in a specific position. This number tells you whether the LPA-2 is a standalone 50 W chassis or one of the two chassis for a 100 W unit.

The table below provides a complete listing of the options for ordering a 50 W or 100 W unit, as well as a sample catalog number. To order a 50 W LPA-2 or 100 W LPA-2 assembly, simply identify the output power, DC voltage supply and options you want for each assembly. For example, the typical catalog number shown —L P A 2 1 0 0 1 B — orders a complete 100 W unit with a 125/250 Vdc power supply and a built-in skewed hybrid, comprised of two chassis.

Table 1–1. LPA–2 Catalog Numbers.

		1	2	3	4	5	6	7	8	9
	Typical Catalog Number	L	P	A	2	1	0	0	1	B
Basic Unit	Linear Power Amplifier	LPA-2								
Output Power	50 Watts					050				
	100 Watts					100				
DC Supply Voltage	48 Vdc					4				
	125/250 Vdc					1				
Options	None ¹					N				
	Skewed Hybrid ¹					S				
	100 W Combiner ²					C				
	Both 100 W Combiner & Skewed Hybrid ²					B				

¹ Only applies to 50W units (LPA2050xx).

² Only used for 100W units (LPA2100xx).

In addition to the catalog number, identifying a complete 50 W LPA-2/100 W LPA-2 assembly, a listing of spare parts is provided below.

Table 1-2. 50 W / 100W LPA-2 Spare Parts.

Part Type	Description	Part Number
Module	Option Board with 100 W Combiner & Skewed Hybrid	CA20-PA5A2-001
Module	Option Board – Skewed Hybrid Only	CA20-PA5A2-002
Module	Option Board – 100 W Combiner Only	CA20-PA5A2-003
Dummy Load	50 Ω , 100 W Short-Term Load	CA20-PA5A3-001
Coax Cable	1.5 ft. Long BNC–BNC	01W1-COAX2-111
Coax Cable	5 ft. Long BNC–BNC	01W1-COAX5-111
Coax Cable	12 ft. Long BNC–BNC	01W1-COAXA-111
Terminal Block	5-Position Plug-In Type	01NR-FXP05-340
Fuse (F1)	Fast-Blow 3 A, 3AG Type for 125 / 250 Vac	01RM-FEM31-000
Fuse (F1)	Fast-Blow 10 A, 3AG Type for 48 / 60 Vdc	01RM-FIM31-000
Coax T	Y-Connector (1 Male BNC to 2 Female BNC)	01NC-BNCY1-000

Chapter 2. Product Description

2.1 General Description

The AMETEK Linear Power Amplifier (LPA-2) comes in two versions:

- 1) The 50 W LPA-2 (a single chassis with a 50 W output)
- 2) The 100 W LPA-2 (two 50 W chassis combined for a 100 W output)

Both are class AB amplifiers that put out their rated power of 50 and 100 W continuously over a frequency range of 30–535 kHz. Both units are designed for inserting between an existing power-line carrier unit and the line tuner (LMU) to boost the normal power output of the carrier system.

The LPA-2 has the following important features.

- Automatic overload protection on its signal input and output.
- Self monitoring alarm.
- Built-in 50 Ω short-term 100 W load for testing.
- Optional built-in skewed hybrid.

Functional block diagrams and board layouts for the Main Amplifier, Overload Protection/Alarming and DC Power Supply are at the end of this chapter.

2.2 Standard Nomenclature

The standard nomenclature for AMETEK's linear power amplifier equipment is as follows:

Cabinet – contains fixed-racks, swing-racks, or open racks

Rack – contains one or more chassis

Chassis – contains several printed circuit boards, called modules (e.g., Power Supply or Power Amplifier)

Module – contains a number of functional circuits

Circuit – a complete function on a printed circuit board

2.3 50 W / 100 W LPA-2 Chassis

All individual chassis have the following standard dimensions:

Height – 3.50" (88.9 mm), requiring 2 rack units

Width – 19.00" (482.6 mm)

Depth – 14.63" (371.6 mm)

Each chassis has standard mounting holes for installation in a standard relay rack. And the chassis can be mounted either flush or projected by moving the mounting brackets to alternate side-plate positions.

Front Panel

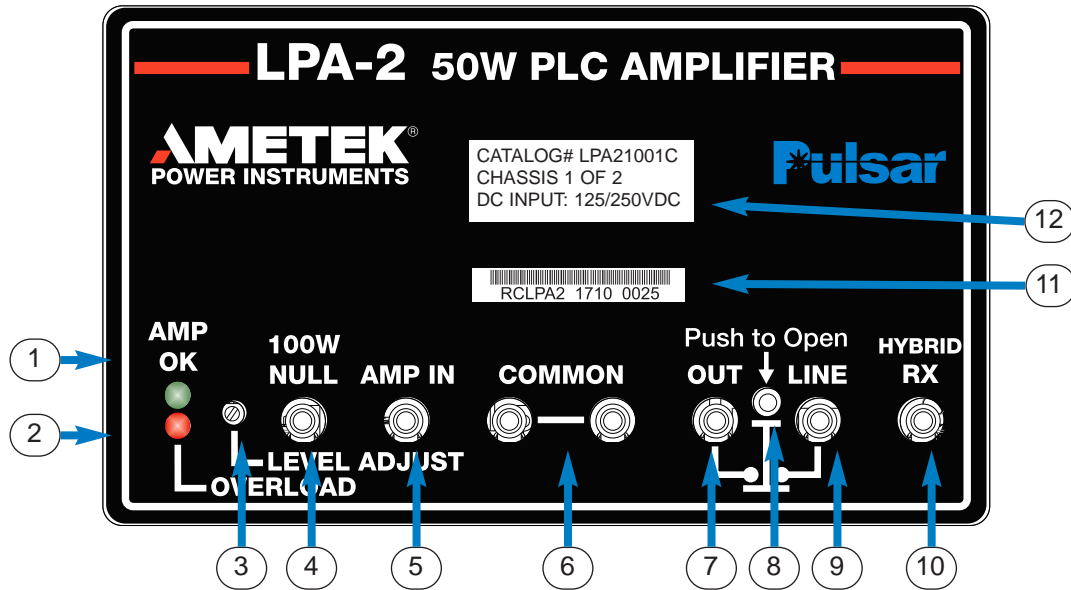

Figure 2-1a. Front View.

Rear Panel

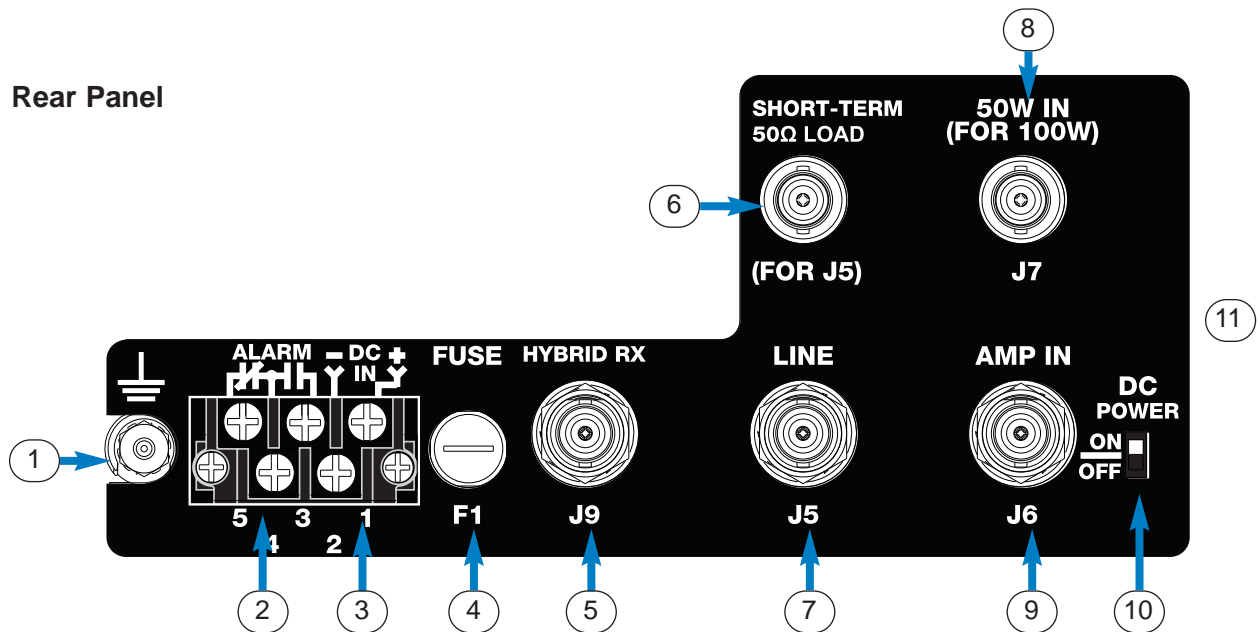

Figure 2-1b. Rear View.

2.3.1 Front Panel Tour

The LPA-2 front panel has a user-friendly power level adjustment, LEDs, & test points. The function of each item is detailed below (displayed left to right in Fig. 2-1a).

1. “AMP OK” Green LED – Self-monitoring hardware LED. When illuminated, it indicates that the unit’s power supply and amplifier are both working. Compares output power against input power to confirm amplification when signal is applied. When this LED turns off the LPA-2 alarm relay de-energizes and the alarming contact changes state.
2. “OVERLOAD” Red LED – Flashes on/off when too much input signal is applied, the load impedance is too far from 50 Ω, or any other condition that would cause overheating.
3. “LEVEL ADJUST” Pot – Adjusts input level drive to correct level for 50 W output. Clockwise rotation increases level.
4. “100W NULL” Test Point – Connected across optional 100W combiner balance resistor. Only used when combining two 50W units to balance a 100W output. When the signal level is nulled, on this test point, the units are set for optimum performance with low power loss in the combiner.
5. “AMP IN” Test Point – Amplifier input signal coming from driving Transmitter.
6. “COMMON” Test Points (2 available) – The common for all other front panel test points.
7. “OUT” Test Point – The output of the amplifier.
8. “Push to Open” Pushbutton Switch – In series with the output of the amplifier before going to the line. Allows an in-line meter to be inserted between the amplifier OUTPUT and the LINE test points for measuring forward or reflected power.
9. “LINE” Test Point – The final output of the amplifier going to the LINE coax connector on the back.

10. “HYBRID RX” Test Point – When ordered with the skewed hybrid option this allows measuring the signal level, at hybrid RX port, going to the Receiver.
11. Serial # Label – Barcoded. Center 4 digits, separated by spaces, are YYWW (YY= 2 digit year, WW= 2 digit week).
12. Catalog # Label – Shows the 9-digit catalog #, Chassis ID (when part of a 100 W unit), and DC voltage input.

2.3.2 Rear Panel Tour

The LPA-2 rear panel has connections, a fuse, and an on/off switch. The function of each item is detailed below (left to right, top to bottom Fig. 2-1b).

1. Ground Stud (#6-32) – Chassis ground. Connect with a # 10 gauge or larger wire directly to the ground bar in the panel/rack.
2. “ALARM” On 5-Position Terminal Block – Self-monitoring alarm normally closed contact (terminals 4 & 5) or normally open contact (terminals 4 & 3) available. This alarm relay is energized when the LPA-2 is working and will de-energize if there is an alarm condition or a power failure.
3. “DC IN” On 5-Position Terminal Block – Polarity sensitive dc power input (terminal 1 is positive & 2 is negative).
4. “FUSE (F1)” – For dc power input. Removable with a screwdriver if blown.

DC Volt Input	48 V	125/250 V
F1 Value	Fast-Blow 10 A	Fast-Blow 3 A

5. “HYBRID RX (J9)” – When ordered with the skewed hybrid option, this connects to the Receiver, otherwise unused.
6. “SHORT-TERM 50 Ω LOAD” – This is a 50Ω dummy load resistor temporarily connected, with an external coax cable, to the LINE (J5) connector *only* during the adjustment/checking, of the transmit signal level.

7. “LINE” (J5) – Connects amplifier output to the line tuner (LMU).
8. “50W IN (J7) – Only used for 100 W units when combining the 50 W output from another chassis with this unit to get 100 W total power.
9. “AMP IN (J6)” – Connects amplifier input to a driving carrier unit.
10. “DC POWER” On/Off Slide Switch – Turns dc power on and off. Recessed to prevent accidental powering up or down. Power off with a small screwdriver before disconnecting any wires.
11. Voltage/Chassis ID Label – located on the heat sink perpendicular to the rear panel. Indicates Catalog #, Chassis ID (1 or 2 of 2) & DC Input.

2.4 50 W / 100 W Options

As shown in Chapter 1 (Ordering Information), a built-in skewed hybrid is available for the LPA-2. Also, the correct DC input voltage must be chosen.

2.5 50 W / 100 W Configurations

The AMETEK Linear Power Amplifier (LPA-2) comes in two configurations:

- 1) The 50 W LPA-2 (one chassis with a 50 W output)
- 2) The 100 W LPA-2 (two chassis with a combined 100 W output)

2.5.1 50 W Configuration

The 50 W LPA-2 comprises one chassis assembly, coax cables and an optional skewed hybrid.

2.5.2 100 W Configuration

The 100 W LPA-2 comprises two chassis assemblies with coax cables as follows:

- Chassis #1 (1 of 2) – Master unit that is a basic 50 W amplifier plus a 100 W combiner module and an optional skewed hybrid.
- Chassis #2 (2 of 2) – Slave unit that is just a basic 50 W amplifier.

2.6 Specifications

The LPA-2 meets or exceeds all applicable ANSI/IEEE standards. Table 2-1a/b shows the technical specifications for the 50 W version. The technical specifications for the 100 W LPA-2 are shown in Table 2-2a/b.

Table 2–1a. 50 W LPA-2 Technical Specifications.

Frequency Bandwidth	30 kHz–535 kHz
Frequency Response	+/- 1 dB from 30–535 kHz
Input Impedance	Settable 50 Ω (normal setting) or 5 kΩ
Output Impedance	50 Ω
Maximum RF Power Input	10 W (+40 dBm or 22.4 V, 50 Ω reference)
Recommended RF Power Input	5 W (+37 dBm or 15.8 V, 50 Ω reference)
Minimum RF Power Input (to get 50 W output)	2 W (+33 dBm or 10V, 50 Ω reference)
Maximum Power Output	50 W continuous single frequency into 50 Ω load (+47 dBm, 50 Ω reference)
Harmonic & Spurious Noise Output	50 dB below 50 W fundamental
Alarm Relay Contact Rating	15 ms max operate time, 1 A max make/carry, 0.25 A max interrupt at 250 Vdc
50Ω Dummy Load (Testing & Setup)	100 W for 2 Minutes, 50 W for 3 minutes ²
Standard Compliance	Meets specifications: IEEE C93.5 ¹ & C37.90.1

¹ Unless otherwise shown in the specification tables.

² Dummy load self-protection thermal switch opens and prevents overheating & resets in 10 minutes typically after activation.

Table 2–1b. Optional Skewed Hybrid Specifications.

Specification	Value
Frequency Range	30–535 kHz
Max Power TX Input	100 W
TX Port Impedance (Internal)	50 Ω
RX Port Impedance (J9)	50 Ω or High Z (Open)
Output Port Impedance (J5)	50 Ω
Insertion Loss: TX Port to Output*	0.5 dB Max
Insertion Loss: Output to RX Port * (J5–J9)	14.5 dB Max
Transhybrid Loss: Isolation Between TX & RX*	40 dB Min

* With Exact Impedance Matching on Output

Table 2-2a. 100 W LPA-2 Technical Specifications.

Frequency Bandwidth	30 kHz–535 kHz
Frequency Response	+/- 1 dB from 30–535 kHz
Input Impedance	Settable to 50 Ω or 5 k Ω. (Normally one 50 W chassis is set to 50 Ω and the other to 5 k Ω.)
Output Impedance	50 Ω
Maximum RF Power Input	10 W (+40 dBm or 22.4 V, 50 Ω reference)
Recommended RF Power Input	5 W (+37 dBm or 15.8 V, 50 Ω reference)
Minimum RF Power Input (to get 100W output)	2 W (+33 dBm or 10V, 50 Ω reference)
Maximum Power Output	100 W continuous single frequency into 50 Ω load (+50 dBm, 50 Ω reference)
Harmonic & Spurious Noise Output	50 dB below 100 W
Maximum Overall Power Loss for Failure of one 50 W Power Amplifier:	-3.5 dB
Alarm Relay Contact Rating	15 ms max operate time, 1 A max make/carry, 0.25 A max interrupt at 250 Vdc
50Ω Dummy Load (Testing & Setup)	100 W for 2 Minutes, 50 W for 3 minutes ²
Standard Compliance	Meets relevant specifications: IEEE C93.5 ¹ & C37.90.1

¹ Unless otherwise shown in the specification tables.

² Dummy load self-protection thermal switch opens and prevents overheating & resets in 10 minutes typically after activation.

Table 2-2b. Optional Skewed Hybrid Specifications.

Specification	Value
Frequency Range	30–535 kHz
Max Power TX Input	100 W
TX Port Impedance (Internal)	50 Ω
RX Port Impedance (J9)	50 Ω or High Z (Open)
Output Port Impedance (J5)	50 Ω
Insertion Loss: TX Port to Output*	0.5 dB Max
Insertion Loss: Output to RX Port * (J5–J9)	14.5 dB Max
Transhybrid Loss: Isolation Between TX & RX*	40 dB Min

* With Exact Impedance Matching on Output

2.7 Environmental Requirements

This section provides three tables depicting the 50 W LPA-2/100 W LPA-2 environmental requirement specifications, broken down as follows:

- Environmental Requirements (table below)
- Altitude Dielectric Strength De-Rating for Air Insulation (Table 2–4)
- Altitude Correction For Maximum Temperature Of Cooling Air (ANSI C93.5) (Table 2–5)

Table 2–3. Environmental Requirements.

Ambient Temperature Range	-20 to + 60°C (derated per Table 2-5) of air-contacting equipment
Relative Humidity	Up to 95% (non-condensing) at 40°C (for 96 hours cumulative)
Altitude	Up to 1,500 m (without derating) Up to 6,000 m (using Table 2-4 and Table 2-5)
Transient Withstand Capability	All external user interfaces meet SWC specifications of ANSI C37.90.1 (1989) & IEEE 1613
1-Minute Hi-Pot Withstand	DC input to alarm contact and to ground: 3,000 Vdc, derated per Table 2-4.

Table 2-4.
Altitude Dielectric Strength
De-Rating for Air Insulation.

Altitude (Meters)	Correction Factor
1,500	1.00
1,800	0.97
2,100	0.94
2,400	0.91
2,700	0.87
3,000	0.83
3,600	0.79
4,200	0.74
4,800	0.69
5,400	0.64
6,000	0.59

Table 2-5.
Altitude Correction for Max
Temp Of Cooling Air (IEEE C93.5).

Altitude (Meters)		Temperatures (Degrees C)		
		Short-Time	Long-Time	Difference From Usual
Usual	1,500	55	40	—
Unusual	2,000	53	38	2
Unusual	3,000	48	33	7
Unusual	4,000	43	28	12

2.8 Power Requirements and Dimensions

The power requirement specifications for the 50 W LPA-2 are shown in Table 2–6.

Table 2–7 shows the power requirement specifications for the 100 W LPA-2.

The weight and dimensions for the 50 W LPA-2 & 100 W LPA-2 are shown in Table 2–8.

Table 2–6.
50 W LPA-2 Power Requirement Specifications.

50 W LPA-2		Max Supply Power (Watts) at Nominal Voltage		
Nominal Battery Voltage	Permissible Voltage Range	Standby	5 W Transmit	50 W Transmit
48/60 Vdc	38–76 Vdc	28.8 W	48 W	168 W
110/125/250 Vdc	88–300 Vdc	31.2 W	77.5 W	200 W

Table 2–7.
100 W LPA-2 Power Requirement Specifications.

100 W LPA-2		Max Supply Power (Watts) at Nominal Voltage		
Nominal Battery Voltage	Permissible Voltage Range	Standby	10 W Transmit	100 W Transmit
48/60 Vdc	38–76 Vdc	57.6 W	96 W	336 W
110/125/250 Vdc	88–300 Vdc	62.5 W	155 W	400 W

Table 2–8. LPA-2 Weight & Dimension Specifications.

Equipment	Net Weight		Height		Width		Depth		Rack Space
	lbs	Kg	inches	mm	inches	mm	inches	mm	
50 W LPA-2	12	5.4	3.5	88.9	19.00	482.6	14.63	371.6	3 RU
100 W LPA-2	24	10.9	7.0	177.8	19.00	482.6	14.63	371.6	6 RU

Figure 2-2. Main Amp & Option Board Block Diagram.

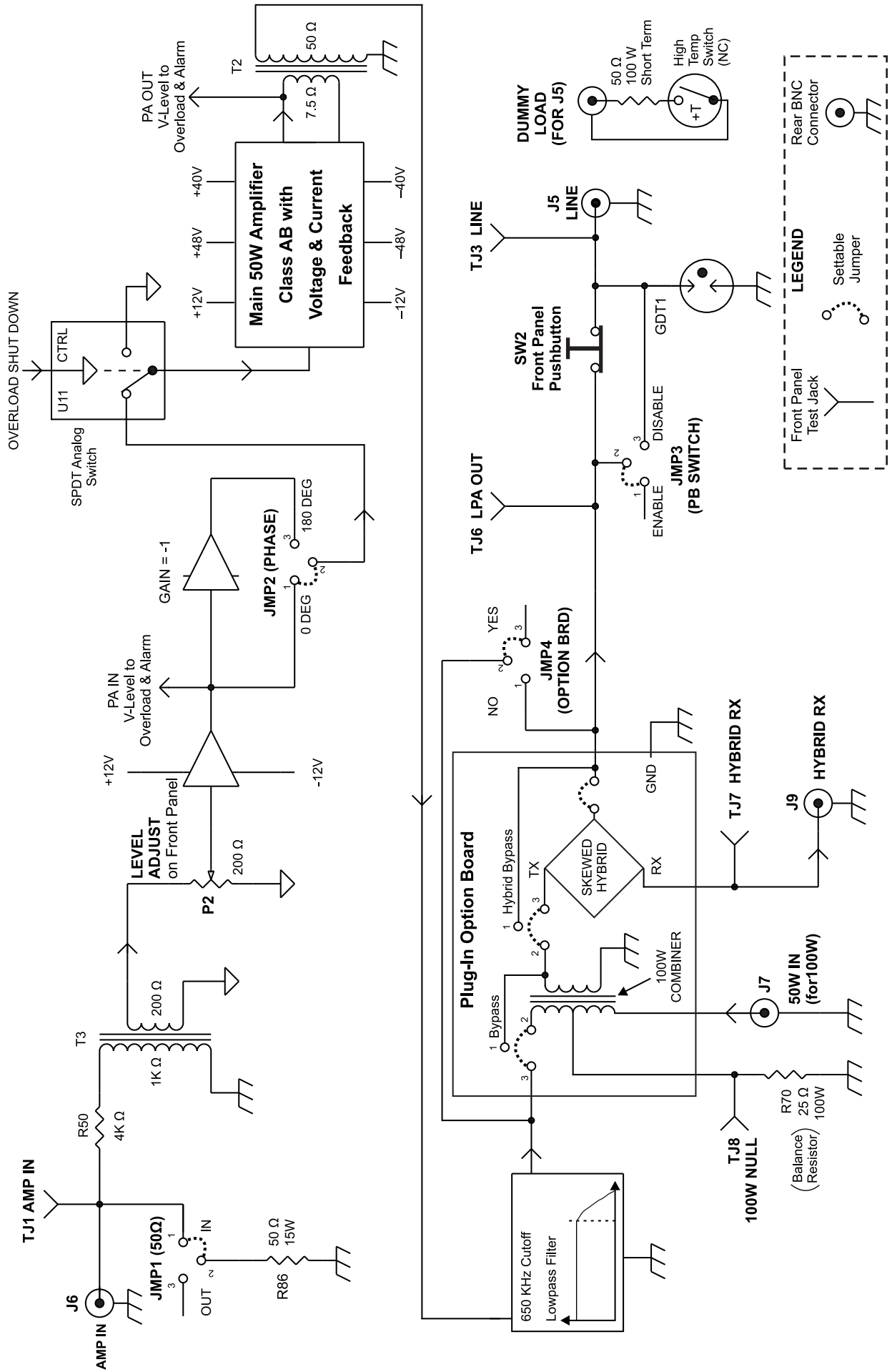

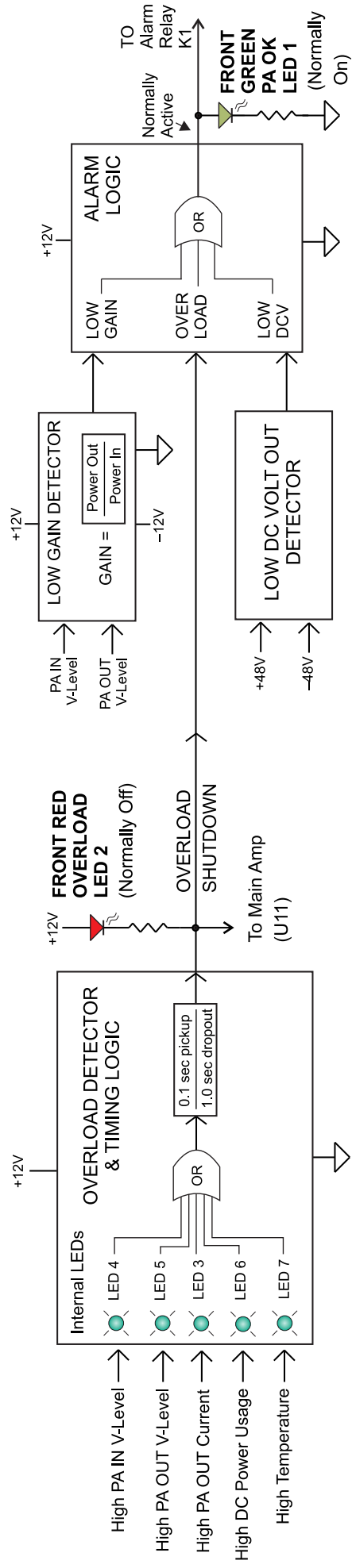
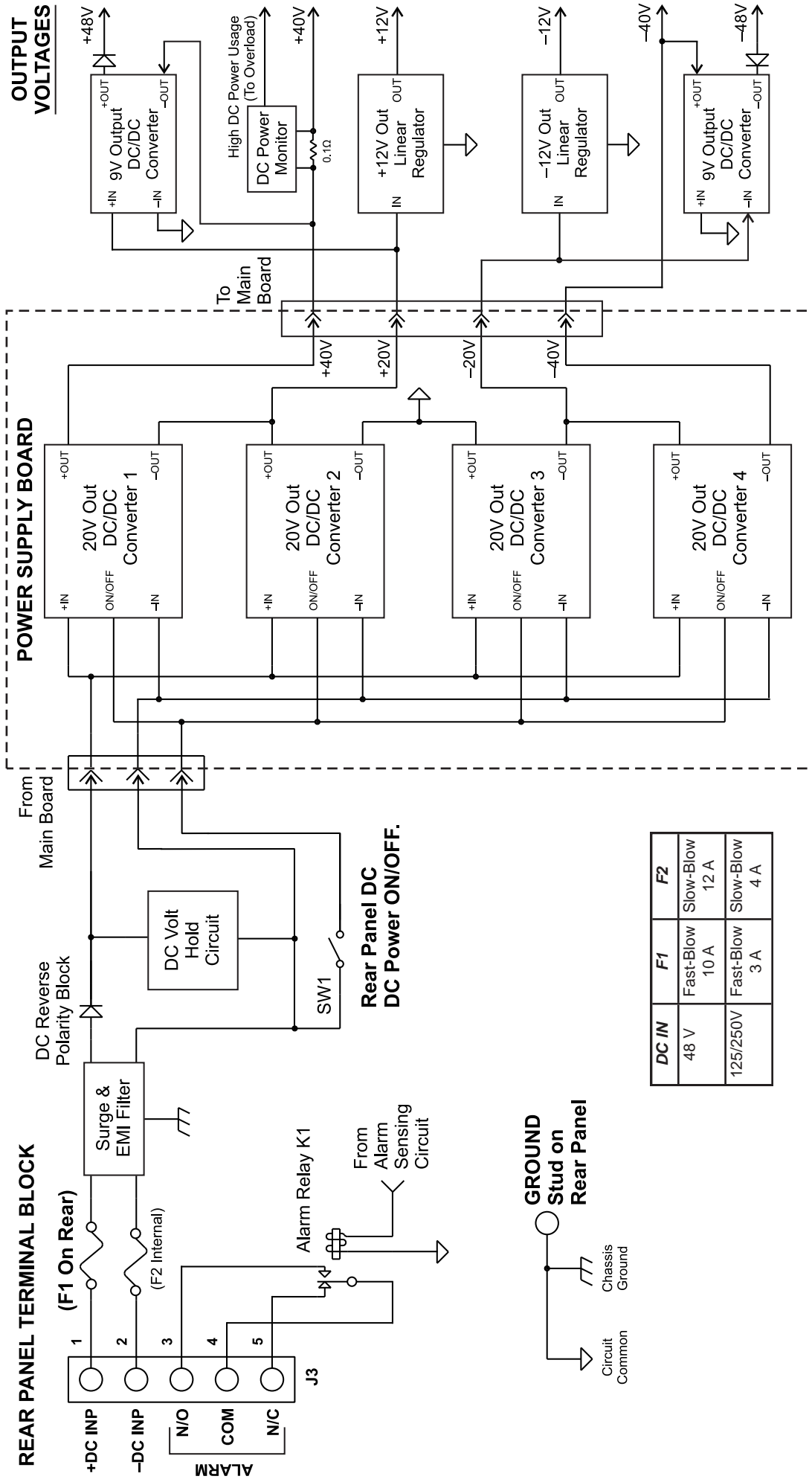
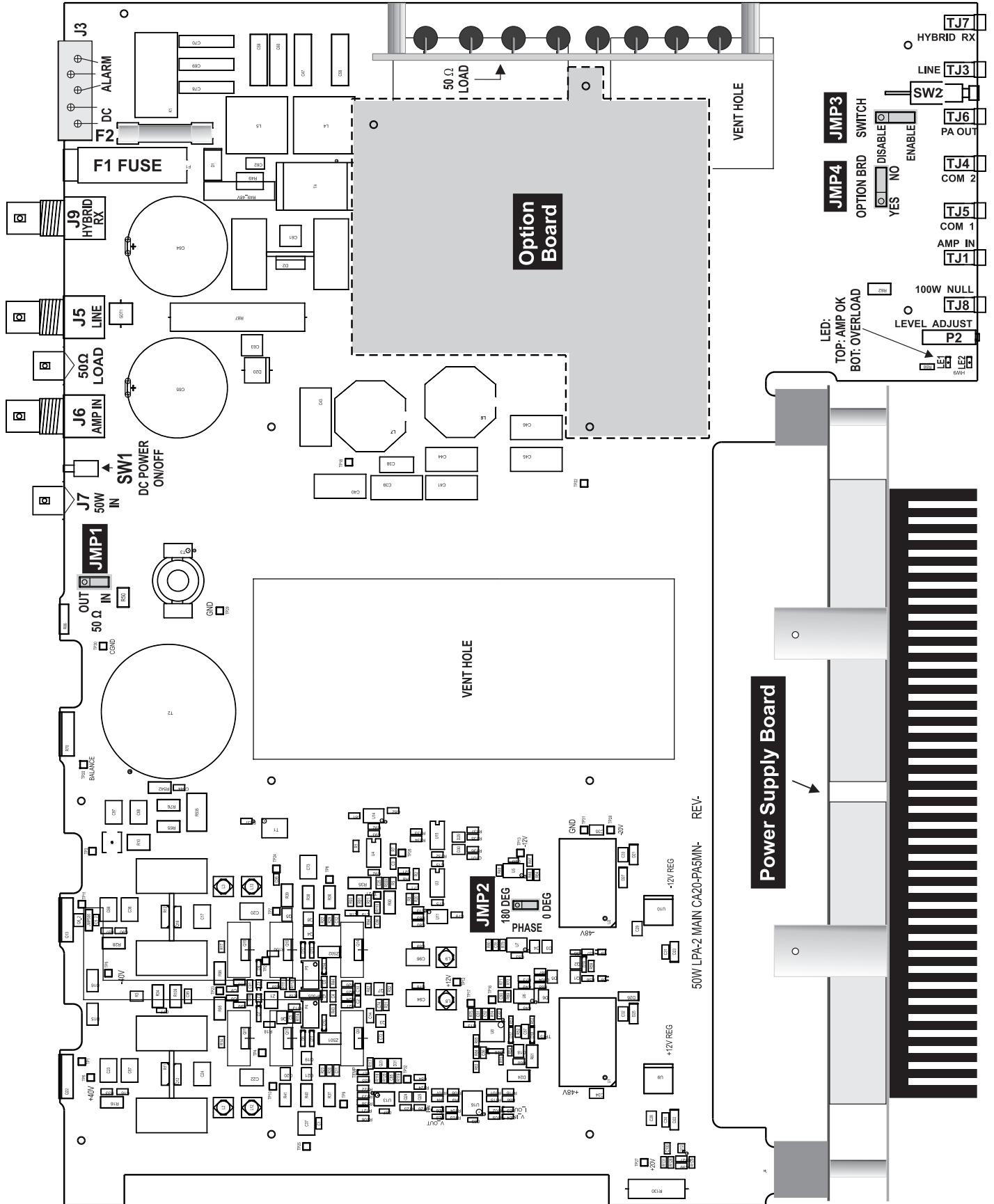

Figure 2-3. Overload Protection & Alarming Block Diagram.

Figure 2-4. DC Power Supply Block Diagram.





2

Figure 2-5. LPA-2 Main Board.

Table 2-9. Jumper Functions.

Board	Jumper	Function
Main	JMP1	Controls input impedance of LPA-2 (Total input impedance should normally be 50 Ω to load the driving carrier unit properly).
	JMP2	Controls phase shift of the LPA-2 (Normally set to 0°, except for a double chassis 100 W LPA-2 which requires one of the two units to be set to 0° & the other to 180° for the 100 W combiner to work properly).
	JMP3	Enables or disables the front panel pushbutton switch capability for allowing insertion of an in-line power meter for testing.
	JMP4	Allows bypassing the option board when not installed.
Option	JMP1 (Table 2-11)	Bypasses or inserts 100 W combiner & skewed hybrid options individually.
	JMP2	Enables or disables 50 Ω termination on RX port of skewed hybrid.

Table 2-10. Jumper Default Shipped Settings.

Board	Jumper	Name	50 W Single Chassis	100 W Double Chassis	
				Chassis 1 (with Option Board)	Chassis 2 (w/o Option Board)
Main	JMP1	50 Ω Input Resistor	IN	IN	OUT
	JMP2	Phase Shift	0°	180°	0°
	JMP3	PB Switch for Test Points	Enabled	Enabled	Enabled
	JMP4	Option Board Installed	NO for no Options YES for Skewed Hybrid	YES	NO
Option	JMP1 (Table 3-3)	Skewed Hybrid & 100 W Combiner Options	Skewed Hybrid IN (when ordered)	100 W Combiner Always IN , Skewed Hybrid IN or OUT (Depending on Order)	Not Applicable
	JMP2	Skewed Hybrid RX Port Termination	TERMINATE	TERMINATE	Not Applicable

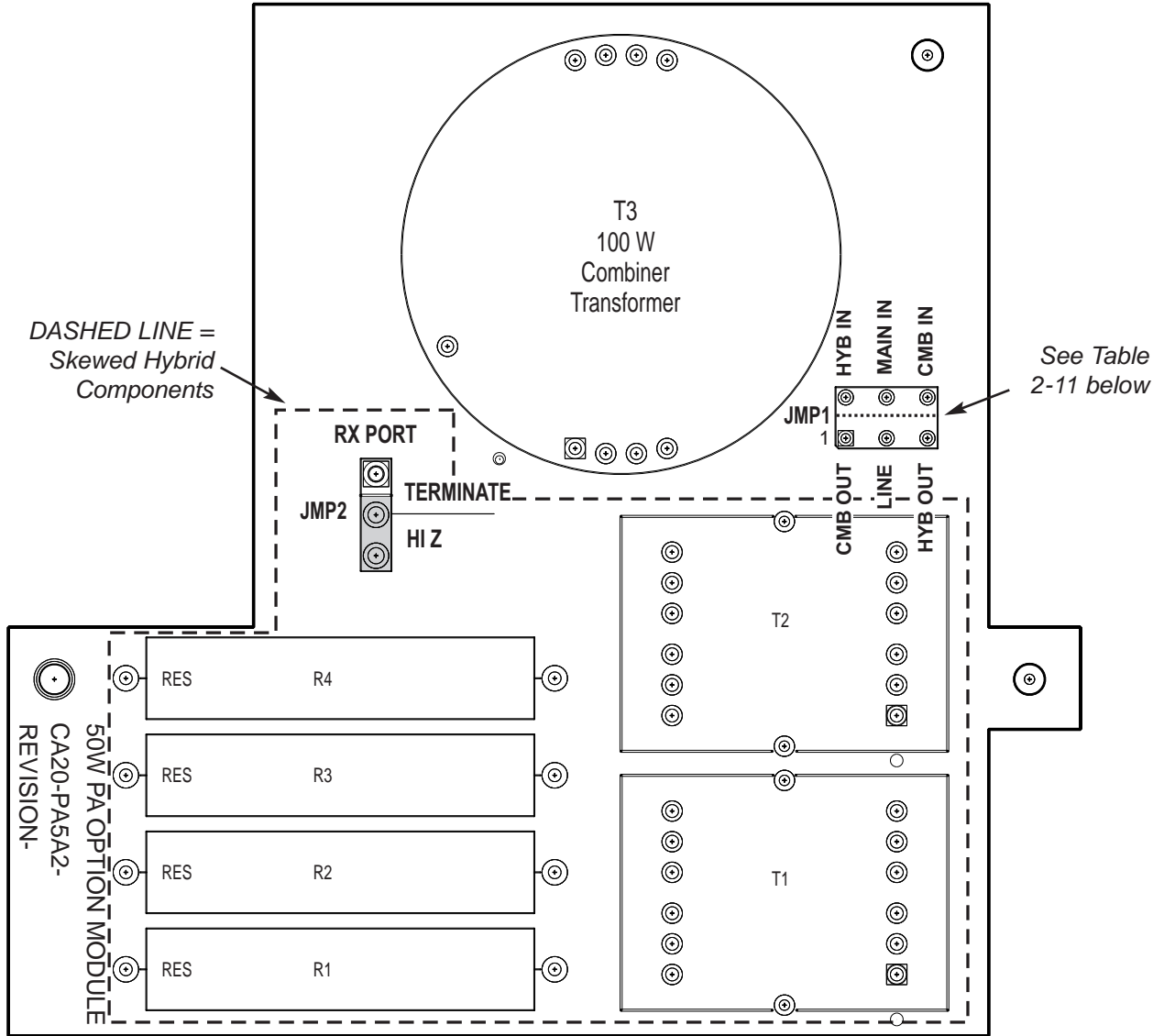

Figure 2–6. Option Board.

Table 2–11. Part Numbers / JMP1 Setting(s).

Option Ordered	100 W Combiner Only	Skewed Hybrid Only	Both 100 W Combiner & Skewed Hybrid
Part Number	CA20-PA5A2-003	CA20-PA5A2-002	CA20-PA5A2-001
JMP1 Setting	<p>HYB IN Main IN CMB IN</p> <p>CMB OUT Line HYB OUT</p>	<p>HYB IN Main IN CMB IN</p> <p>CMB OUT Line HYB OUT</p>	<p>HYB IN Main IN CMB IN</p> <p>CMB OUT Line HYB OUT</p>

USER NOTES

Chapter 3. Applications

3.1 50 W / 100 W Applications

The 50 W LPA-2 and 100 W LPA-2 are used in applications where the losses between the transmitting and receiving carrier units are greater than a 10W system can handle. Usually this is due to high loss on the power line because of a long line, underground cable, a combination of underground cable and overhead lines, or a line with untrapped taps on it.

We recommend that before applying a high power linear power amplifier (LPA-2), you do a thorough analysis of the expected power line loss, including all tuners, hybrids, coupling capacitors, etc. You can often decrease total loss in a system by properly tuning the line, using the optimum hybrids for the application, removing any unnecessary attenuators in carrier receiver sets, and selecting the proper carrier frequency. Using the lowest possible carrier frequency (generally 30-50 kHz) is especially important on underground cables, as their loss significantly increases at the higher frequencies.

When applying high power LPA-2s, you must treat the following three types of systems differently:

- Directional Comparison Blocking systems
- Phase Comparison Blocking systems
- Systems using Frequency Shift (FSK)

3.1.1 Directional Comparison Blocking Systems

For Directional Comparison Blocking systems, where the receiver can hear its own transmitter without any problems, you do not need to connect hybrids between the output of the LPA-2 and the local receiver if the receiver is designed to handle higher power. UPLC/UPLC-II™ and TC-10B can handle up to 100 W input. The receiver of these units can be bridged directly to the output of the LPA-2. See Figure 3-1. You can only bridge the carrier receiver across the output of the 100 W LPA-2 if it is capable of sustaining 70.7 Vrms, 50Ω reference or 86.6 Vrms 75Ω reference across its input without saturating. When using with a ON-OFF DCB unit, you must set it up for 4-wire operation (separate transmit and receive paths).

NOTE:
For TC-10B units, you must set the receiver sensitivity jumper to NORM. This means that on the RF Interface Module you would set JU1 and JU5 in the OUT position to give 4-wire operation and JU6 to NORM to give 13 dB of attenuation to the incoming local transmit signal. This is not needed on UPLC/UPLC-II™ units.

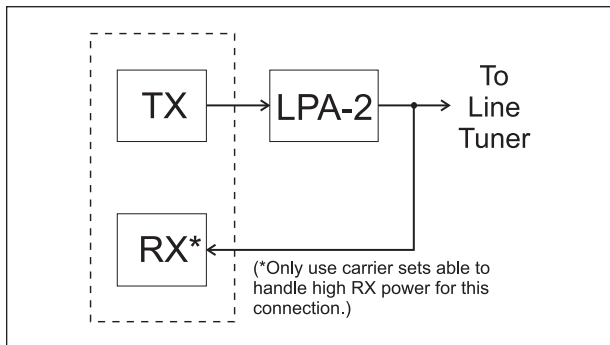

Figure 3-1. ON-OFF DCB Unit with LPA-2 RF Connections.

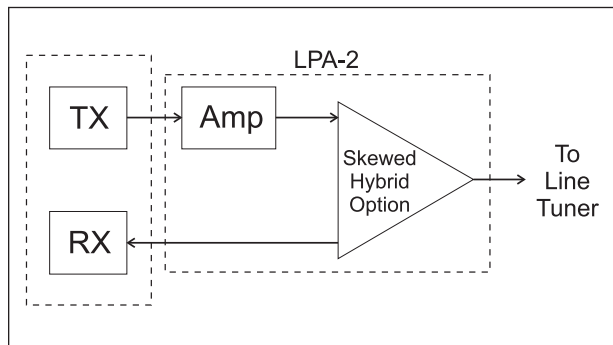

Figure 3-2. Phase Comp. Blocking or FSK Sets with LPA-2 RF Connections.

3.1.2 Phase Comparison Blocking

For Phase Comparison Blocking Systems that have an older type analog receiver, a skewed hybrid must be used on the output of the LPA-2 to prevent the local receiver from being over-driven in addition to being set for 4-wire operation. See Figure 3-2.

NOTE:

The TC-10B that has an old analog receiver can be identified as it will have 2 separate modules (a Receiver & Level Detector) instead of the wider Universal Receiver module.

3.1.3 Systems Using FSK

For systems using frequency shift carrier units, a Skewed Hybrid option must also be used between the output of the LPA-2 and the input of the receiver, to prevent interference. The FSK unit must be set for 4-wire operation, with separate TX & RX coax connectors used. See Figure 3-2.

Chapter 4. Installation

4.1 Installing Your New LPA-2

Installing your LPA-2 is a three-step process:

1. Unpack and Inspect chassis
2. Mount the chassis
3. Connect your equipment and the dc power source to the rear of the chassis

4.1.1 Unpacking & Inspecting

The LPA-2 is shipped with each chassis in its own box. Special inserts are used to protect the equipment from damage.

Whether you plan to install the unit immediately or place it into storage, you should unpack the box(es) and check to make sure all parts are present and undamaged.



CAUTION

UNPACK EACH PIECE OF EQUIPMENT CAREFULLY SO THAT NO PARTS ARE LOST. INSPECT THE CONDITION OF THE LPA-2 AS YOU REMOVE IT FROM ITS CARTON(S). YOU MUST REPORT ANY DAMAGED EQUIPMENT TO THE CARRIER. DAMAGES ARE THE RESPONSIBILITY OF THE CARRIER, AND ALL DAMAGE CLAIMS ARE MADE GOOD BY THE CARRIER. PLEASE SEND A COPY OF ANY CLAIM TO AMETEK.

Each chassis has an identifying label on the front panel and rear heat sink. The label tells you whether the chassis is a 50 W LPA-2 or one of the two chassis for a 100 W LPA-2. If it is a 100 W LPA-2, the label also tells you whether it is chassis 1 (of 2) or chassis 2 (of 2). The label also includes the serial number.

Storage

If you are setting the equipment aside before use, be sure to store it in its special cartons (in a moisture-free area) away from dust and other foreign matter.

Installation Location

Install your LPA-2 in an area which is free from:

- Temperature exceeding specified environmental limits
- Corrosive fumes
- Dust

4.1.2 Mounting

The LPA-2 arrives already assembled. It is ready to mount directly out of the carton. Coaxial cables (and input T-connector for 100 W unit only) are included.

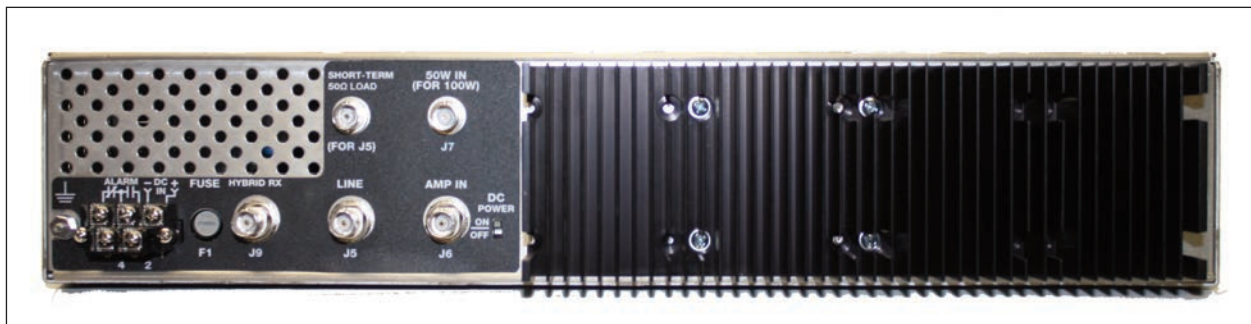

Figure 4-1. Rear View.

You can mount your LPA-2 in any of the following configurations:

- In a fixed-rack cabinet.
- In a swing-rack cabinet
- In an open rack.

⚠ CAUTION

IF YOU ARE MOUNTING YOUR LPA-2 IN A SWING-RACK CABINET, MAKE SURE THAT THE CABINET IS FIRMLY FASTENED BEFORE OPENING THE RACK (TO PREVENT TIPPING).

Or mount it in your own, customer-specified configuration.

To mount your chassis, refer to the following figures for chassis dimensions and mounting measurements.

Both the 50 W and 100 W chassis can be rack mounted and have standard-spaced mounting holes. Because of the heat produced by the LPA-2, and also to allow for better air circulation around the chassis, we recommend that you always mount them at the top of a rack or panel. If space isn't a problem it is best to leave one (1) rack unit (R.U.) of space, i.e., 1.75" (44.45 mm) directly beneath and above the chassis. For the 100 W LPA-2, you *must* leave 1 RU of space between its two chassis.

This is critical if running the unit at full power all the time. For example, in a POTT/DCUB system where Guard may be ran at full power instead of the normal 1/10 power level.

4.1.3 Connecting to the Rear Panel

The LPA-2 rear panel wiring connections are shown in diagrams at the end of this chapter.

You make all necessary connections to the rear. These include:

- Terminal Block Connections
- Coaxial Cables
- Ground Stud

All connections are made via the rear terminal block (TB1) and the coaxial connectors (J5–J9) per the connection diagram. The terminal block screws are metric M3 (approx. #4 screw) and can accept wire lugs with a max outer diameter of 0.32". Maximum tightening torque for terminal block screws is 10 in/lbs. For the DC input, #14 AWG wire is recommended with #20 AWG being sufficient for the alarm connections. Maximum current drain for 125Vdc is 1.6 A per chassis. A #10 AWG wire for the #6-32 ground stud is recommended, routed directly to the ground bar and kept as short as reasonable.

All PC board jumpers are factory set based on the catalog number. However, the top cover plate can be removed and jumpers can be changed if the application changes.

For example, if you ordered the LPA-2 as a 100 W unit and then decided to use it as two 50 W units or you no longer wanted to use the optional built-in hybrid, then jumpers will need to be changed. Details of jumpers are shown in the block diagrams and board layout drawings here in this chapter.



Figure 4-2. Rear View, Close Up.

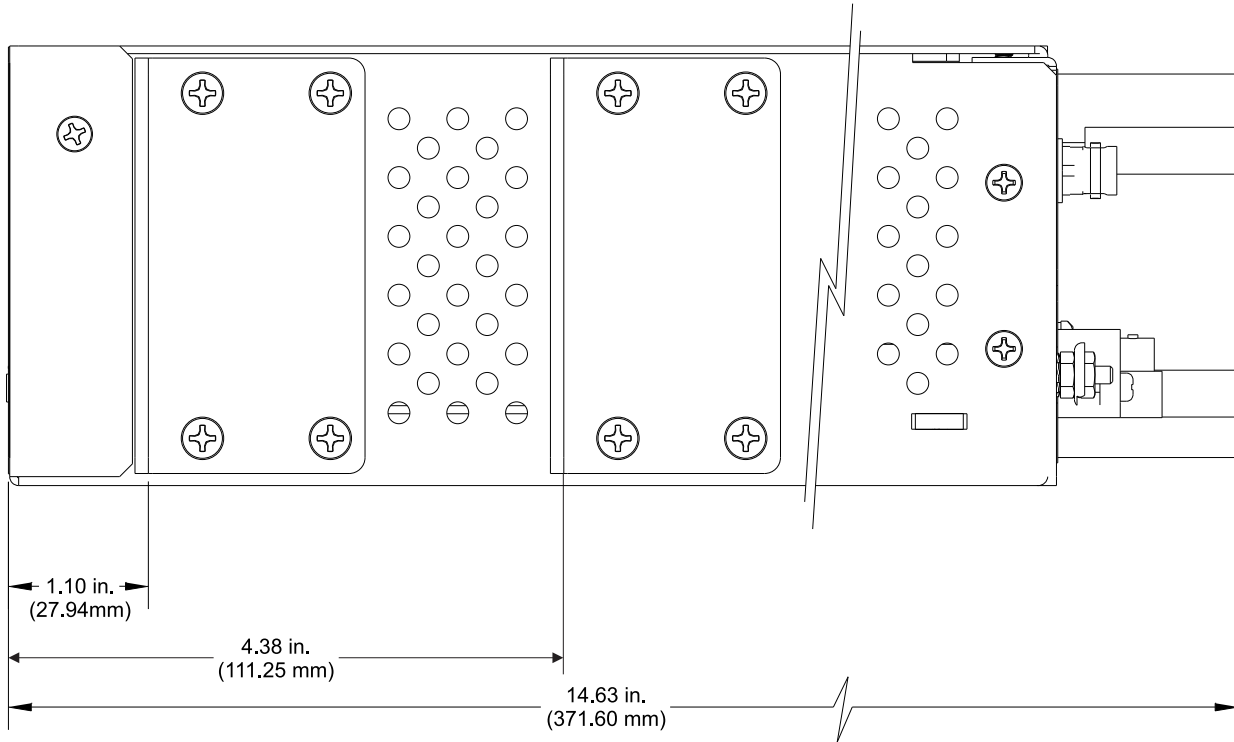

Figure 4–3a. Side View – Standard Projection Mounting Position.

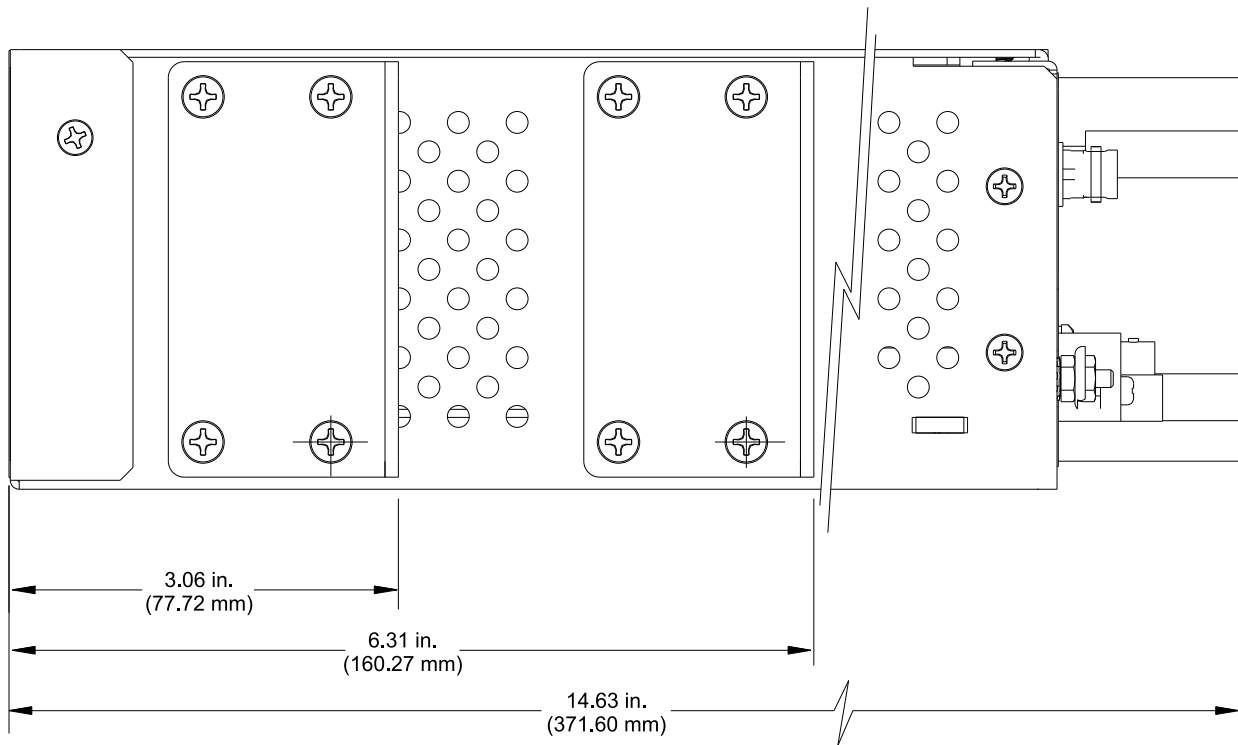
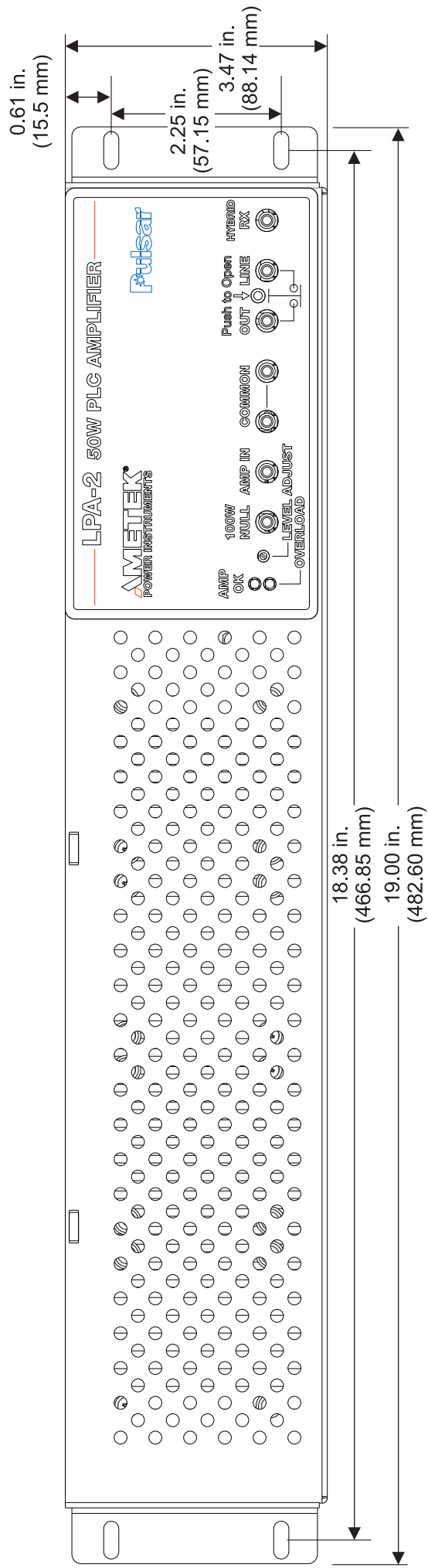

Figure 4–3b. Optional Projection Mounting Position (Reversed Mounting Ears).

Figure 4-4. LPA-2 Front Dimensions.



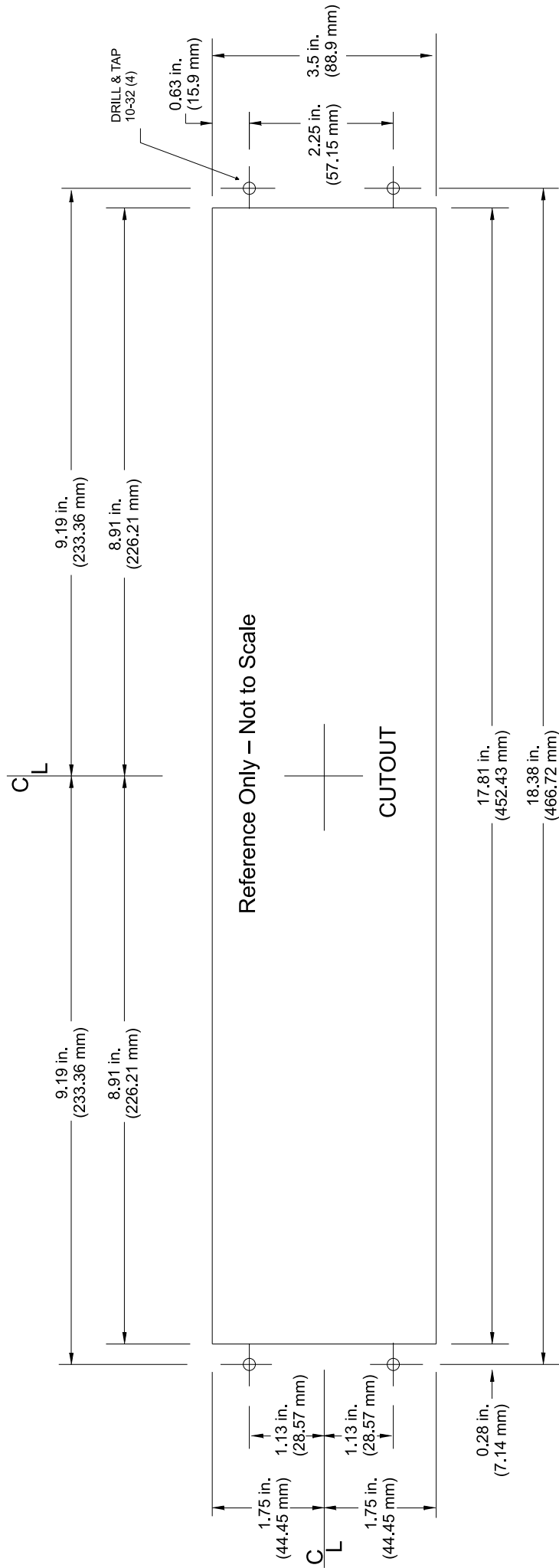
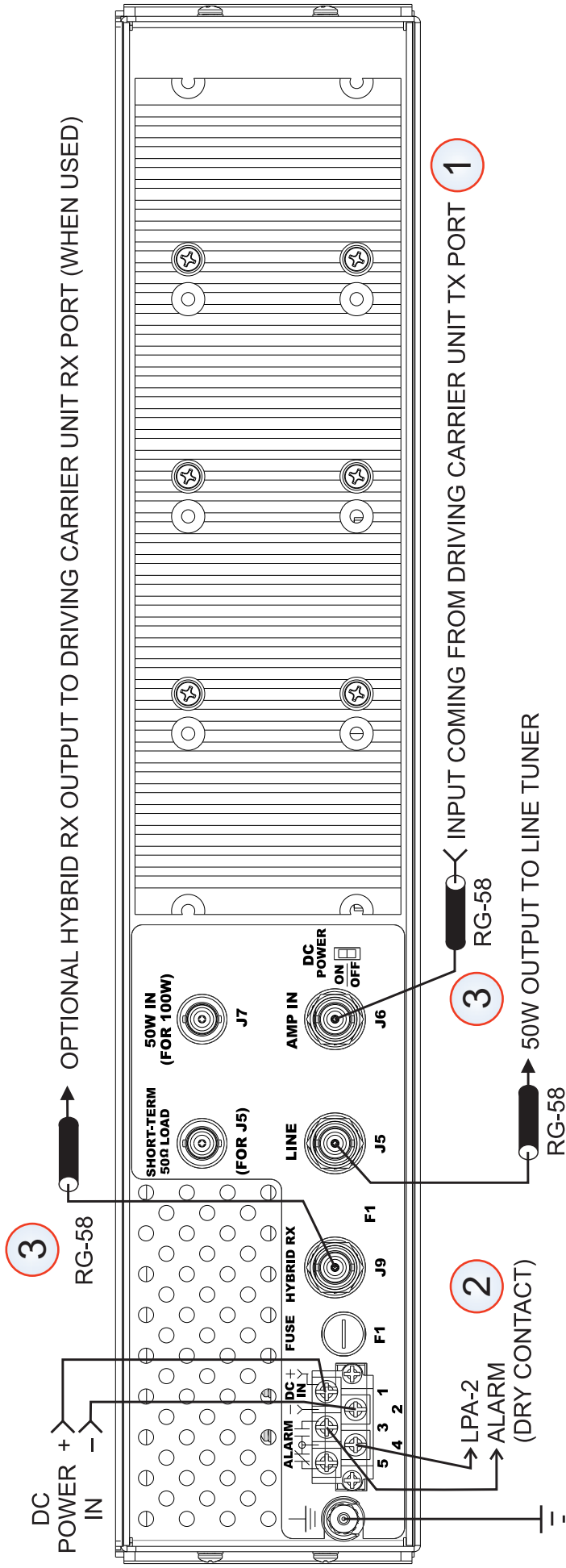

Figure 4-5. Panel Drilling Plan for 2RU 50 W LPA-2 Chassis.

Figure 4-6. 50 W LPA-2 Connection Diagram.



NOTES:

- 1) The driving carrier unit should be set for 4-wire operation with TX & RX ports separated on it.
- 2) Normally open alarm contact shown connected but normally closed available also.
- 3) Three 12' and one 1.5' coax cables supplied with unit for inside of panel only. The short coax cable is for connecting J5 temporarily to the short -term 50 Ω load for testing.

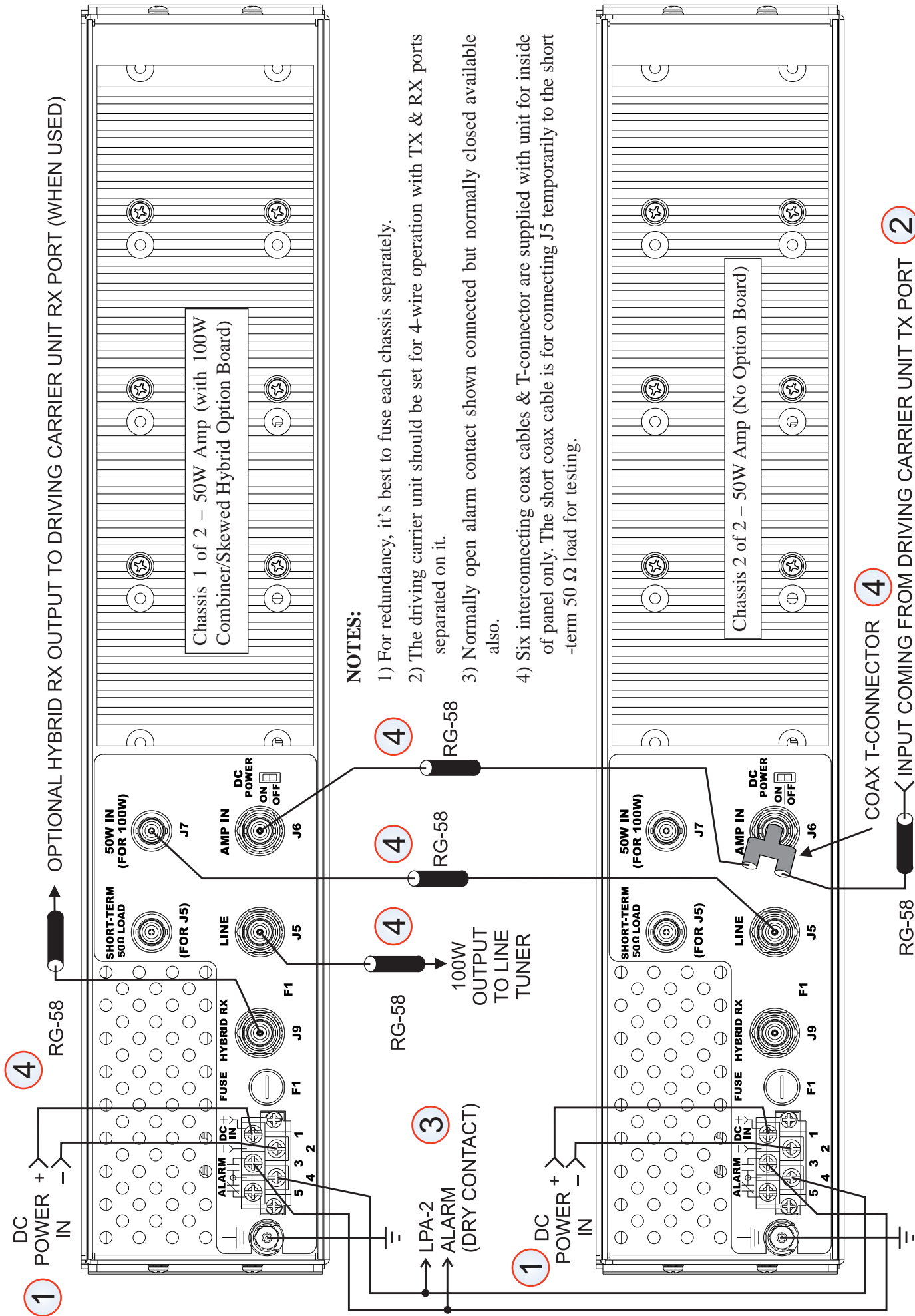

NOTES:

- 1) For redundancy, it's best to fuse each chassis separately.
- 2) The driving carrier unit should be set for 4-wire operation with TX & RX ports separated on it.
- 3) Normally open alarm contact shown connected but normally closed available also.
- 4) Six interconnecting coax cables & T-connector are supplied with unit for inside of panel only. The short coax cable is for connecting J5 temporarily to the short-term 50 Ω load for testing.

Figure 4-7. 100 W LPA-2 Connection Diagram.

Chapter 5. Test Equipment

Test Equipment

The same type of test equipment, used to test carrier units, is also used to test and adjust the 50 W LPA-2 and 100 W LPA-2. The following test equipment is recommended:

50 W / 100 W LPA-2 Recommended Test Equipment.

Equipment	Application
High-Impedance Frequency Selective Level Meter 1 kHz to 1 MHz <ul style="list-style-type: none">• PowerComm Solutions PCA-4125• Signal Crafters Model 110• Spectrum Analyzer*• Oscilloscope	<ul style="list-style-type: none">• Checking TX Level• Checking RX level on optional Skewed hybrid
Reflected Power Meter <ul style="list-style-type: none">• Signal Crafters Model 70• PowerComm Solutions PCA-4125	Adjusting Line Tuner to Match LPA-2 Output Impedance

* AMETEK can assist in providing an external device to measure up to 100 W.



CAUTION

WE RECOMMEND THAT THE USER OF THIS EQUIPMENT BECOME THOROUGHLY ACQUAINTED WITH THE INFORMATION IN THESE INSTRUCTIONS BEFORE ENERGIZING THE 50 W LPA-2/100 W LPA-2 AND ASSOCIATED ASSEMBLIES. YOU SHOULD NOT REMOVE OR INSERT PRINTED CIRCUIT MODULES WHILE THE UNIT IS ENERGIZED. ALL INTEGRATED CIRCUITS USED ON THE MODULES ARE SENSITIVE TO AND CAN BE DAMAGED BY THE DISCHARGE OF STATIC ELECTRICITY. YOU SHOULD ALWAYS OBSERVE ELECTROSTATIC DISCHARGE PRECAUTIONS WHEN HANDLING MODULES OR INDIVIDUAL COMPONENTS. FAILURE TO OBSERVE THESE PRECAUTIONS CAN RESULT IN COMPONENT DAMAGE.

Chapter 6. Adjustment

6.1 General Adjustment Information

All LPA-2s are shipped from the factory pre-adjusted for the recommended 5W (+37 dBm) input to drive them to full power output. So, if you are able to set your driving carrier unit to the 5W full power output, then no adjustment should be necessary on the LPA-2. However, the LPA-2 can be driven with any power level between 2 W (+33 dBm) to 10W (+40 dBm), but it will require readjustment for the different input power level to give the correct full power output. All power levels measurements should be taken with a 50 Ω reference impedance used on the meter.

Also, as-shipped jumper settings (Table 2–11) are based on how the LPA-2 was ordered and will work without any jumper setting changes if you are using the unit as ordered. If you want to make any special jumper settings, other than as-shipped

defaults, then remove the screws on the top cover to access the main board to change them. Refer to Figure 2–5 for location of jumpers and Table 2–9 for their function.

Following are step-by-step procedures to properly power on and verify/adjust the 50 W LPA-2 and 100 W LPA-2.

Simplified connection drawings are shown to aid in understanding where signal levels are being measured and how the system should be connected for testing. Also, refer to the front & rear panel drawings in Chapter 2 for front test point and rear connector locations.

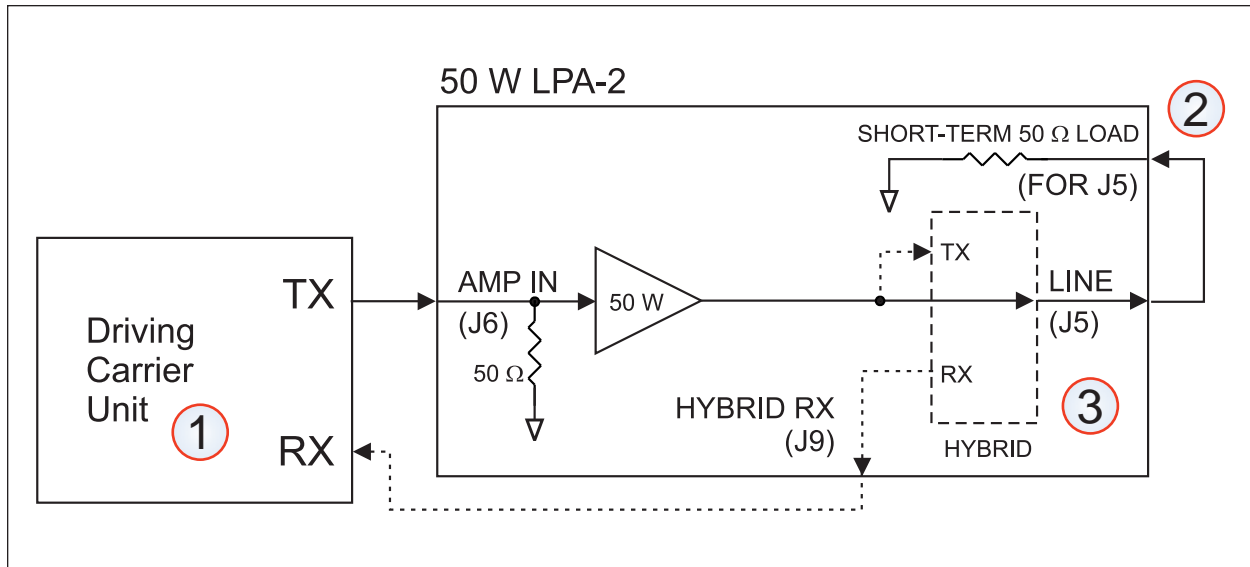

Figure 6-1. Simplified Connections – 50 W.

NOTES for Figure 6-1

- 1) The driving carrier unit must be set for 4-wire operation with TX & RX not connected together.
- 2) Connect to the short-term 50 Ω load for adjustment & testing only.
- 3) Optional Skewed Hybrid shown in dotted lines.

6.2 50 W Adjustment Procedure

1. Verify proper connections per the connection diagram, (Figure 6-1). Temporarily terminate the LINE (J5) output of the 50 W LPA-2 with the built-in 50 Ω high-wattage load by connecting it to the SHORT-TERM 50 Ω LOAD connector above it with a coax cable.

NOTE:
The 50 Ω load is located on the right side wall of the chassis (viewed from front). It will heat up but is protected from overheating by a thermal switch. The load can handle up to 80W continuously.

2. Make sure the LPA-2 is not powered up yet and use the LPA-2 input as a load for the driving carrier unit. With the driving carrier

unit's TX output connected to the AMP IN (J6) coax connector it will be terminated in a 50 Ω load located on the LPA-2's input that can handle up to 10W of power. Set the high-power TX output level of the driving carrier unit to 5W (+37 dBm) which will produce 50W (+47 dBm) at the output of the LPA-2. Set the low-power TX output level of the driving carrier unit to 0.5W (+27 dBm) which will produce 5W (+37 dBm) at the output of the LPA-2. (This is a typical level for the low-power TX of the driving carrier unit but it can be set for a higher level if desired.) Key the driving carrier unit to send low-power TX to the LPA-2 when initially powered up so that the LPA-2 can be verified at a low power setting first before going to full power.

3. Power on the LPA-2 by sliding up the recessed DC Power switch on the rear

panel with a small screwdriver. Verify that the green “AMP OK” LED illuminates. It should always stay lit when powered on as long as there is a 50 Ω load or properly adjusted line tuner connected to the LINE port (J5).

4. Verify the input level between the AMP IN / COMMON test points is equal to the low-power TX level of the driving carrier unit.
5. Verify the following levels in the order shown.

Driving Carrier Unit	LPA-2 Test Points	
	AMP IN / COM	LINE / COM
LL Key	0.5W / +27dBm	5W/+37dBm(15.8Vrms)
HL Key	5W / +37dBm	50W/+47dBm(50Vrms)

The full power (HL Key) output value should be within +/- 0.3 dB or +/- 1 V of the value shown above.

If this value needs to be adjusted, because you are using a different drive level than the recommended 0.5 W-LL / 5 W-HL, then turn the front LEVEL ADJUST potentiometer (pot) with a small screwdriver. Clockwise rotation of this pot increases output signal level. Also, if desired, a

power meter’s input can be inserted into the OUT/COMMON test points and the meter’s output inserted into the LINE / COMMON test points. Then the push-button switch can be pressed to insert the meter for enough time to measure the output power. The power meter should measure a forward power of 50W and show no or very low reflected power. (or VSWR close to 1).

6. Power off the LPA-2 and remove the coax connecting the 50 Ω load to the LINE J5 connector. Then instead connect the LINE J5 connector to the coax going out to line tuner (LMU) or into the system.
7. Power on the LPA-2 to verify the output power remains at approximately 50W and the reflected power is less than 15%. Very high reflected power can cause the LPA-2 to temporarily go into shut-down/overload mode to prevent damage until the reflected power comes down. The LPA-2 should not be readjusted at this point as the non-perfect 50 Ω load of the line tuner (LMU) will cause a difference in the power level. The greater the % reflected power, then the greater the difference in measured LPA-2 output power level.

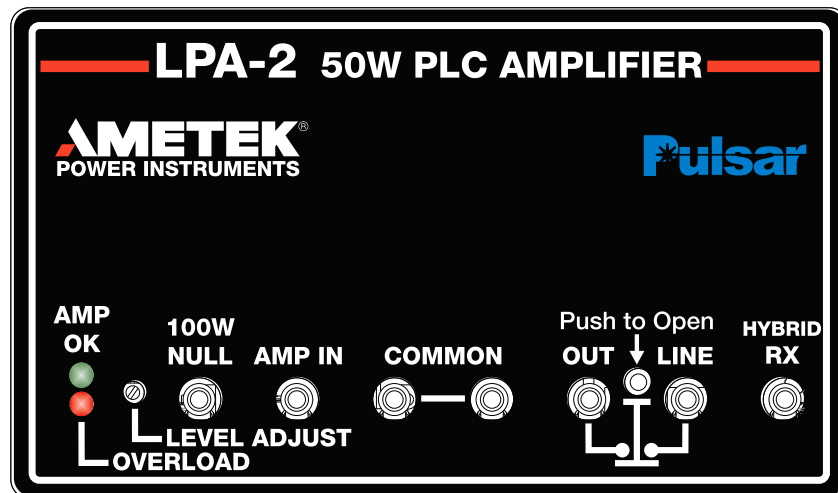

Figure 6–2. Front Overlay.

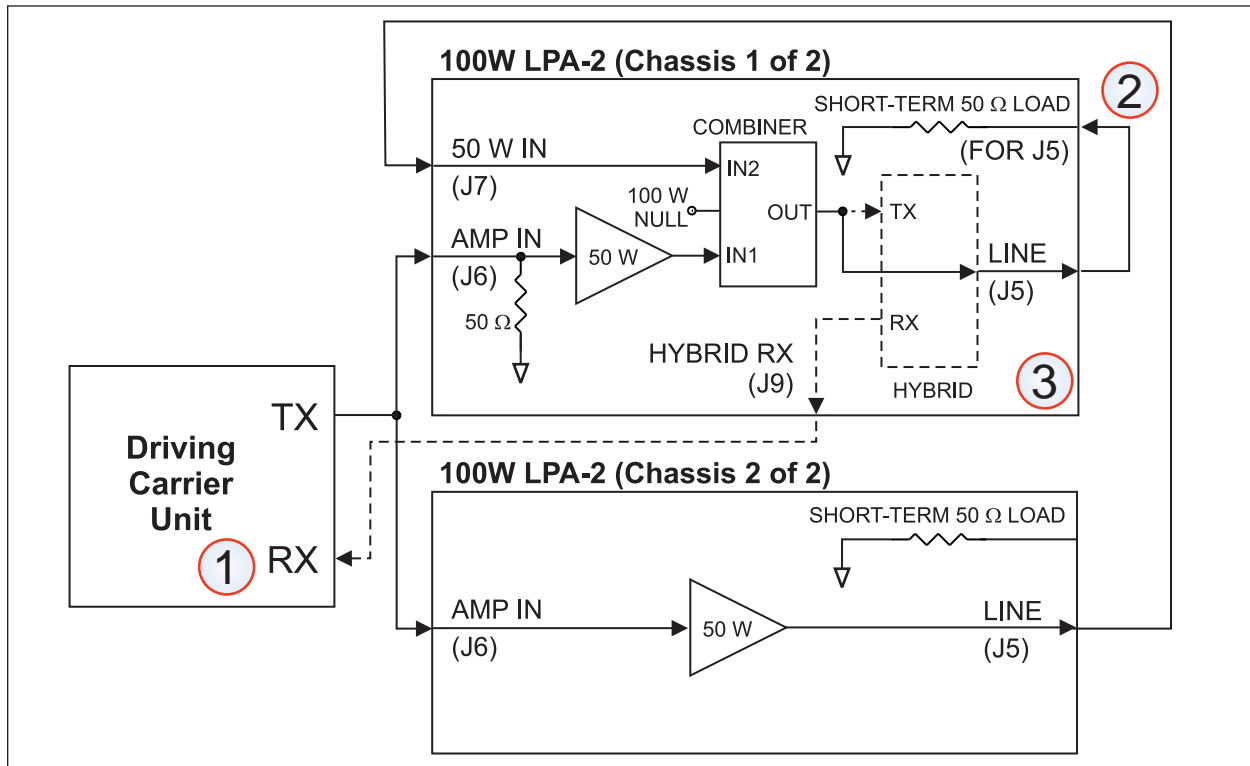

Figure 6-3. Simplified Connections – 100 W.

NOTES for Figure 6-3

- 1) The driving carrier unit must be set for 4-wire operation with TX & RX not connected together.
- 2) Connect to the short-term 50 Ω load for adjustment & testing only.
- 3) Optional Skewed Hybrid shown in dotted lines.

6.3 100 W Adjustment Procedure

Two types of adjustment procedures are given:

- With factory settings (as shipped)
- Custom (due to different desired input power level, changing out a failed part, or changing the application of how the amplifier will be used)

6.3.1 100 W Adjustment (as shipped from factory)

1. Verify proper connections per the connection diagram, (Figure 6-3). Temporarily terminate the LINE (J5) output of the 100W LPA-2 with the built-in 50 Ω high-wattage load in chassis 1 of 2 by connecting it to the SHORT-TERM 50 Ω LOAD connector above it with a coax cable.

NOTE:
The 50 Ω load is located on the right side wall of chassis (viewed from front). It will heat up but is protected from overheating by a thermal switch. The load can handle up to 80W continuously and 100W for up to 2 minutes before disconnecting automatically. If this happens you must wait 10 minutes before reusing the load.

2. Make sure both chassis of the LPA-2 are not powered up yet and use the LPA-2 input as a load for the driving carrier unit. With the driving carrier unit's TX output connected to the AMP IN (J6) coax connector, on both chassis's of the LPA-2, it will be terminated in a 50Ω load located on the LPA-2's input (chassis 1 of 2) that can handle up to 10W of power. Set the

high-power TX output level of the driving carrier unit to 5W (+37 dBm) which will produce 100W (+50 dBm) at the output of the LPA-2. Set the low-power TX output level of the driving carrier unit to 0.5W which will produce 10W at the output of the LPA-2. (This is a typical level for the low-power TX of the driving carrier unit but it can be set for a higher level if desired.) Key the driving carrier unit to send low-power TX to the LPA-2 when initially powered up so that the LPA-2 can be verified at a low power setting first before going to full power.

3. Power on both chassis of the LPA-2 by sliding up the recessed DC Power switch on the rear panel with a small screwdriver. Verify that the green “AMP OK” LED illuminates. It should always stay lit when powered on as long as there is a 50 Ω load or properly adjusted line tuner connected to the LINE port (J5).
4. Verify the input level between the AMP IN / COMMON test points is equal to the low-power TX level of the driving carrier unit.
5. Verify the following levels, in the order shown, on chassis 1 of 2 *only*. (*not on chassis 2 of 2*).

Driving Carrier Unit	LPA-2 Test Points (Chassis 1 of 2) (All measurements made on chassis 1 of 2)	
	AMP IN / COM	LINE / COM
LL Key	0.5W / +27dBm	10W / +40dBm (22.4 Vrms)
HL Key	5W / +37dBm	100W / +50dBm (70.7 Vrms)

The full power (HL Key) output value should be within +/- 0.3 dB or +/- 2 V of the value shown above.

Also, if desired, a power meter’s input can be inserted into the OUT / COMMON test points and the meter’s output inserted into the LINE / COMMON test points. Then the pushbutton switch can be pressed to insert the meter for enough time to measure the output power. The power meter should measure the forward power of 100W and

should show no or very low reflected power.

6. Power off the LPA-2 and remove the coax connecting the 50 Ω load to the LINE J5 connector. Then instead connect the LINE J5 connector to the coax going out to line tuner (LMU) or into the system.
7. Power on the LPA-2 to verify the output power remains at approximately 100W and the reflected power is less than 15%. Very high reflected power can cause the LPA-2 to go into shut-down/overload mode to prevent damage until the reflected power comes down. The greater the % reflected power, then the greater the difference in measured LPA-2 output power level.

6.3.2 100 W Custom Adjustment

1. Verify proper connections per the connection diagram, (Figure 6–3). Temporarily terminate the LINE (J5) output of the 100W LPA-2 with the built-in 50 Ω high-wattage load inside chassis 1 of 2 by connecting it to the SHORT-TERM 50 Ω LOAD connector above it with a coax cable.
2. Make sure both chassis of the LPA-2 are not powered up yet and use the LPA-2 input as a load for the driving carrier unit. With the driving carrier unit’s TX output connected to the AMP IN (J6) coax connector it will be terminated in a 50Ω load located on the LPA-2’s input (chassis 1 of 2) that can handle up to 10W of power. Set the high-power TX output level of the driving carrier unit to 5W (+37 dBm) which will produce 100W (+50dBm) at the output of the LPA-2. Set the low-power TX output level of the driving carrier unit to 0.5W which will produce 10W at the output of the LPA-2. (This is a typical level for the low-power TX of the driving carrier unit but it can be set for a higher level if desired.) Key the driving carrier unit to send high-power TX. Initial adjustment is best done at full power.

3. Turn the LEVEL ADJUST potentiometer (pot) all the way down on *both* chassis's (1 of 2 and 2 of 2). That is full counter-clockwise rotation for at least 20 full turns (zero gain setting).
4. Power on *both* chassis 1 & 2 by sliding up the recessed DC Power switch on the rear panels with a small screwdriver. Verify that the green "AMP OK" LED illuminates. It should always stay lit when powered on as long as there is a 50 Ω load or properly adjusted line tuner connected to the LINE port (J5).
5. Verify the input level between the AMP IN / COMMON test points is equal to the low-power TX level of the driving carrier unit.
6. **Make all measurements on chassis 1 of 2.** But adjust both of the two chassis LEVEL ADJUST pots starting with chassis 1 of 2 first. With the driving carrier unit keyed to high-level, first use the chassis 1 of 2 LEVEL ADJUST pot to set the output level between the LINE / COMMON test points as shown in the table below.

Next, use the chassis 2 of 2 LEVEL ADJUST pot to set the output level of chassis 2 of 2. Measuring between the 100W NULL / COMMON test points (*chassis 1 of 2*), set this level to a minimum (null). This step balances the 2nd 50W LPA-2 chassis' output level with the first so that they are both putting out 50W of

power. Finally measure the total output level between the LINE / COMMON test points of chassis 1 of 2 and verify it is at 100W ($\pm 0.3\text{dB}$ or $\pm 2\text{V}$). Then verify the LPA-2 puts out approximately 10W with its driving carrier unit keyed at low-level. This low-level is not very critical and does not have to be as accurate as the high-level.

7. Also, if desired, a power meter's input can be inserted into the OUT / COMMON test points and the meter's output inserted into the LINE / COMMON test points. Then the pushbutton switch can be pressed to insert the meter for enough time to measure the output power. The power meter can measure the forward power of 100W and should show no or very low reflected power. The greater the % reflected power, then the greater the difference in measured LPA-2 output power level.
8. Power off the LPA-2 and remove the coax connecting the 50 Ω load to the LINE J5 connector. Then instead connect the LINE J5 connector to the coax going out to line tuner (LMU) or into the system.
9. Power on the LPA-2 to verify the output power remains at approximately 100W and the reflected power is less than 15%. Very high reflected power can cause the LPA-2 to go into shut-down/overload mode to prevent damage until the reflected power comes down.

NOTE:
Chassis 1 of 2 level is $\frac{1}{4}$ (-6dB) of the normal level because only one chassis is outputting and half the power of one chassis is being lost in the "unbalanced" combiner. Once it is balanced with chassis 2 of 2 there will be no loss in the combiner.

Driving Carrier Unit	LPA-2	LPA-2 Chassis 1 of 2 Test Points (ALL measurements are made on chassis 1 of 2 only)		
		AMP IN / COM	100 W NULL / COM	LINE / COM
LL Key	Chassis 1 of 2	0.5 W / +27 dBm	-	2.5W / +34dBm (11.2 Vrms)
LL Key	Chassis 2 of 2	0.5 W / +27 dBm	Min., < +9 dBm (0.6 Vrms)	10W / +40dBm (22.4 Vrms)
HL Key	Chassis 1 or 2	5 W / +37 dBm	-	25W / +44dBm (35.4 Vrms)
HL Key	Chassis 2 of 2	5 W / +37 dBm	Min., < +20 dBm (2 Vrms)	100W / +50dBm (70.7 Vrms)

Chapter 7. Maintenance / Troubleshooting

7.1 Periodic Checks

If there are no alarms on the driving carrier unit or the LPA-2, then checks can be on whatever normal maintenance interval your company uses. The following values should be measured.

- Full Power TX Output (within 0.5 dB of last time measured value)
- TX Reflected Power % (or VSWR) – should be less than 15% (VSWR < 2.3), the lower the better performance.

We recommend that you keep a log book as a visible record of periodic checks and to note any gradual degradation in a unit's performance.

7.2 Troubleshooting Sequence

CASE #1: If the green AMP OK LED goes off and the red OVERLOAD LED illuminates, then the alarm relay will deenergize giving an alarm. Also, the LPA-2 may be pulsing on and off in the alarm state, which usually indicates a problem with the load on the LPA-2's LINE port. If this happens follow the steps below.

1. Power off the LPA-2 using the rear ON/OFF slide switch.
2. Remove the coax from the LINE (J5) port on the LPA-2 and connect it temporarily to the 50 Ω short-term load (for J5) with a coax cable. This removes any possibilities of an improper load causing a problem with the LPA-2.
3. Power on the LPA-2 using the rear ON/OFF slide switch, and see if the green LED illuminates and the red LED goes off. If not, then verify the signal level on the AMP IN test point is at the correct level (normally 5W input for LPA-2 full output).

If it is too high, then the driving carrier unit will need to be adjusted down in level.

4. Once the LPA-2 is proven to be working properly with the 50 Ω short-term load, then reconnect the system coax cable to the LPA-2 and if the problem still exists, troubleshooting will need to be done to verify the coax cable is good, the line tuner (LMU) is good/adjusted properly for less than 15% reflected power, and any other devices between the line tuner and output of the LPA-2 are good.
 5. Verify the reflected power is less than 15%
- CASE #2:** If no LEDs are illuminated.

1. Verify that the rear ON/OFF slide switch is in the ON position.
2. Verify that the proper dc voltage is applied in the correct polarity to the rear terminal block on terminals 1 (+) and 2 (-).
3. Power off the LPA-2 using the rear ON/OFF slide switch. Remove fuse F1 on the rear using a small screwdriver to twist the cap off. Then verify if the fuse is good.
4. If needing to replace fuse F1 and the fuse blows again, this usually indicates that there is a failure due to either the Power Supply in the LPA-2 partially failing or the main amplifier itself failing.
5. The unit will need to be sent back to AMETEK for repair. See page iii.

