

Power-Line Carrier RF Hybrids Balanced & Skewed

System Manual

CH44-VER06



AMETEK[®]
POWER INSTRUMENTS

AMETEK Power Instruments
4050 N.W. 121st Avenue
Coral Springs, FL 33065
1-800-785-7274
1-954-344-9822
www.ametekpower.com

Pulsar

THE BRIGHT STAR IN UTILITY COMMUNICATIONS

February 2018

Pulsar



IMPORTANT

We recommend that you become thoroughly familiar with the information in this manual before energizing your hybrid unit. Failure to do so may result in injury to personnel or damage to the equipment, and may affect the equipment warranty.

AMETEK does not assume liability arising out of the application or use of any product or circuit described herein. AMETEK reserves the right to make changes to any products herein to improve reliability, function or design. Specifications and information herein are subject to change without notice. All possible contingencies which may arise during installation, operation, or maintenance, and all details and variations of this equipment do not purport to be covered by these instructions. If you desire further information regarding a particular installation, operation, or maintenance of equipment, please contact your local AMETEK representative.

Copyright ©
By AMETEK Power Instruments
ALL RIGHTS RESERVED

AMETEK does not convey any license under its patent rights nor the rights of others.

New in this Version of the Hybrids System Manual

The balanced resistive & skewed hybrids have been completely redesigned.

Most of the information contained in this manual is new.

While the concept and functionality is the same, no references to the previous manual are made in this version of the manual.

Schematics are available upon request.

Preface

Scope

This manual describes the operation, specifications, features and typical applications of the Balanced Hybrid (CH20-BALMN-001) and the Skewed Hybrid (CH20-SKWMN-001). The former sometimes referred to as B and the latter S. It is intended primarily for use by engineers and technicians involved in the installation, alignment, operation, and maintenance of the hybrid assemblies.

Equipment Identification

Each hybrid assembly is identified on its nameplate.

Production Changes

When engineering and production changes are made to one of the hybrid assemblies, a revision notation is reflected on the part number, related schematic diagram, and associated parts information.

Warranty

Our standard warranty extends for 10 years after shipment. For all repaired units or advance replacements, the standard warranty is 90 days or the remaining warranty time, whichever is longer. Damage clearly caused by improper application, repair, or handling of the equipment will void the warranty.

Equipment Return & Repair Procedure

To return equipment for repair or replacement:

1. Call your AMETEK representative at **1-800-785-7274** or e-mail us at *repair.pulsar@ametek.com*.
2. Request an **RMA number** for proper authorization and credit.
3. Carefully pack the equipment you are returning.

When returning any equipment, pack it in the original shipping containers, if possible. Any damage due to improperly packed items will be charged to the customer, even when under warranty.

4. Make sure you include your return address and the RMA number on the package.
5. Ship the package(s) to:

AMETEK Power Instruments
4050 NW 121st Avenue
Coral Springs, FL USA 33065

Table of Contents

Chapter No.		Page No.
1.	Ordering Information	1-1
2.	Purpose, Basic Operation & Testing	2-1
3.	Specifications	3-1
4.	Chassis	4-1
5.	Balanced Hybrid / Balance Transformer	5-1
6.	Skewed Hybrid	6-1
7.	Typical Applications	7-1
	Two Transmitters	7-2
	Single FSK Bi-Directional Channel	7-2
	Dual FSK Bi-Directional Channel	7-2
	ON/OFF DCB with FSK Bi-Directional Channel	7-2
	ON/OFF DCB with Dual FSK Bi-Directional Channel	7-3
	Balance Transformer for Phase-to-Phase Coupling	7-3
	Balanced Combiner for Phase-to-Phase Coupling	7-3

Chapter 1. Ordering Information

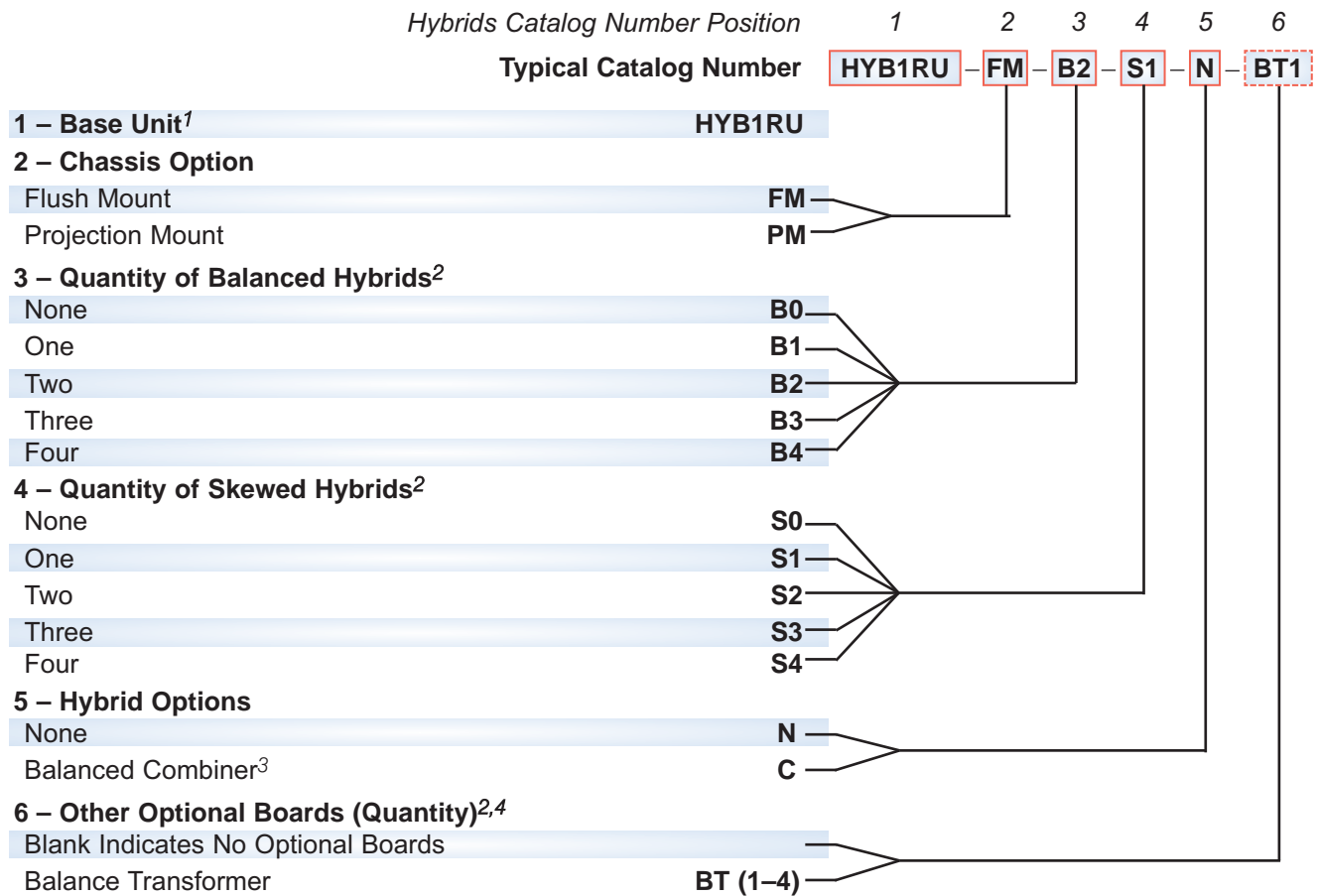

Notes:

¹ Hybrids are shipped with the following defaults:

- All empty chassis slots already have blank rear cover plates installed automatically & are included in the price of the chassis. Additional spare blank rear cover plates must be purchased separately.
- Viewed from the front, hybrids are inserted into the chassis from left to right. Balanced hybrids first, followed by any skewed hybrids, then any optional boards.
- Viewed from the front, optional boards are inserted from right to left.

² Max number of boards in a chassis is 4. So the total number of Balanced (B) + Skewed (S) + Optional Boards can not exceed 4. For example, HYB1RU-FM-B3-S2-N is an invalid number because it calls for 5 hybrids total (B3, S2).

³ Balanced combiner includes interconnecting cables and requires position 3 to be “B4”. This option is for redundancy in phase-to-phase coupling schemes.

⁴ Position 6 is only used when an optional board is present. Otherwise this catalog number position is blank.

Table 1–1. Hybrids and Chassis.

Description	Part Number	Equivalent Old Hybrid Type
Balanced Hybrid (Resistive)	CH20-BALMN-001	Resistive H1RB or H1RB-40
Skewed Hybrid (Resistive)	CH20-SKWMN-001	Skewed H1SB or H1SB-R
Balance Transformer	CH20-BALMN-002	Resistive H1RB or H1RB-40
1RU Chassis Flush Mounting	1088-780	670B695H01 (2RU Mounting Plate)
1RU Chassis Projection Mounting	1088-824	670B695H01 (2RU Mounting Plate)

Table 1–2. Hybrid Accessories.

Description	Part Number	Main Purpose
Projection Mounting Brackets	1088-820	Change Flush Chassis to Projection Mount
Blank Rear Cover Plate (1 Slot)	1088-834	Cover a Rear Slot after Removing a Hybrid
Coax Cable Male BNC-BNC 1.5 ft.	01W1-COAX2-111	Interconnect Hybrids & Carrier Sets
Coax Cable Male BNC-BNC 5 ft.	01W1-COAX5-111	Interconnect Hybrids & Carrier Sets
Coax Cable Male BNC-BNC 12 ft.	01W1-COAXA-111	Interconnect Hybrids & Carrier Sets
Male BNC to Female UHF Adapter	01NC-A8313-000	Mate RG213/RG8 Coax Directly to Output
BNC “T” Connector	01NC-UG274-000	Parallel Receivers onto Hybrid RX Port

Chapter 2. Purpose, Basic Operation & Testing

2.1 Purpose & Basic Operation

Hybrids have been used from the beginning with Power-Line carrier and their basic operation is still the same as when they originally were developed many years ago. The hybrid's primary purpose is to combine multiple Power-Line carrier (PLC) signals onto one common coax cable without causing interference between different transmitters or between the transmitters and receivers. This is necessary because two transmitters connected directly together will load each other down and can cause signal clipping and intermodulation distortion. Also a local high powered transmitter can interfere with a local receiver that is set to receive a weak signal level from the far-end transmitter. Hybrids solve these issues by providing isolation between the two devices being combined while at the same time allowing them to be combined onto a common coax without too much signal loss. Isolation is especially important when there is close frequency spacing between carrier sets which is most often the case. Using hybrids allows the minimum frequency spacing between carrier sets.

Hybrids are completely bi-directional and have nothing in them to direct signal flow from the inputs to the output or vice versa. They act as a combiner in one direction and a splitter in the opposite direction. So, going in one direction at the transmitting end of the line, the hybrid combines, but at the receiving end of the line it splits. The hybrid labelling of the "inputs" and the "output" is for the local transmitter's signal direction.

The application of a "balance transformer" used in phase-to-phase coupling at the transmitting end, for example, is a hybrid being used backwards as a splitter instead of a combiner. In this example, the output becomes the input and the 2 inputs become outputs.

PLC hybrids are completely passive devices and consist only of transformers, resistors, capacitors, and inductors (depending on the type of hybrid). All components are rated to handle more power than is specified on their inputs. This type of design adds to their long life and robustness.

2.1.1 Multiple Transmitters/Receivers

If multiple transmitters and receivers need to be combined onto one coax cable, then the hybrids can be stacked together to achieve this. This is necessary as each hybrid can only combine 2 devices at one time. So, if 3 devices need to be combined, then normally 2 hybrids will be required, if 4 devices, then 3 hybrids and so forth. The exception is that hybrids are not needed to isolate high impedance receivers from one another as receivers can be directly connected together.

2.1.2 Hybrid Types

There are two main types of PLC hybrids: Balanced (B) and Skewed (S). The balanced hybrid has equal losses from the inputs to the output. And the skewed hybrid has unequal (skewed) losses from the inputs to the output. The skewed hybrid is only used for combining a transmitter and receiver, never for 2 transmitters. When 2 transmitters are combined, the balanced hybrid is always used. The skewed hybrid favors the transmit's side over the receive side with less than 0.5 dB loss on the transmit side. (See Table 2-1). This is done to improve the overall system signal-to-noise ratio by 3dB by getting 3dB more transmit power out to the line. At the receive end of the power line, both the signal and the noise get equally attenuated so more loss on the receive side doesn't affect the S/N ratio. At the transmit end, only the transmit signal gets attenuated as it goes out to the power-line so we want to keep attenuation low.

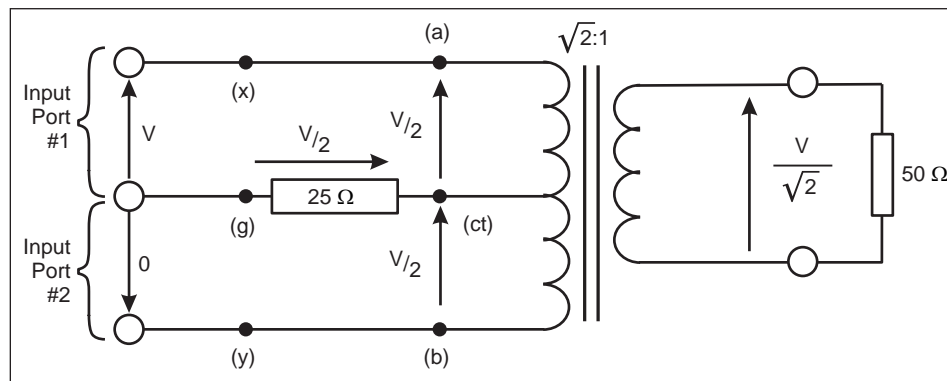

Figure 2–1.
Resistive Hybrid.

A basic balanced hybrid can be used to illustrate how it isolates two inputs from one another and matches impedances as shown in Figure 2–1. The hybrid acts as a balanced bridge network and when the output's load resistance is exactly twice the center tap resistor value you get infinite loss, theoretically, between the 2 inputs. The hybrid, in this case, is made up of a resistor of 25 ohms, and a transformer with a center tap on the primary. The transformer turns ratio is $\sqrt{2}/1$ with the $\sqrt{2}$ turns on the center tapped primary.

Let's assume the secondary of the transformer is terminated with a 50 ohm resistor and a voltage (V) is applied to input port #1. The 50 ohm load will be reflected in the primary of the transformer as a 25 ohm quantity from point (a) to the center tap (ct). This is because there is 1 turn on the primary, (a) to (ct), for every $\sqrt{2}$ turns on the secondary. The impedance will be transferred as the square of the

turns ratio, which in this case is 2 to 1. The voltage V will divide equally between the 25 ohm resistor and the 25 ohm reflected load into the top half of the primary. Thus each voltage has a value of $V/2$, and in the direction as shown. Since the center tapped primary of the transformer will act as an autotransformer, a voltage $V/2$ will also appear on the other half of the primary between point (ct) and (b). The voltage appearing across input port #2, due to the voltage V at input port #1, is the sum of the voltages around the loop from (g) to (y). This resultant voltage is 0 volts. And as shown in Figure 2–1, the hybrid isolates the voltage at one input port from the other input port. A price must be paid for this isolation and that is in the loss from the inputs to the output. One half the power is dissipated for each input in the center tap balance resistor causing a 3 dB minimum loss in the power going to the output from each input.

2.2 Ideal Hybrid Characteristics

- Two input ports are completely isolated from one another.
- Two input ports have no loss to the output port.
- Internal balance port $Z =$ Output port's connected Z
(There is infinite isolation for inputs when these impedances are exactly equal.)

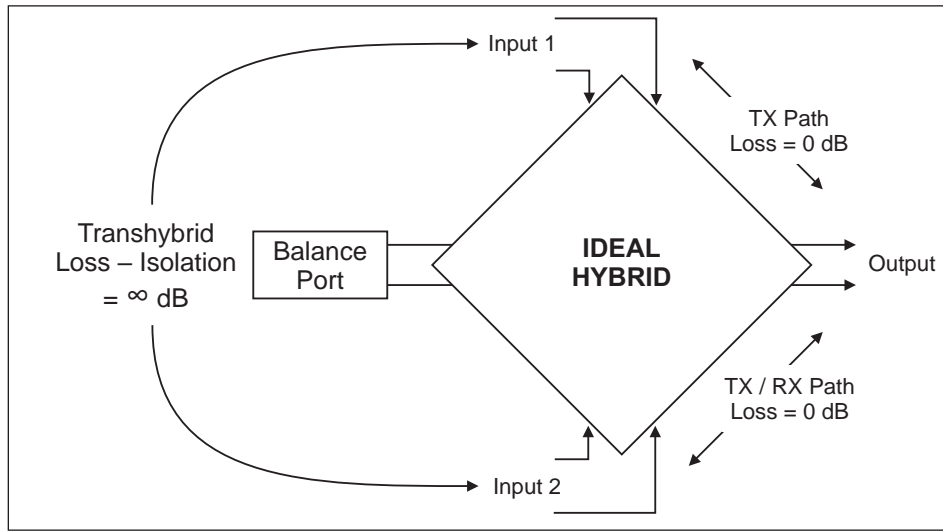

Figure 2-2.
Ideal Hybrid Characteristics.

Table 2-1. Hybrid Losses.

Hybrid Type:	Ideal	Balanced	Skewed
Insertion Loss Loss IN 1 to OUT:	0 dB	3.5 dB Max	0.5 dB Max
Insertion Loss Loss IN 2 to OUT:	0 dB	3.5 dB Max	14.5 dB Max
Transhybrid Loss* Isolation IN 1 to IN2:	∞ dB	30 dB Min	40 dB Min

* With exact impedance matching on output.

2.3 Testing

There are no adjustments necessary for the hybrids, but testing for correction operation is recommended. A frequency selective voltmeter is recommended to verify proper operation of the hybrids. See list of suggested suppliers below.

Table 2–2. Test Equipment.

High Impedance Frequency Selective Meter (30–535 kHz)
PowerComm Solutions PCA-4125
Signal Crafters Model 110
Spectrum Analyzer (Various Suppliers)

1. Check losses (between inputs and from each input to output) per the specification tables to see if within expected range using a frequency selective voltmeter.

When measuring isolation between inputs, measure frequency F1 going into input 1 and verify that the same frequency is at least 20 dB lower on input 2 with the output of the hybrid connected to a 50 Ω * load or to a line tuner with less than 10% reflected power. The higher the reflected power is between the output and the line tuner then the worse (lower) the isolation will be between the two inputs. When the line tuner is equal to 50 Ω * for the TX frequency then the isolation will be at a maximum.

When measuring the level of one particular frequency, compare the level of that frequency at the input versus the output and verify that the loss does not exceed the value in the specifications table.

2. The whole system should be connected when doing this test. If it is not connected to the coupling capacitor (CCVT), use a power-line simulator on the line side of the Line Tuner .

**(or 75 Ω depending on hybrid setting)*

Chapter 3. Specifications

Table 3–1. General Chassis Specifications.

Specification	Value
Temperature Range	–20° to +60° C
Hybrid Capacity	Up to 4 Hybrids
Mounting Space (Normal Operation)*	1 RU, No Blank Space Required Above or Below
Mounting Space (High Power Operation)**	1 RU, with an Additional 1 RU Above & Below

** All Transmitters ≤ 15 W. ** Transmitters > 15 W.*

Table 3–2. Single Chassis: Weight & Dimension Specifications

Equipment	Net Weight		Height		Width		Depth		Rack Space
	lbs	Kg	inches	mm	inches	mm	inches	mm	
with 4 Hybrids	7	3.2	1.72	43.7	19.0	483	12.9	328	1 RU

Table 3–3. Balanced Hybrid Specifications.

Specification	Value
Frequency Range	30–535 kHz
Max Power Each Input	25 Watts
Input 1 & Input 2 Impedance	50 Ohms
Output Impedance	50 or 75 Ohms
Insertion Loss: Each Input to Output*	3.5 dB Max
Transhybrid Loss: Isolation Between Inputs*	30 dB Min

* With Exact Impedance Matching on Output

Table 3–4. Skewed Hybrid Specifications.

Specification	Value
Frequency Range	30–535 kHz
Max Power TX Input	100 Watts
TX Port Impedance	50 Ohms
RX Port Impedance	50 Ohms or High Z (Open)
Output Port Impedance	50 Ohms
Insertion Loss: TX Port to Output*	0.5 dB Max
Insertion Loss: Output to RX Port *	14.5 dB Max
Transhybrid Loss: Isolation Between Inputs*	40 dB Min

* With Exact Impedance Matching on Output

Chapter 4. Chassis

4.1 Hybrid Chassis

4.1.1 General

Please refer to Figure 4–1. The hybrid chassis is a 1 RU tall chassis holding up to 4 hybrids. It was designed to extend back slightly further than the carrier set so that its connections are easily accessible. The hybrids themselves insert from the rear of the chassis, sliding into horizontal card guides until the test points protrude through the front panel. So it is important to not run any wiring across the rear of this 1 RU chassis that would prevent the hybrids from being added or removed in the future. The hybrids are held in place by 2 Captive mounting screws on the hybrid connector plate. Empty slots are covered with a blank cover plate that also screws on.

Notes:

Hybrids are shipped with the following defaults:

1. Any empty chassis slots have blank rear cover plates installed automatically & included in the price of the chassis. Additional blank rear cover plates must be purchased.
2. Viewed from the front, hybrids are inserted into the chassis from left to right. Balanced hybrids are first, followed by any skewed hybrids. Viewed from the front, all optional boards are inserted from right to left. If no Balanced hybrid exists, then the Skewed hybrid will be in the left most slot.

4.1.2 Rear

There is a chassis ground stud (#8-32 screw) that should always be grounded to earth ground using a reasonably short #10 gauge wire or larger for optimum surge protection. This ground connection satisfies the Ametek requirement to have the shield of the coax grounded when coming into the panel before getting to the carrier sets. Although, if desired, the customer may ground the coax shield on a terminal block before coming into the hybrid.

Again, it is important to not run any wiring across the rear of this 1 RU chassis that would prevent the hybrids from being added or removed in the future.

4.1.3 Front

The front of the chassis is standard for each of the 4 slots, except for optional boards. The test points are either black or red in order to indicate which type of hybrid is plugged into a particular slot. Any optional board will have its own special label covering the standard front slot label.

As noted on the front panel:

- **Black** test points extend through the front panel for the Balanced hybrid or optional board(s).
- **Red** test points are on the Skewed hybrid. The *red labels* underneath the test points apply to the *Skewed hybrid only*.

Please refer to Figure 4–1.

4.1.4 Mounting

The chassis has ventilation holes on the sides and top/bottom.

Typically the chassis mounts flush to the front of the panel. On chassis 1088-780 the flush mounted brackets are integral to the unit.

But if desired, the unit can be projection mounted by ordering chassis 1088-824 with separate (not integrated) projection-mount angle brackets. The two choices are listed under the hybrid accessories. (See Chapter 1). The brackets may be turned forward-facing or rear-facing depending on how much projection mounting offset is needed.

Please refer to Figures 4–2 & 4–3.

Normal Operation

All Transmitters $\leq 15 W$:

The chassis may be mounted without any space separating it and the device above or below it.

High Power Operation

Transmitters $> 15 W$:

We recommend leaving 1 RU of space above and below the hybrid chassis in order to operate at up to 60° C ambient temperature.

Figure 4-1. Front and Rear Panel.

Front

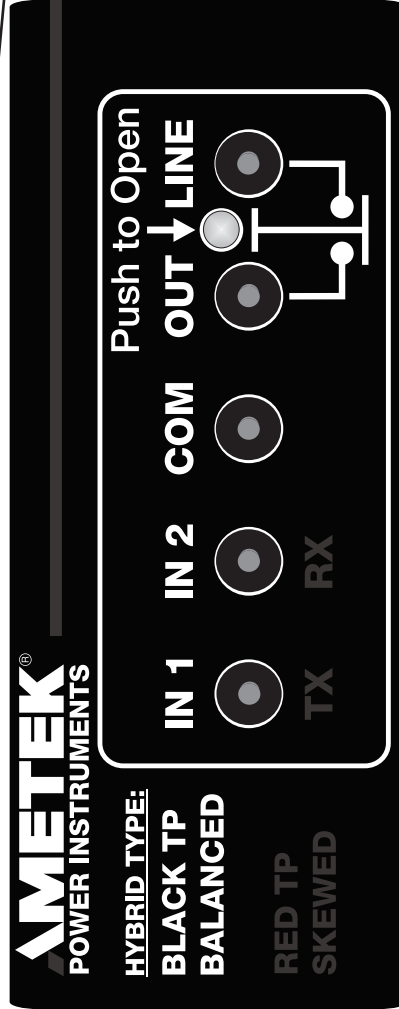
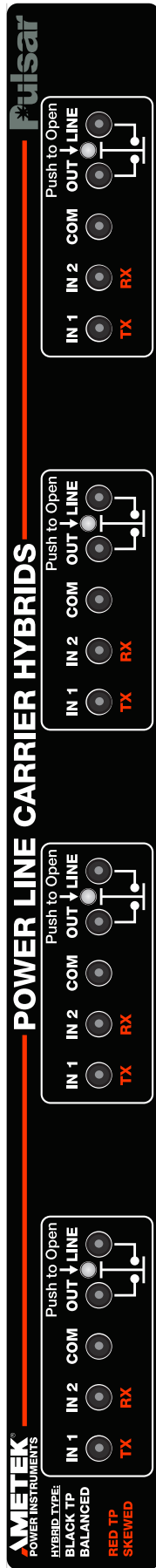

Front View Expanded

Rear

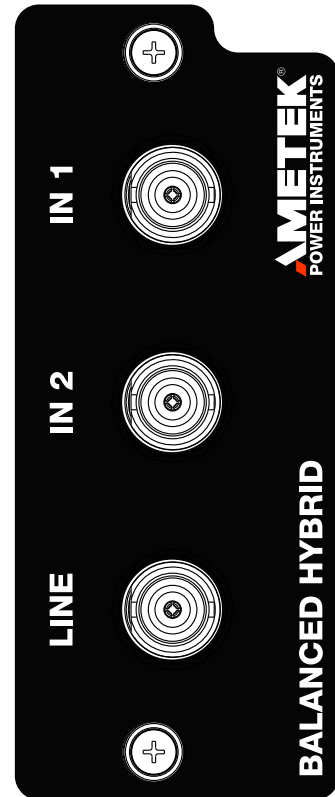

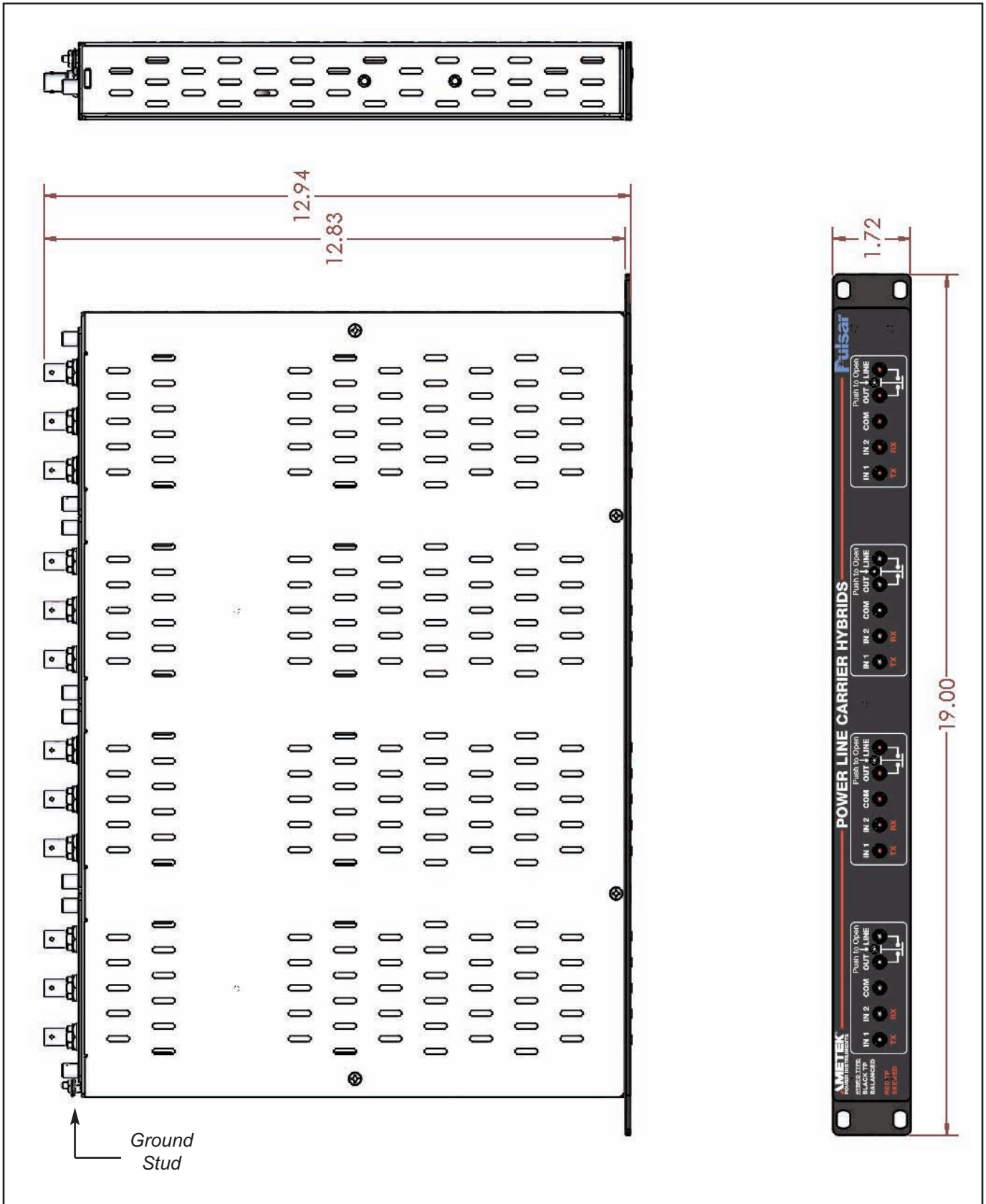

Figure 4-2. Standard Mounting.

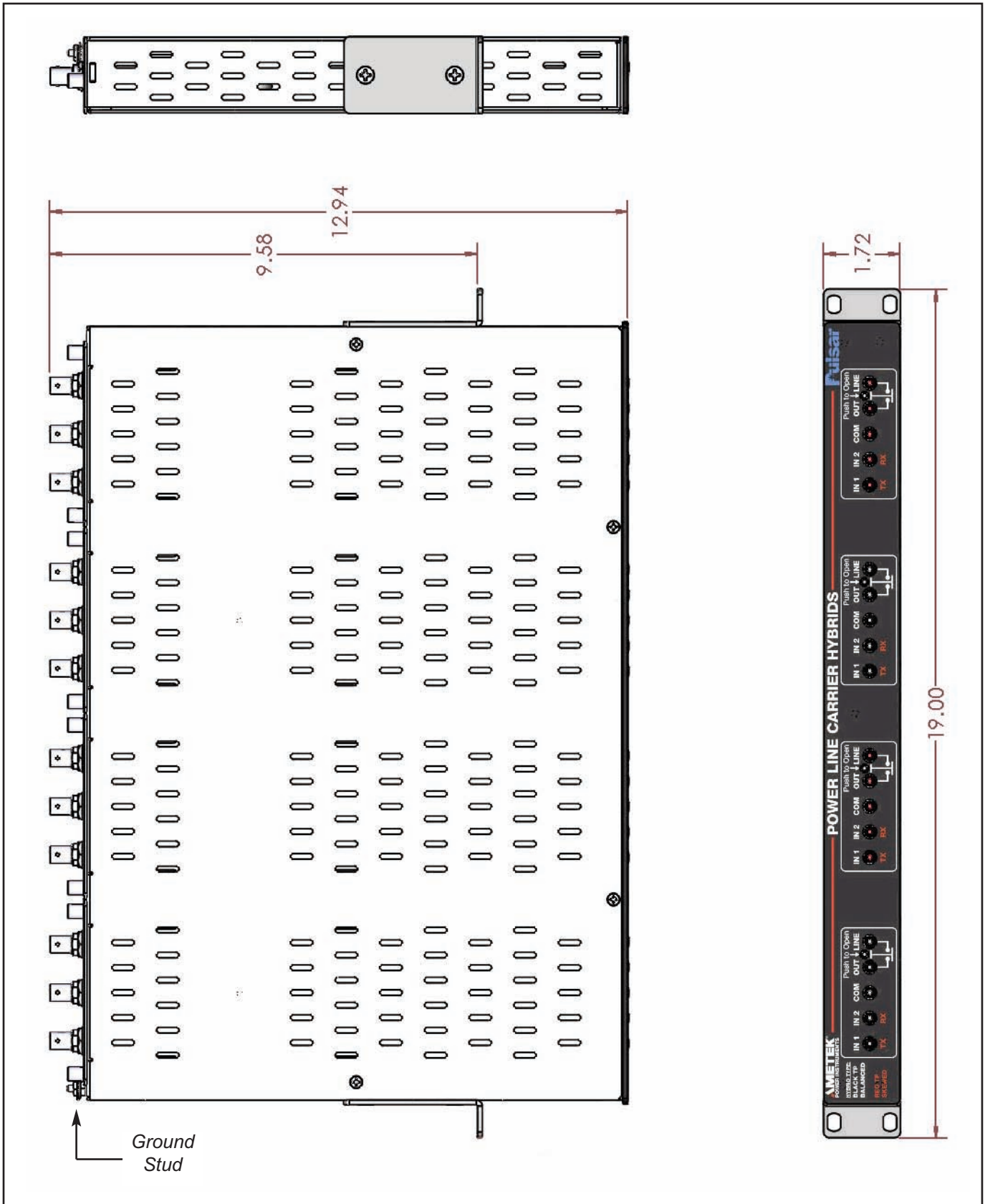

Figure 4-3. Projection Mounting.

Chapter 5. Balanced Hybrid / Balance Transformer

5.1 Description

The balanced hybrid can be used to connect two transmitters or a transmitter and receiver together, although usually a skewed hybrid is used to connect a transmitter and receiver together. The back plate contains 3 female BNC connectors (IN 1, IN 2, and Line) which are the only connections that need to be made to the hybrid. If desired, a male BNC to female UHF adapter accessory is available for changing the output connector to UHF (See Chapter 1). A gas tube protector is also located across the Line coax connector to limit surge energy coming into the hybrid.

A balance transformer is just the same as a balanced hybrid operated in the reverse direction. The 2 inputs become 2 outputs and the one output becomes an input. The front & rear labels are different than the balanced hybrid as a result. Also the board's chassis location (front view) is the far right slot(s) due to the affixed special front label needed for it. It is typically used for phase-to-phase coupling applications.

5.2 Customer Interface Points

5.2.1 Jumpers

- JMP1 (Line Z) = 50 or 75 Ω .

Shipped setting = 50 Ω .

JMP1 is used for setting the output impedance of the line port which is generally 50 Ω in the USA.

- JMP2 = Switch Enable or Disable.

Shipped setting = SW Enable.

JMP2 is used to enable or disable the front pushbutton switch. For customers not desiring the switch, it gives them a way of jumpering it out of the circuit.

5.2.2 Test Points for Balanced Hybrid (Black)

- Input 1 – For IN1 Coax connector

- Input 2 – For IN2 Coax connector
- Common – This is the common for all the test points
- Output – This is the Test Point *before* the in-line pushbutton switch
- Line – This is the Test Point *after* the in-line pushbutton switch. Electrically tied to the Output Test Point unless the pushbutton switch is pressed

5.2.3 Test Points for Balance Transformer (Black)

- Output 1 – For OUT1 Coax connector
- Output 2 – For OUT2 Coax connector
- Common – This is the common for all the test points
- Input – This is the Test Point *before* the in-line pushbutton switch
- Line – This is the Test Point *after* the in-line pushbutton switch. Electrically tied to the Input Test Point unless the pushbutton switch is pressed

5.2.4 Pushbutton Switch

NOTE: The pushbutton switch is recessed to prevent accidental activation. Use a narrow tool such as a pocket screwdriver to press it.

SW1 – This is a normally closed front panel pushbutton switch that allows for an in-line reflective power meter to be inserted between the Output and Line test points when pressing this switch.

When using this switch, the in-line meter is always inserted into the test points first, and then the pushbutton is pressed for the measurement and released before removing the meter.

This prevents loss of the carrier signal when inserting the meter, therefore, there is no need to take the system out of service when properly using this switch.

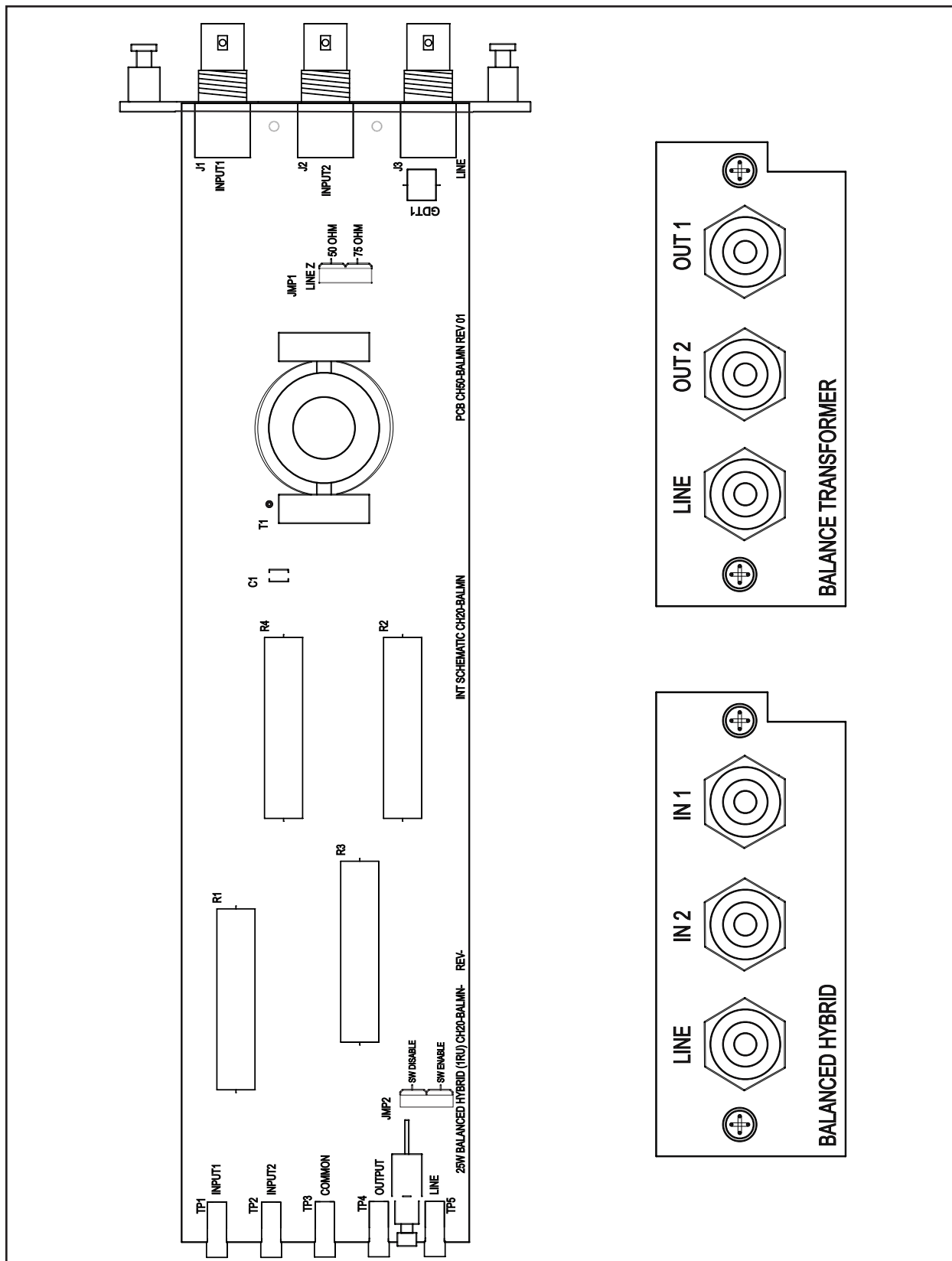

Figure 5-1. Balanced Hybrid.

Chapter 6. Skewed Hybrid

6.1 Description

The skewed hybrid can only be used to connect a transmitter and receiver(s) together, as it has too much loss on the RX port for a transmitter to be connected to this port. The back plate contains 3 female BNC connectors (TX, RX, and Line) which are the only connections that need to be made to the hybrid. If desired, a male BNC to female UHF adapter accessory is available for changing the output connector to UHF (See Chapter 1). A gas tube protector is also located across the Line coax connector to limit surge energy coming into the hybrid.

6.2 Customer Interface Points

6.2.1 Jumpers

- JMP1 (RX Port) = High Z or Terminate.
Shipped setting = Terminate.

JMP1 is used to put a 50 Ω high power resistor across the RX port for terminating high input impedance receivers. When connecting to a circuit that has receivers with an already existing 50 Ω termination, then this jumper should be set to the High Z position.

- JMP2 = Switch enable or disable.
Shipped setting = SW Enable.

JMP2 is used to enable or disable the front pushbutton switch. For customers not desiring the switch, it gives them a way of jumpering it out of the circuit.

6.2.2 Test Points (Red)

- TX– For TX Coax connector
- RX– For RX Coax connector
- Common – This is the common for all the test points
- Output – This is the Test Point *before* the in-line pushbutton switch
- Line – This is the Test Point *after* the in-line pushbutton switch. Electrically tied to the Output Test Point unless the pushbutton switch is pressed

6.2.3 Pushbutton Switch

NOTE: The pushbutton switch is recessed to prevent accidental activation. Use a narrow tool such as a pocket screwdriver to press it.

SW1 – This is a normally closed front panel pushbutton switch that allows for an in-line reflective power meter to be inserted between the Output and Line test points when pressing this switch.

When using this switch, the in-line meter is always inserted into the test points first, and then the pushbutton is pressed for the measurement and released before removing the meter.

This prevents loss of the carrier signal when inserting the meter and therefore there is no need to take the system out of service when properly using this switch.

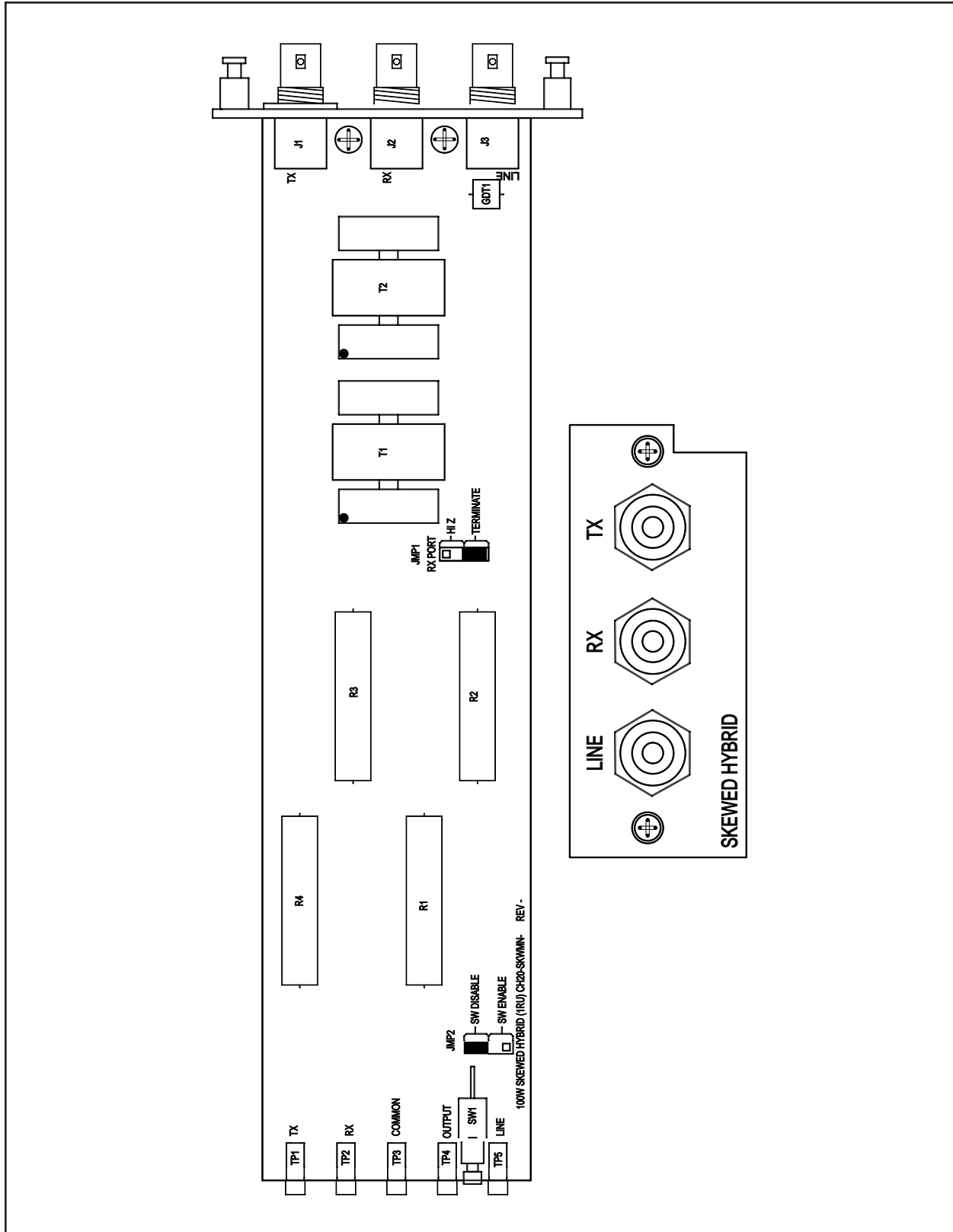

Figure 6–1. Skewed Hybrid.

Chapter 7. Typical Applications

7.1 Application Notes on Applying Hybrids:

- All Ametek/Pulsar ON/OFF Carrier systems are designed to have their TX & RX bridged directly together in 2-wire mode without hybrids. (See Figures 7-4 & 7-5)
- A Balanced Hybrid should always be used if combining 2 Transmitters. Never use a Skewed hybrid for this application. (See Fig. 7-1)
- A Skewed Hybrid will give 3 dB less TX loss and thus a 3 dB improvement in signal to noise ratio so it is the recommended hybrid for combining a FSK carrier set TX & RX together. (See Fig. 7-2)
- Hybrids should be arranged with the lesser losses in the transmitter path and the greater losses in the receiver path to provide more transmitter signal levels onto the power line.
- ON/OFF DCB Carrier systems should be arranged with less losses than FSK systems when combining together with hybrids where possible, as they need higher signal/noise ratios than FSK systems. (See Fig. 7-5)
- If possible transmitters used for common applications should be arranged for equal attenuation. For example, it is ideal to have Dual channel DTT Transmitters combined through the same balanced hybrid. (See Fig. 7-3)
- If required, to split signals instead of combining, a balance transformer is used. The balance transformer is equal to a balanced hybrid in reverse. This is done to split signals for phase-to-phase coupling to two different phases of the power-line. (See Fig 7-6)
- For redundancy, where no single point of failure is allowed in a phase-to-phase coupled system, a balanced combiner hybrid arrangement can be used where 4 balanced hybrids are interconnected. If any one hybrid fails, at least one of the systems (Primary or Backup) continues to work . (See Fig. 7-7)

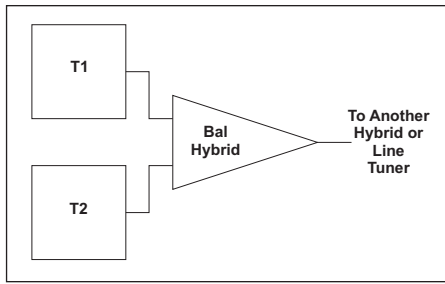

Figure 7-1.
Two Transmitters.

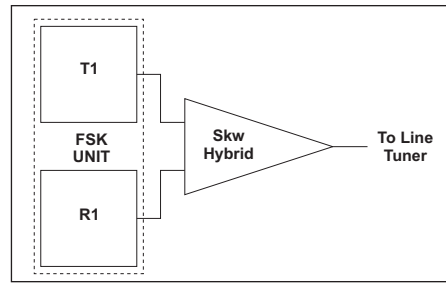

Figure 7-2.
Single FSK Bi-Directional Channel.

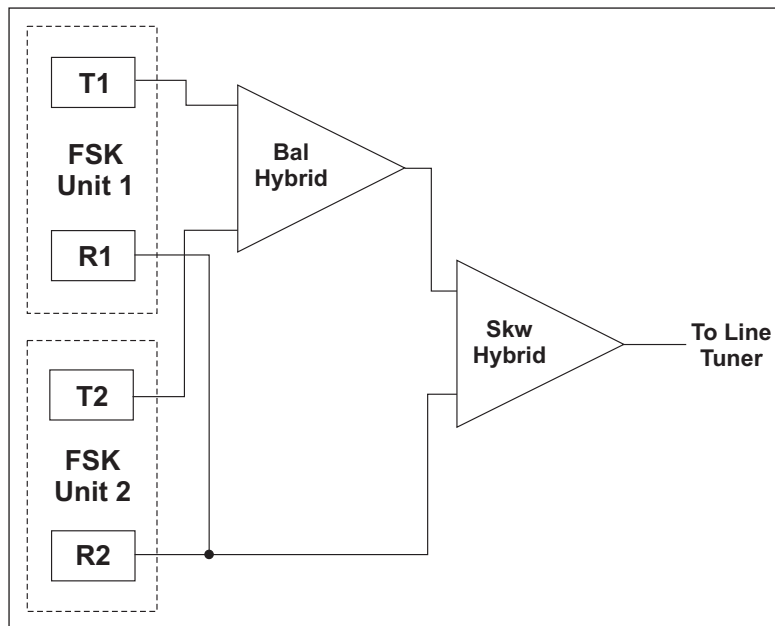

Figure 7-3. Dual FSK Bi-Directional Channel.

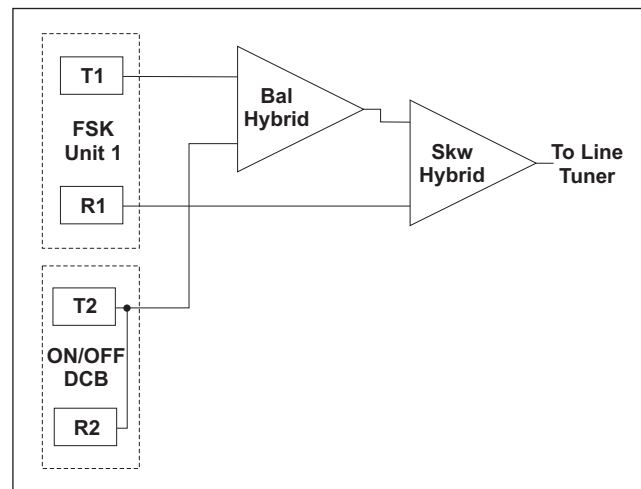
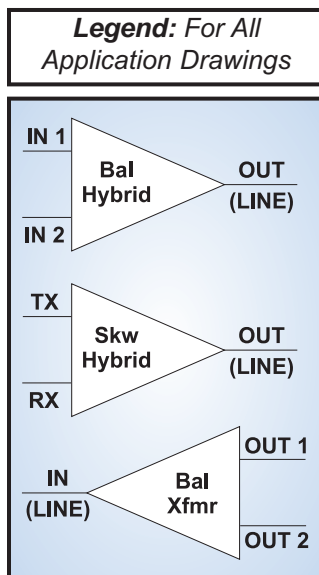

Figure 7-4.
ON/OFF DCB with FSK Bi-Directional Channel.

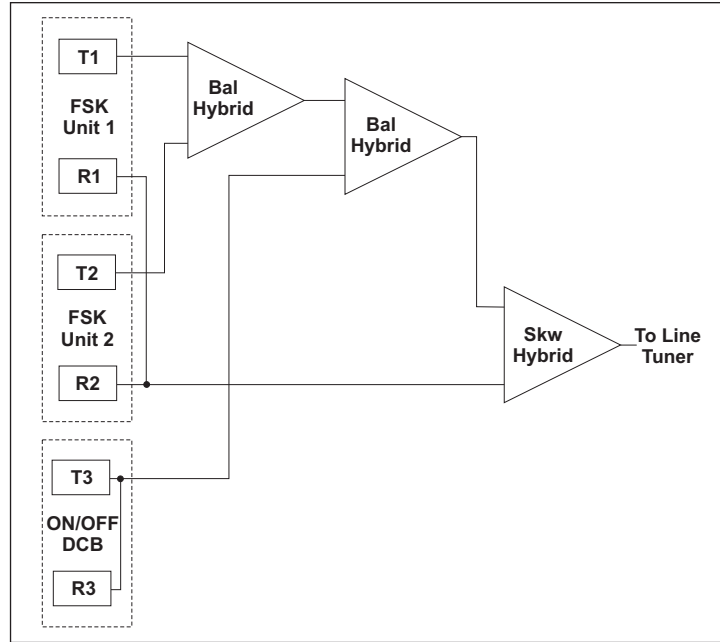

Figure 7-5.
ON/OFF DCB with Dual FSK Bi-Directional Channel.

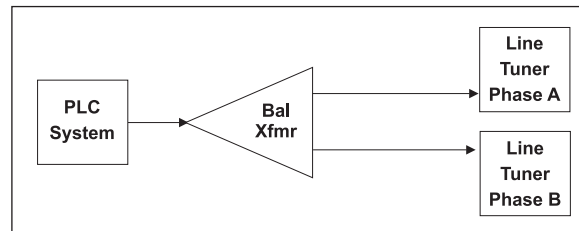

Figure 7-6.
Balance Transformer for Phase-to-Phase Coupling.

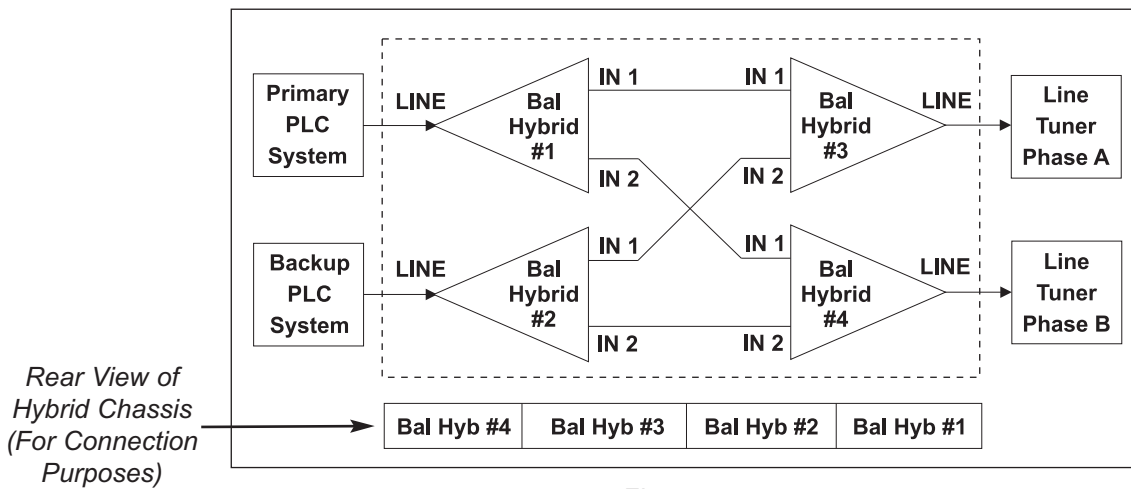

Figure 7-7.
Balanced Combiner for Phase-to-Phase Coupling.

Pulsar