

Smart Gap



Instruction Manual C044-GAPV3



AMETEK Power Instruments
4050 NW 121st Avenue
Coral Springs, FL 33065
1-800-785-7274
1-954-344-9822
www.ametekpower.com



IMPORTANT

We recommend that you become thoroughly familiar with the information in this manual before energizing your system. Failure to do so may result in injury to personnel or damage to the equipment, and may affect the equipment warranty.

AMETEK does not assume liability arising out of the application or use of any product or circuit described herein. AMETEK reserves the right to make changes to any products herein to improve reliability, function or design. Specifications and information herein are subject to change without notice. All possible contingencies which may arise during installation, operation, or maintenance, and all details and variations of this equipment do not purport to be covered by these instructions. If you desire further information regarding a particular installation, operation, or maintenance of equipment, please contact your local representative.

Copyright ©
By AMETEK
ALL RIGHTS RESERVED

AMETEK does not convey any license under its patent rights nor the rights of others.

Preface

Scope

This manual describes the functions and features of the Smart Gap. It is intended primarily for use by engineers and technicians involved in the installation, alignment, operation, and maintenance of the substation equipment.

Equipment Identification

Each unit is identified on the pc board.

Production Changes

When engineering and production changes are made to this assembly, a revision number is reflected on the part number, related schematic diagram, and associated parts information.

Warranty

Our standard warranty extends for 5 years after shipment. For all repaired units or advance replacements, the standard warranty is 90 days or the remaining warranty time, whichever is longer. Damage clearly caused by improper application, repair, or handling of the equipment will void the warranty.

Equipment Return & Repair Procedure

To return equipment for repair or replacement:

1. Call your representative at **1-800-785-7274** or visit our website at www.ame-tekpower.com.
2. Request an **RMA number** for proper authorization and credit.
3. Carefully pack the equipment you are returning.

Repair work is done most satisfactorily at the factory. When returning any equipment, pack it in the original shipping containers if possible. Any damage due to improperly packed items will be charged to the customer, even when under warranty.

AMETEK also makes available interchangeable parts to customers who are equipped to do repair work. When ordering parts (modules, mounting hardware, etc.), always give the complete part number(s).

4. Make sure you include your return address and the RMA number on the package.
5. Ship the package(s) to:

AMETEK
4050 NW 121st Avenue
Coral Springs, FL USA 33065
USA

Smart Gap

Ordering Information

Part Number	Description	Suggested Application
C020-GAPMN-001	2.4 kV Smart Gap	–
C020-GAPMN-002	4.2 kV Smart Gap	For Line Tuner
C020-GAPMN-003	6.2 kV Smart Gap	For CCVT Drain Coil

Purpose

Even though carrier holes infrequently occur, they can cause mis-operations in protective relay systems utilizing Power-Line Carrier. This can result in over trips on DCB (blocking) systems, delayed trips in POTT or DTT systems, or false permission to trip in DCUB (unblock) systems. Unexplained carrier holes not only cause mis-operations but can also consume much time and expense in troubleshooting/analysis. Some utilities use extension timers in the protective relay to attempt to ride through carrier holes of certain durations, but setting this time is usually a best guess, based on field experience.

AMETEK's research and lab/field testing has shown that a spark gap in line tuners and CCVTs is the dominant cause of carrier holes, especially when no failures in the Power-Line Carrier equipment are found. This is due to these spark gaps continuing to fire after the surge is removed, because of the combined energy from the Power-Line Carrier transmitters and the residual 60 Hz energy from the CCVT that can sometimes cause the gaps to hold in the firing state even though the high voltage surge is gone. So rather than trying to mask over carrier holes, AMETEK has attacked the source by developing a Smart Gap that operates so quickly that the brief signal loss is insignificant to the overall system operation. Typical firing plus clearing speed is less than 0.5 msec.

Application

This gap has been designed to be retrofitted into existing line tuners or CCVTs to replace the existing gap which uses either a gas discharge tube (GDT) or air gap protection. All existing gas discharge tube protection in the line tuners/CCVTs must be replaced for the solution to be effective. It is possible to replace the gap in only the line tuner and to leave an air gap in the CCVT, but this air gap must be set correctly and in good condition. The idea behind the AMETEK Smart Gap is to have a very robust maintenance-free gap that you put in service and forget about.

Specifications.

Smart Gap Specification	C020-GAPMN-001	C020-GAPMN-002	C020-GAPMN-003
Typical Firing Voltage (Constant dc)	2.4 kVdc	4.2 kVdc	6.2 kVdc
Typical Firing Voltage (constant 50/60 Hz)	1.7 kV rms	3.1 kV rms	4.4 kV rms
Typical Firing Voltage (1.2 x 50 μ s Surge)	3.0 kV peak	4.2 kV peak	5.1 kV peak
Max Time Before Firing (1.2 x 50 μ s Surge)	0.3 μ s	0.3 μ s	0.3 μ s
Max Time to Extinguish Single 1.2 x 50 μ s Surge	100 μ s	100 μ s	100 μ s
Expected lifetime with no degradation in performance	> 10,000 of 1.2 x 50 μ s surges at 8kV/4kA	> 10,000 of 1.2 x 50 μ s surges at 8kV/4kA	> 10,000 of 1.2 x 50 μ s surges at 8kV/4kA
Capacitance Max @ 100 kHz	2 pF	2 pF	2 pF
50/60 Hz Max Leakage Current (non-conducting state)	50 μ A	50 μ A	50 μ A
Gas Discharge Tube Diameter	12 mm	12 mm	12 mm
Overall Physical Size (including L-bracket mounting)	2.6" x 2.4" x 2.0" (see page 1–4)	2.6" x 2.4" x 2.0" (see page 1–4)	2.6" x 2.4" x 2.0" (see page 1–4)
Nominal Wire Lead Length	6"	6"	6"
Shipping Weight	0.2 lbs	0.2 lbs	0.2 lbs

Installation

1. Any existing gaps in the CCVT and line tuner, at either end of the line, must be removed if they are the gas discharge tube (GDT) type and replaced by a Smart Gap. If they are the air gap type, at least one can be left in the system in either the CCVT or the line tuner without changing to a Smart Gap but they should be checked to see if properly set and clean.
2. The Smart Gap should be mounted on one of the screw studs of the gap being replaced, with the wire lead connected to the other stud. These connections must be securely tightened as high currents will flow through them. There is no polarity with the Smart Gap so either side can be connected to ground. The Smart Gap is electrically in parallel with the knife switch.
3. Position the Smart Gap when mounting such that it is not close (>0.25" away) to metal surfaces of the enclosure or other electrical connections. Mounting the Smart Gap so light from a flashlight can be shone through them is desirable so that any deterioration can easily be noted over long periods of time.



CAUTION

Any Power-Line Carrier transmitters operating on the line where the Smart Gap is being installed, should be temporarily taken out of service and powered down. Also the carrier ground switch, of the device the SMART GAP is being installed in, must be closed when removing the existing gap. Then remember to open the grounding switch after installation is complete and before putting the system back into service.

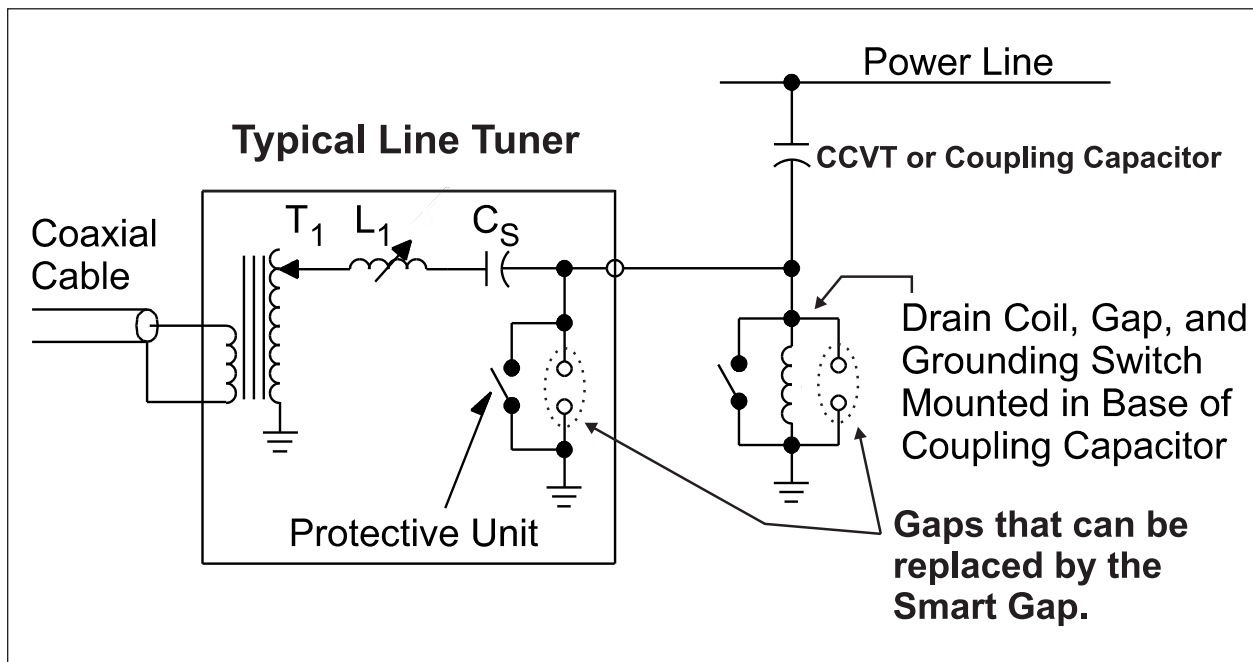

Schematic Diagram:
Single Terminal of Power-Line Carrier System Showing Smart Gap Location(s).

Smart Gap Mounting Dimensions.

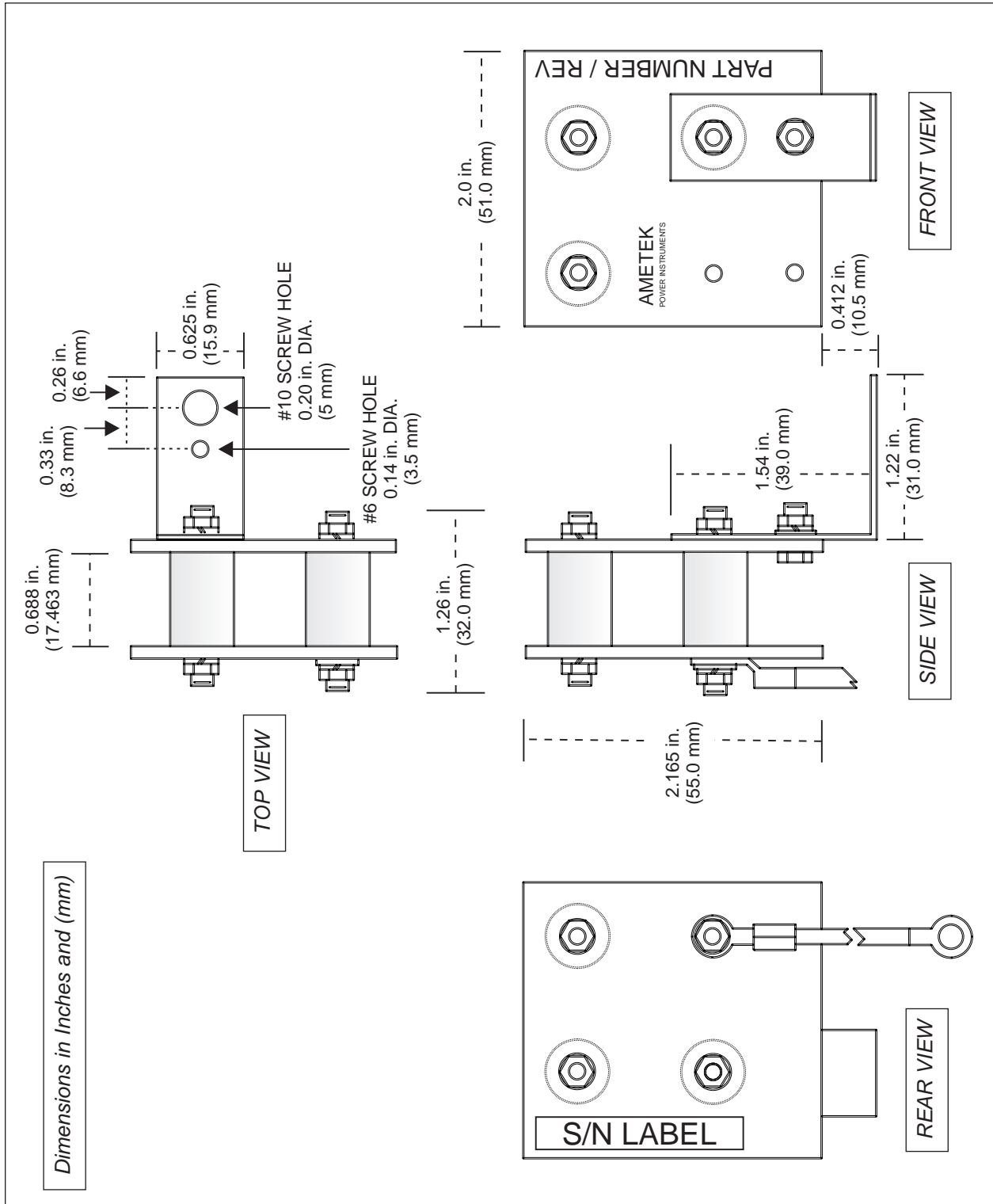

Typical Smart Gap Installations

These photographs show the Smart Gap mounted in the line tuner cabinet replacing the existing GDT gap.

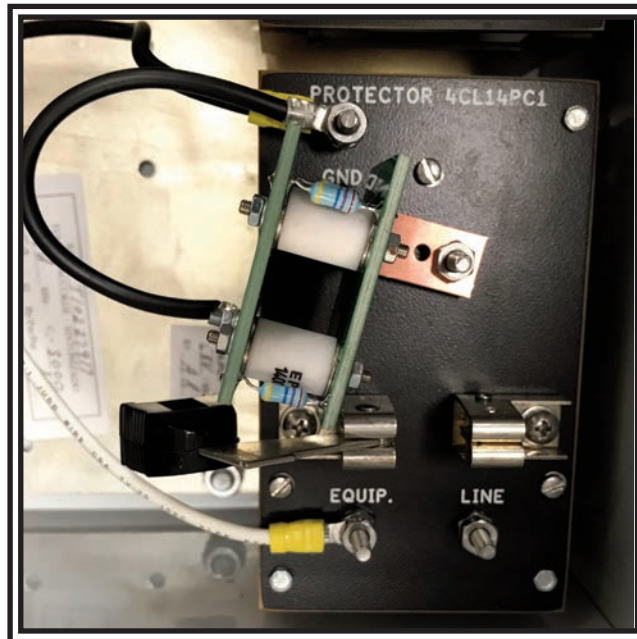

Close Up of Smart Gap in Tuner Cabinet

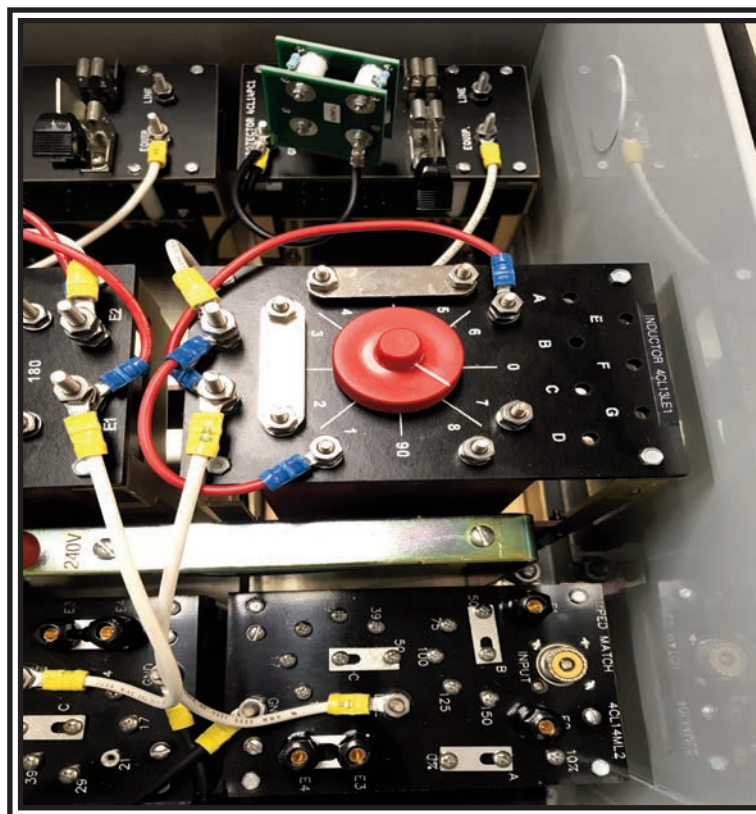

Overall View of Smart Gap in Tuner Cabinet

This photograph shows the Smart Gap in the line tuner cabinet with the existing air gap disabled by setting the air gap to its widest setting.

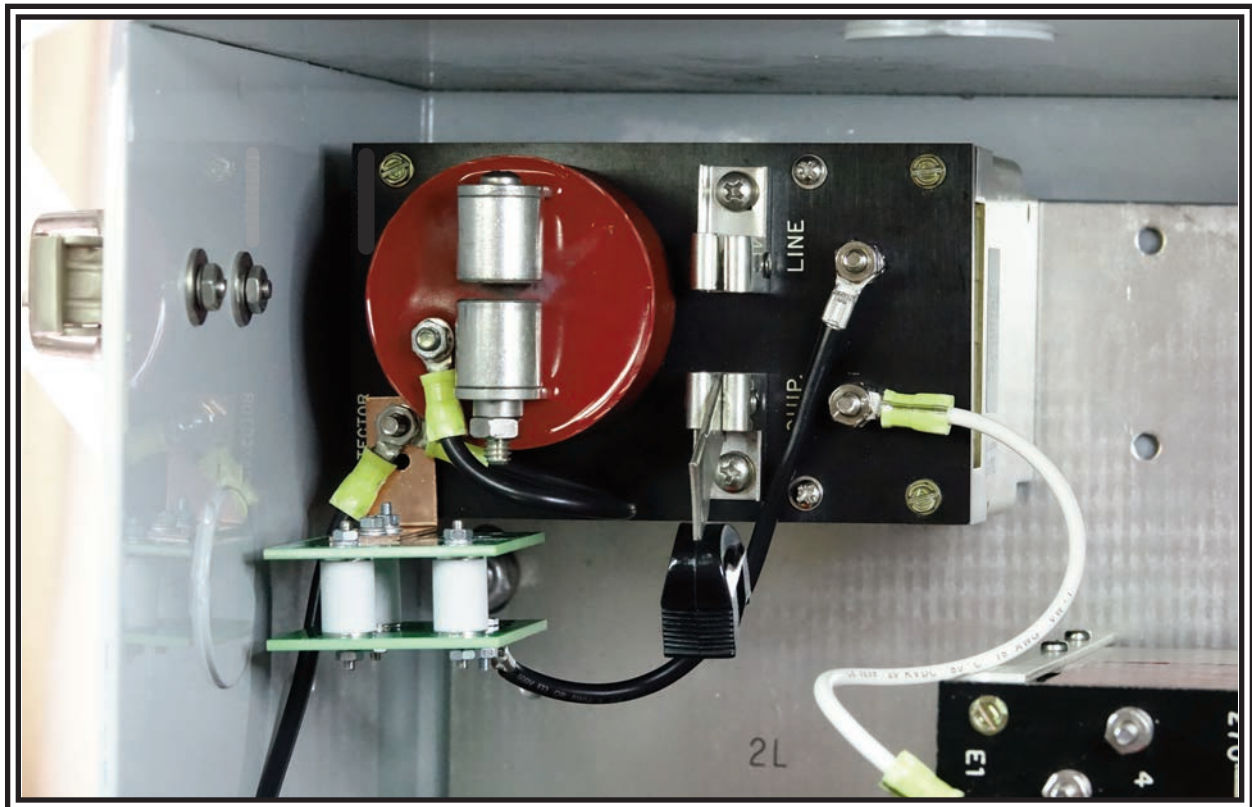

Close Up of Smart Gap with Air Gap Disabled

These photographs show the Coupling Capacitor / CCVT base housing and where the Smart Gap would be mounted on top of the drain coil replacing the existing GDT gap.



*Close Up of Smart Gap Mounted on the Drain Coil (Left)
and Location Inside Coupling Capacitor / CCVT Base Housing (Right).*

Performance Evaluation

To prove if the Smart Gap is making a difference for your system, analyze the sequence of events (SOEs), from Power-Line Carriers and/or digital fault recorders, to ensure no unintended loss of carrier signal is occurring in the event records.

For DCB blocking systems, correct operation would be evidenced by no loss of blocking carrier output during an external fault. So there should be no overtrips occurring for external faults, assuming system settings are correct and Power-Line Carrier receivers have been calibrated correctly.

For FSK mode systems correct operation would be evidenced by no loss of channel during any known transient event. Loss of channels events will still occur for high noise events.

There is still the lesser probability of other malfunctions causing carrier holes such as coax cable flashover due to deterioration or contact bounce in electromechanical relays.