

TCF-10B

FREQUENCY-PROGRAMMABLE
FREQUENCY-SHIFT CARRIER
TRANSMITTER/RECEIVER

System Manual

CF44-VER06

(Replaces CF44-VER05)



AMETEK Power Instruments
4050 N.W. 121st Avenue
Coral Springs, FL 33065
1-800-785-7274
+1-954-344-9822
www.pulsartech.com

Pulsar

TCF-10B

System Manual

Table of Contents

Product Description	1
Applications and Ordering Information	2
Installation	3
Test Equipment	4
Installation/Adjustment Procedures	5
Signal Path	6
Design Verification Tests	7
Maintenance	8
Power Supply Module	9
Keying Module	10
Transmitter Module	11
10W PA Module	12
RF Interface Module	13
Universal Receiver Module	14
Receiver Logic Module	15
Optional EM Output Module	16
Optional Voice Adapter Module	17
Optional Trip Test Unit Module	18

Important Change Notification

The following list shows the most recent publication date for each chapter. Publication dates in **bold type** indicate changes to that chapter since the previous publication. For these chapters, the specific pages that have changed are listed for easy reference. Note that only significant changes, i.e., those changes which affect the technical use and understanding of the document and the TCF-10B equipment, are reported. Changes in format, typographical corrections, minor word changes, etc. are not reported. Note also that in some cases text and graphics may have flowed to a different page than in the previous publication due to formatting or other changes. The page numbers below show the current pages on which the reported changes appear.

Each reported change is identified in the document by a change bar, || placed to its immediate left and/or right, just like the ones on this page.

<u>Chapter Number & Title</u>	<u>Publication Date</u>	<u>Pages with Changes</u>
Front Section	February 2007	ii
1. Product Description	February 2007	1-10
2. Applications and Ordering Information	December 2004	
3. Installation	December 2004	
4. Test Equipment	April 1997	
5. Installation/Adjustment Procedures	December 2004	
6. Signal Path	December 2004	
7. Design Verification Tests	December 2004	
8. Maintenance	October 2001	
9. Power Supply Module	December 2004	
10. Keying Module	December 2004	
11. Transmitter Module	December 2004	
12. 10W PA Module	December 2004	
13. RF Interface Module	December 2004	
14. Universal Receiver Module	October 2001	
15. Receiver Logic Module	December 2004	
16. EM Output Module	December 2004	
17. Optional Voice Adapter Module	February 2007	17-6
18. Optional Trip Test Unit	February 2007	18-4

Note: due to design changes, nomenclature throughout this document indicating 300, 600 & 1200 Hz has been changed to 380, 800 & 1600 Hz respectively.



IMPORTANT

We recommend that you become acquainted with the information in this manual before energizing your TCF-10B system. Failure to do so may result in injury to personnel or damage to the equipment, and may affect the equipment warranty. If you mount the carrier set in a cabinet, it must be bolted to the floor or otherwise secured before you swing out the equipment, to prevent the installation from tipping over.

You should not remove or insert printed circuit modules while the TCF-10B is energized. Failure to observe this precaution can result in undesired tripping output and can cause component damage.

PULSAR does not assume liability arising out of the application or use of any product or circuit described herein. PULSAR reserves the right to make changes to any products herein to improve reliability, function or design. Specifications and information herein are subject to change without notice. All possible contingencies which may arise during installation, operation, or maintenance, and all details and variations of this equipment do not purport to be covered by these instructions. If you desire further information regarding a particular installation, operation, or maintenance of equipment, please contact your local Pulsar Technologies, Inc. representative.

Copyright ©

By Pulsar Technologies, Inc.

ALL RIGHTS RESERVED

PULSAR does not convey any license under its patent rights nor the rights of others.

ESD Warning!

YOU MUST BE PROPERLY GROUNDED, TO PREVENT DAMAGE FROM STATIC ELECTRICITY, BEFORE HANDLING ANY AND ALL MODULES OR EQUIPMENT FROM PULSAR.

All semiconductor components used, are sensitive to and can be **damaged** by the discharge of static electricity. Be sure to observe all Electrostatic Discharge (ESD) precautions when handling modules or individual components.

Preface

Scope

This manual describes the functions and features of the TCF-10B Power Line Carrier Transmitter/Receiver. It is intended primarily for use by engineers and technicians involved in the installation, alignment, operation, and maintenance of the TCF-10B.

Equipment Identification

The TCF-10B equipment is identified by the Catalog Number on the TCF-10B chassis nameplate. You can decode the Catalog Number using the information in Chapter 2.

Production Changes

When engineering and production changes are made to the TCF-10B equipment, a revision notation (Sub number) is reflected in the style number and related schematic diagrams. A summary of all Sub numbers for the particular release is shown on the following page.

Warranty

Our standard warranty extends for 60 months after shipment. For all repaired modules or advance replacements, the standard warranty is 90 days or the remaining warranty time, whichever is longer. Damage clearly caused by improper application, repair, or handling of the equipment will void the warranty.

Equipment Return & Repair Procedure

To return equipment for repair or replacement:

1. Call your PULSAR representative at **1-800-785-7274**.
2. Request an **RMA number** for proper authorization and credit.
3. Carefully pack the equipment you are returning.

Repair work is done most satisfactorily at the factory. When returning any equipment, pack it in the original shipping containers if possible. Be sure to use anti-static material when packing the equipment. Any damage due to improperly packed items will be charged to the customer, even when under warranty.

Pulsar Technologies, Inc. also makes available interchangeable parts to customers who are equipped to do repair work. When ordering parts (components, modules, etc.), always give the complete PULSAR style number(s).

4. Make sure you include your return address and the RMA number on the package.
5. Ship the package(s) to:

Pulsar Technologies, Inc.
Communications Division
4050 NW 121st Avenue
Coral Springs, FL USA 33065

Overview of this Document

Chapter 1 – Product Description, including specifications

Chapter 2 – Applications and related catalog numbers for ordering purposes

Chapter 3 – Installation

Chapter 4 – Test Equipment

Chapter 5 – Installation/Adjustment procedures

Chapter 6 – Signal Path (for use during testing)

Chapter 7 – Design Verification procedures

Chapter 8 – Maintenance

Module circuit descriptions and troubleshooting procedures are in the remaining chapters.

The TCF-10B circuitry is divided into seven (7) standard modules. In addition, Voice Adapter, Electro-mechanical, and Trip Test Unit modules are available as options.

Contents of Carrier Set

The TCF-10B carrier set includes the style numbers, listed below, with appropriate sub numbers representing revision levels. (To determine related style numbers, you may also refer to Figure 2-25.)

Module	Style	Sub Number
Power Supply	1617C38 GXX	6
Keying	1606C50 GXX	9
Transmitter	C020-TXMNN-001	2
10W PA	1606C33 G01	21
RF Interface	1609C32 G01	9
Receiver/FSK Discriminator	C020-RXVMN-202	6
Universal Receiver	C020-RXVMN-203	7
Receiver Logic	CF20-RXLMN-0XX	6
EM Output	1606C53 G01	7
Voice Adapter	C020-VADMN-001	4
Transmitter w/Trip Test Unit	C020-TXMMN-102	2

Contents – Figures

Figure No.		Page No.
1-1	TCF–10B Transceiver Set	1–2
1-2	TCF–10B Transmitter (only) Set	1–6
1-3	TCF–10B Receiver (only) Set	1–7
1-4	Front Panel for 2-Frequency, Transfer Trip or Unblock Applications	1–8
1-5	Front Panel for 3-Frequency, Transfer Trip and Unblock Applications	1–8
1-6	Front Panel for 2-Frequency, Phase Comparison Applications	1–8
2-1	Simplified Unblock Receiver Logic	2–1
2-2	Transceiver Unit Connections, 2 Freq. set	2–2
2-3	Basic Logic Diagrams for Directional Comparison Unlocking	2–2
2-4	Basic Logic Diagrams for Underreaching Transfer Trip Systems	2–4
2-5	Basic Operation of the Dual Phase Comparison Pilot Relaying System	2–5
2-6	Basic Segregated Phase Comparison Systems	2–7
2-7	Basic Operation of the Segregated Phase Comparison System	2–9
2-8	Conventional Phase Comparison Response to an Outfeed Condition Block Tripping	2–9
2-9	Typical Threshold Setting for Offset Keying	2–9
2-10	Response of Segregated Phase Comparison System with Offset Keying	2–10
2-11	Transceiver Unit Conn. 2 Freq. set (Single Channel DTT)	2–11
2-12	Direct Transfer Trip for Transformer Protection	2–12
2-13	Direct Transfer Trip for Shunt Reactor Protection	2–12
2-14	Dual Channel Direct Transfer Trip with Throwover to Single Channel	2–13
2-15	Dual Channel Direct Transfer Trip with Throwover to Single Channel	2–13
2-16	3-Frequency System	2–15
2-17	Transceiver Unit Conn. 3 Freq. Set (Unblock Relaying and DTT)	2–16
2-18	Three Terminal line application	2–17
2-19	Hybrid Connections - Two Transmitters	2–17
2-20	Hybrid Connections - Single Bi-Directional Channel	2–17
2-21	Hybrid Connections - Dual Bi-Directional Channel	2–19
2-22	Hybrid Connections - Four Transmitters (Equal Losses)	2–19

FIGURES, Cont'd

2-23	Hybrid Connections - Four Transmitters (Unequal Losses)	2-20
2-24	20 Vdc Auxiliary Power Supply	2-23
2-25	Catalog Numbers / Module Style Numbers	2-24
3-1	Rear Panel	3-2
3-2	Cable Termination Diagram	3-4
3-3	Mechanical Outline Drawing	3-9
3-4	Connection Drawing and Jumper Options	3-10
4-1	Extender Board	4-2
6-1	Functional Block Diagram (11x17 Pull Out)	6-5
9-1	Power Supply Front Panel	9-1
9-2	Power Supply Component Location	9-4
9-3	Power Supply Schematic	9-5
10-1	Keying Module Front Panel	10-1
10-2	Keying PC Board	10-6
10-3	Keying Module Internal Logic (G01 Shift down to trip)	10-7
10-4	Keying Module Internal Logic (G03 Shift up to trip)	10-8
10-5	Keying Schematic	10-9
11-1	Transmitter Front Panel	11-1
11-2	Transmitter Component location	11-3
11-3	Transmitter Block Diagram	11-4
12-1	10W PA Front Panel	12-1
12-2	10W PA Component location	12-3
12-3	10W PA Schematic	12-4
13-1	RF Interface Front Panel	13-1
13-2	RF Interface Component location	13-3
13-3	RF Interface Schematic	13-4
14-1	Universal Receiver Module — Simplified Signal Flow Diagram	14-1
14-2	Universal Receiver/FSK Receiver Front Panel	14-2
14-3	Universal Receiver/FSK Receiver Location of SW1 Dip switch & J3	14-8
15-1	Simplified Signal Flow Diag. for 2-Frequency Operation	15-1
15-2	Simplified Signal Flow Diag. for 3-Frequency Operation	15-2
15-3	Front Panel for 2-Frequency Directional Comparison Applications	15-4

FIGURES, Cont'd

15-4	Front Panel for 3-Frequency Directional Comparison Applications	15-5
15-5	Front Panel for 2-Frequency Phase Comparison Applications	15-5
15-6	Receiver Logic External (Rear Panel) Connections	15-6
15-7	2-Frequency Directional Comparison Functional Block Diagram (11x17)	15-7
15-8	3-Frequency Directional Comparison Functional Block Diagram (11x17)	15-8
15-9	Phase Comparison Functional Block Diagram	15-9
15-10	Receiver Logic Component Location	15-21
15-11	Receiver Logic Schematic (Sheet 1 of 3)	15-22
15-12	Receiver Logic Schematic (Sheet 2 of 3)	15-23
15-13	Receiver Logic Schematic (Sheet 3 of 3)	15-24
16-1	EM Output Module Front Panel	16-1
16-2	EM Output Component location	16-3
16-3	EM Output Schematic	16-4
17-1	Voice Adapter Module — Simplified Signal Flow Diagram	17-1
17-2	Voice Adapter Module Front Panel	17-4
17-3	Voice Adapter Module Component location	17-6
17-4	Voice Adapter Schematic (Sheet 1 of 2)	17-7
17-5	Voice Adapter Schematic (Sheet 2 of 2)	17-8
17-6	Connections for Remote Phone and External Alarm	17-9
17-7	External Alarm Circuit for Use with Module Front Panel Jack	17-9
17-8	Handset Schematic	17-10
18-1	TTU Transmitter Front Panel	18-1
18-2	Interconnecting cables for TTUs in Receiver only/Transmitter only chassis	18-5
18-3	Schematic of TTU Daughter Board (Sheet 1 of 2)	18-6
18-4	Schematic of TTU Daughter Board (Sheet 2 of 2)	18-7
18-5	Component Layout for TTU Daughter Board (Sheet 2 of 2)	18-8
18-6	Transmitter Board	18-9
18-7	TTU 2-Frequency Checkback Trip Timing Diagram	18-10
18-8	TTU 2-Frequency Real Trip Timing Diagram	18-11
18-9	TTU 3-Frequency Checkback Trip Timing Diagram	18-12

Contents – Tables

Table No.	Page No.
1-1 System Specifications	1-9
1-2 Transceiver Chassis Alarms w/CLI	1-11
1-3 Receiver Only Chassis Alarms w/CLI	1-11
1-4 Transmitter Only Chassis Alarms	1-11
1-5 Electro Mechanical Outputs	1-12
1-6 Electro Mechanical Output Timing	1-12
1-7 Keying Specifications	1-12
1-8 Transmitter Specifications	1-13
1-9 Receiver Specifications	1-13
1-10 Power Requirement Specifications	1-14
1-11 Weight and Dimension	1-14
1-12 Environmental Requirements	1-15
1-13 Altitude Dielectric Strength De-rating for Air Insulation	1-16
1-14 Altitude Correction for Maximum Temperature of Cooling Air	1-16
1-15 Voice Adapter Option Specifications	1-17
2-1 Operation of the Directional Comparison Unblocking	2-3
2-2 Operation of Underreaching Transfer Trip Schemes	2-3
2-3 TCF-10B Accessories	2-21
2-4 TCF-10B Catalog Numbers	2-22
3-1 Receiver (SW1 settings)	3-7
3-2 Receiver (SW1-1 set to the OFF position)	3-7
4-1 Recommended Test Equipment	4-1
7-1 Voltage Specifications	7-1
7-2 Voltage Specifications	7-3
7-3 Transmitter Output Levels	7-3
7-4 Transmitter LEDs	7-3
7-5 Output Frequency Shifts	7-4
7-6 Keying Module Links, LEDs, Output	7-4

TABLES, Cont'd

Table No.	Page No.
7-7 FSK Receiver (SW1-1 settings)	7-8
7-8 FSK Receiver (SW1-1 set to the OFF position)	7-8
7-9 Phase Comparison Units (Only) Testing	7-9
7-10 2-Frequency Directional Comparison Units (Only) Testing	7-10
7-11 3-Frequency Directional Comparison Units (Only) Testing	7-12
9-1 1617C38 Styles and Descriptions	9-1
10-1 1606C50 Styles and Descriptions	10-1
10-2 Truth Tables for TCF-10B Keying Module (G01 - Shift down to trip)	10-4
10-3 Truth Tables for TCF-10B Keying Module (G03 - Shift up to trip)	10-5
11-1 1610C01 /Styles and Descriptions	11-1
12-1 1606C33 Styles and Descriptions	12-1
13-1 1609C32 Styles and Description	13-1
14-1 Universal Receiver Style	14-1
14-2 Receiver System Specifications	14-3
14-3 FSK Frequency Spacing Specifications (Minimum)	14-4
14-4 Universal Receiver (SW1 settings)	14-5
14-5 Universal Receiver (SW1-1 set to the OFF position)	14-5
15-1 CF20-RXLMN-00X Styles and Descriptions	15-1
15-2 Trip Delay Switch Settings for POTT/DTT/UB 2F Applications	15-11
15-3 Trip Hold Time Switch Settings for POTT/DTT/UB 2F Applications	15-12
15-4 Guard Hold Time Switch Settings for POTT/DTT/UB 2F Applications	15-12
15-5 Unblock Time Switch Settings for POTT/DTT/UB 2F Applications	15-12
15-6 Noise Block of Unblock Switch Settings for POTT/DTT/UB 2F Applications	15-13
15-7 Guard Before Trip Switch Settings for POTT/DTT/UB 2F Applications	15-13
15-8 Low Level Delay Switch Settings for POTT/DTT/UB 2F Applications	15-13
15-9 Trip Delay Switch Settings for POTT/UB 3F Applications	15-14
15-10 Trip Hold Time Switch Settings for POTT/UB 3F Applications	15-15
15-11 Guard Hold Time Switch Settings for POTT/UB 3F Applications	15-15
15-12 Unblock Time Switch Settings for POTT/UB 3F Applications	15-15
15-13 Noise Block of Unblock Switch Settings for POTT/UB 3F Applications	15-16

TABLES, Cont'd

Table No.	Page No.
15-14 Guard Before Trip Switch Settings for POTT/UB 3F Applications	15-16
15-15 Low Level Delay Switch Settings for POTT/UB 3F Applications	15-16
15-16 Trip Delay Switch Settings for DTT 3F Applications	15-17
15-17 Trip Hold Time Switch Settings for DTT 3F Applications	15-18
15-18 Guard Hold Time Switch Settings for DTT 3F Applications	15-18
15-19 Checkback Trip Output	15-18
15-20 Polarity Switch Settings for Phase Comparison Applications	15-19
15-21 SPCU/SKBU Switch Settings for Phase Comparison Applications	15-19
16-1 1606C53 Styles and Descriptions	16-1
16-2 Output Options	16-1
17-1 C020-VADMN Styles and Descriptions	17-1
17-2 Voice Adapter Module Electrical Characteristics	17-3
17-3 DIP Switch Setting Functions	17-5
17-4 Default (Normal) Settings for TCF-10B Operation	17-5
18-1 1610C01 Styles and Descriptions	18-1
18-2 TTU Jumpers	18-4

Trademarks

All terms mentioned in this book that are known to be trademarks or service marks are listed below. In addition, terms suspected of being trademarks or service marks have been appropriately capitalized. Pulsar Technologies, Inc. cannot attest to the accuracy of this information. Use of a term in this book should not be regarded as affecting the validity of any trademark or service mark.

This publication includes fonts and/or images from CorelDRAW which are protected by the copyright laws of the U.S., Canada and elsewhere. Used under license.

IBM and PC are registered trademarks of the International Business Machines Corporation.

Chapter 1. Product Description

1.1 Standard Nomenclature

The standard nomenclature for PULSAR carrier protection equipment is as follows:

Cabinet – contains fixed-racks, swing-racks, or open racks

Rack – contains one or more chassis (e.g., the TCF-10B)

Chassis – contains several printed circuit boards, called modules (e.g., Transmitter or Receiver)

Module – contains a number of functional circuits (e.g., Oscillator or Synthesizer)

Circuit – a complete function on a printed circuit board

1.2 TCF-10B Chassis

The TCF-10B chassis specifications (see Figure 3-3) include standard dimensions of:

Height – 5.25” (133.35 mm), requiring 3 rack units, each measuring 1.75” (44.45 mm)

Width – 19.00” (482.6 mm)

Depth – 13.50” (342.9 mm)

Each chassis is notched for mounting in a standard relay rack.

1.3 TCF-10B Modules

The TCF-10B circuitry for the standard modules and the optional Voice Adapter, Electro-Mechanical Output and Trip Test Unit modules is shown on the Functional Block Diagram in Chapter 6. Circuit descriptions, with schematic diagrams or block diagrams for each module, are shown in Chapters 9 through 18, along with sub numbers indicating the current revisions for each module, as follows:

<u>Chapter</u>	<u>Module</u>	<u>Schematic</u>
9.	Power Supply	1617C39-6
10.	Keying	1606C50-9
11.	Transmitter	C030-TXMMN-2
12.	10W PA	1606C33-21
13.	RF Interface	1609C32-9
14.	Receiver	C030-RXVMN-7
15.	Receiver Logic	CF30-RXLMN-6
16.	EM Output Module	1606C53-7
17.	Voice Adapter	C030-VADMN-4
18.	TTU – Trip Test Unit	1614C25-3

1.4 TCF-10B Configurations

There are three different configurations (or sets) for the TCF-10B:

- 1) Transceiver (Transmitter with Receiver) set
- 2) Transmitter (only) set
- 3) Receiver (only) set

NOTE

See Chapter 2, Applications and Ordering Information, for ordering information.
See Chapter 3, Installation, for a summary of jumper controls.

1.4.1 Transceiver Set

The Transceiver set (see Figure 1-1) includes the following modules:

- Power Supply
- Keying
- Transmitter
- Receiver Logic
- RF Interface
- Universal Receiver
- Trip Test Unit (Optional)
- EM Output (Optional)
- Voice Adapter (Optional)
- 10W PA

1.4.2 Transmitter (only) Set

The Transmitter (only) set (see Figure 1-2) includes the following modules:

- Power Supply
- Keying
- Transmitter
- 10W PA
- RF Interface
- Trip Test Unit (Optional)

1.4.3 Receiver (only) Set

The Receiver (only) set (see Figure 1-3) includes the following modules:

- Power Supply
- RF Interface
- Receiver Logic
- EM Output (Optional)
- Trip Test Unit (Optional)
- Universal Receiver

1.5 TCF–10B Module Front Panels

The front (control) panel for each module could include the following types of controls:

- Switches
- LEDs
- Meter
- Potentiometers
- Test Jacks
- Push-buttons

All front panels are the same for all TCF–10B versions, with the exception of the Receiver Logic panel. There are three different Receiver Logic front panels for the TCF–10B, based on the specific application.

1.5.1 2-Frequency, Transfer Trip/Unblock Receiver Logic Front Panel

This panel is shown in Figure 1-4.

Four LEDs provide signal indication for two-frequency, transfer trip/unblock applications:

- Good Channel
- Checkback Trip
- Trip
- Guard

1.5.2 3-Frequency, Transfer Trip/Unblock Receiver Logic Front Panel

This panel is shown in Figure 1-5.

Five LEDs provide signal indication for three-frequency, transfer trip/unblock applications:

- Good Channel
- Checkback Trip
- UB/POTT Trip
- DTT Trip
- Guard

1.5.3 2-Frequency, Phase Comparison Receiver Logic Front Panel

This panel is shown in Figure 1-6.

Three LEDs provide signal indication for two-frequency, Phase Comparison applications:

- Good Channel
- Trip Positive
- Trip Negative

1.6 TCF-10B Printed Circuit Boards (PCBs)

A module's printed circuit board (PCB) could include the following types of controls:

- Switches
- Jumpers
- Variable Capacitors
- Potentiometers
- Test Points
- Impedance Matching Jumpers

1.7 TCF-10B Rear Panel (“Mother Board”)

(See Chapter 3, Section 3.5 for a description of the Rear Panel.)

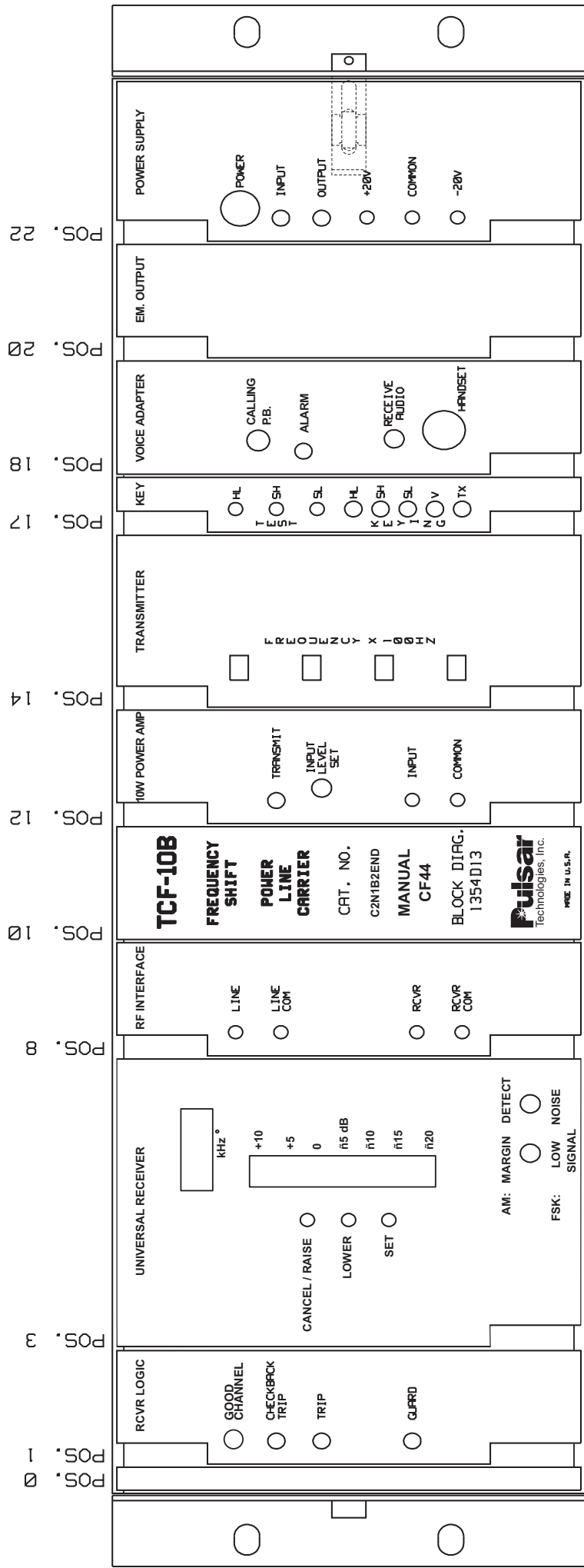

POS. 0
POS. 1
POS. 3
POS. 8
POS. 10
POS. 12
POS. 14
POS. 17
POS. 18
POS. 20
POS. 22

Figure 1-1. TCF-10B Transceiver Set (1355D19).

Figure 1-2. TCF-10B Transmitter (only) Set (1355D19).

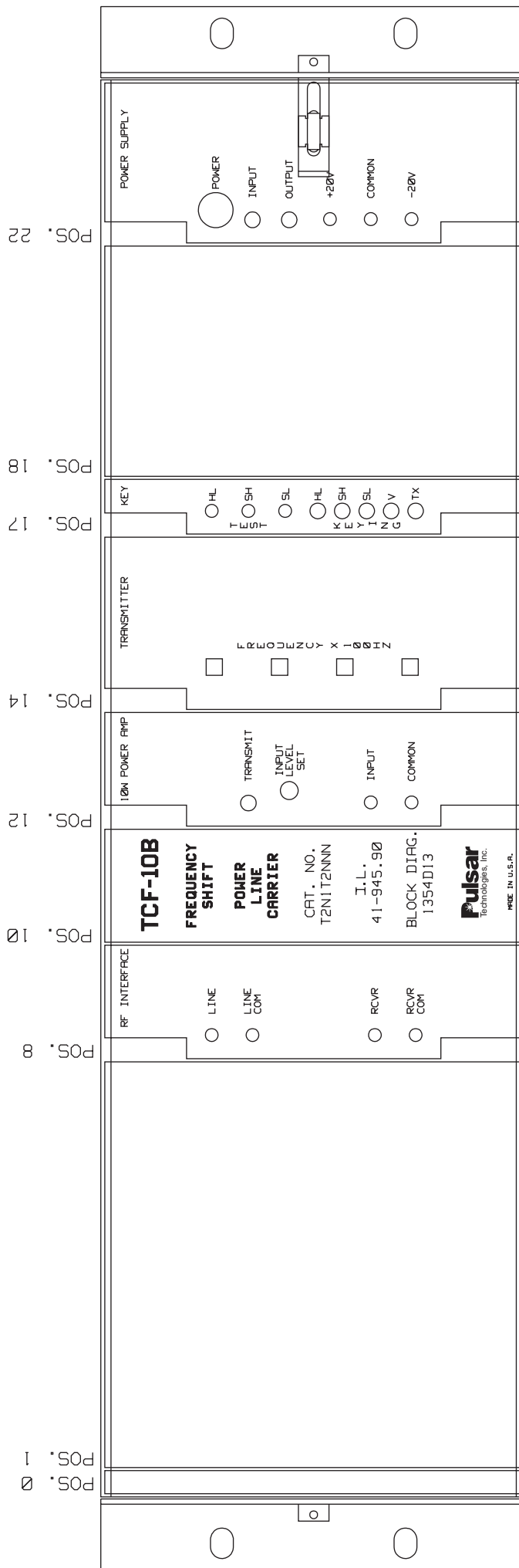

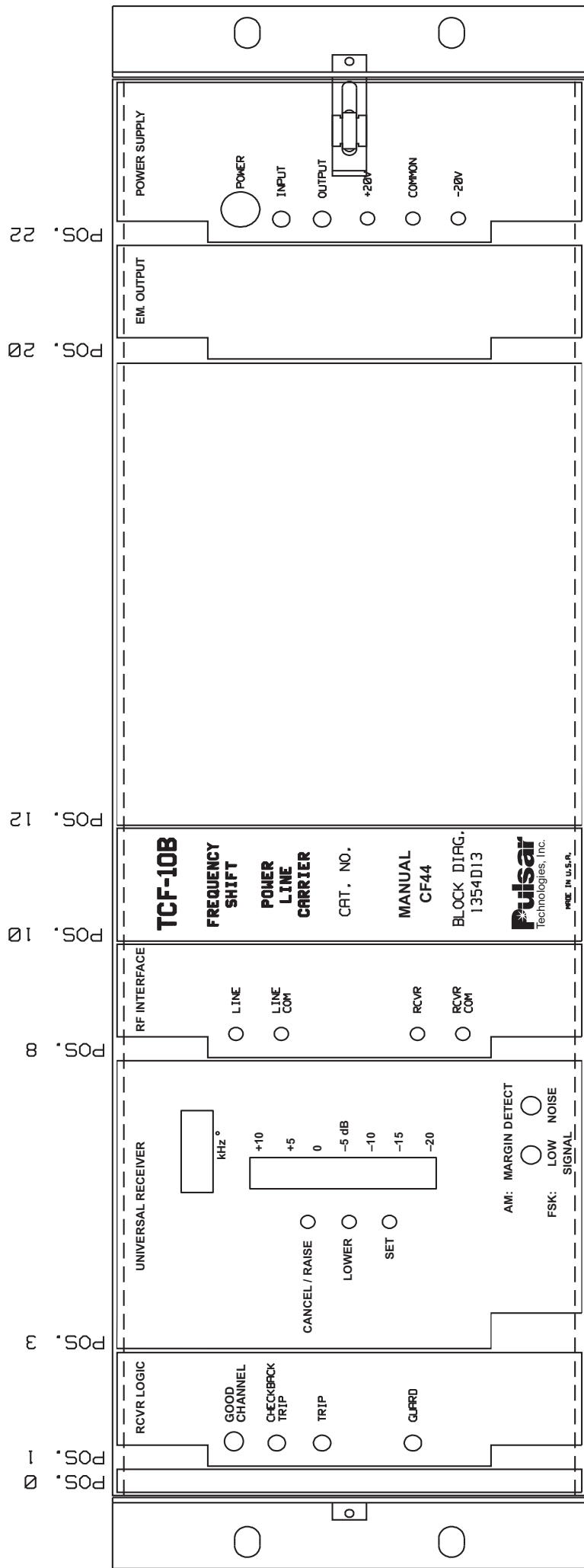

Figure 1-3. TCF-10B Receiver (Only) Set (1355D19).



Figure 1-4.
Front Panel for 2-Frequency,
Transfer Trip or Unblock
Applications.



Figure 1-5.
Front Panel for 3-Frequency,
Transfer Trip and Unblock
Applications.

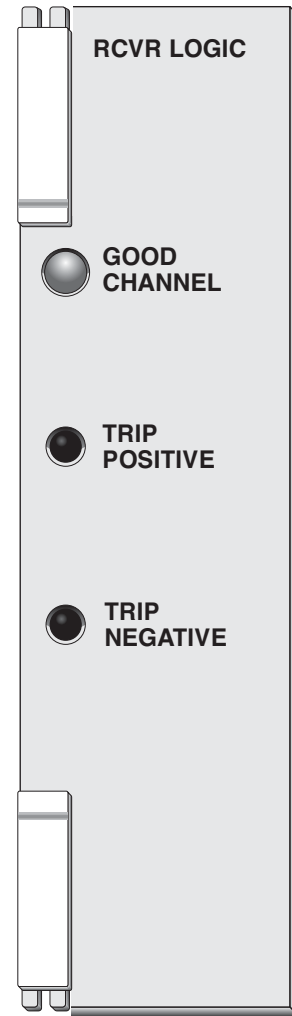

Figure 1-6.
Front Panel for 2-Frequency,
Phase Comparison
Applications.

1.8 Specifications

The TCF-10B meets or exceeds all applicable ANSI/IEEE standards as follows:

*Proposed American National Standard
Requirements for Single Function Power-Line Carrier
Transmitter/Receiver Equipment
(ANS C93.5)*

1

1.8.1 System

Table 1-1 lists the system specifications for the TCF-10B.

Table 1-1. System Specifications.

Frequency Range	30–535 kHz in 0.5 kHz (500 Hz) steps; transmitter selection in 100 Hz steps
4-Wire Receiver Input Impedance	5,000 Ω (1,000 Ω when strapped for high sensitivity)
RF Input Impedance	Nominal unbalanced 50 Ω , 75 Ω or 100 Ω
Output Power	10 W (max), 0.1 W (min), 50 or 100 W (with optional external amplifier)
Modulation Type	Frequency-Shift Keyed (FSK); strappable for either two- or three-frequency operation
Frequency Shift	Narrow Shift (\pm 100 Hz) Wide Shift (\pm 250 Hz) Extra Wide Shift (\pm 500 Hz)
Nominal Receiver Bandwidths	Narrow Band (380 Hz at 3 dB points) Wide Band (800 Hz at 3 dB points) Extra Wide Band (1,600 Hz at 3 dB points)
In-Band SNR	w/o voice 13 dB w/voice 30 dB

Receive Sensitivity	
Standard Setting	High Setting
22.5 mV (min) to 70 V (max)	5 mV (min) to 17 V (max)
-20 dBm to +50 dBm @ 50 Ω	-35 dBm to +38 dBm @ 50 Ω

Table 1-1. System Specifications (Cont'd).

Channel Speed Receiver set for 15 dB margin:	
Narrow Band	7.5 ms*
Wide Band	5.9 ms*
Extra Wide Band	4.7 ms*

II Minimum Frequency Spacing: (For channels without voice; depends on application.)		
Narrow Band	Unblock or Transfer Trip	(1-way, 500 Hz) (2-way, 1,000 Hz)†
Wide Band (Narrow or Wide Shift)	Unblock or Transfer Trip	(1-way, 1,000 Hz) (2-way, 2,000 Hz)†
	Phase Comparison (SKBU-2A) (60 Hz sq. wave keying)	(1-way, 1,500 Hz) (2-way, 3,000 Hz)†
	Phase Comparison (SPCU-1A) (60 Hz 3ms pulse keying)	(1-way, 2,000 Hz) (2-way, 4,000 Hz)†
Extra Wide Band	Unblock or Transfer Trip	(1-way, 2,000 Hz) (2-way, 4,000 Hz)†
	Phase Comparison (SKBU-2A) (60 Hz sq. wave keying)	(1-way, 2,000 Hz) (2-way, 4,000 Hz)†
	Phase Comparison (SPCU-1A) (60 Hz 3ms pulse keying)	(1-way, 2,000 Hz) (2-way, 4,000 Hz)†

All Voice Applications (See Section 1.8.10)	Minimum Channel Spacing	(2-way, 4,000 Hz)
---	-------------------------	-------------------

1-way represents transmitter to transmitter or receiver to receiver
2-way represents transmitter to receiver

* Times do not include logic trip delay or relay operate times.

† An external hybrid or other device offering at least 20 dB rejection of the adjacent channel must be used in the application.

1.8.2 Alarm & Level Options

This section provides three tables depicting the alarm and level options, broken down as follows:

- Transceiver Chassis Alarms w/CLI
- Receiver Only Chassis Alarms w/CLI
- Transmitter Only Chassis Alarms

Each alarm contact is rated 10 VA (Form A or B).

Table 1–2. Transceiver Chassis Alarms w/CLI.

Power Supply Module	Loss of dc power
Keying Module	Shift High/Shift Low (for guard or trip)
10W PA Module	Loss of Transmitter RF power output
Universal Receiver Module	Low-Signal; RF Signal Received; CLI output for External CLI Meter (-20 dB to +10 dB; 0–100 μ A)

Table 1–3. Receiver Only Chassis Alarms w/CLI.

Power Supply Module	Loss of dc power
Universal Receiver Module	Low-Signal; RF Signal Received; CLI output for External CLI Meter (-20 dB to +10 dB; 0–100 μ A)

Table 1–4. Transmitter Only Chassis Alarms.

Power Supply Module	Loss of dc power
Keying Module	Shift High/Shift Low
10W PA Module	Loss of Transmitter RF power output

1.8.3 Electro-Mechanical Outputs

This section provides two tables depicting the Electro-Mechanical Output Module's specifications, broken down as follows:

- Electro Mechanical Outputs
- Electro Mechanical Output Timing

Table 1-5. Electro Mechanical Outputs.

Contacts	Output
Six (6) contacts for Guard or Trip 1 or Trip 2	Make and carry rated 30 A for 1 second; 10 A continuous capability break 50 W resistive or 25 W with L/R = .045 seconds

Table 1-6. Electro Mechanical Output Timing.

Typical Operate Time		Typical Release Time	
NO Contact Closes	NC Contact Opens	NO Contact Opens	NC Contact Closes
3.0 ms 3.0 ms bounce	2.0 ms	2.8 ms	3.8 ms 4.0 bounce

1.8.4 Keying

Table 1-7 shows the TCF-10B keying specifications.

Table 1-7. Keying Specifications.

Five (5) optically-isolated keying inputs, strappable at 15/20, 48, 125, 250 Vdc	<ol style="list-style-type: none"> 1) Unblock or Phase Comparison 2) Direct Transfer Trip 3) Power Boost or 52b Keying 4) RF Power On/Off 5) Voice Adapter
Maximum input keying burden	10 mA
Manual keying	Recessed push-button switches for high- and low-frequency keying, and power boost

1.8.5 Transmitter

Table 1-8 shows the TCF-10B transmitter specifications.

Table 1-8. Transmitter Specifications.

Harmonic and Spurious Output	55 dB below 10 W
Output Variation	± 1 dB over temperature and voltage range
Frequency Stability: Narrow Shift Wide Shift Extra Wide Shift	± 10 Hz

1.8.6 Receiver

Table 1-9 shows the TCF-10B receiver specifications.

Table 1-9. Receiver Specifications.

Frequency Stability: Narrow Band, Narrow Shift Wide Band, Narrow Shift Wide Band, Wide Shift Extra Wide Band, Extra Wide Shift	± 10 Hz
Five 1 A isolated outputs for 15/20 Vdc or station battery circuits	<ol style="list-style-type: none"> 1) Unblock or Trip or Trip-Positive 2) Low-Level or Low Signal 3) Guard or Trip-Negative 4) Noise 5) Checkback Trip (not used with Phase Comparison)

NOTE

An optional 20 V Power Supply is available for use with some Phase Comparison and some Directional Comparison systems. For further information, please see TCF-10B Accessories under Chapter 2, Applications.

1.8.7 Power Requirements

Table 1-10 shows the TCF-10B power requirement specifications.

Table 1-10. Power Requirement Specifications.

Transceiver		Supply Current (Amps) At Nominal Voltage		
Nominal Battery Voltage	Permissible Voltage Range	Receive/Standby	1 Watt Transmit	10 Watt Transmit
48/60 Vdc	38–70 Vdc	0.630	0.940	1.600
110/125 Vdc	88–140 Vdc	0.240	0.360	0.600
220/250 Vdc	176–280 Vdc	0.120	0.180	0.300

Permissible ripple on incoming Vdc	5%
Maximum allowable frequency of ripple	120 Hz
Carrier frequency on dc input leads when transmitting 10 W	20 mV (max)

1.8.8 Weights and Dimensions

Table 1-11 shows the TCF-10B weight and dimension specifications.

Table 1-11. Weight and Dimension Specifications.

Equipment	Net Weight		Height		Width		Depth		Rack Space
	lbs	Kg	inches	mm	inches	mm	inches	mm	
Transceiver	21	9.53	5.25	133.4	19.00	482.6	13.50	342.9	3 RU
Transmitter	14	6.35	5.25	133.4	19.00	482.6	13.50	342.9	3 RU
Receiver	12	5.45	5.25	133.4	19.00	482.6	13.50	342.9	3 RU

1.8.9 Environmental Requirements

This section provides three tables depicting the environmental requirement specifications, broken down as follows:

- Environmental Requirements
- Altitude Dielectric Strength De-Rating for Air Insulation (Table 1-13)
- Altitude Correction For Maximum Temperature Of Cooling Air (ANS C93.5) (Table 1-14)

1

Table 1–12. Environmental Requirements.

Ambient temperature range	-20 to + 60 deg. C (derated per Table 1-14) of air-contacting equipment
Relative humidity	Up to 95% (non-condensing) at 40 deg. C (for 96 hours cumulative)
Altitude	Up to 1,500 m (without derating) Up to 6,000 m (using Table 1-13 and Table 1-14)
Transient withstand capability	All external user interfaces meet SWC specifications of ANS C37.90.1 (1989)
1-minute withstand	Only isolated inputs and outputs, and all alarms: 2,500 Vdc from each terminal to ground, derated per Table 1-13.
Center conductor of coaxial	3,000 Vdc impulse level, cable to ground using 1.2 x 50 cable to ground msec impulse
Electro-Magnetic Interface Capability	IEEE Standard ANS C37.90.2

Table 1-13.
Altitude Dielectric Strength
De-Rating for Air Insulation

Altitude (Meters)	Correction Factor
1,500	1.00
1,800	0.97
2,100	0.94
2,400	0.91
2,700	0.87
3,000	0.83
3,600	0.79
4,200	0.74
4,800	0.69
5,400	0.64
6,000	0.59

Table 1-14.
Altitude Correction For Maximum
Temperature Of Cooling Air (ANS C93.5)

Altitude (Meters)		Temperatures (Degrees C)		
		Short-Time	Long-Time	Difference From Usual
Usual	1,500	55	40	—
Unusual	2,000	53	38	2
Unusual	3,000	48	33	7
Unusual	4,000	43	28	12

1.8.10 Voice Adapter Option

Table 1-15 shows the specifications for the TCF-10B Voice Adapter option.

Table 1-15. Voice Adapter Option Specifications.

Modulation	Amplitude Modulation with compander
Transmission	Full-Duplex
Frequency Response	380 Hz to 2,000 Hz
Signaling	370 Hz AM with signaling push-button

If the Voice Adapter option is included, it will have an independent receiver of 4 kHz bandwidth, regardless of whether the system is operating at 1,600 Hz (extra wide band), 800 Hz (wide band), or 380 Hz (narrow band).

Chapter 2. Applications and Ordering Information

2.1 Protective Relay Applications Using Frequency Shift Carriers

The TCF-10B carrier set is particularly suitable for the following types of protective relay systems:

- Directional Comparison Unblocking
- Permissive Overreaching Transfer Trip (POTT)
- Permissive Underreaching Transfer Trip (PUTT)
- Dual Phase Comparison Unblocking
- Segregated Phase Comparison Unblocking
- Direct Transfer Trip

2.1.1 Directional Comparison Unblocking

The Directional Comparison Unblocking systems transmit a continuous blocking signal, except during internal faults. The channel is generally a frequency-shift keyed (FSK) power line carrier. For an internal fault, the FSK transmitter is shifted to the “unblock” frequency. The transmitted power in many applications is normally 1 W, boosted to 10 W during unblock operation.

The frequency-shift channel is monitored continuously to prevent tripping when a loss of channel occurs. The carrier receiver logic is shown in

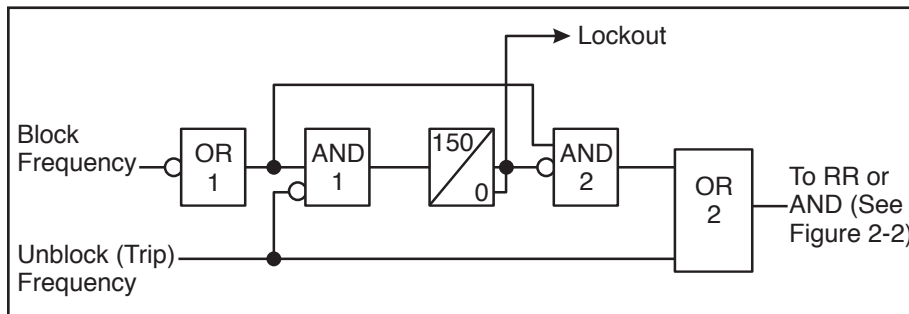

Figure 2-1. Simplified Unblock Receiver Logic.

Figure 2-1. Under normal conditions, a block frequency is transmitted and OR-1 has no input. Because AND-1 and AND-2 are not satisfied, OR-2 is not energized. For an internal fault, the block frequency is removed. Assuming that the unblock signal is shorted out by the fault, OR-1 provides a direct input to AND-2 to satisfy its input requirements for 150 ms. AND-2 inputs to OR-2 to operate the RR or to provide input to the AND shown in Figure 2-3. Without an unblock signal, 150 ms is allowed for tripping. After this period, lock out is initiated as one of the inputs to AND-2 is removed. This resets the RR or removes the input to AND. If the unblock signal is received, it inputs directly to OR-2 to energize the RR or to provide input to AND. The unblock signal also removes an input to AND-1 to stop the timer. A channel failure (no block or unblock signal) provides input to AND-1 and, after 150ms, locks out the relaying and triggers an alarm. The operation of the scheme shown in Figure 2-3 is given in Table 2-1 for external and internal faults. The phase and ground trip fault detectors at both stations must operate for all internal faults; that is, they must overreach the remote bus.

The dependability and security of Directional Comparison Unblocking systems make them the most attractive of the protective schemes for transmission lines using power line carrier channels. Over-tripping is avoided by continuous blocking and continuous channel monitoring.

Only an external fault within 150 ms after channel failure can result in over-tripping.

The scheme is most appropriate for two-terminal lines, but is applicable to multi-terminal lines. Separate channels are required between each terminal

and the remote terminal(s). A sample schematic is shown in Figure 2-2.

You may conserve frequency spectrum by using a narrow band frequency shift carrier, but at the expense of channel speed (see Chapter 1, Specifications).

Another consideration is an open breaker situation. When the remote breaker is open for an extended period of time, the relay system must be able to trip. The remote relay system sends a trip signal when detecting a remote open breaker. If this remote signal is received for 1,000 ms (1 sec) or longer, the carrier receiver logic interprets this as an open breaker and allows the local end to trip.

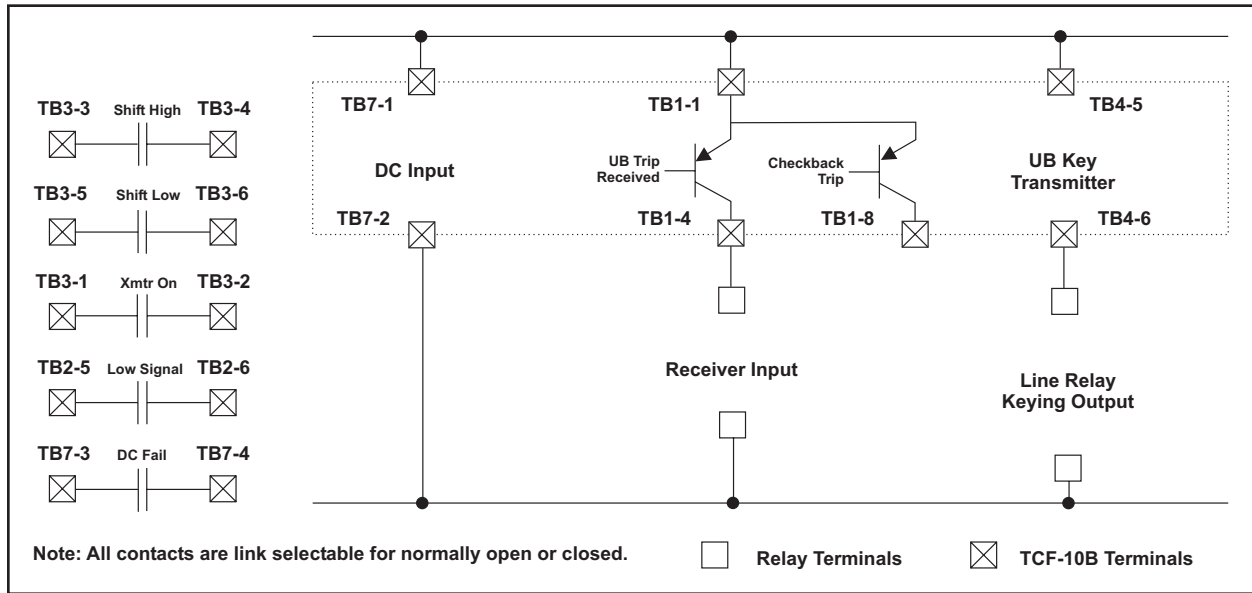

Figure 2-2. TCF-10B Transceiver Unit Connections, 2 Freq. set (Directional Comparison Unblock Relaying) Typical Catalog: C2M1B2SND

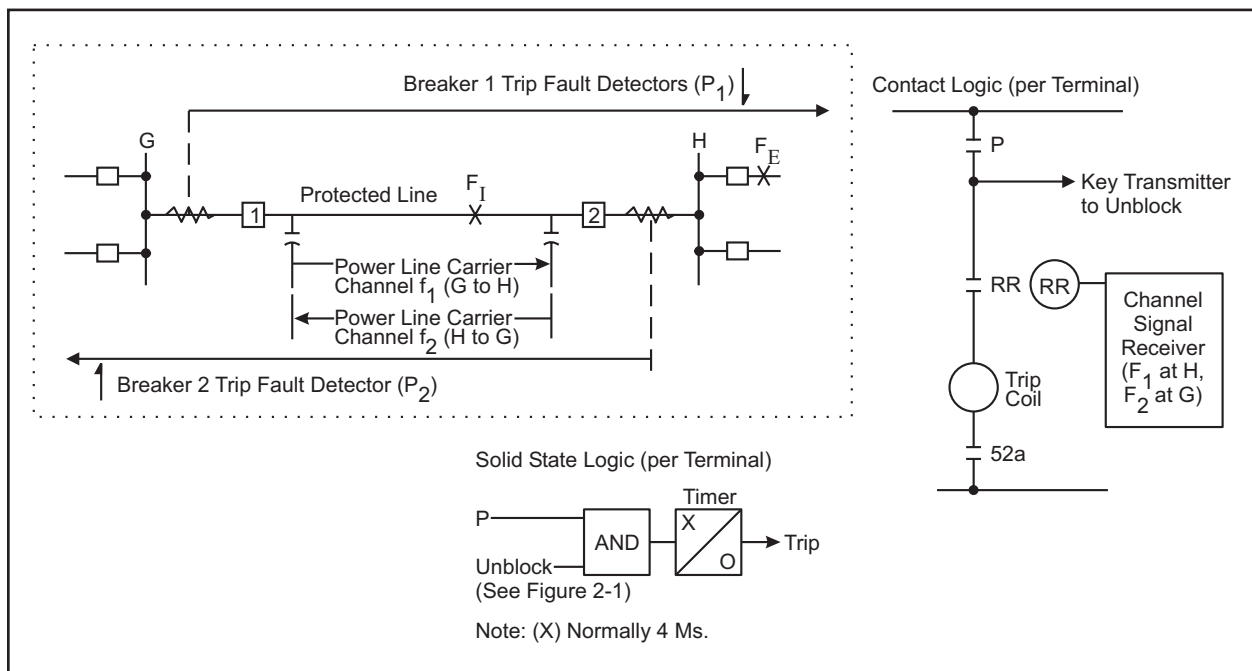

Figure 2-3. Basic Logic Diagrams for Directional Comparison Unblocking.

Table 2–1. Operation of the Directional Comparison Unblocking Scheme.

SCHEME FOR EXTERNAL AND INTERNAL FAULTS		
Type of Fault	Events at Station G	Events at Station H
External (F_E)	<p>P_1 operates.</p> <p>f_1 channel shifts to unblock.</p> <p>f_2 channel continues to block.</p> <p>No trip.</p>	<p>P_2 does not see fault.</p> <p>Loss of block and/or receipt of unblock (f_1) operates RR or inputs AND.</p> <p>No trip.</p>
Internal (F_I)	<p>P_1 operates.</p> <p>f_1 channel to unblock.</p> <p>Loss of block and/ or receipt of unblock (f_2) operates RR or inputs AND.</p> <p>Trip.</p>	<p>P_2 operates.</p> <p>f_2 channel shifts to unblock.</p> <p>Loss of block and/or receipt of unblock (f_1) operates RR or inputs AND.</p> <p>Trip.</p>

Table 2–2. Operation of the Underreaching Transfer Trip Scheme.

SCHEME FOR EXTERNAL AND INTERNAL FAULTS		
Type of Fault	Events at Station G	Events at Station H
External (F_E)	<p>P_1 does not operate.</p> <p>No channel signal sent to H.</p> <p>No trip.</p>	<p>P_2 does not operate.</p> <p>No channel signal sent to G.</p> <p>No trip.</p>
Internal (F_I) (Fault near station H)	<p>P_1 does not operate.</p> <p>No channel signal sent to H.</p> <p>* (FD_1 operates).</p> <p>Transfer-trip (f_2) from station H operates RR or inputs to AND (or OR if non-permissive).</p> <p>Trip.</p>	<p>P_2 operates and trips directly.</p> <p>Transfer-trip signal keyed to station G.</p> <p>* (FD_2 operates).</p> <p>Trip.</p>

* Omitted in non-permissive systems.

whenever the local relays detect a fault.

2.1.2 Permissive Overreaching Transfer Trip Systems

Overreaching transfer trip systems require a channel signal to trip, and are used with a frequency-shift audio tone, modulated on a communication channel (e.g., public or private telephone lines). These systems are generally not used with power line carriers. There are, however, successful applications of power-line carrier on POTT schemes where parallel lines allow for cross-coupling of the carrier signal.

2.1.3 Permissive and Non-Permissive Underreaching Transfer Trip Systems

For overreaching systems, the directional phase and ground trip fault detectors (P) must be set to overlap within the transmission line and not overreach any terminals (see Figure 2-4).

That is, at least one trip fault detector (P) must operate for all internal faults, and none should operate for any external fault. In practice, distance relays are normally required for both ground faults and phase faults, although directional instantaneous ground-overcurrent relays might meet these requirements in some cases.

Though it is the least complex, the non-permissive system is rarely used because of the high potential for false outputs from the channel,

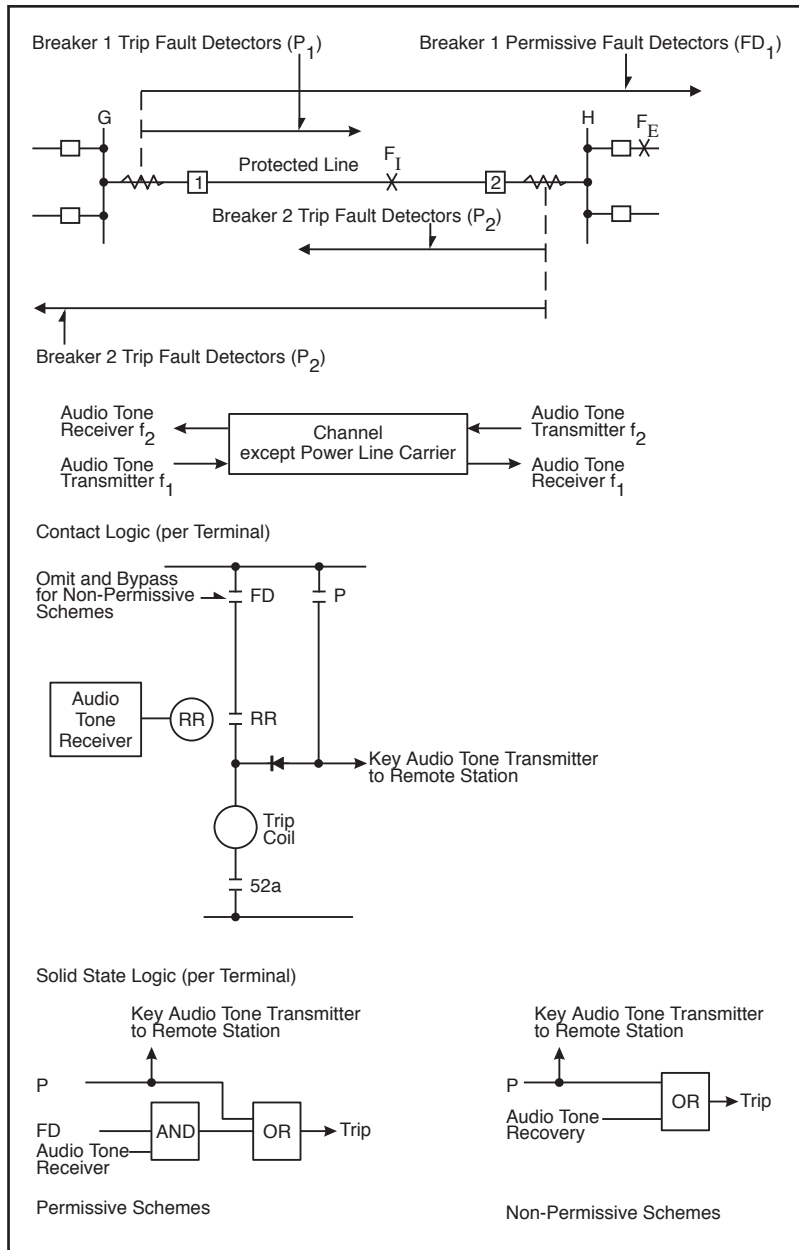

Figure 2-4. Basic Logic Diagrams for Underreaching Transfer Trip Systems.

which would cause incorrect tripping. If a non-permissive system is used, the channel considerations should be as described later for direct trip systems. The system is made permissive by the additional set of phase and ground overreaching fault detectors (FD), which must operate for all internal faults (see Figure 2-4).

Operation of the underreaching transfer trip scheme shown in Figure 2-4 is described in Table 2-2 for external and internal faults. Because the trip fault detectors (P) do not operate for external faults, underreaching transfer trip systems do not require external

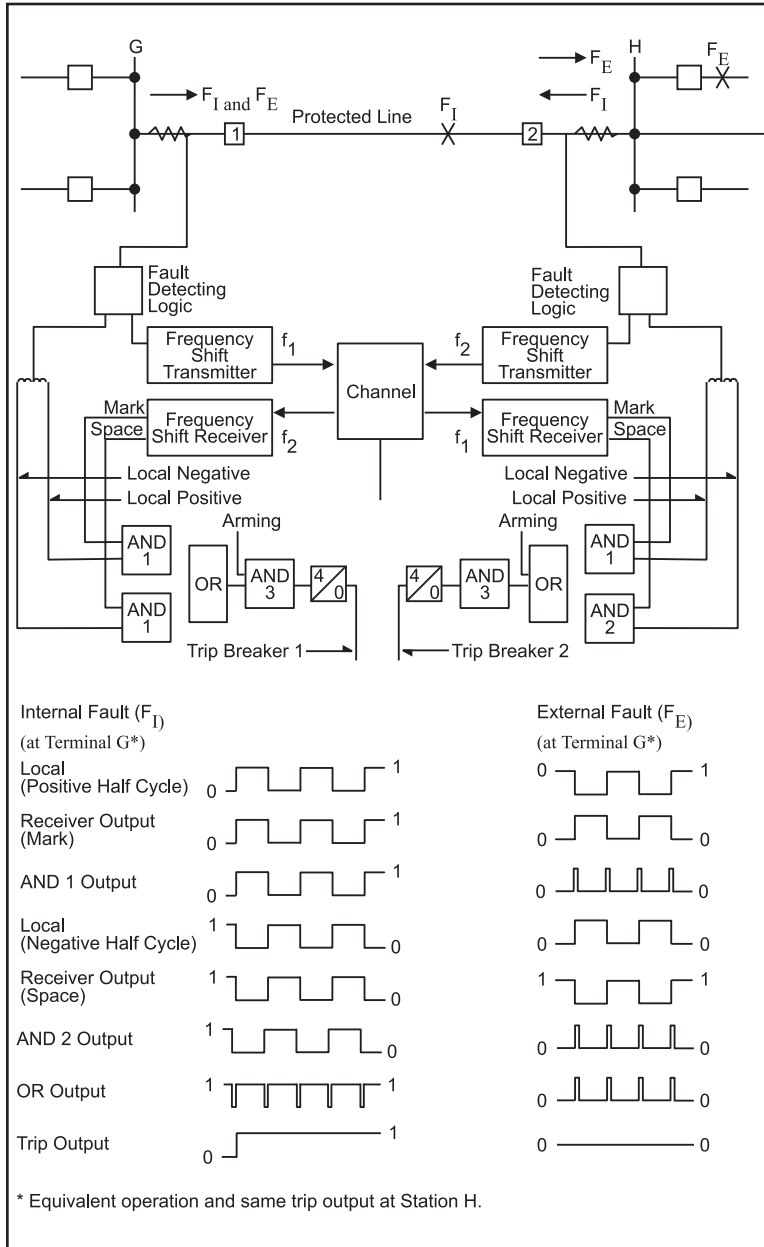

Figure 2-5. Basic Operation of the Dual Phase Comparison Pilot Relaying System.

fault-clearing coordination circuits (transient blocking) and are, therefore, inherently simpler than any of the other schemes. You obtain maximum security if you use additional permissive fault detectors. These schemes also provide minimum operating times for many faults that are tripped directly, without using the channel.

2.1.4 Dual Phase Comparison Unblocking Systems

Dual comparison systems require a duplex channel: one frequency for each line terminal. The TCF-10B frequency-shift channel equipment is available for this purpose; normally used in an unblocking system. Continuous channel monitoring is also provided, because either a trip positive or trip negative carrier signal is always transmitted.

The transmitter is keyed to its trip positive frequency when the square wave from the filter goes positive, and is keyed to its trip negative frequency when the square wave is at zero. There are two outputs at the receiver: the trip positive output is a square wave that goes positive when a trip positive frequency is received; the trip negative output goes positive when a trip negative frequency is received.

The basic operation of the Dual Phase Comparison system is shown in Figure 2-5. For internal faults, the single phase outputs of the sequence current networks are essentially in phase, although such output represents currents 180° apart in the power system. The network output goes through a squaring amplifier that keys the frequency shift transmitter. An adjustable delay circuit delays the local square wave by a time equal to the channel delay time.

The network output is then used to develop two complementary square waves. One wave, which has a positive state during the positive half-cycle of the sequence

current network, is compared with the receiver's trip positive output. The other wave, which has positive output during the negative half-cycle of the sequence current network, is compared to the receiver's trip neg. output in a second comparison circuit.

On internal faults, the positive half-cycle of the local square wave lines up with the received trip positive output to provide an AND-1 output (see Figure 2-5). On the negative half-cycle, this local square wave lines up with the received trip negative output to provide an AND-2 output. If an arming signal is received (FD₂ and/or 21P) and either AND-1 or AND-2 output exists for 4ms, an input to the trip flip flop initiates breaker tripping. The same operation occurs at both terminals, tripping breakers 1 and 2 simultaneously on either half-cycle of fault current.

For tripping, both the trip positive and trip negative frequencies must be transmitted through the internal fault via power line carrier channels. If these frequencies are not received, the receiver detects a loss of channel and clamps both outputs to a continuous positive state. This loss of channel clamp enables both comparison circuits, allowing the system to trip on the local square wave input only. After 150ms, the system output clamps these to the zero state. At this point, the system cannot trip and is locked out. An alarm indicates loss of channel.

For external faults, the reversal of current at one end shifts the square waves essentially 180°. As a result, neither AND-1 nor AND-2 has the sustained output required to operate the 4ms timer (see Figure 2-5). No trip occurs at either line terminal.

2.1.5 Segregated Phase Comparison System

The Segregated Phase Comparison system has been developed to improve pilot relay protection, particularly for the long EHV series capacitor-compensated transmission lines. Long EHV series capacitor-compensated lines are a source of significant transients during the fault period. Under these circumstances, sequence current networks designed to operate at normal system

frequency may present a problem. The experience with these Phase Comparison systems has, however, been remarkably good. Directional Comparison systems, on the other hand, are subject to mis-operation on series capacitor-compensated lines, particularly if the capacitor gaps do not short the capacitors on faults. Segregated phase comparison systems, which are current-only, are independent of the following phenomena:

- Power system frequency and wave form
- Effects of impedance unbalance between the power system phase circuits.
- Maximum load/minimum fault current margin.

The segregated phase comparison system can be divided into two types: a two-subsystem scheme and a three-subsystem scheme. In the two-subsystem scheme, one subsystem operates from delta current ($I_a - I_b$) for all multi-phase faults, and a ground ($3I_0$) current subsystem operates for all ground faults. The three-subsystem scheme has a subsystem for each phase (I_a , I_b , and I_c). Each subsystem consists of one channel (TCF-10B) and one Phase Comparison relay.

Both segregated Phase Comparison systems incorporate "offset keying," enabling them to trip for internal high-resistance ground faults and internal faults with outfeed at one terminal. No other system can clear these types of faults without extra logic or channels. On a 500 kV line with a 2,000:5 current transformer ratio, for example, the three-subsystem scheme will operate for ground-fault resistances up to about 100 Ω primary impedance. Under the same conditions, the two-subsystem scheme will operate up to about 200 Ω primary fault resistance.

The two-subsystem package is suitable for all applications except single-pole tripping, where the three-subsystem package must be applied. The basic operation of the scheme is illustrated in Figure 2-6. Each current is fed through a non-inductive resistor, supplying a voltage output to the squaring amplifier (SA) that is exactly proportional to the primary currents. The output of these amplifiers is used to key the individual channels and, through the local delay timers (LDT), to

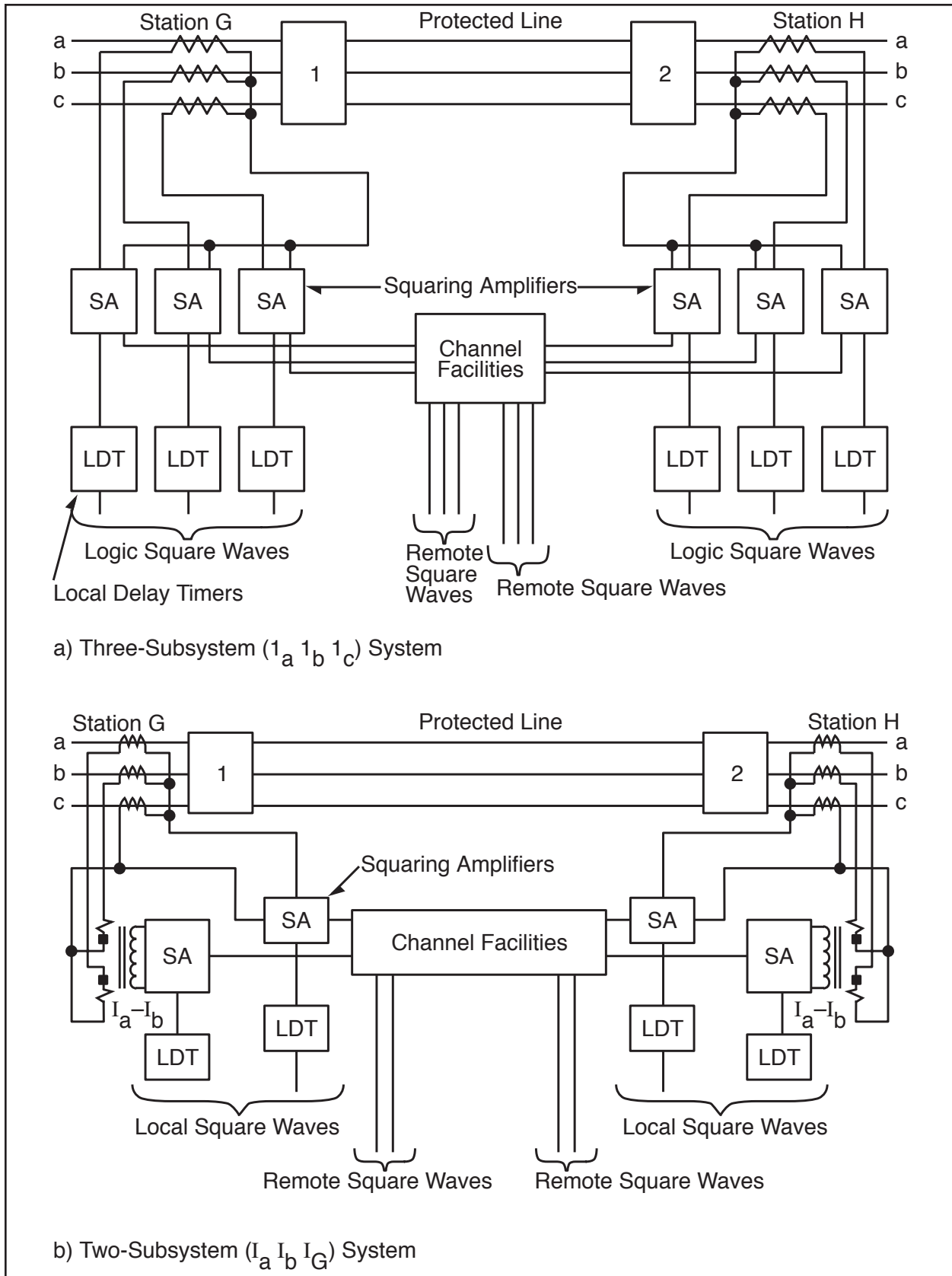

Figure 2-6. Basic Segregated Phase Comparison Systems.

provide the local square waves for comparison. The timers are adjustable between 2 and 20ms to compensate for the delay time of the channel. This digital delay circuit translates the pulse train independently of the pulse width ratio, in contrast to the ac phase angle shift used in the other systems. The ac phase shift delay uses frequency-dependent components, which are accurate only at system frequency and can “ring” during transient conditions.

The square wave comparison is made independently for each current in the separate subsystems. Separate channels are required for each of the subsystems. One of the comparison circuits is shown in simplified form in Figure 2-7. In this dual comparison circuit, AND-P is used for the positive half-cycles and AND-N for the negative half-cycles. As shown in Figure 2-7, the received positive square wave corresponds to a “1” input to AND-P, and the received negative square wave to a “0” input, negated to “1”, into AND-N. Except for this variation, operation is as shown by the square wave blocks in the lower half of Figure 2-5.

To generate the local and keying square waves, conventional phase comparison systems use thresholds equivalent to (or very near) the zero axis. As a result, an internal fault with outfeed looks like an external fault to those systems (see Figure 2-8). The offset keying technique permits the relay system to trip for internal faults with outfeed current out at one terminal. While the outfeed condition is very unusual, it presents difficult problems to the great majority of pilot relaying systems when it does occur. Outfeed can occur in any of the following cases:

- Series-capacitor-compensated parallel lines.
- Weak-feed or zero-feed applications, particularly with heavy through load.
- Some multi-terminal applications.
- Series-compensated (line-end compensation) line with a source inductive reactance smaller than series capacitor reactance.

- Some single-line-to-ground faults, occurring simultaneously with an open conductor, where the fault is on one side of the open conductor.
- Some single-line-to-ground faults with high fault resistance and heavy through load (such conditions can cause outfeed only in the faulted phase current, not in the ground subsystem).

The offset keying technique allows the relay system to work like a true current differential scheme. The scheme takes advantage of the fact that, for the outfeed condition, the current into the line is greater in magnitude than the current out of the line for the internal fault.

This relationship is illustrated in Figure 2-8, where I_G equals I_F plus I_H . While the two terminal currents may have any angular relationship with one another, most outfeed conditions display a nearly out-of-phase relationship. The out-of-phase condition illustrated is the most difficult case for phase comparison, as well as the most common outfeed condition.

In the offset keying technique, the keying threshold is displaced in the positive direction, away from the zero axis. The local square wave thresholds are displaced negatively. To maintain security, the local thresholds are separated from each other, providing “nesting” during external faults. Typical settings are shown in Figure 2-9.

Figure 2-10 illustrates the square wave characteristics of offset keying for normal internal faults, external faults, and internal faults with outfeed.

The segregated Phase Comparison scheme incorporates a high degree of security. Its design is based on extensive field experience and the model line tests for the very long, series capacitor-compensated EHV lines.

Output trip signals are supervised by an arming input and a number of security checks (see Figure 2-8). Phase arming is performed by a current rate-of-change detector that responds to sudden increases, decreases, or angular shifts in current. It operates on current changes of 0.5 A or more, with an operating time of 2 ms. Ground

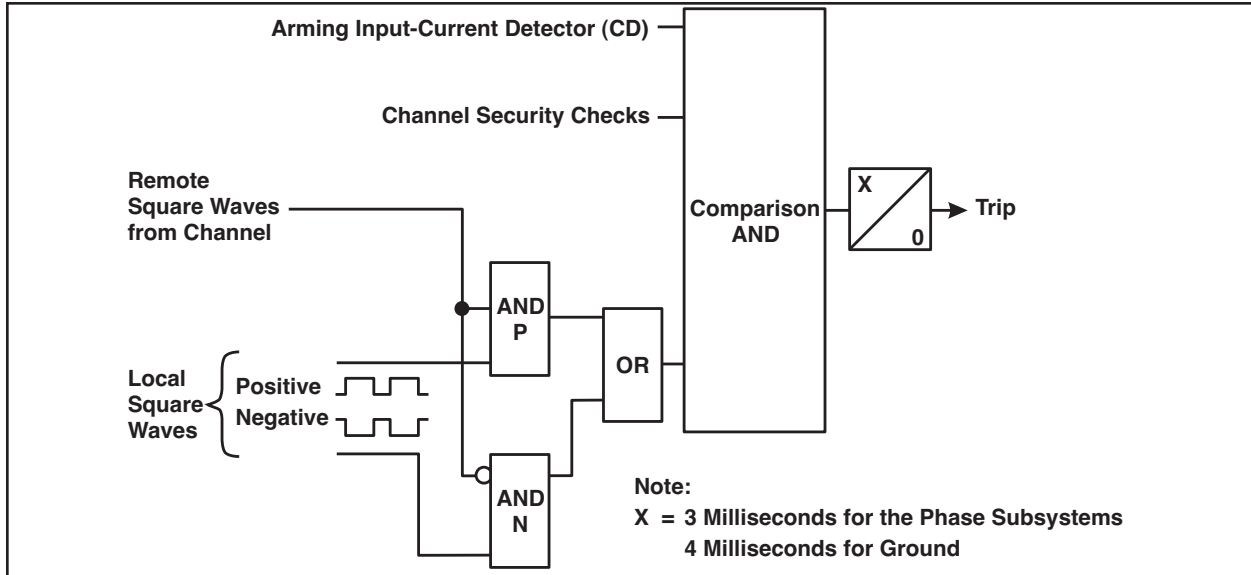

Figure 2-7. Basic Operation of the Segregated Phase Comparison System.

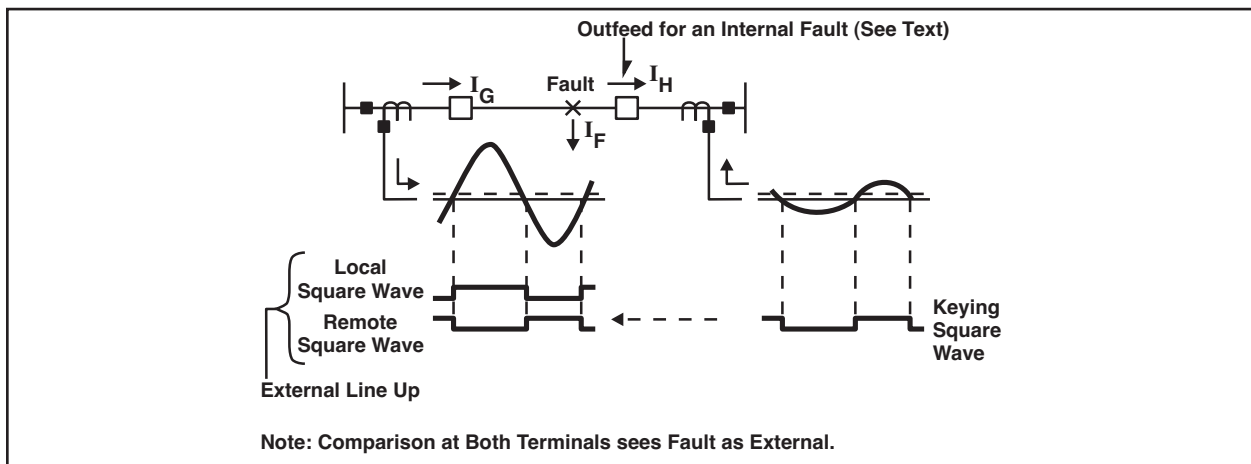

Figure 2-8. Conventional Phase Comparison Response to an Outfeed Condition Block Tripping.

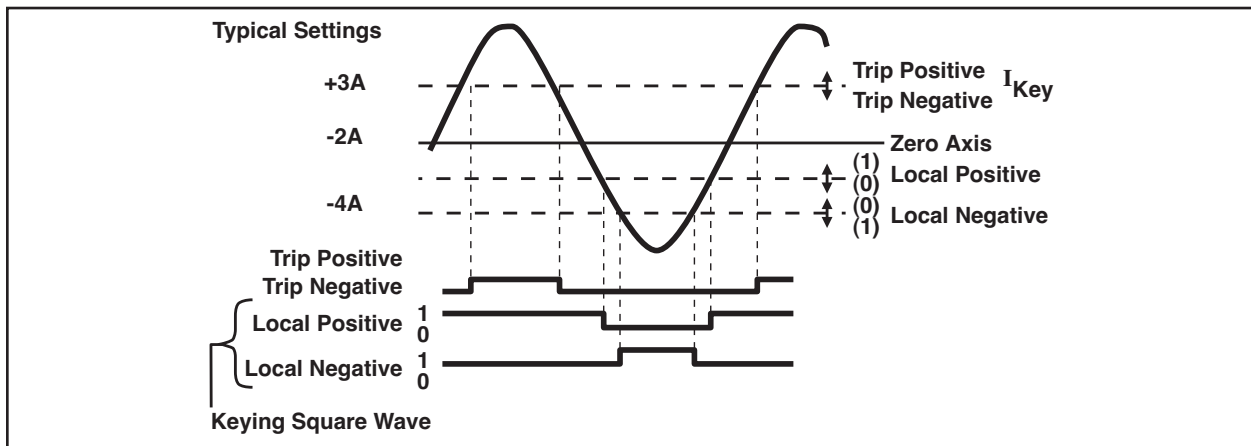

Figure 2-9. Typical Threshold Setting for Offset Keying.

arming is 3I magnitude—typically 0.8 A secondary.

Security checks to comparison AND (see Figure 2-8) include (1) low channel signal blocking, (2) lockout for sustained low channel signal, (3) channel noise clamp, and (4) receive guard block. For the phase subsystems, a trip signal occurs if comparison AND has an output for more than 3ms (4ms for the ground subsystem).

2.2 Direct Transfer-Trip Systems

Direct transfer-trip systems provide circuit-breaker tripping at remote or receiver terminals, without any supervision by fault detectors. The most important consideration in a direct transfer-trip system is the type of channel applied. The communications equipment must carry the total burden of system security and dependability.

Direct transfer-trip systems are applied for:

- Line protection with non-permissive under reaching transfer-trip systems.
- Transformer protection where there is no circuit breaker between the transformer and transmission line.
- Shunt reactor protection.
- Remote breaker failure protection.

A sample schematic is shown in figure 2-11.

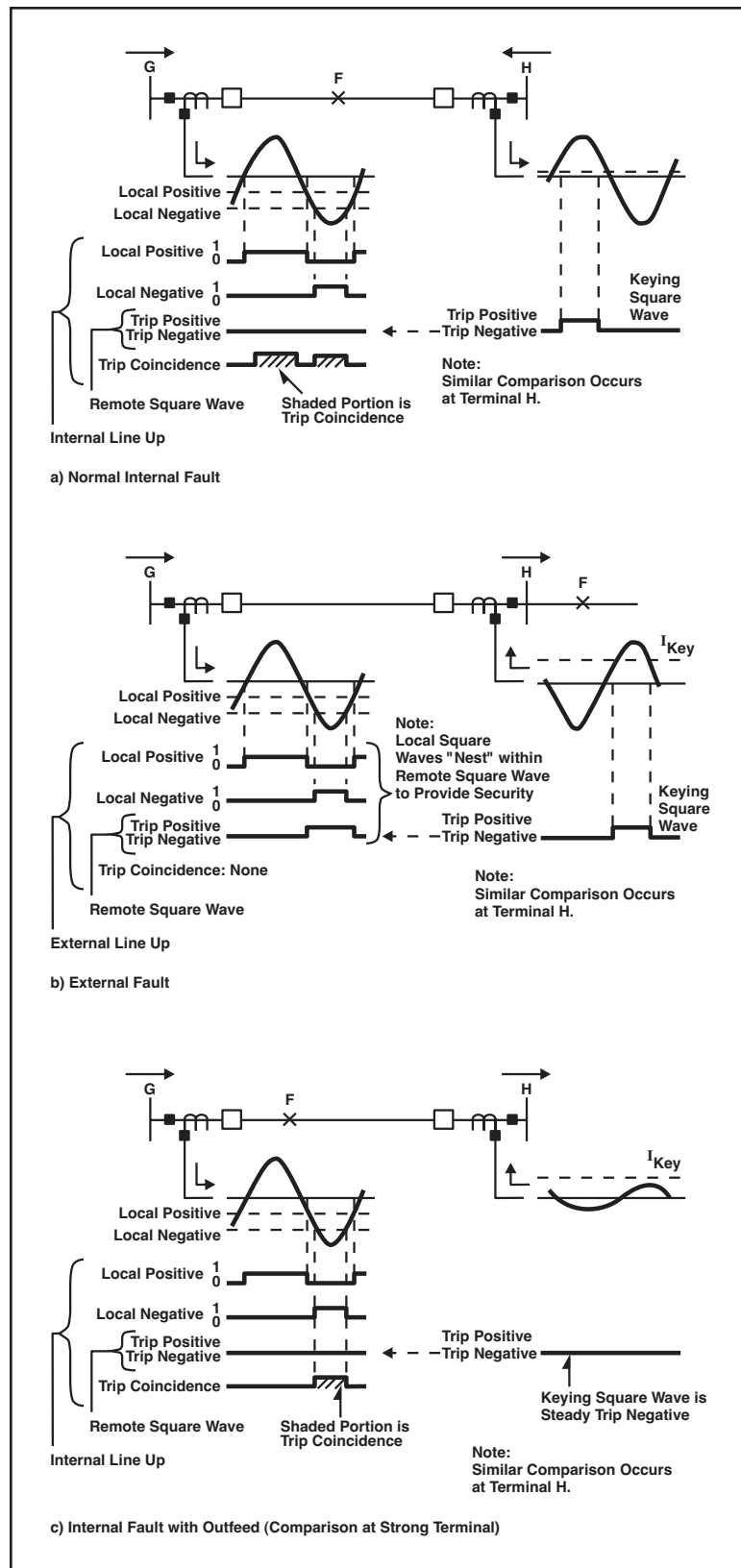

Figure 2-10. Response of Segregated Phase Comparison System with Offset Keying.

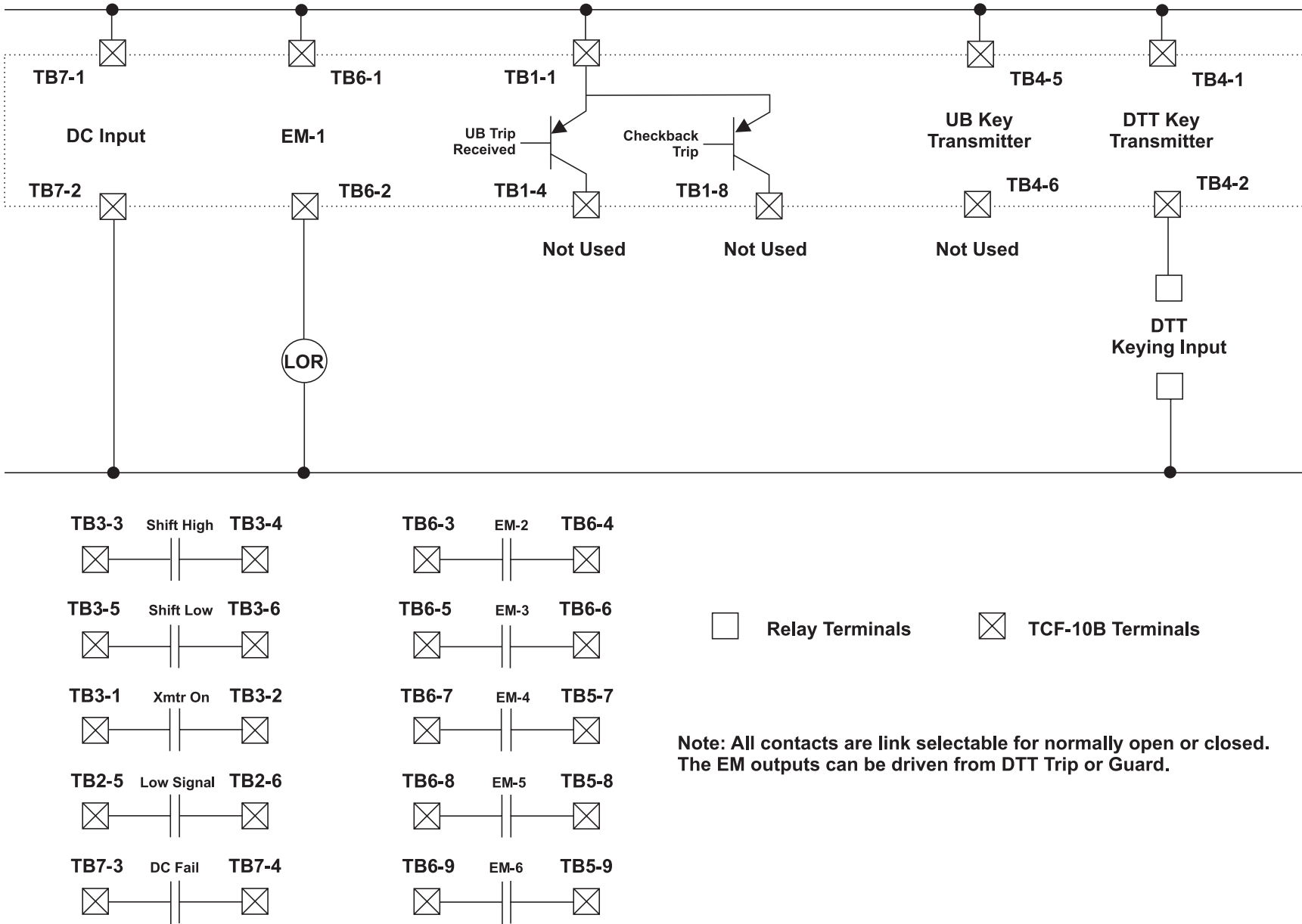

Figure 2-11. TCF-10B Transceiver Unit Connections 2 Freq. set (Single Channel Direct Transfer Trip) Typical Catalog: C2N1B2END

2.2.1 Transformer Protection

A typical transformer protection scheme is illustrated in Figure 2-12. A direct trip channel is keyed to the trip state when the transformer protective relays operate. The received trip signal will then trip the remote end breaker and lock out reclosing.

Although it is no longer widely used, you may use a ground switch operated by the transformer protective relays for transformer protection. In this technique, a ground fault is initiated on the transmission line at G, providing adequate fault current for the ground relays at H to trip the breaker at H. This system is slower but is widely used on lower voltage systems and is fairly simple and straightforward. It does not require any secure communication medium between G and H. For this type of application, the ground relays at H can be set to operate for 100 percent of the line and not overreach to bus G.

While a single switch on one phase is normally applied, you may use a double switch on two phases to initiate a double-phase-to-ground fault. In the latter case, both phase and ground relays can operate to ensure redundancy. Fault grounding is not applicable to all systems because of high short-circuit capacity.

2.2.2 Shunt Reactor Protection

Shunt reactors are frequently used on HV and EHV lines. These line reactors are connected on the line side of the circuit breakers (see

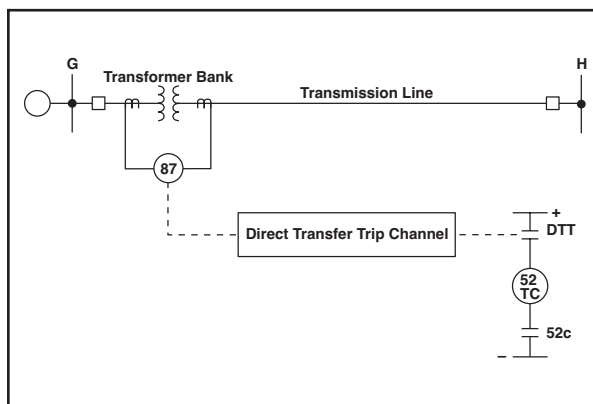

Figure 2-12. Direct Transfer Trip for Transformer Protection.

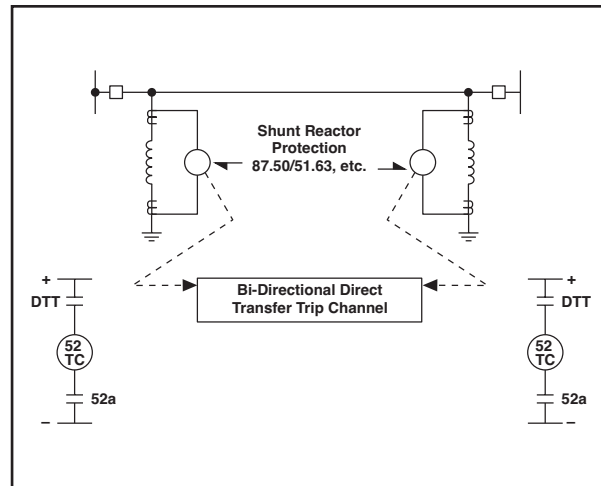

Figure 2-13. Direct Transfer Trip for Shunt Reactor Protection.

Figure 2-11). A remote trip channel is thus required for a fault in the shunt reactor.

2.2.3 Remote Breaker-Failure Protection

A remote breaker-failure system is necessary where a multi-breaker bus, such as a breaker-and-a-half or ring bus scheme, is applied at a transmission line terminal. A direct transfer-trip system will be a part of the remote breaker-failure protection.

2.2.4 Direct Trip Channel Considerations

The channel and its terminal equipment are major factors in the proper operation of the direct transfer-trip system. The channel must neither fail to provide a correct trip signal nor provide a false signal.

While other types of modulation are possible, frequency-shift keyed (FSK) equipment offers the best compromise between noise rejection capability and equipment complexity. Two frequencies are usually transmitted in an FSK system: the “guard” frequency is transmitted during non-trip conditions and the “trip” frequency is transmitted when a breaker trip is required. Because a signal is always present, the FSK system will allow the channel to be continuously monitored. Continuous channel monitoring is necessary in a direct trip

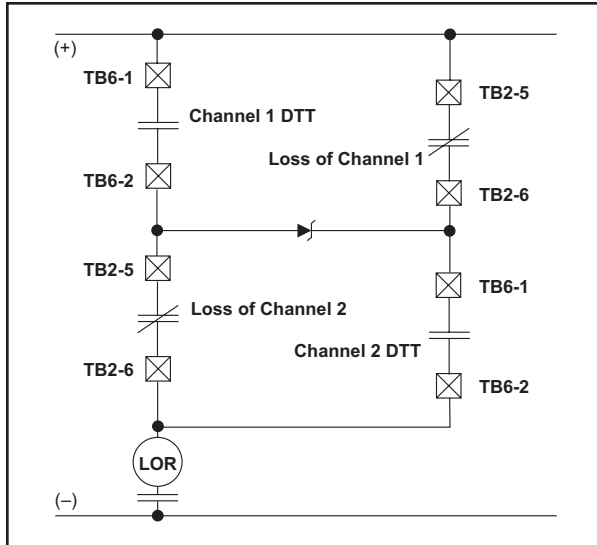

Figure 2-14.

Dual Channel Direct Transfer Trip with Throwover to Single Channel.

system, because breaker tripping is not supervised by any local relays.

As noise in the channel increases, a point is reached where there is a high probability of false tripping. The level of noise at which the channel becomes unreliable must be determined by tests. Signal-to-noise ratio monitors must then be included with any direct trip channel, to block possible false tripping. It is important, however, not to get the noise monitors any more sensitive than required, since their operation will prevent tripping.

There are three important aspects to the application of FSK channels to direct trip systems: channel bandwidth, dual channel systems, and channel protection.

Although faults should be cleared in the shortest possible time, speed is not the only criterion for selecting equipment. *It is important to use the narrowest bandwidth equipment possible.* A wide bandwidth channel may give the desired speed, but more noise enters the system. Thus, the channel will block tripping sooner than a narrower bandwidth channel with the same received signal level. A wideband channel will consequently not

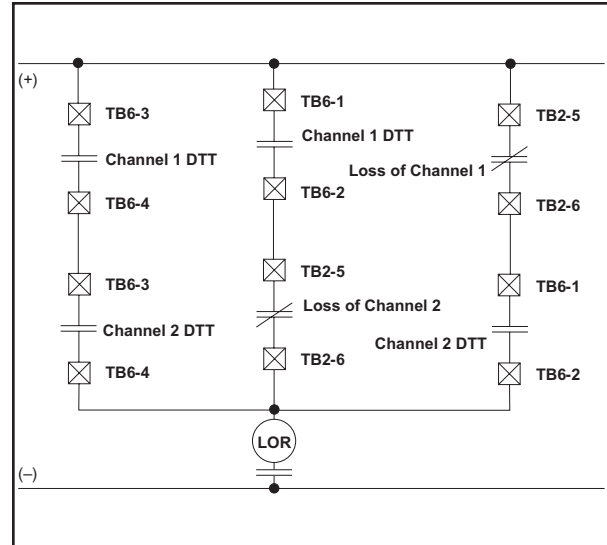

Figure 2-15.

Dual Channel Direct Transfer Trip with Throwover to Single Channel.

be as dependable as a narrower channel under equal receive-level conditions.

A dual channel system is recommended for direct trip applications. Two FSK channels should be used in series, so that both must trip before the breaker is tripped. Many tests have indicated that dual channels improve the security of the direct trip system by several orders of magnitude. Use of a dual channel system has very little effect on dependability, even if both channels are on the same transmission medium.

If you want to increase the dependability, you can modify the dual channel transfer trip scheme to allow a single channel trip when there is failure of the other channel. A typical Dual Channel Throwover to Single Channel Scheme is illustrated in Figures 2-14 & 2-15.

2.3 Special Considerations

The TCF-10B frequency-shift equipment can operate in either the two- or three-frequency mode, but ordinarily operates as a two-frequency system. The three basic frequencies are as follows (see Figure 2-16):

f_c Center frequency

- f_H High-frequency, is a frequency shift (Δf) above f_C
- f_L Low-frequency, is a frequency shift (Δf) below f_C

The value of Δf depends on the bandwidth of the TCF-10B set. For a bandwidth of 1600 Hz, Δf is 500 Hz. A bandwidth of 380 Hz yields a Δf of 100 Hz, while the 800 Hz bandwidth Δf can be either 250 or 100 Hz, depending on the setting of S5 on the Transmitter Board. The center channel frequency (f_C) can vary from 30 to 535 kHz (in 0.5 kHz steps).

In the two-frequency systems, only f_H and f_L are used. The two frequencies function differently and take on different labels when operating with the different types of protective relay systems.

2.3.1 Directional Comparison Unblocking (Two-Frequency)

The higher frequency (f_H), or “Guard” frequency, is transmitted continually as a blocking-type signal during normal conditions, to indicate that the channel is operative and to prevent remote relay tripping when external faults occur.

For a fault sensed by the local overreaching pilot relay, the transmitter is frequency-shifted to a low frequency (f_L), called “Unblock” frequency. The transmitted power is normally 1 W, boosted to 10 W for the “Unblock” operation.

The Directional Comparison Unblocking system will generally use the wide band, wide shift (800 Hz BW, ± 250 Hz Shift) TCF-10B carrier set. Also, the most common power output level used will be the 1 watt block and 10 watt trip. The type of carrier applied with this scheme may be varied from the normal for special circumstances, e.g., when matching the new TCF-10B equipment at one end of the line with the older TCF, TCF-10, or TCF-10A equipment at the other end. In this case, you must apply the wide band, narrow shift carrier (800 Hz BW, ± 100 Hz Shift) to match the older carrier characteristics.

2.3.2 Transfer Trip: Overreaching, Underreaching or Direct (Two-Frequency)

The higher frequency (f_H), or “Guard” frequency, is transmitted continually during normal conditions. For a fault sensed by the overreaching (or underreaching) pilot relay, the transmitter is shifted to the low frequency (f_L), called “Trip” frequency.

When using the TCF-10B for any permissive overreaching or underreaching line relay system, you can apply any bandwidth set. However, the best all around set to use will be the wide band, wide shift (800 Hz BW, ± 250 Hz Shift) equipment. If signal-to-noise ratio is of concern, however, you may use the narrow band set; on the other hand, if relay speed is critical, you may apply the extra wide band (1600 Hz, ± 500 Hz Shift) equipment. If, in direct transfer trip systems, security due to S/N is of concern, we strongly recommend that you apply only narrow band equipment. In any of these systems, the usual power level combination will be 1 watt for guard and 10 watts for the trip signal.

2.3.3 Phase Comparison Unblocking: Dual or Segregated (Two-Frequency)

Phase Comparison relays use square wave signals for operation. The transmitter is keyed to a “Trip Positive” frequency when the relay square wave goes positive, and is keyed to a “Trip-Negative” frequency when the relay square wave is at zero. The Trip Positive frequency is frequency-shifted below f_C ; the “Trip Negative” frequency is frequency-shifted above f_C . Either frequency can function as a trip or block, depending on the local square wave.

For Phase Comparison systems, you can use only the wide band with wide shift or extra wide band TCF-10B. In the interest of conserving spectrum, the wide band, wide shift channel is most common. However, if speed is important, you may apply the extra wide band set. The most often applied power level will be 10 watts for both “Trip-Positive” and “Trip-Negative”.

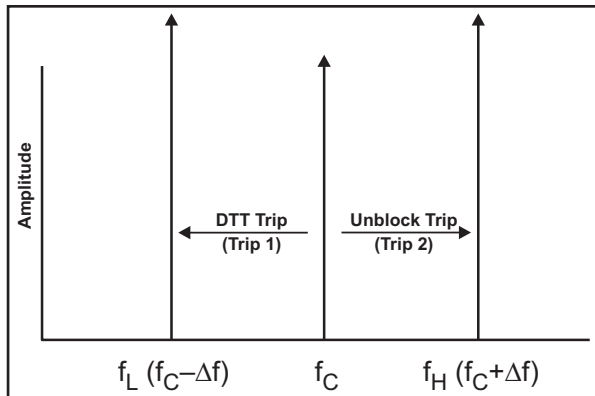

Figure 2-16. TCF-10B 3-Frequency System.

2.3.3.1 Phase Comparison Relaying and 20V Auxiliary Power Supply

When ordering a TCF-10B for use with phase comparison relaying, a 20V auxiliary power supply is provided.

The majority of interfaces between the relay and the communications equipment are done at the station battery. If the control battery is 125 Vdc, then the carrier output will be powered up with 125 Vdc to provide station battery voltage to the relay. However, in phase comparison relay systems, the ratio, of the on and off state, of the carrier circuit output and the on and off state of the relay's keying circuit is critical to provide a square wave that closely represents the power system ac wave. Therefore, based on the type of inputs used on the relay system at the point it interfaces with the carrier system, this will determine what voltage level is acceptable. This criticality is on the order of 500 or less microseconds.

Due to the capacitors typically applied to output circuits to dampen surges, the higher the voltage applied, the longer it will take to dissipate the energy. Therefore, to dissipate this energy quickly, to adhere to the timing requirements for a secure phase comparison relay system, the use of the auxiliary 20V power supply is necessary. Different relay manufacturers' input circuits may vary and can conceivably decay fast enough not to hinder the security of the relay system operation. However, the energy dissipated will also generate a significant amount of heat. By utilizing the auxiliary supply, mounted on the rear of the

carrier unit, it will allow that heat to be outside of either unit.

Pulsar strongly recommends the application of the auxiliary power supply for two reasons; decay time of the energy, and the heating caused by the dissipation of energy.

2.3.4 Three-Frequency Systems

The TCF-10B also provides for three-frequency system applications (see Figure 2-16), e.g., Directional Comparison Unblocking with Direct Transfer Trip, or Permissive Overreaching Transfer Trip with Direct Transfer Trip. All three frequencies are closely-controlled discrete frequencies within the equivalent spacing of a single wideband or extra wideband channel. In applying a three-frequency system, the Direct Transfer Trip keying inputs shifts the channel low (i.e., -250 Hz for 800 Hz bandwidth) and the unblock key shifts the channel high (i.e., +250 Hz for 800 Hz bandwidth).

See figure 2-17 for a sample schematic.

2.3.5 Three terminal line applications.

When a three terminal line protection requires power line carrier equipment, each terminal must have one transmitter and 2 receivers, since each terminal must receive a signal from each of the 2 other ends of the line. Fig. 2-18 is a representation of the transmitter/receiver complement required to implement a single function: Hybrids or other isolation devices are required between transmitters and transmitters to receivers. See the following section for details.

2.4 Hybrid Applications

The purpose of the hybrid is to enable the connection of two or more transmitters together on one coaxial cable without causing intermodulation distortion due to the signal from one transmitter affecting the output stages of the other transmitter. Hybrids are also required between transmitters and receivers, depending on the application. The hybrid circuits can, of course, cause large losses in the carrier path and must be used appropriately. High/low-pass and band-pass networks may also be used, in some applications, to isolate carrier

Figure 2-17. TCF-10B Transceiver Unit Connections 3 Frequency Set
 (Unblock Relaying and Direct Transfer Trip) Typical Catalog: C2M1B3END or C2M1B3ETD

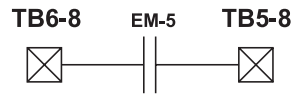
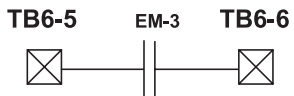
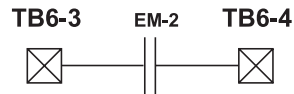
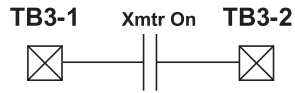
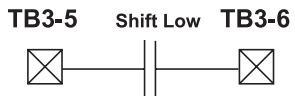
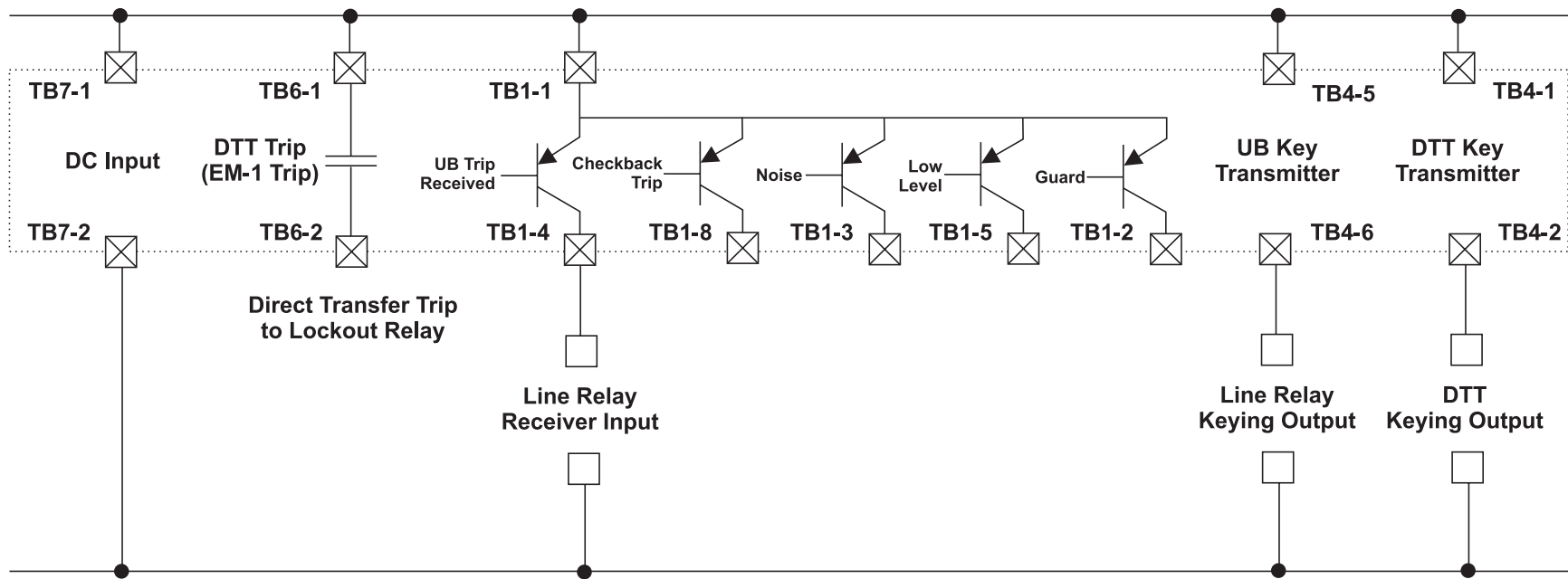

□ Relay Terminals ⊠ TCF-10B Terminals

Note: All contacts are link selectable for normally open or closed.
 The EM outputs can be driven from UB Trip (Trip 2),
 DTT Trip (Trip 1) or Guard.

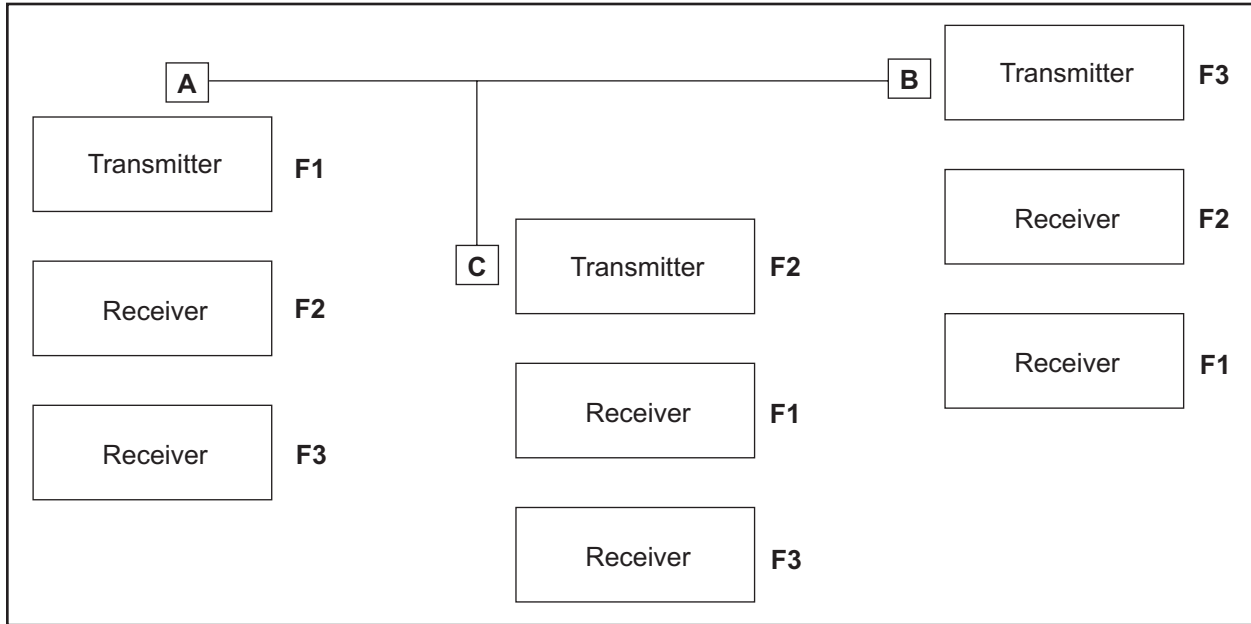

Figure 2-18. Three terminal line application.

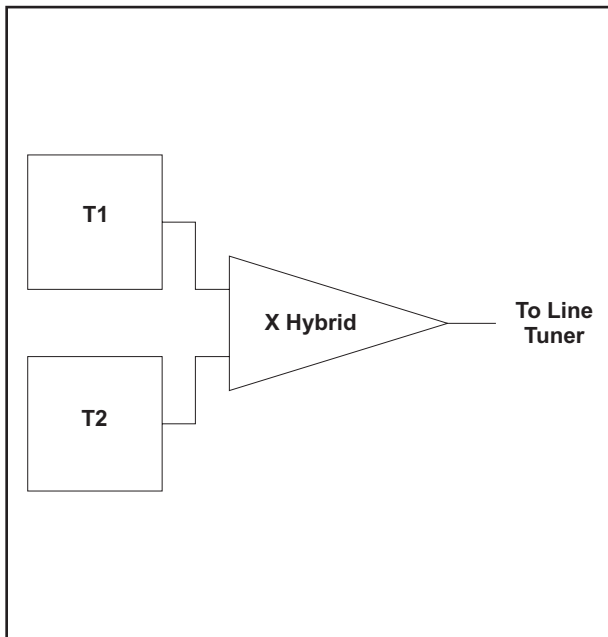

Figure 2-19. Hybrid Connections – Two Transmitters.

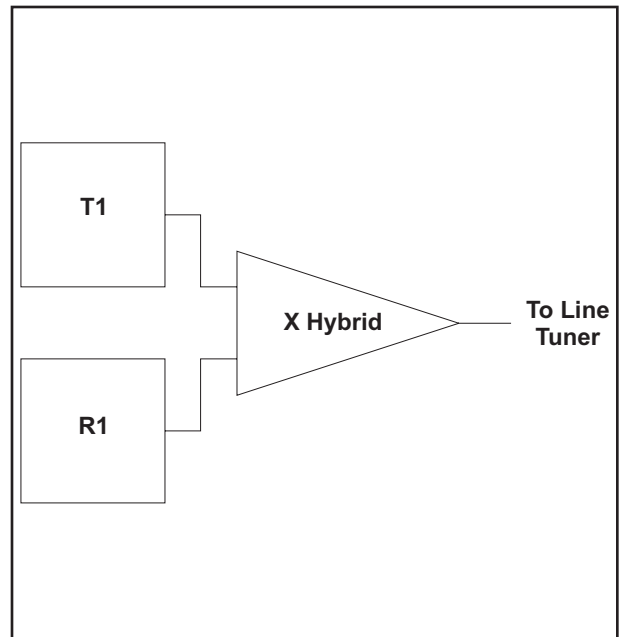

Figure 2-20. Hybrid Connections – Single Bi-Directional Channel.

equipment from each other. Several typical applications of hybrids are shown in the following diagrams, Figures 2-19 through 2-23. A summary of some of the more important application rules are given below:

1. All hybrids in a chain should be resistive type hybrids except the last hybrid, that is, the one connected to the line tuner.
2. The last hybrid in the chain should be the reactance type hybrid or a skewed type.
3. When applying transmitters to reactance type hybrids, the frequency spacing between the widest spaced transmitters is about 4% for frequencies below 50 kHz and 6% for frequencies above 50 kHz. If this rule is not followed then the hybrid cannot be adjusted to provide the best possible isolation between all transmitters.
4. When applying transmitters and receivers to a reactance type hybrid the frequency spacing between the transmitter group and receiver group is of no concern; however, all the transmitter frequencies must meet the frequency spacing rule above. This rule is based on receivers with high input impedance.
5. When the last hybrid is a skewed type then the receiver port should be terminated with a 50Ω resistor to obtain proper isolation.

A few guidelines follow in order of importance:

1. The hybrids should be arranged with the lesser losses in the transmitter path and the greater losses in the receiver path to provide more transmitter signal levels onto the power line.

2. Transmitters that are used with wide bandwidth channels should be arranged with lower losses and those of narrower bandwidths should have the higher losses.
3. Narrow band systems are not as susceptible to noise as wider band systems are, therefore they can tolerate the higher loss.

If possible, transmitters used for common applications should be arranged for equal attenuation. This would apply to systems that use dual channels such as Direct Transfer Trip (DTT) or Segregated Phase Comparison.

Following are the type of hybrids and their associated style numbers.

2.4.1 Examples

Following are several figures that illustrate possible hybrid applications. A short description of each follows.

In these illustrations, Resistive Hybrids are denoted as R hybrids, Reactive hybrids as X hybrids and Skewed hybrids as S hybrids. Fig. 2-19 illustrates two transmitters being combined onto a single coax cable for connection to a line tuner. This would be a typical application for a dual channel, uni-directional trip system. The receive end of the system would not require a hybrid so that the receivers would be tied together via coax cable before connection into the line tuner.

When only one transmitter and one receiver are required as in a single channel bi-directional transfer trip system or a directional comparison unblocking system Fig. 2-20 can be applied. A skewed hybrid may be used in place of the

• Resistive Hybrid	H1RB	6266D72G05
• Skewed Hybrid with terminating resistor	H1SB-R	1609C45G03
• Reactance Hybrid	H3XB	6266D71G03
• 19" panel suitable for 3 Hybrids		670B695H01
For details, please refer to the Hybrids System manual, CH44.		

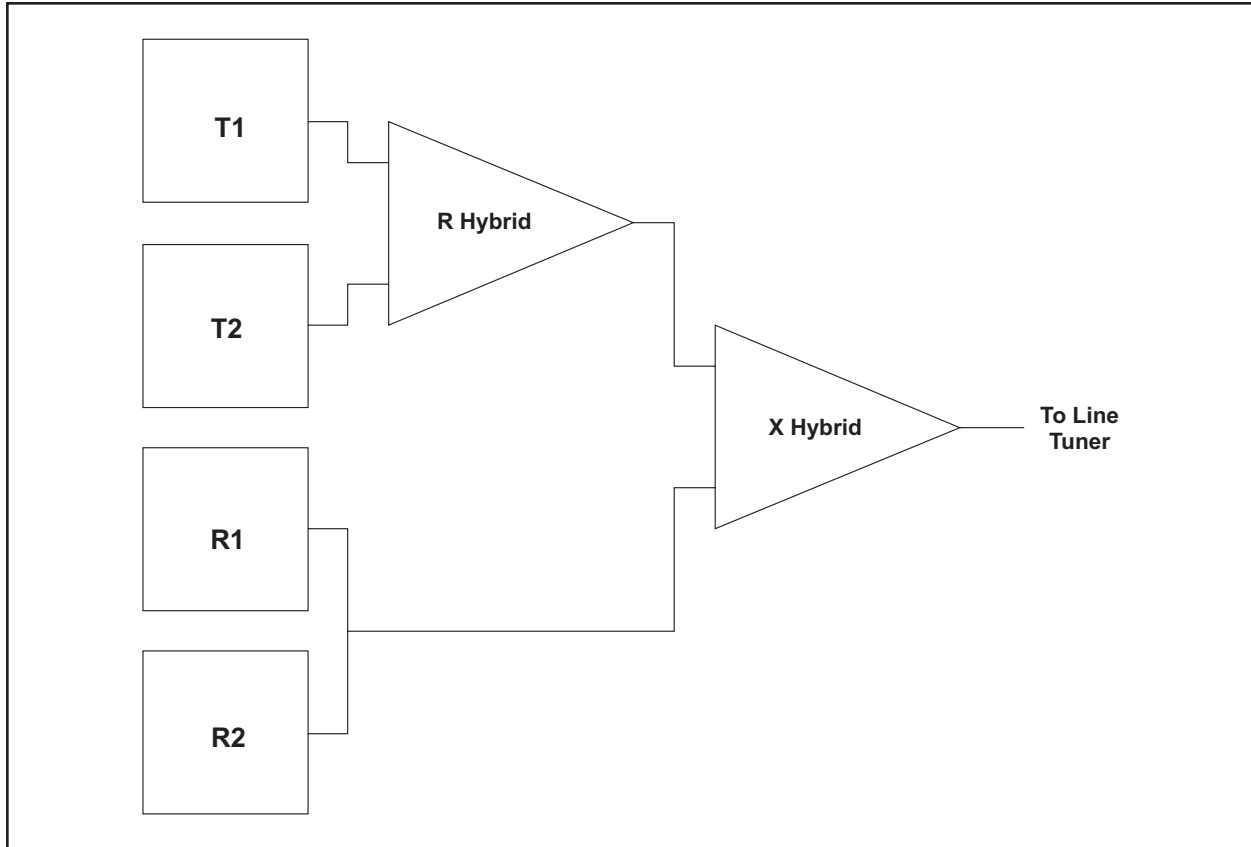

Figure 2–21. Hybrid Connections – Dual Bi-Directional Channel.

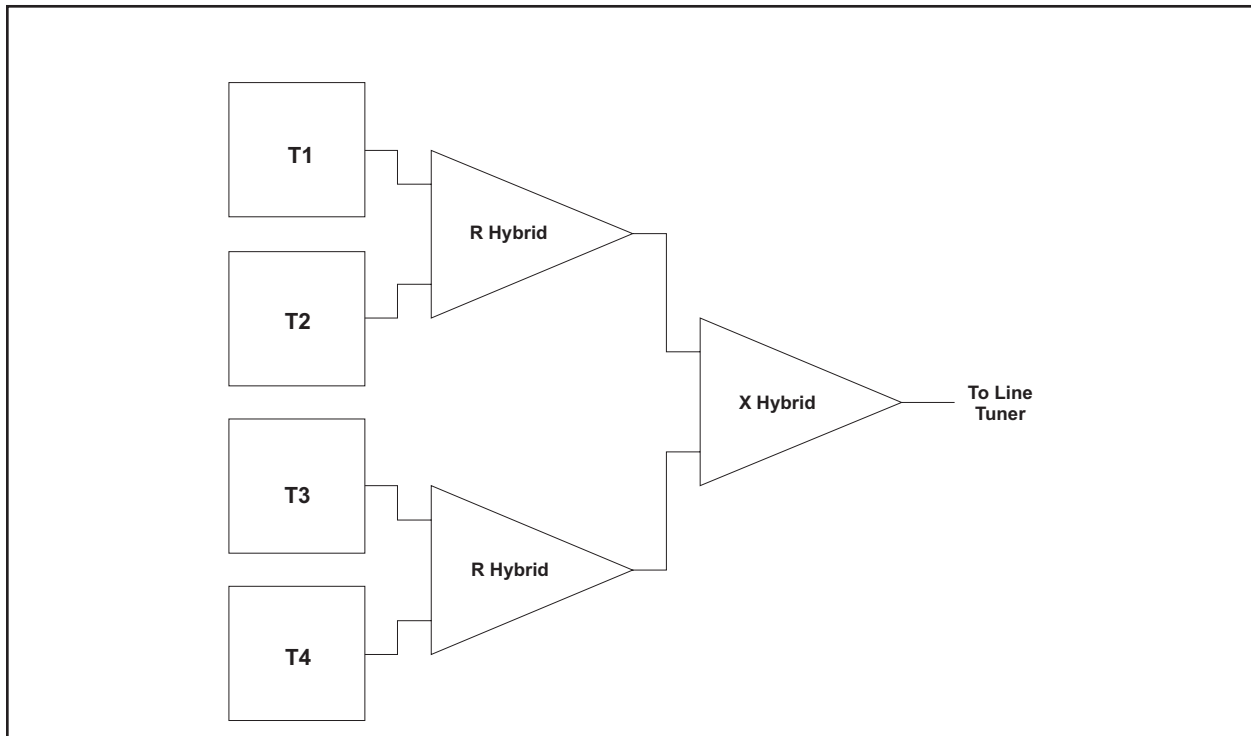

Figure 2–22. Hybrid Connections – Four Transmitters (Equal Losses).

reactive hybrid (X hybrid). The skewed hybrid has a designated transmit port and receive port.

When two transmitters and two receivers are being applied to a single coax cable, as in a dual channel bi-directional direct transfer trip system, Fig. 2-21 is appropriate.

Four transmitters used for similar applications can be combined as shown in Fig. 2-22. This would be representative of two dual channel uni-directional

transfer trip systems. This provides equal losses to each transmitter.

When different types of modulation and different bandwidths are utilized, it is better to arrange the transmitters and receivers as shown in Fig. 2-23. This allocates loss based on performance factors of the modulation type and bandwidth.

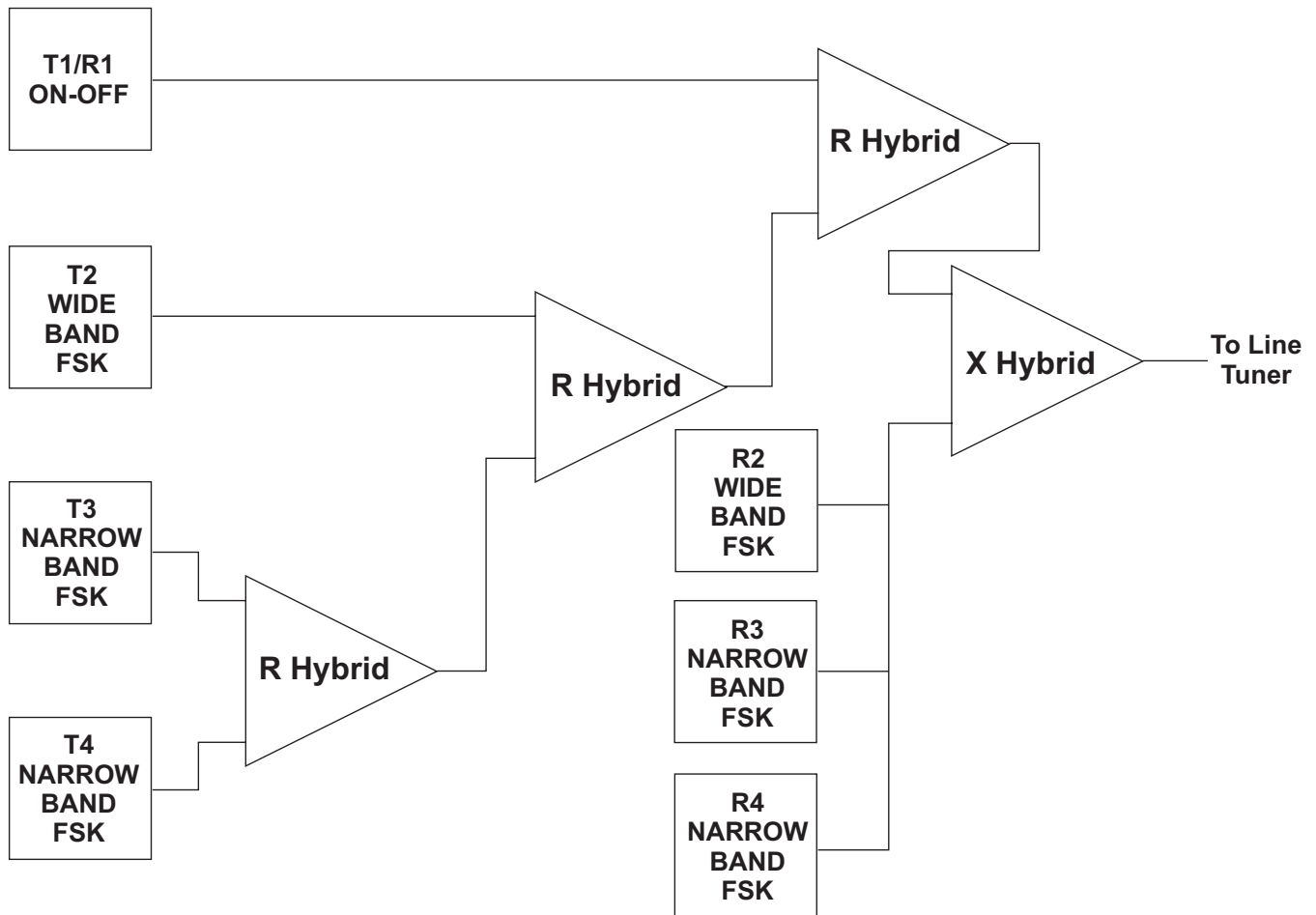

Figure 2-23. Hybrid Connections – Four Transmitters (Unequal Losses).

2.5 Ordering Information

The equipment identification number (catalog number) is located in the center of the TCF-10B front panel. The TCF-10B catalog number comprises nine (9) characters, each in a specific position. This number identifies the unit's technical characteristics and capabilities, as well as any optional modules installed in the unit.

Table 2-4 provides a complete listing of the options for ordering a TCF-10B, as well as a sample catalog number. To order one or more TCF-10Bs, simply identify the features and optional modules you want for each chassis. For example, the typical catalog number shown in Table 2-4 — C 2 N 1 B 2 E N D — orders a TCF-10B with the following features:

Chassis: Transmitter/Receiver

Transmitter Power Output: 1/10 W

Bandwidth/Frequency Shift: 380 Hz BW \pm 100 Hz Shift (Direct Transfer Trip)

Power Supply: 110/125 Vdc battery input

Alarms & Carrier Level Indication: with alarms

Channel Type: 2-Frequency

Receiver Output Interface: Electro-mechanical (six contact outputs)

Voice Adapter/Trip Test Unit: No Voice Adapter Module

Receiver Logic: Directional Comparison (Unblock, POTT, PUTT, DUTT, or Direct Transfer Trip)

The TCF-10B accessories are listed in Table 2-3.

Table 2-3. TCF-10B Accessories.

Accessories for Voice Adapter	Module	Style Number
Sonalert (2,900 Hz, 60–250 Vdc)		SC250J
Telephone Hook switch Assembly (panel mounting) with Noise Cancelling Handset (single prong plug)		205C266G01
Telephone Handset, Noise Cancelling		1353D88G02

Other Accessories	Module	Style Number
20 Volt Power Supply†	48 Vdc	1610C07G01
	125 Vdc	1610C07G02
	250 Vdc	1610C07G03
TC-10B/TCF-10B Extender Board		1353D70G01

† (For use with some phase comparison relaying equipment or older solid state equipment.)

Table 2-4. TCF-10B Catalog Numbers

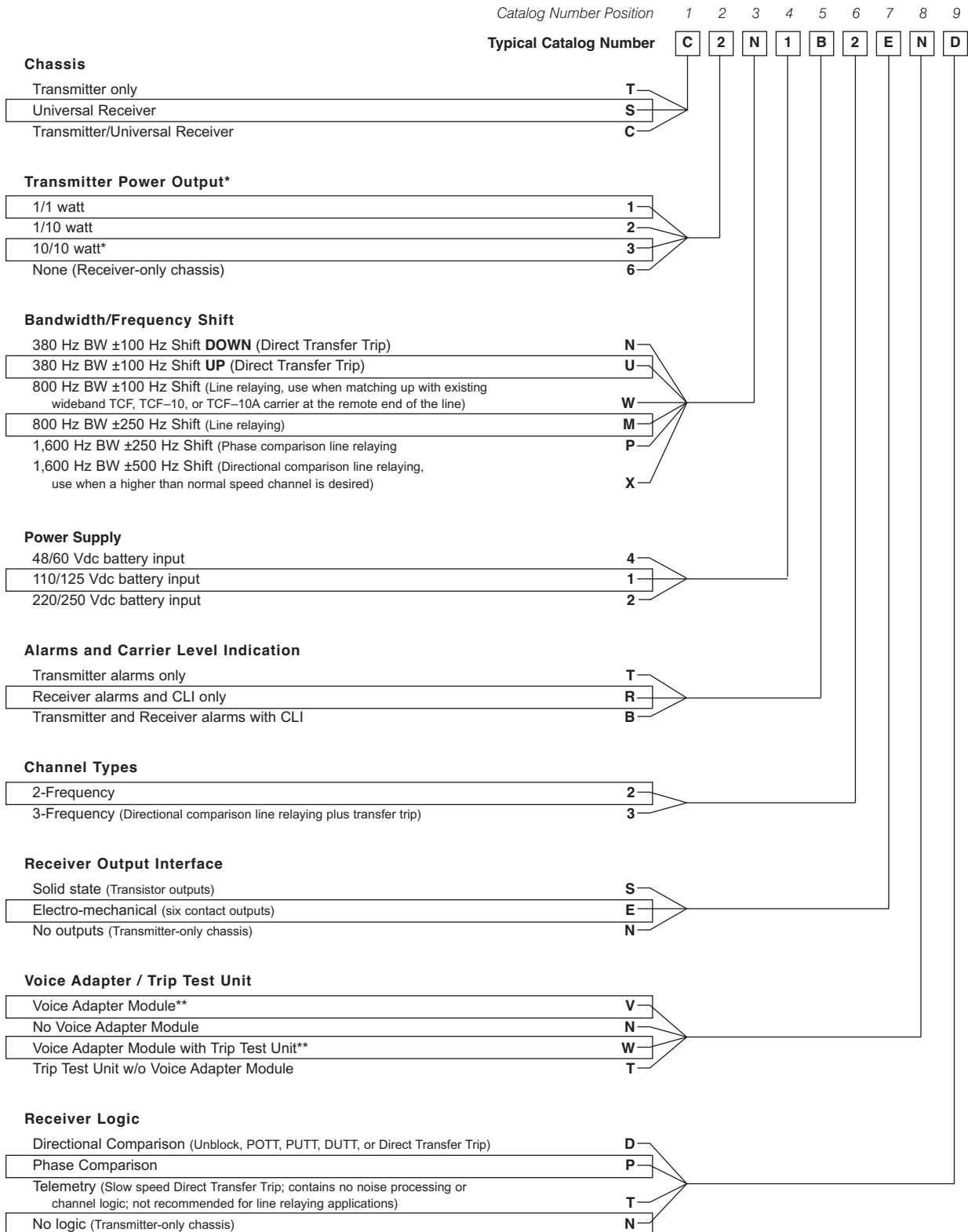

*For 50 or 100 watt output, see Accessories

**Available in Transmitter/Receiver chassis only.

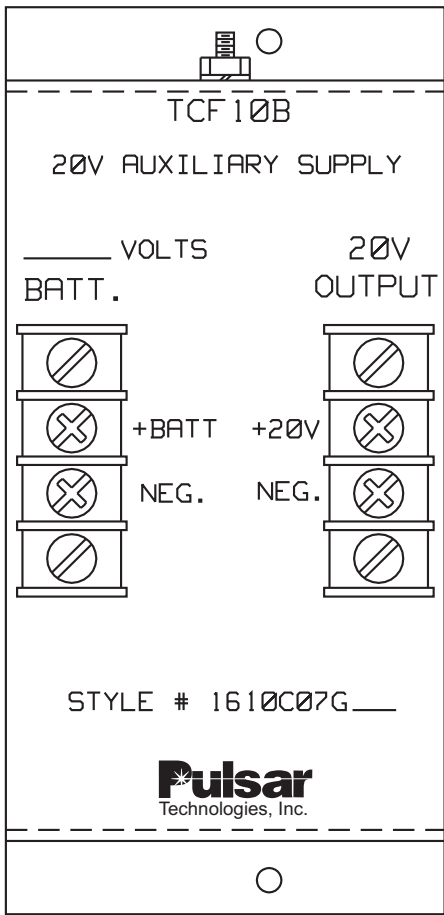

TOP VIEW

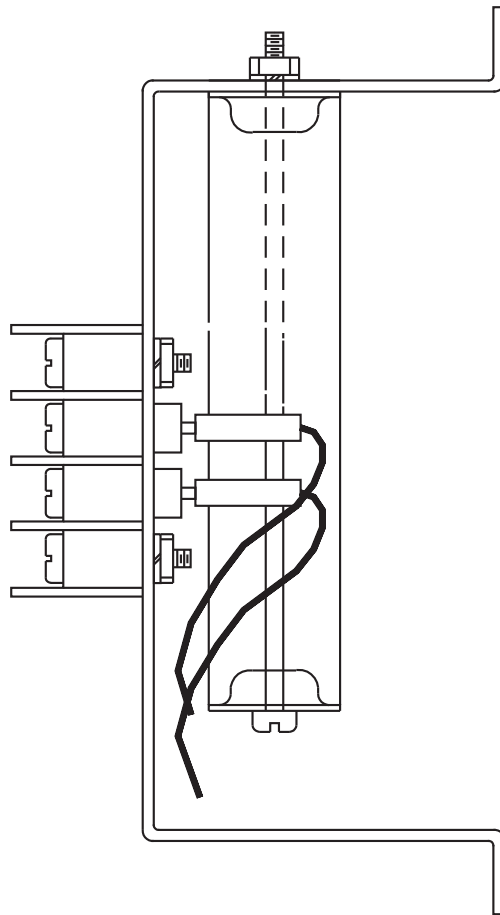

RIGHT SIDE VIEW

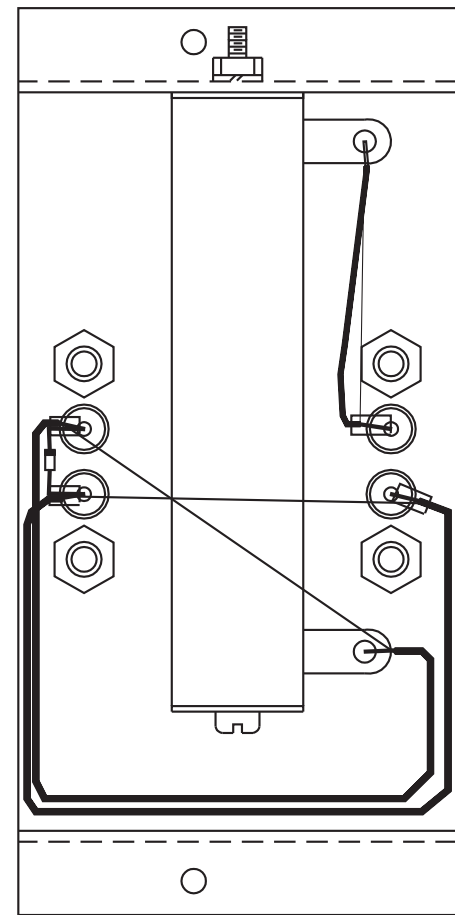

BOTTOM VIEW

Figure 2-24. 20 Vdc Auxiliary Power Supply (1610C07; Sheet 1 of 2).

Figure 2-25. TCF-10B Catalog Numbers/Module Style Numbers (1355D19)

C 2 2 N 1 4 B 2 5 E 2 7 N 3 8 D 1 9

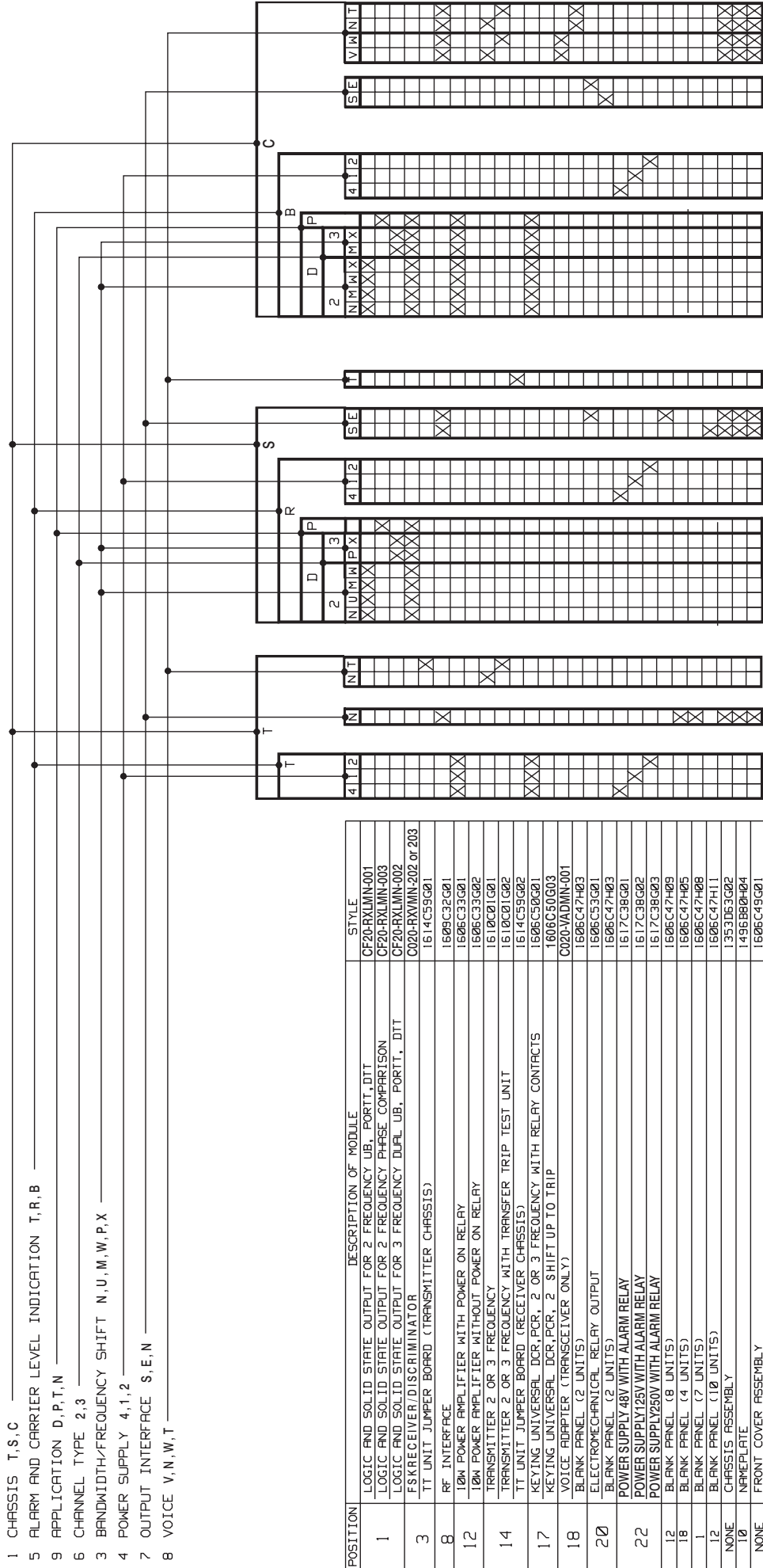

- 1 CHASSIS T, S, C
- 5 ALARM AND CARRIER LEVEL INDICATION T, R, B
- 9 APPLICATION D, P, T, N
- 6 CHANNEL TYPE 2, 3
- 3 BANDWIDTH/FREQUENCY SHIFT N, U, M, W, P, X
- 4 POWER SUPPLY 4, 1, 2
- 7 OUTPUT INTERFACE S, E, N
- 8 VOICE V, N, W, T

POSITION	DESCRIPTION OF MODULE	STYLE
1	LOGIC AND SOLID STATE OUTPUT FOR 2 FREQUENCY UB, PORIT, DTT	CF20-RXLMN-001
	LOGIC AND SOLID STATE OUTPUT FOR 3 FREQUENCY PHASE COMPARISON	CF20-RXLMN-003
	LOGIC AND SOLID STATE OUTPUT FOR 3 FREQUENCY DUPL UB, PORIT, DTT	CF20-RXLMN-002
3	FSK RECEIVER/DISCRIMINATOR	CO20-RXLMN-202 or 203
	TT UNIT JUMPER BOARD (TRANSMITTER CHASSIS)	1614C59G01
8	RF INTERFACE	1609C32G01
12	10W POWER AMPLIFIER WITH POWER ON RELAY	1606C33G01
	10W POWER AMPLIFIER WITHOUT POWER ON RELAY	1606C33G02
14	TRANSMITTER 2 OR 3 FREQUENCY	1610C01G01
	TRANSMITTER 2 OR 3 FREQUENCY WITH TRANSFER TRIP TEST UNIT	1610C01G02
17	TT UNIT JUMPER BOARD (RECEIVER CHASSIS)	1614C59G02
	KEYING UNIVERSAL DCR, PCR, 2 OR 3 FREQUENCY WITH RELAY CONTACTS	1606C50G01
	KEYING UNIVERSAL DCR, PCR, 2 SHIFT UP TO TRIP	1606C50G03
18	VOICE ADAPTER (TRANSCIEVER ONLY)	CO20-VALMN-001
	BLANK PANEL (2 UNITS)	1606C47H03
20	ELECTROMECHANICAL RELAY OUTPUT	1606C53G01
	BLANK PANEL (2 UNITS)	1606C47H03
22	POWER SUPPLY 48V WITH ALARM RELAY	1617C38G01
	POWER SUPPLY 120V WITH ALARM RELAY	1617C38G02
12	POWER SUPPLY 250V WITH ALARM RELAY	1617C38G03
18	BLANK PANEL (8 UNITS)	1606C47H03
	BLANK PANEL (4 UNITS)	1606C47H05
1	BLANK PANEL (7 UNITS)	1606C47H08
12	BLANK PANEL (10 UNITS)	1606C47H11
NONE	CHASSIS ASSEMBLY	1353DB3G02
10	NAMEPLATE	1496BB0H04
NONE	FRONT COVER ASSEMBLY	1606C49G01

X = item selected

Chapter 3. Installation

3.1 Unpacking

If the TCF-10B is shipped unmounted, it is packed in special cartons that are designed to protect the equipment against damage.

 CAUTION
<p>UNPACK EACH PIECE OF EQUIPMENT CAREFULLY SO THAT NO PARTS ARE LOST. INSPECT THE CONDITION OF THE TCF-10B AS IT IS REMOVED FROM ITS CARTONS. ANY DAMAGE TO THE TCF-10B MUST BE REPORTED TO THE CARRIER. DAMAGES ARE THE RESPONSIBILITY OF THE CARRIER, AND ALL DAMAGE CLAIMS ARE MADE GOOD BY THE CARRIER. PLEASE SEND A COPY OF ANY CLAIM TO PULSAR TECHNOLOGIES, INC.</p>

3.2 Storage

If you are setting the equipment aside before use, be sure to store it in its special cartons (in a moisture-free area) away from dust and other foreign matter.

3.3 Installation Location

Install the TCF-10B in an area which is free from:

- Temperature exceeding environmental limits (See “Environmental Requirements” in Chapter 1)
- Corrosive fumes
- Dust
- Vibration

3.4 Assembly

You can assemble the TCF-10B for use either in one of the following configurations:

- Mounted in a fixed-rack cabinet.
- Mounted in a swing-rack cabinet
- Mounted on an open rack.

or in your own, customer-specified configuration. Refer to Figure 3-3 for mounting dimensions.

 CAUTION
<p>IF YOU ARE USING THE TCF-10B WITH A SWING-RACK CABINET, MAKE SURE THAT THE CABINET IS FIRMLY FASTENED BEFORE OPENING THE RACK (TO PREVENT TIPPING).</p>

3.5 TCF-10B Rear Panel Connectors

The following connectors are accessible from the Rear Panel (See Figure 3-1 and Figure 3-4):

- Terminal Blocks.
- Cable Jacks
- Jumpers
- Input/Output Pins

NOTE

Low-powered microprocessor relays housed in a solid metal case do not allow for the necessary air circulation. If you are using this type of relay, make sure you provide one rack unit (1 RU) of space on the top and bottom of the carrier set to ensure proper air circulation.

Figure 3-1. TCF-10B Rear Panel (C020-BKPMN/1610C07).

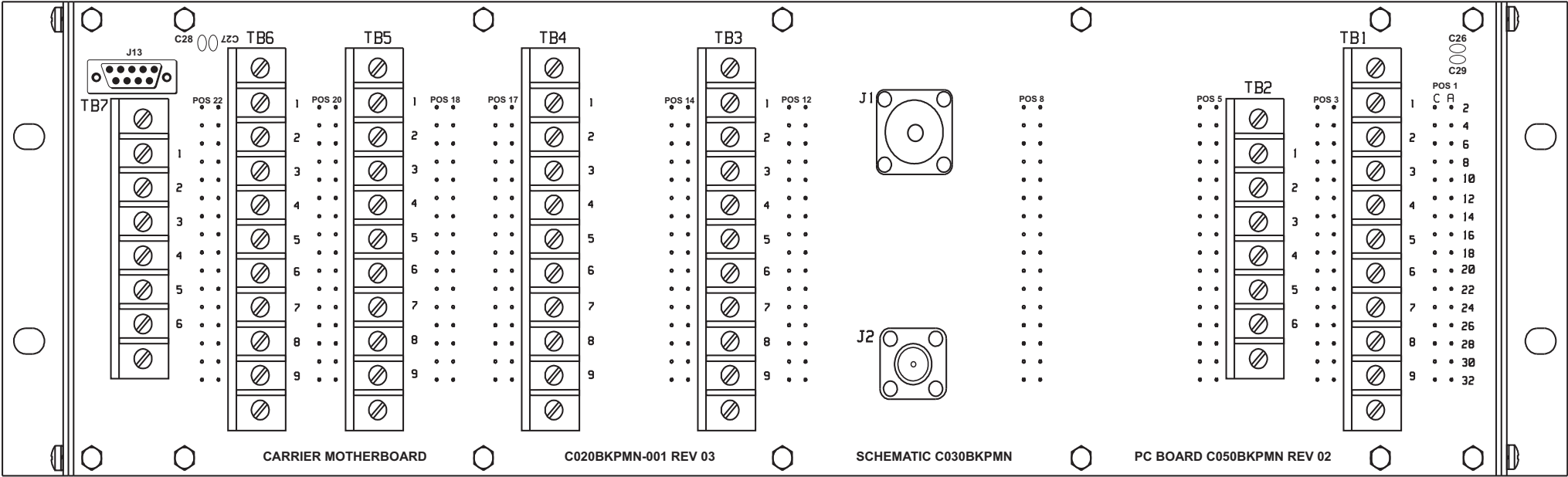

**Power Supply
mounted on rear of Chassis**

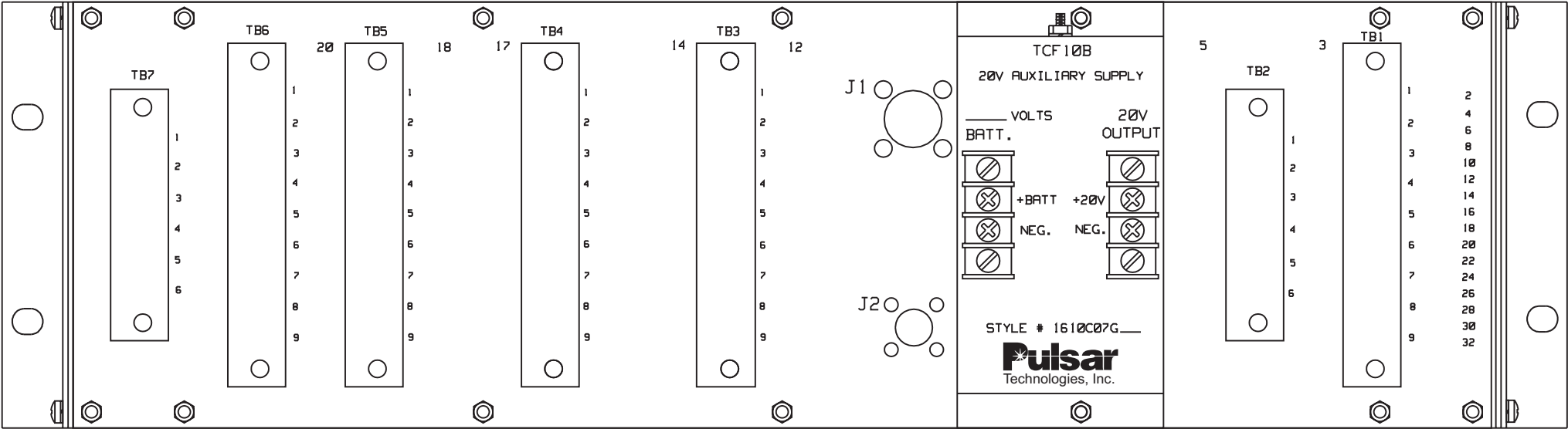

3.5.1 Terminal Blocks

(Refer to Figure 3-4 for further information.)

TB7 Power Supply	(Terminals 1 thru 6)
TB6 EM Output	(Terminals 1 thru 9)
TB5 Voice Adapter	(Terminals 1 thru 9)
TB4 Keying	(Terminals 1 thru 6)
TB3 10W PA	(Terminals 1 thru 6)
TB2 CLI and Discriminator	(Terminals 1 thru 6)
TB1 Receiver Logic	(Terminals 1 thru 9)

3.5.2 Cable Jacks

- J1 RF Interface module Transmitter, RF output line, thru 2-wire coaxial cable (UHF)
- J2 RF Interface module Receiver, RF input line thru 5,000Ω 4-wire coaxial cable (BNC)

3.5.3 Jumpers

- JU1 UHF Chassis Grd (for J1 not installed)
- JU2 BNC Chassis Grd (for J2 not installed)

3.5.4 Input/Output Pins

Pins labeled C and A provide 16 input/output connections per module (using even numbers 2 through 32 for all modules) as follows:

- Power Supply (pins are to right of TB7)
- EM Output (pins are to right of TB6)
- Voice Adapter (pins are to right of TB5)
- Keying (pins are to left of TB4)
- Transmitter (pins are to left of TB3)

- 10W PA (pins are to right of TB3)
- RF Interface (pins are to right of cable jacks and jumpers)
- Receiver (pins are to left of TB2)
- CLI and Discriminator (pins are to left of TB1)
- Receiver Logic (pins are to right of TB1)

3.5.5 Optional 20 Vdc Auxiliary Supply

(See bottom of Figure 3-1)

- Battery Input (+, -)
- 20 V Output (+20 V, negative)

3.6 Connections

3.6.1 Safety Precautions

Read this Installation Section thoroughly before making any connections to the TCF-10B. *No one should be permitted to handle any of the equipment that is supplied with high voltage, or connect any external apparatus to the equipment, unless that person is thoroughly familiar with the hazards involved.*

Three types of connections are made:

- TCF-10B equipment ground
- DC power supply and other connections
- Coaxial cables

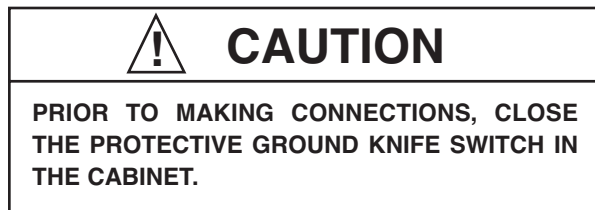

STEP 1

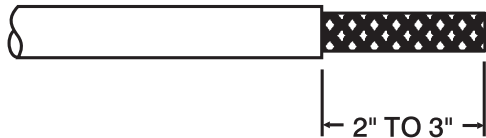

CUT THE END OF THE CABLE EVEN.
REMOVE BETWEEN 2" AND 3" OF THE VINYL
JACKET — TAKING CARE NOT TO CUT THE BRAID.

STEP 2

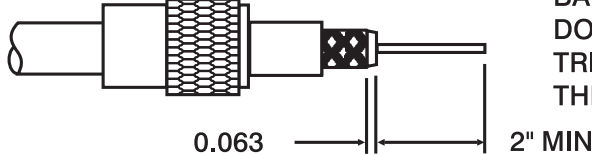

BARE 2" MINIMUM OF THE CENTER CONDUCTOR —
DO NOT NICK THE CONDUCTOR.
TRIM THE BRAIDED SHIELD 1/16" AND PUT
THE SLIDE COUPLING RING ONTO THE CABLE.

STEP 3

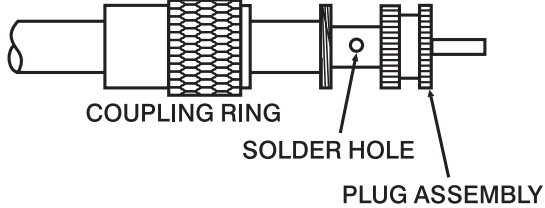

SCREW THE PLUG ASSEMBLY ONTO THE CABLE.
SOLDER BRAID THROUGH THE SIDE SOLDER HOLES
SOLDER CENTER CONDUCTOR THROUGH END.

STEP 4

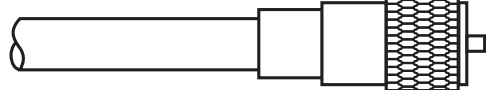

SCREW THE COUPLING RING ONTO THE ASSEMBLY.

Figure 3-2. Cable Termination Diagram (9651A13).

3.6.2 TCF-10B Equipment Ground

In addition to the TCF-10B chassis ground connection that is made through the cabinet or rack, a ground connection is provided at the Rear Panel Terminal Block (TB7). (See Figure 3-1 and Figure 3-4.) A connection should be made between TB7 Terminal 6 and the ground connection at the TCF-10B cabinet location.

3.6.3 DC Power Supply and Other Connections

Input/Output terminals, on the rear of the TCF-10B chassis, provide the connection points for the power supply (48, 125, and 250 Vdc) and customer interconnections. (See Figure 3-1 and Figure 3-4). The terminal blocks on the rear of the chassis can accept up to a 12 AWG wire with a ring lug type Burndy YAV10C36 or YAV10 or equivalent.

Any lead coming to or from the switchyard should be shielded twisted pair to protect against transients.

3.6.4 Coaxial Cable

A coaxial cable is required for a low-impedance path between the TCF-10B (Transmitter and Receiver modules) and the Line Tuner (in the switchyard). Connection jacks (J1 & J2), on the Rear Panel, provide the point for coaxial cable connection from the TCF-10B to the switchyard.

The type of coaxial cable we recommend is RG-213/U (52Ωs, 29.5 pf/foot):

- Single-conductor
- #12 AWG
- 7 strand #21 copper
- Polyethylene insulator
- Copper shield
- Vinyl jacket (nominal O.D. 0.405 inch)

If the coaxial cable is to connect to related cabinets enroute to the switchyard, you should connect the RG-58A/U cable (and Amphenol #83-58FCP or equiv. male UHF connector) from J1 or J2 to the related cabinets, and RG-213/U from the cabinets to the switchyard. Install the coaxial

cable according to the following procedures:

1. Attach both ends of the coaxial cable in accordance with the Cable Termination Diagram (see Figure 3-2, terminal block lugs, as required).
2. In order to hold carrier loss to a minimum, keep the cable the shortest possible length.

The minimum cable bending radius is six times the cable diameter.
3. The copper braid of the cable must be grounded at the end which connects to the TCF-10B.
4. Without grounding the copper braid of the cable, connect the cable to the ground terminal of the Line Tuner, at either of the following:

 CAUTION
<p>DO NOT GROUND THE END OF THE CABLE THAT IS CONNECTED TO THE LINE TUNER.</p>

- Impedance Matching Transformer
- Wideband Filter

If you are connecting the cable directly to the line tuner, the cable connector can enter the line tuner base either through the side or the bottom of the base.

 CAUTION
<p>PRIOR TO ENERGIZING THE PLC TRANSMITTER, ENSURE THE TRANSMITTER COAX (J1) IS CONNECTED TO A LOAD, EITHER THE TUNED LINE TUNING EQUIPMENT OR A 50 OR 75Ω 25W IMPEDANCE.</p>

3.7 Disconnections



CAUTION

NEVER DISCONNECT THE CARRIER LEAD-IN BETWEEN THE LINE TUNER AND THE COUPLING CAPACITOR UNLESS THE LOW POTENTIAL END OF THE COUPLING CAPACITOR IS GROUNDED. BEFORE DISCONNECTING THE CARRIER LEAD-IN CONDUCTORS, CLOSE THE GROUNDING SWITCH AT THE BASE OF THE COUPLING CAPACITOR. IF THIS GROUND IS NOT PROVIDED, DANGEROUS VOLTAGES CAN BUILD UP BETWEEN THE LINE TUNER AND COUPLING CAPACITOR.

3.8 Jumper Controls

Jumpers are set during installation, depending on the particular TCF-10B features and applications involved (see Figure 3-4).

3.8.1 Power Supply PC Board

Jumper (JU1) for the optional Alarm Relay establishes contact type during loss of power condition (NO or NC).

NOTE

JU1 is shipped in the “NC” state.

3.8.2 Keying PC Board

- JU1 Power Off (NORM or INVERT)
- JU2 Directional Comparison or Phase Comparison (DCR or PCR)
- JU3 1 W Guard, 10 W Trip or 10 W Guard, 10 W Trip (1/10 W or 10/10 W)
- JU4 2-Frequency System or 3-Frequency (Optional) System (2F or 3F)
- JU6 Activates Shift High Contact Alarm (IN or OUT)
- JU7 Activates Shift Low Contact Alarm (IN or OUT)
- JU8 Selects NO or NC contact for Shift

High (NO or NC)

- JU9 Selects NO or NC contact for Shift Low (NO or NC)

JU10–

- JU14 Input voltage selections for different Keying inputs (15 V, 48 V, 125 V, or 250 V)

3.8.3 Transmitter PC Board

DIP switch S5 sets the frequency shift as follows:

- Position 1 = 50 Hz
- Position 2 = 100 Hz
- Position 3 = 200 Hz
- Position 4 = 400 Hz

3.8.4 10W PA PC Board

Jumper (JU1) for the optional Alarm Relay establishes loss of power condition (NO or NC).

NOTE

JU1 is shipped in the “NC” state.

3.8.5 RF Interface PC Board

NOTE

JU1/JU5 are shipped in the “OUT” (4-wire) state. JU4 is shipped in the 50Ω state.

Matching Impedance Jumpers:

- JU4 50Ω
- JU3 75Ω
- JU2 100Ω

2-wire or 4-wire RF Termination:

- JU1 and JU5 “IN” (2-wire)
- JU1 and JU5 “OUT” (4-wire)

Attenuator Override Jumper (JU6):

- NORM Sensitivity (22.5mV to 70 V)
- HIGH Sensitivity (5mV to 17 V)

3.8.6 Receiver/Discriminator & CLI PC Board

Jumper J3 for low signal alarm relay establishes NO or NC; the relay is energized when a receive signal is present and above minimum sensitivity setting. The module has an eight position DIP switch. Please refer to Chap. 14 for details. The DIP switch settings are provided here for your convenience.

3.8.7 Receiver Logic PC Board

The Receiver Logic Module (style number CF20-RXLMN-00X) has no jumpers on its PC board. Instead, it provides three banks of DIP switches to control its logic functions. Each board also includes a pre-programmed, plug-in EPLD chip for one of the following types of application:

- 2-Frequency Directional Comparison
- 3-Frequency Directional Comparison
- 2-Frequency Phase Comparison

For complete information and instructions on setting the DIP switches, please refer to “Setting

Table 3-1 Universal Receiver (SW1 settings).

SWITCH SETTING	OFF	ON
SW1-1	FSK	AM
SW1-2	NO VOICE ADAPTER	VOICE ADAPTER
SW1-3	DTT (50ms D.O. on noise clamp)	UB (10 ms D.O. on noise clamp) UB 2F or 3 Frequency
SW1-4	DIRECTIONAL COMPARISON RELAYING	PHASE COMPARISON RELAYING
SW1-5	SHIFT DOWN TO TRIP 2F or 3F	SHIFT UP TO TRIP 2F only

Note: It is recommended that the Receiver Logic pre-trip time delay be for at least a minimum of 4ms, preferably at the maximum the power system will allow for critical clearing times for Direct Transfer Trip Applications. Refer to Receiver Logic Section for settings.

Table 3-2 Universal Receiver (SW1-1 set to the OFF position).

SW1-6	SW1-7	SW1-8	BANDWIDTH	SHIFT	2F/3F
OFF	OFF	OFF	380 Hz	100 Hz	2F
OFF	OFF	ON	800 Hz	250 Hz	2F
OFF	ON	OFF	1600 Hz	500 Hz	2F
OFF	ON	ON	800 Hz	250 Hz	3F
ON	OFF	OFF	1600 Hz	500 Hz	3F
ON	OFF	ON	800 Hz	100 Hz	2F
ON	ON	OFF	1600 Hz	250 Hz	2F

the DIP Switches for Your Application” in Chapter 15. For a diagrammed overview of the possible DIP switch settings and other signal flow information for each application, please refer to Figure 15-7 (2-Frequency Directional Comparison), Figure 15-8 (3-Frequency Directional Comparison), and Figure 15-9 (2-Frequency Directional Comparison).

3.8.8 EM Output Board

There are six relays on the board; six jumpers (JU1 thru JU6) determine the function of the relays. The choice of functions are:

- Guard
- Trip 1
- Trip 2
- Off

There are six additional jumpers which provide “NO” or “NC” contacts for the alarm relays as follows:

- K1 (JU7)
- K2 (JU8)
- K3 (JU9)
- K4 (JU10)
- K5 (JU11)
- K6 (JU12)

3.8.9 Voice Adapter PC Board

A jumper and a DIP switch are provided, as follows:

JMP1 Alarm Contacts (NO/NC)

When jumper is set in “NO” position, and relay is de-energized, the alarm contacts will be “OPEN”. When jumper is in “NC” position, and relay is de-energized, the alarm contacts will be “CLOSED”.

SW1 User Functions

In the closed/down position the DIP switch functions as follows;

- 1 Tone gives Alarm (TCF-10B)
- 2 Carrier gives Alarm (TC-10B)
- 3 Handset key mutes ear (TC-10B)
- 4 Beeper enabled (Both)

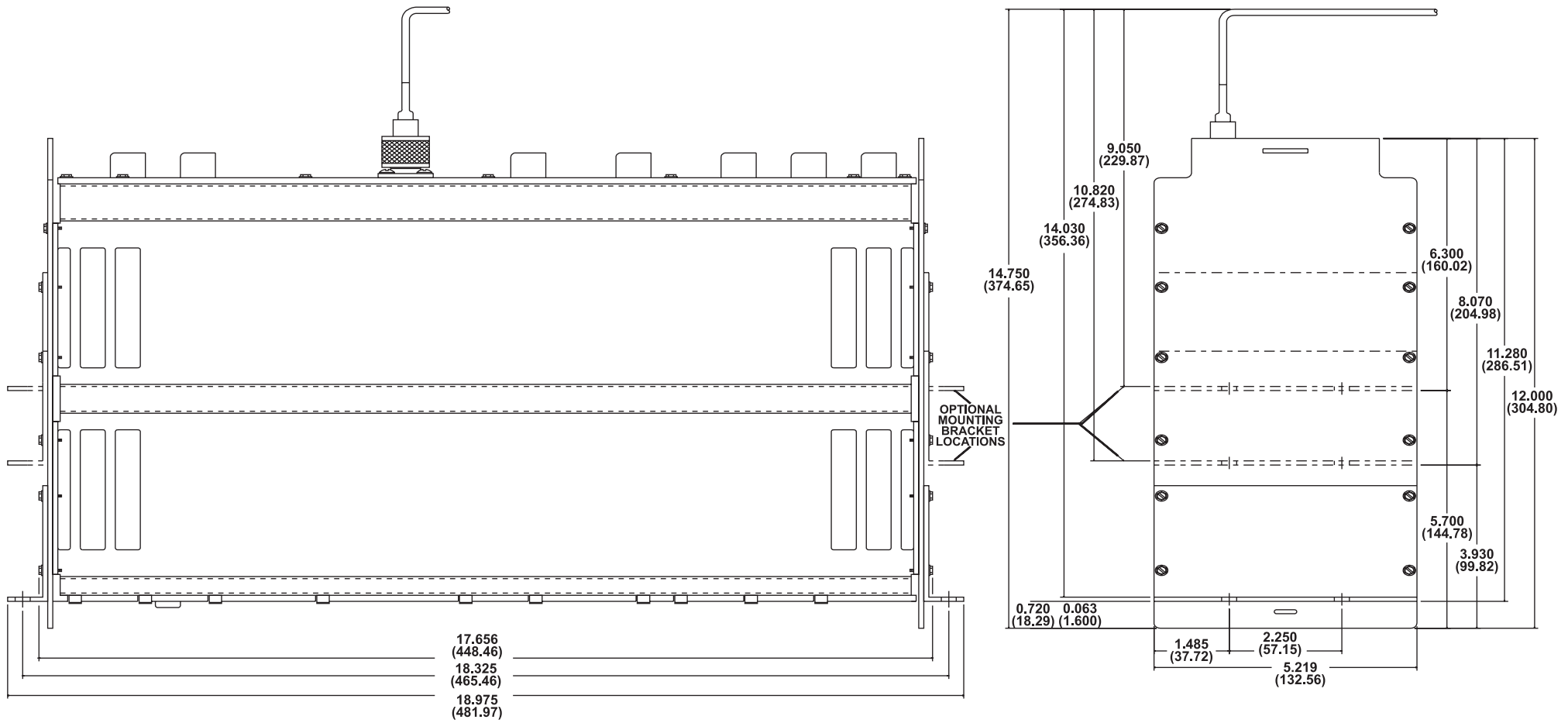
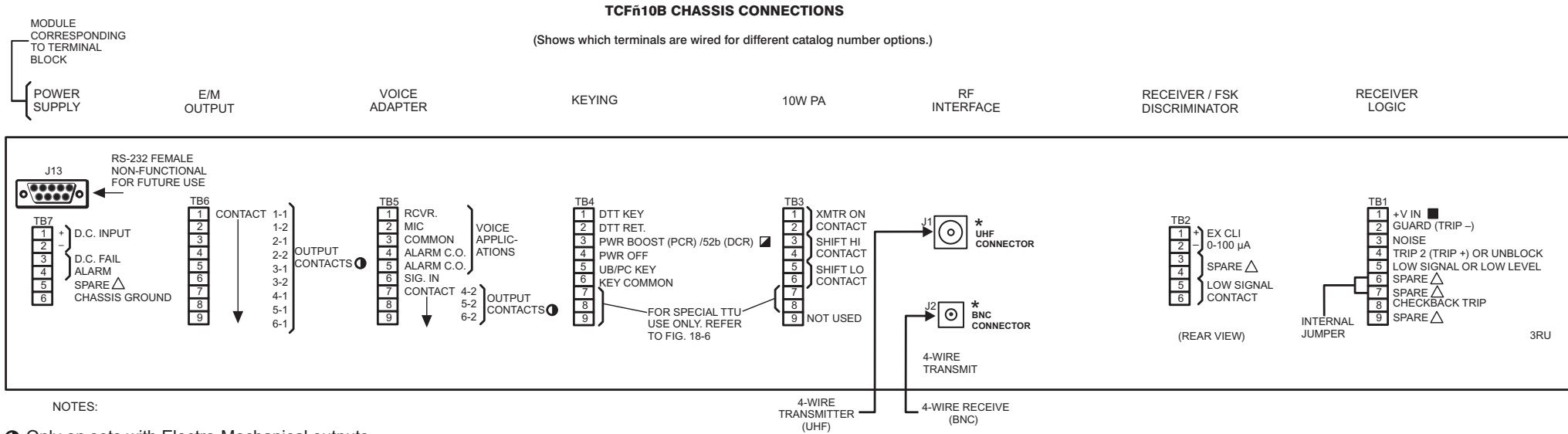

Figure 3-3. TCF-10B Mechanical Outline Drawing (1354D48).

Figure 3-4. TCF-10B Connection Drawing and Jumper Options.



Chassis Options	Module Options	Terminal Blocks Used
Transmitter Only	1. None (basic transmitter)	TB4 (1-6), TB7 (1, 2, 6), TB3 (1-6), TB7 (3, 4)
	2. Voice adapter	TB5 (1-6)
Receiver Only	1. None (basic transmitter)	TB1 (1-5, 8), TB7 (1, 2, 6), TB2 (1, 2, 5, 6), TB7 (3, 4)
	2. Voice adapter	TB1 (1-6, 8), TB7 (1, 2, 6)
	3. E/M outputs	TB6 (1-9); TB5 (7-9)
Transceiver (Transmitter and Receiver)	(Combine options from above)	(See above)

Chapter 4. Test Equipment

Table 4-1 shows the equipment you should use to perform the Acceptance Tests (Chapter 5) and Routine Adjustments (Chapter 6).

Table 4–1. Recommended Test Equipment.

Equipment	Application
High-Impedance Selective Level Meter, 380 Hz to 1 MHz (Rycom 6021A) ¹	Impedance Matching Transmitter Power Adjustment Receiver Margin Setting
Current Meter (Simpson 260) ¹	Check dc Supply
Reflected Power Meter, Auto VLF Power SWR Meter (Signal Crafter 70) ¹	Impedance Matching at Carrier Output
Oscilloscope (Tektronix) ^{1,2}	Transmitter Power Adjustment for Optional Voice Adapter Module
Frequency Counter, 80 MHz (H/P5381A) ^{1,2}	Transmitter Frequency
Non-Inductive Resistor, 50Ω, 25 W (Pacific) ¹	Transmitter Termination
Signal Generator (H/P 3325A, Signal Crafter Model 90) ^{1,2}	General ac output for lab measurements
Extender Board (1353D70G01)	(See Figure 4-1.)



CAUTION

WE RECOMMEND THAT THE USER OF THIS EQUIPMENT BECOME THOROUGHLY ACQUAINTED WITH THE INFORMATION IN THESE INSTRUCTIONS BEFORE ENERGIZING THE TCF-10B AND ASSOCIATED ASSEMBLIES. YOU SHOULD NOT REMOVE OR INSERT PRINTED CIRCUIT MODULES WHILE THE TCF-10B IS ENERGIZED. ALL INTEGRATED CIRCUITS USED ON THE MODULES ARE SENSITIVE TO AND CAN BE DAMAGED BY THE DISCHARGE OF STATIC ELECTRICITY. YOU SHOULD ALWAYS OBSERVE ELECTROSTATIC DISCHARGE PRECAUTIONS WHEN HANDLING MODULES OR INDIVIDUAL COMPONENTS. FAILURE TO OBSERVE THESE PRECAUTIONS CAN RESULT IN COMPONENT DAMAGE.

¹ Indicates “or equivalent” of the recommended equipment item.

² Required only for the design verification test in Chapter 7.

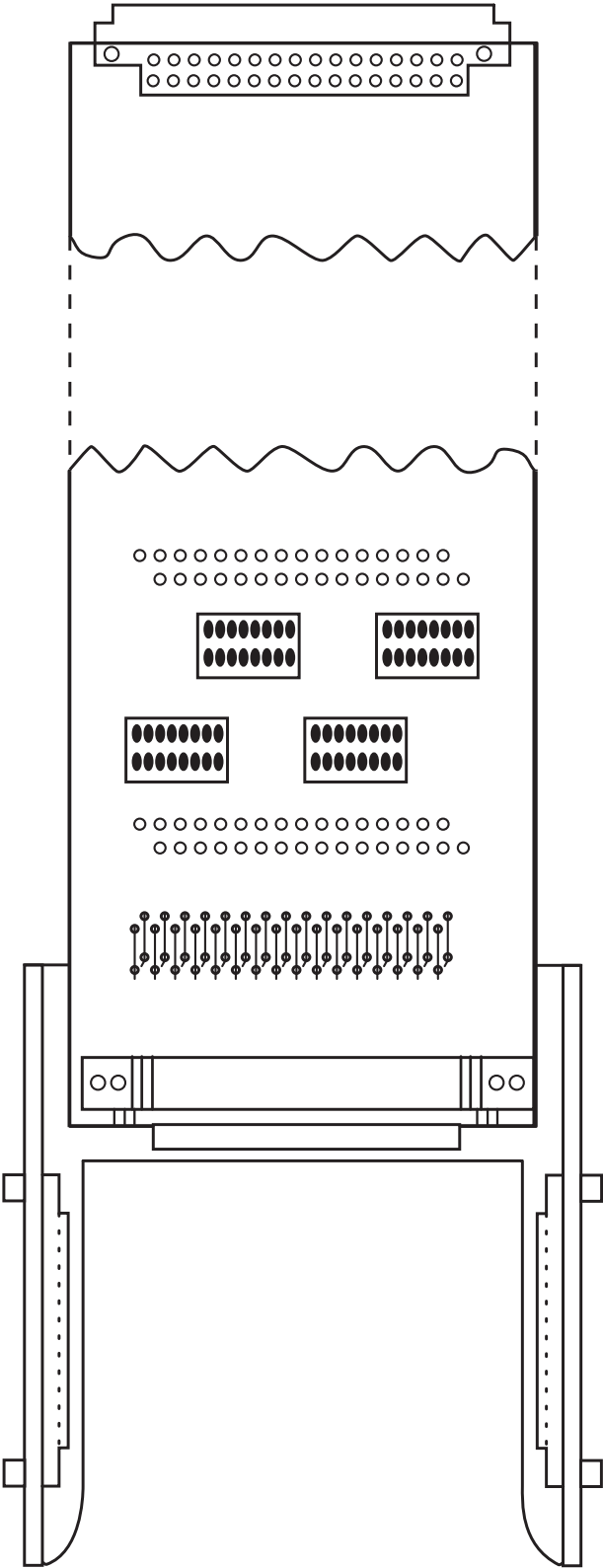

Figure 4-1. Extender Board.

Chapter 5. Installation/Adjustment Procedures

You perform routine adjustments in the field for the following purposes:

- Verifying initial TCF-10B factory adjustments.
- Adapting the TCF-10B to your application.
- Setting the TCF-10B operating frequencies.
- Periodic maintenance.

Be sure to run the adjustment tests in the following order:

1. Select the TCF-10B Center Frequency.
2. Review the Adjustment Data Sheets (at the end of this chapter); you should complete the data sheets as you perform the Adjustment Steps.
3. Select the TCF-10B Keying Conditions.
4. Select the TCF-10B Receiver Logic.
5. Select the TCF-10B Transmitter RF Output Impedance.
6. Check the Line Tuning and Matching Equipment.
7. Check the TCF-10B Transmitter Power Levels and Frequency.
8. Set the TCF-10B margin and Internal and External CLI Settings.
9. Check the TCF-10B Receiver Margin.

To prepare the TCF-10B for the routine adjustment tests, perform the following:

- Review the Test Equipment (Chapter 4).
- Review the Adjustment Data Sheets (at the end of this chapter); you should complete the data sheets as you perform the Adjustment Steps.
- Review the TCF-10B Block Diagram as described under Signal Path (Chapter 6).
- Remove the cover from the front of the chassis. After removing the cover, set it in a safe place.



CAUTION

MAKE SURE THAT THE POWER HAS BEEN TURNED "OFF" USING THE POWER SWITCH (S1) ON THE POWER SUPPLY MODULE; THE INPUT (D3) AND OUTPUT (D11) LEDS SHOULD NOT SHOW RED LIGHTS.

If you are using the optional Alarm Relay, set jumper JU1 on the Power Supply Module.

Connect the system in accordance with the connection diagram(s), at end of the Installation section.

5.1 Select TCF-10B Center Frequency and Shift

5.1.1 Transmitter Operating Frequencies

If the Transmitter Module is supplied with the TCF-10B set, remove it from the TCF-10B chassis and select the operating frequencies.

1. Using the module extractors, remove the Transmitter Module.
2. Select the Transmitter center frequency (between 30 and 535 kHz) by turning the four Transmitter rotary programming switches (in 0.1 kHz steps) with a small screwdriver until the desired frequency appears in the (four) windows of the Transmitter Control Panel.
3. Set switch S5 for the appropriate frequency shift, as shown in the following table.
4. Insert the module back into the TCF-10B chassis by seating it with firm pressure.

Frequency Shift Settings	Position Settings				Shift
	1	2	3	4	
Narrow Band, Narrow Shift	Up	Dwn	Up	Up	100 Hz
Wide Band, Narrow Shift	Up	Dwn	Up	Up	100 Hz
Wide Band, Wide Shift	Dwn	Up	Dwn	Up	250 Hz
Extra Wide Band, Wide Shift	Up	Dwn	Up	Dwn	500 Hz

5.1.2 Receiver Center Frequency

If a Receiver Module is supplied with the TCF-10B set, power up the TC-10B unit with the appropriate dc power. With a small screwdriver, depress the "SET" button on the front of the receiver module. The frequency display will begin to flash. Depress the raise or lower button until the desired frequency is displayed. Depress "SET" again to select this frequency. If you are *not* ready to set the sensitivity, depress the "CANCEL" button. If you *are* ready to set the sensitivity, depress the "SET" button and proceed with the steps listed in Section 5.7.

5.2 Select TCF-10B Keying Conditions

5.2.1 Test Switches

Three push-button switches are provided for test purposes:

- S1 High-Level Power (HL)
- S2 Shift High (SH)
- S3 Shift Low (SL)

Each push-button is recessed, and can be activated by sliding an object (e.g., a pen or pencil) through each push-button access location on the Keying Module front panel.

5.2.2 Keying Module LEDs

The LEDs at the bottom of the Keying Module front panel indicate the Keying condition:

- HL High-Level Key Output
- SL Shift High Key Output
- SH Shift Low Key Output
- V Voice-Level Key Output
- TX Any Transmitter Key Output

5.2.3 Keying Module Jumpers

Remove the Keying Module from the chassis and set jumpers (JU1 thru JU14) as desired.

- JU1 Allows you to select between the NORM/INVERT positions for Power Off. Select the normal (NORM) position to allow a Keying function in the transmitter when proper voltage level (15V, 48V, 125V, 250V) is applied to the input terminals. Select the invert (INV) position to allow a Keying function in the Transmitter when voltage is not present at the input terminals. Set JU1 to invert (INV).
- JU2 Selects between a Directional Comparison system and Phase Comparison system. Set JU2 to DCR (Directional Comparison).

JU3 This link allows you to select between a 1W (Guard)/10W (Trip) or 10W (Guard)/10W (Trip) operation by placing the link in the 1/10W or 10/10W position, respectively. Select the 1W/10W position.

JU4 Selecting the 2-frequency (2F) position will set the Keying Module as a two-frequency system. Selecting the three-frequency (3F) position will set the Keying Module in mode to correctly operate as a three-frequency system. Select the 3F position.

JU6 Placing JU6 to the IN position activates the shift high contact; the OUT position deactivates the shift high contact.*

JU7 Placing JU7 to the IN position activates shift low contact; the OUT position deactivates shift low contact.*

JU8 Places shift high contacts in either the normally open (NO) position or the normally closed (NC) position.

JU9 Places shift low contacts in either the normally open (NO) position or the normally closed (NC) position.

JU10-

JU14 Provides input keying voltage selections: 15/20V, 48V, 125V, 250V.

After setting the jumpers, insert the Keying Module back into the TCF-10B chassis.

5.3 Select TCF-10B Receiver Logic

Set the Receiver Logic PC Board switches (see Section 15.3) in accordance with the TCF-10B application:

- 2-Frequency, Directional Comparison
- 2-Frequency, Phase Comparison
- 3-Frequency, Directional Comparison

**Place in the "OUT" position when using with the Phase Comparison relay systems.*

5.4 Select TCF-10B Transmitter RF Output Impedance

1. Configure the RF Output Impedance.

Remove the RF Interface Module from the TCF-10B chassis and configure the output impedance by setting jumpers:

- JU4 when set, provides 50Ω
- JU3 when set, provides 75Ω
- JU2 when set, provides 100Ω

2. Select 2- or 4-wire Receiver Input, using jumpers JU1 and JU5:
 - IN position for 2-wire (not normally used for TCF-10B)
 - OUT position for 4-wire (both JU1 and JU5 must be OUT)
3. If you are using an external hybrid chain, and the receive signal is not high enough, a higher sensitivity may be desirable. Set jumper JU6 to HIGH, if necessary.
4. Insert the RF Interface Module back into the TCF-10B chassis.

5.5 Check Line Tuning and Matching Equipment

1. Refer to the appropriate instructions for line tuning equipment.



CAUTION

DO NOT ALLOW INEXPERIENCED PERSONNEL TO MAKE THESE ADJUSTMENTS. PERSONNEL MUST BE COMPLETELY FAMILIAR WITH THE HAZARDS INVOLVED.

2. Perform the required adjustments.

5.6 Check TCF-10B Transmitter Power Levels and Frequency

Turn “ON” the power and check the dc voltage outputs from the Power Supply Module. Then, turn “OFF” the power and remove the coaxial cable connection to the Line Tuner and substitute a 50, 75, or non-inductive 100Ω resistor termination (in accordance with the jumper settings in 5.4-1).

5.6.1 Check High-Level Output

1. Connect the Selective Level Meter to the 10W PA Module control panel, at test jacks:

TJ1 Input - Top Jack

TJ2 Common - Bottom Jack

2. Tune the meter to the Transmitter frequency.
3. Turn power “ON” at the Power Supply Module.
4. On the Keying Module control panel, press and hold the top push-button (marked HL) to key the Transmitter at High Level power.

The “HL” and “TX” LEDs should show red.

5. Record the Selective Level Meter reading (at TJ1, TJ2). The meter should measure .224 Vrms (0 dBm at 50Ω reference) for full High-Level keying (10W power). If you measure 0 dBm, skip ahead to Step 8.
6. If the meter does not measure 0 dBm, turn the power “OFF” at the Power Supply Module and remove the Transmitter Module from the chassis. Place the extender board into the Transmitter Module position of the chassis. Then plug the Transmitter Module onto the extender board.

- Turn the Power Supply “ON”. Turn the 10W Adjust potentiometer R13 on the Transmitter Module until the Selective Level Meter (at the 10W PA TJ1, TJ2) reads .224Vrms (0 dBm at 50Ω reference). Then place the Transmitter Module back in the chassis.

If it is desirable to set full power at less than 10W, turn the 10W adjust potentiometer (R13) accordingly. The level at the RF Interface Module (TJ1, TJ2) is 40 dB higher than at the 10W PA Module (TJ1, TJ2).

For example: If 22 dBm is desired at RF Interface(TJ1, TJ2), set potentiometer R13 so that 10W PA (TJ1, TJ2) reads -18 dBm. (The PA gain is adjustable with R53 on the 10W PA Module.)

- Monitor the output of the 10W PA Module at the RF Interface Module test jacks TJ1 (Line)/TJ2 (Line Common). On the 10W PA Module, adjust potentiometer R53 INPUT LEVEL SET for 22.4Vrms (10W) output level.
- On the Keying Module control panel, release the (HL) push-button to reduce the Transmitter power.

The “HL” LED should not be red; but the “TX” LED should remain red.

5.6.2 Check Low-Level Output

- With the conditions the same as for the High-Level Output check:
 - Selective Level Meter at the 10W PA Module control panel (TJ1, TJ2)
 - Meter tuned to XMTR frequency
 - Power “ON”

The “TX” LED should show red.
- With the Transmitter keyed on LL, record the Selective Level Meter reading (at TJ1, TJ2). The meter should measure .0707Vrms (-10 dBm at 50Ω reference) for Low-Level keying (1W power).
- If the meter does not measure -10 dBm, turn the power “OFF” at the Power Supply Module

and remove the Transmitter Module from the chassis. Place the extender board into the Transmitter Module position of the chassis. Then plug the Transmitter Module onto the extender board.

- Turn the 1W Adjust potentiometer (R12) on the Transmitter Module until the Selective Level Meter (at the 10W PA TJ1, TJ2) reads .0707Vrms (-10 dBm at 50Ω reference).
- Repeat step 5.6.1-8 (above) at 7.07Vrms (1W) output level.
- Turn “OFF” the power supply.
- Place the Transmitter Module back in the chassis.

We recommend that you set the low level power 10 dB below full power. You may, however, use any power level between 10W and 50mV.

5.6.3 Adjusting Low-Level Output for a Level Other Than 1W

Should you wish to adjust the low-level output for a level other than 1W, use R12 on the transmitter card to adjust to the level you desire. The following chart gives you several levels that you may use for reference.

Desired Power Output (Watts)	Reading at 10W PA TJ1, TJ2 (V rms)
0.5	0.05
1.5	0.0866
2.0	0.10
2.5	0.112
5	0.158
10	See Note

For a 10W low-level output, it is easier to move jumper JU3 on the keying module to the 10/10W position.

5.6.4 Check Voice-Level Output

Perform this procedure only if you are using the Voice Level Output option.

1. With the conditions the same as for the High-Level Output check:
 - Selective Level Meter at the 10W PA Module control panel (TJ1, TJ2)
 - Meter tuned to XMTR frequency
 - Power “ON”
2. Key the carrier set by lifting the handset from its cradle, while muting the microphone, to key the Transmitter at Voice-Level (4.3W power, when the High-Level power is set to 10W).

The “V” and “TX” LEDs should show red.

3. Record the Selective Level Meter reading (at TJ1, TJ2). The meter should measure .148 Vrms (-3.6 dBm at 50Ω reference) for Voice Keying. If you measure -3.6 dBm, skip ahead to Step 6.
4. If the meter does not measure -3.6 dBm, turn the power “OFF” at the Power Supply Module and remove the Transmitter Module from the chassis. Place the extender board into the Transmitter Module position of the chassis. Then plug the Transmitter Module onto the extender board.
5. Turn the Voice Carrier Adjust potentiometer (R14) on the Transmitter Module until the Selective Level Meter (TJ1, TJ2) reads .148 Vrms (-3.6 dBm at 50Ω reference). Then place the Transmitter back in the chassis.
If using a full power level (other than 10W), you should set the VF level accordingly, i.e., 3.6 dB below the high-level value.
6. Monitor the output of the carrier set with an oscilloscope at the 10W PA Module test jacks:
 - TJ1
 - TJ2
7. Voice key the Transmitter by lifting the handset from its cradle and by whistling loudly (about 1 kHz) to achieve the following voltages:
 - ~ .62V p-p (overall)
 - ~ .20V p-p (valley)

8. If the voltages above (.62/.20) do not approximate a ratio value of 3, adjust the AM Modulation Adjust potentiometer (R11) on the Transmitter, as follows:
 - Clockwise if not enough signal (a value less than 3).
 - Counterclockwise if too much signal (a value significantly greater than 3).
9. Un-key the Push-to-Talk switch (or handset).

5.6.5 Check Transmitter Frequency

1. At the Keying Module, push the recessed push-button “SH” to shift the frequency higher: (f_C = center freq. set on front of module)

$f_C + 100$ Hz Narrow Band or Wide Band, Narrow Shift

$f_C + 250$ Hz Wide Band, Wide Shift

$f_C + 500$ Hz Extra Wideband, Wide Shift

If the frequency shift is incorrect on the Transmitter Module, check the position of switch S5 for the correct amount of shift.

2. At the Keying Module, release the “SH” push-button and push the “SL” push-button to shift the frequency lower:

$f_C - 100$ Hz Narrow Band or Wide Band, Narrow Shift

$f_C - 250$ Hz Wide Band, Wide Shift

$f_C - 500$ Hz Extra Wideband, Wide Shift

If the frequency is incorrect on the Transmitter Module, check the position of switch S5 for the correct frequency. Release push-button “SL”.

5.6.6 Restore Transmitter Module to Normal

1. Turn the power “OFF” at the Power Supply Module.
2. Remove the 50, 75, or 100Ω resistor termination and replace the coaxial cable connection to the Line Tuner.
3. Move the Selective Level Meter to test jacks marked “LINE” (on the RF Interface control panel):
 - TJ1 (Line)
 - TJ2 (Common)
4. Turn the power “ON” at the Power Supply Module.
5. On the RF Interface Module, configure output impedance by setting a jumper. The Selective Level Meter (TJ1, TJ2) should show a maximum reading (Vrms) for 1W (+30 dBm) power, as follows:

JU4	When set, provides 50Ω (7.07Vrms)
JU3	When set, provides 75Ω (8.6Vrms)
JU2	When set, provides 100Ω (10.0Vrms)

NOTES:

1. The foregoing procedure adjusts the Receiver margin to the recommended 15 dB value.
2. The Receiver bar graph CLI meter reading should be 0 dB at this time.
3. In three-terminal line applications, the margin adjustment procedure should use the weaker of the two received signals.
4. When applying the TCF-10B with a phase comparison relay, do not readjust the Receiver level when keying with a square wave signal. The CLI will read around -10 dB, but this is an average reading of the on and off square wave. The receiver will still maintain the 15 dB margin. The CLI reading is only accurate for a non-amplitude modulated signal.

6. If the above (Vrms) values are not achieved, recheck the tuning of the coupling system, as it is not presenting the Transmitter with the proper termination.

5.7 Check TCF-10B Receiver Margin Setting using Remote Carrier Signal

1. At the Power Supply Module, turn the power “ON”. If the frequency is not already set, refer to section 5.1.2.
2. Arrange for a received signal from the remote end,
3. Sensitivity setting:

On the Receiver module to complete the setting:

- a) Hit “SET” twice until the display reads “SET SENS?”
 - b) With the remote signal being received (at the remote end, push the “LL button on the keying module), depress “SET” again.
 - c) If you’re not adjusting the 15 dB margin, depress “SET” again. If you are, then depress “RAISE” or “LOWER” as required to adjust it up or down 5 dB.
 - d) If you are not going to adjust an external carrier level meter, depress “SET”. Otherwise, press “RAISE” or “LOWER” as required.
4. Set the external CLI.

Once you have completed the sensitivity setting, the display scrolls this message: "Set Ext CLI? – Hit Raise/Lower or Set when done..."

To calibrate the external CLI push the CANCEL/RAISE or LOWER button. The external CLI meter will move up and down accordingly. The external meter is a 100μA instrument. If it is calibrated in μA, the meter should be set to read 67μA (this is equivalent to 0 dB on the internal meter). The setting should vary 3.3μA for each dB the margin adjustment has been raised or lowered from the 15 dB margin. If the meter is calibrated in

dB, set the meter to read equal to the internal CLI meter.

To accept the displayed level, push the SET button.

This completes the Receiver setting procedure.

5.8 Prepare the TCF-10B for Operation

Be sure that power is "ON" at the Power Supply Module.

1. Restore the Keying Module to the desired settings. (See the TCF-10B Adjustment Data Sheet near the end of this chapter. This data sheet is to be completed by your settings department.)
2. Replace the cover on the TCF-10B control panel.
 - a) Secure the latch by pushing inward and sideways until the cover is secure.
 - b) You may lock the latches into place using meter seals.

This completes the "Routine Adjustment" procedure. The TCF-10B is ready to be put into operation.

NOTE

When placing the TCF-10B into service, refer to the manual for the relay system you are using with the TCF-10B System.

TCF-10B ADJUSTMENT DATA SHEET

(1) Power Supply	<u>Test Jack</u>	
+20 Vdc	(+20V/Comm)	_____
-20 Vdc	(-20V/Comm)	_____
Input & Output LEDs "ON"	—	_____
(2) 10W PA		
Voice PA "IN"	(Input/Common)	_____
LLPA "IN"	(Input/Common)	_____
HLPA "IN"	(Input/Common)	_____
Transmit LED "ON"	—	_____
(3) RF Interface		
XMTR Frequency, Shift High	(Line/Line Com)	_____
XMTR Frequency, Shift Low	(Line/Line Com)	_____
XMTR Frequency, Center Freq.	(Line/Line Com)	_____
Voice Level (if using a voice adapter)	(Line/Line Com)	_____
LL Level (guard)	(Line/Line Com)	_____
HL Level	(Line/Line Com)	_____
Received Frequency, Shift High	(RCVR/RCVR Com)	_____
Received Frequency, Shift Low	(RCVR/RCVR Com)	_____
Received Frequency, Center Freq.	(RCVR/RCVR Com)	_____
Received Level	(RCVR/RCVR Com)	_____
Received Noise Level, w/Rem Transmitter off . . .	(RCVR/RCVR Com)	_____
 (note bandwidth of meter when measuring noise level)		

(4) Receiver/Discriminator (from other end)

- bar graph meter w/LL Keyed(dB) _____
- bar graph meter w/HL Keyed(dB) _____
- Noise LED Not Lit - _____
- Low-Level LED Not Lit - _____

(5) Receiver Logic

- (a) 2 Frequency
 - Good Channel LED _____
 - Checkback Trip LED _____
 - Trip LED _____
 - Guard LED _____
- (b) 3 Frequency Logic
 - Good Channel LED _____
 - Checkback Trip LED _____
 - UB/POTT Trip LED _____
 - DTT Trip LED _____
 - Guard LED _____
- (c) Phase Comparison
 - Good Channel LED _____
 - Trip Positive LED _____
 - Trip Negative LED _____

(6) Rear of Chassis

- Reflected Power(J1) _____ (%)

Test Performed By _____ **Date** _____

TCF-10B JUMPER & SWITCH SETTINGS

(1) POWER SUPPLY

JU1 Power Alarm NO___ NC___

(2) KEYING

JU1 Power On/Off NORM___ INV___

JU2 Directional Comparison/
Phase Comparison DCR___ PC___

JU3 1W Guard, 10W Trip or
10W Guard – 10W/Trip 1 W/10 W___ 10 W/10 W___

JU4 2-Frequency or 3-Frequency 2F___ 3F___

JU6 Shift High Contacts IN___ OUT___

JU7 Shift Low Contacts IN___ OUT___

JU8 NO or NC for Shift High NO___ NC___

JU9 NO or NC for Shift Low NO___ NC___

JU10 DTT Keying Voltage 15V___ 48V___ 125V___ 250V___

JU11 Ext. Voice Keying Logic 15V___ 48V___ 125V___ 250V___

JU12 PWR Boost/52b Keying
Voltage 15V___ 48V___ 125V___ 250V___

JU13 Power Off Keying Voltage 15V___ 48V___ 125V___ 250V___

JU14 UB, POTT, PC Keying
Voltage 15V___ 48V___ 125V___ 250V___

(3) TRANSMITTER

S5 Frequency-Shift Select (Down = Selected)

Position	Up	Down
1 (50 Hz)		
2 (100 Hz)		
3 (200 Hz)		
4 (400 Hz)		

(4) 10W POWER AMPLIFIER

JU1 Power Monitor NO___ NC___

(5) RF INTERFACE

JU1 2-Wire/4-Wire (2-wire) IN___ (4-wire) OUT___

JU2 Impedance-100Ω IN___ OUT___

JU3 Impedance- 75Ω IN___ OUT___

JU4 Impedance- 50Ω IN___ OUT___

JU5 2-Wire/4-Wire (2-wire) IN___ (4-wire) OUT___

JU6 Sensitivity HIGH___ NORM___

(6) RECEIVER MODULE

FSK Receiver (TCF-10B):

Dip Switch (SW 1)		OPEN (Down or Off)			Closed (Up or On)	
Pos 1		X FSK			___ ON/OFF	
Pos 2		___ No voice			___ Voice	
Pos 3		___ DTT 2F			___ 3F or UB 2F	
Pos 4		___ DCR			___ PCR	
Pos 5		___ Shift down to trip			___ Shift up to trip*	
FSK	Bandwidth	Shift	2F/3F	Pos 6	Pos 7	Pos 8
___	300	100	2F	OFF	OFF	OFF
___	600	250	2F	OFF	OFF	ON
___	1200	500	2F	OFF	ON	OFF
___	600	250	3F	OFF	ON	ON
___	1200	500	3F	ON	OFF	OFF
___	600	100	2F	ON	OFF	ON
___	1200	250	2F	ON	ON	OFF

JU3 !Low Signal Contact ___NO ___NC

*2F Only
! = Inverted

(7) **RECEIVER LOGIC** - for information on the settings, please see Chapter 16

CF20-RXLMN-004: 2-FREQUENCY DIRECTIONAL COMPARISON LOGIC

	OPEN (OFF)	CLOSED (ON)	
SW1-1			TRIP DELAY
SW1-2			
SW1-3			
SW1-4			
SW1-5			TRIP HOLD TIMER
SW1-6			
SW1-7			GUARD HOLD TIMER
SW1-8			

	OPEN (OFF)	CLOSED (ON)	
SW2-1			UNBLOCK TIME
SW2-2			
SW2-3			NOISE ALLOWS UB TRIP
SW2-4			GUARD BEFORE TRIP OPTIONS
SW2-5			
SW2-6			NOT USED
SW2-7			
SW2-8			

	OPEN (OFF)	CLOSED (ON)	
SW3-1			NOT USED
SW3-2			
SW3-3			
SW3-4			
SW3-5			
SW3-6			LOW LEVEL DELAY
SW3-7			
SW3-8			

CF20-RXLMN-002: 3-FREQUENCY DIRECTIONAL COMPARISON LOGIC

	OPEN (OFF)	CLOSED (ON)	
SW1-1			UB/POTT TRIP DELAY
SW1-2			
SW1-3			
SW1-4			
SW1-5			TRIP HOLD
SW1-6			
SW1-7			GUARD HOLD
SW1-8			

	OPEN (OFF)	CLOSED (ON)	
SW2-1			UNBLOCK TIME
SW2-2			
SW2-3			NOISE ALLOWS UB TRIP
SW2-4			GUARD BEFORE TRIP OPTIONS
SW2-5			
SW2-6			DTT TRIP DELAY
SW2-7			
SW2-8			
SW3-1			TRIP HOLD
SW3-2			
SW3-3			
SW3-4			GUARD HOLD
SW3-5			
SW3-6			CHECKBACK #1 or #2
SW3-7			LOW LEVEL DELAY
SW3-8			

CF20-RXLMN-003: 2-FREQUENCY PHASE COMPARISON LOGIC

	OPEN (OFF)	CLOSED (ON)	
SW1-1			— 2 FREQUENCY / 3 FREQUENCY
SW1-2			— POLARITY
SW1-3			— SKBU / SPCU

(8) VOICE ADAPTER

JMP1 _____NO _____NC

SW1 (Function active when in "ON" position)

POS 1 - Front Panel push-button gives alarms at opposite end TCF-10B

POS 2 - Carrier Alarm (TC-10B)

POS 3 - Push to talk function (TC-10B)

POS 4 - Beeper enabled (Both)

(9) EM (RELAY) OUTPUT

JU1	Relay 1 Driver	Trip 1 (DTT for 3F)_____	Trip 2 (UB/POTT, 3F)_____	Guard_____
JU2	Relay 2 Driver	Trip 1 (DTT for 3F)_____	Trip 2 (UB/POTT, 3F)_____	Guard_____
JU3	Relay 3 Driver	Trip 1 (DTT for 3F)_____	Trip 2 (UB/POTT, 3F)_____	Guard_____
JU4	Relay 4 Driver	Trip 1 (DTT for 3F)_____	Trip 2 (UB/POTT, 3F)_____	Guard_____
JU5	Relay 5 Driver	Trip 1 (DTT for 3F)_____	Trip 2 (UB/POTT, 3F)_____	Guard_____
JU6	Relay 6 Driver	Trip 1 (DTT for 3F)_____	Trip 2 (UB/POTT, 3F)_____	Guard_____

JU7 Relay 1 Contact NO_____ NC_____

JU8 Relay 2 Contact NO_____ NC_____

JU9 Relay 3 Contact NO_____ NC_____

JU10 Relay 4 Contact NO_____ NC_____

JU11 Relay 5 Contact NO_____ NC_____

JU12 Relay 6 Contact NO_____ NC_____

***JU13** Trip Delay—_____

***JU14** Trip Delay—_____

* On 1606C53G02 only

Chapter 6. Signal Path

The following description of the TCF-10B signal path is in accordance with the Functional Block Diagram (see Figure 6-1), and the rear panel previously shown (in Figure 3-1). The discussion of signal path may be useful during Design Verification Testing (Chapter 7) or Installation/Adjustment (Chapter 5).

6.1 Power Supply Module

Terminal Block (TB7)

- TB7/1 Positive Vdc (also pins C/A-12)
- TB7/2 Negative Vdc (also pins C/A-14)
- The Vdc is received from three (3) available groups of station batteries:
- 38–70 Vdc (48 or 60 Vdc nominal)
 - 88–140 Vdc (110 or 125 Vdc nominal)
 - 176–280 Vdc (220 or 250 Vdc nominal)
- TB7/3 Failure Alarm Signal (also pins C/A-16)
- TB7/4 Failure Alarm Signal (also pins C/A-18)
- TB7/5 Spare
- TB7/6 Chassis Ground

Voltage Output to All Other Modules

Positive voltage outputs (+20 Vdc) are available at pins A-2 and A-4, while negative voltage outputs (-20 Vdc) are available at pins C-2 and C-4. Common to ground (pins C/A-30 and C/A-32).

Optional low-voltage power alarm relay outputs

Optional low-voltage power alarm relay outputs are available at pins C/A-16 and C/A-18.

6.2 Keying Module

Voltage Inputs

- +20 Vdc Pins A-2 and A-4
- 20 Vdc Pins C-2 and C-4
- Common Pins C/A-30 and C/A-32

Terminal Block (TB4)

- TB4/1 DTT (Direct Transfer Trip) Key (to pin A-10)
- TB4/2 DTT Return (to pin C-10)
- TB4/3 52b or Pwr Boost (to pin C-16)
- TB4/4 Pwr Off (to pin A-16)
- TB4/5 UB (Unblock)/PC (Phase Comparison) Key (to pin A-22)
- TB4/6 Key Common return for Power Boost, Power Off, and UB/PC key (to pin C-22)

Inputs

- External Voice Key (pins C/A-12)
- Optional Voice Key (pin C-24)

Outputs to Transmitter Module

- Shift Low (pin A-28)
- Shift High (pin A-26)
- High-Level 10W Key (pin A-8)
- Voice Key (pin A-6)
- Any Transmitter Key (pin C-6)

Outputs to 10W PA Module

- Contact Shift Low (pins C/A-20)
- Contact Shift High (pins C/A-14)

Output to Receiver Module

Any Transmitter Key (pin C-6)

6.3 Transmitter Module

Voltage Inputs

+20 Vdc Pins A-2 and A-4
 -20 Vdc Pins C-2 and C-4
 Common Pins C/A-30 and C/A-32

Inputs from Keying Module (4V Standby, 19V Keyed)

- Shift Low (pins C/A-24)
- Shift High (pin C-10)
- High-Level (10W) Key (pins C/A-8)
- Voice Key (pins C/A-6)
- Any Transmitter Key (pin A-10)

Input from Optional Voice Adapter Module

AM Voice (pin C/A-26)

Output to 10W PA Module

0 dBm for 10W or -10 dBm for 1W
 Transmitter output power (pins C/A-28)

6.4 10W PA Module

Voltage Inputs

+20 Vdc Pins A-2 and A-4
 -20 Vdc Pins C-2 and C-4
 Common Pins C/A-30 and C/A-32

Terminal Block (TB3)

TB3/1 TX (Transmitter) ON (pins C/A-12)
 TB3/2 TX (Transmitter) ON (pins C/A-14)
 TB3/3 Contact 1 Shift High, to alarms
 TB3/4 Contact 2 Shift High, to alarms
 TB3/5 Contact 1 Shift Low, to alarms
 TB3/6 Contact 2 Shift Low, to alarms

Input from Transmitter Module

0 dBm for 10W output or -10 dBm for 1W
 output (pins C/A-28)

Output to RF Interface Module

1W, voice or 10W (pins C/A-16 and C/A-18)

6.5 RF Interface Module

Voltage Inputs

+20 Vdc Pins A-2 and A-4
 -20 Vdc Pins C-2 and C-4
 Common Pins C/A-30 and C/A-32

Input from 10W PA Module

1W, voice, or 10W (pins C/A-16 and C/A-18)

Output to Receiver Module

RF Output Signal (pins C/A-28)

Other Outputs

- 1) Cable Jacks
 - J1-RF Interface module (C/A-12 and C/A-10) Transmitter RF output line, through coaxial cable (UHF)
 - J2-RF Interface module (C/A-24 and C/A-22) Receiver RF input line coaxial cable (BNC)

2) Jumpers

- JU1 UHF Chassis Ground (for J1, not supplied)
- JU2 BNC Chassis Ground (for J2, not supplied)

6.6 Receiver/Discriminator Module

Voltage Inputs

- +20 Vdc Pins A-2 and A-4
- 20 Vdc Pins C-2 and C-4
- Common Pins C/A-30 and C/A-32

Input from Keying Module

Any Transmitter Key (pin C-6)

Input from RF Interface Module

RF Output Signal (pin C-28)

Output to Discriminator and CLI Module

20 kHz signal (pin A-28)

RF Output to Optional Voice Adapter

- 20 kHz signal through jumper JU4
- 5.02 MHz signal through jumper JU3

Terminal Block (TB2)

- TB2/1 Optional External CLI Meter (pins C/A-12)
 - TB2/2 Optional External CLI Meter (pins C/A-14)
 - TB2/3 Noise + (pins C/A-16)
 - TB2/4 Noise - (pins C/A-18)
 - TB2/5 !Low Signal Contact (pins C/A-20)
 - TB2/6 !Low Signal Contact (pins C/A-22)
- !Low Signal = Not Low Signal

Output to Receiver Logic Module

- Level (pin C-28)
- High/Low Frequency (pin A-28)

- Center Frequency (pin A-10)
- Noise (pin A-8)

6.7 Receiver Logic Module

Voltage Inputs

- +20 Vdc Pins A-2 and A-4
- 20 Vdc Pins C-2 and C-4
- Common Pins C/A-30 and C/A-32

Input from CLI/Discriminator Module

- Level (pins C/A-26)
- High/Low Frequency (pins C/A-28)
- Center Frequency (pin C-10)
- Noise (pin C-8)

Terminal Block (TB1)

- TB1/1 + V Input from pins C/A-12
 - TB1/2 Guard or Trip Negative from pins C/A-14
 - TB1/3 Noise from pins C/A-16
 - TB1/4 Trip 2, Trip Positive or Unblock from pin C-18
 - TB1/5 !Low Signal* or !Low Level* from pin C-20
 - TB1/6 Common from pin C-22
 - TB1/7 Common from pin A-22
 - TB1/8 Checkback Trip from pin A-20
 - TB1/9 Unused
- *! Low Signal means Not Low Signal
! Low Level means Not Low Level

Output to EM Output Module

- Trip 1/Trip 2 (pin A-24)
- Guard (pin C-24)

6.8 EM Output Module

Voltage Inputs

- +20 Vdc Pins A-2 and A-4
- 20 Vdc Pins C-2 and C-4
- Common Pins C/A-30 and C/A-32

Input from Receiver Logic Module

- Trip 1/Trip 2 (pin C-20)
- Guard (pin A-20)

Terminal Block (TB6)

- TB6/1 Contact 1-1 from pin A/C-8
- TB6/2 Contact 1-2 from pin A/C-10
- TB6/3 Contact 2-1 from pin A/C-12
- TB6/4 Contact 2-2 from pin A/C-14
- TB6/5 Contact 3-1 from pin A/C-16
- TB6/6 Contact 3-2 from pin A/C-18
- TB6/7 Contact 4-1 from pin C-22
- TB6/8 Contact 5-1 from pin C-24
- TB6/9 Contact 6-1 from pin C-26

Output to Optional Voice Adapter Module

- Contact 4-2 (pin A-22)
- Contact 5-2 (pin A-24)
- Contact 6-2 (pin A-26)

6.9 Optional Voice Adapter Module

Voltage Inputs

- +20 Vdc Pins A-2 and A-4
- 20 Vdc Pins C-2 and C-4
- Common Pins C/A-30 and C/A-32

RF Input from Receiver Module

- 20 kHz signal through jumper JU4 to pin C/A-26
- 5.02 MHz signal through jumper JU3 to pin C/A-26

Output to Keying Module

Voice Key (pin C/A-22)

Output to Transmitter Module

AM Voice (pin A-28)

Terminal Block TB-5

- TB5/1 External receiver signal from C/A-8
- TB5/2 External microphone input to C/A-10
- TB5/3 Common to A/C-12
- TB5/4 Alarm contact to C/A-16
- TB5/5 Alarm Contact to C/A-18
- TB5/6 External signaling input to C/A-20

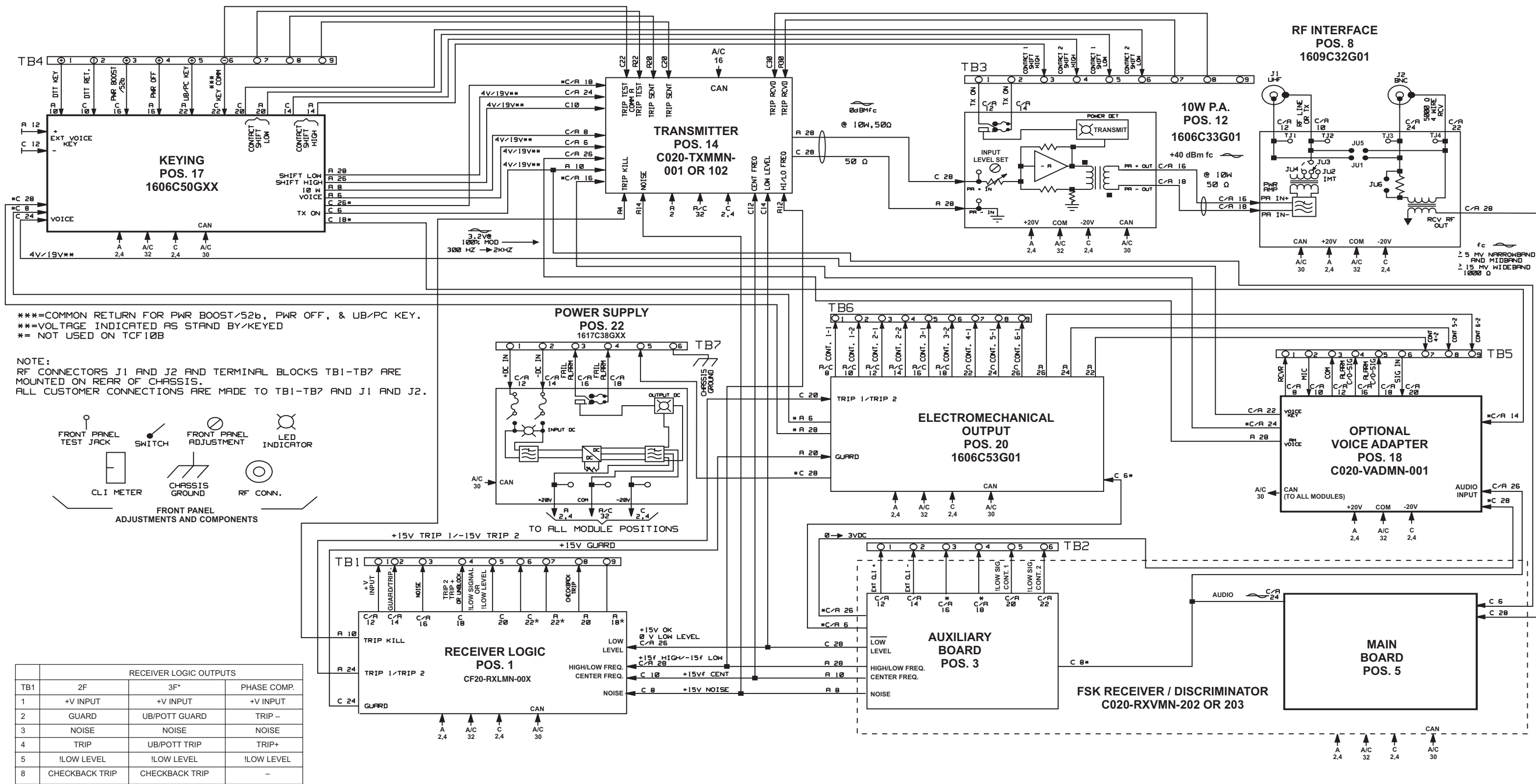

Figure 6-1. TCF-10B Functional Block Diagram. (CF44-VER06)

Chapter 7. Design Verification Tests

It is not intended to perform the design verification tests at installation. If you need to verify the design of the TCF-10B, you should perform the following design verification test. (See Test Equipment in Chapter 4, and Signal Path in Chapter 6) otherwise, see chapter 5.

If the TCF-10B is a Transmitter (only) set, perform the following segments: 7.1, 7.2, 7.3, and 7.4. If the TCF-10B is a Receiver (only) set, perform segments 7.1, 7.2, 7.5, and 7.6. If the TCF-10B is a Transceiver set, perform segments 7.1, 7.2, and 7.7.

7.1 Preliminary Checks

7.1.1 Checking the Chassis Nameplate

Verify that the proper dc supply voltage and module options are on the chassis nameplate. Also, check for narrow, wide, or extra wide band; Phase Comparison or Directional Comparison (2- or 3-Frequency).

Check to ensure that all required modules are supplied and are installed in the proper chassis slots. The slots are labeled on the top edge of the chassis.



CAUTION

ALWAYS TURN "OFF" DC POWER WHENEVER REMOVING OR INSTALLING MODULES.

7.1.2 Inspecting for the Correct dc Voltage

With the power "OFF," remove the Power Supply module and inspect it for the correct dc voltage, as specified in Table 7-1.

7.2 TCF-10B Preliminary Connections

1. Refer to the Block Diagram (see Chapter 6, Signal Path) for keying and output connections.

Table 7-1. Voltage Specifications.

Specified	Group
48V with Alarm Relay	G01
125V with Alarm Relay	G02
250V with Alarm Relay	G03

2. Connect the dc supply to the appropriate terminals on the Rear Panel (see Figures 3-1 and 3-4, in Chapter 3, Installation).

NOTE

Perform Steps 3 and 4 only if the chassis contains a transmitter.

3. Terminate the Transmitter output with a non-inductive 50Ω, 25W resistor.
4. Connect the Selective Level Meter (Rycom 6021A) across the 50Ω resistor load.

7.3 TCF-10B Preliminary Settings For Transmitter (Only) Sets

Make the following preliminary jumper and switch settings before proceeding with the tests.

7.3.1 Power Supply Module

JU1 N.C. (G01, 02, or 03)

7.3.2 Keying Module

JU1 Invert
 JU2 DCR
 JU3 1W/10W
 JU4 3 frequency
 JU6 IN*
 JU7 IN*
 JU8 N.O
 JU9 N.O
 JU10 Voltage per chassis nameplate
 JU11 Voltage per chassis nameplate
 JU12 Voltage per chassis nameplate
 JU13 Voltage per chassis nameplate
 JU14 Voltage per chassis nameplate

7.3.3 Transmitter Module

Set the four rotary switches to 250.0 kHz or the desired frequency.

7.3.4 10W PA Module

JU1 N.O

7.3.5 RF Interface Module

Matching Impedance Jumpers

JU2 (out)
 JU3 (out)
 JU4 (IN, 50 Ω)

*Place in the "OUT" position when using with the Phase Comparison relay systems.

2-Wire or 4-Wire RF Termination

JU1 (out, 4 wire)
 JU5 (out, 4 wire)

Attenuator Override Jumper

JU6 (NORM, Sensitivity)

7.4 Tests of TCF-10B Transmitter (Only) Sets



CAUTION

ALWAYS TURN DC POWER "OFF" BEFORE REMOVING OR INSTALLING CHASSIS MODULES.

7.4.1 Power Supply Module Tests

Remove all modules except power supply.

1. Turn "ON" dc power. Both LEDs (D3, Input and D11, Output) on the Power Supply Module should be "ON". Measure dc voltage at Power Supply test jacks:

- TJ1/TJ2 (+20 Vdc ± 1 Vdc)
- TJ3/TJ2 (-20 Vdc ± 1 Vdc)

If the voltage is not within the above limits, *do not* proceed further. Have the power supply repaired or replaced.

2. Turn "OFF" the dc power. The Input LED (D3) should be "OFF".
3. Place the current meter (Simpson 260 or equivalent) in series with the input dc supply and check the current for the appropriate voltage source, according to the specifications in Table 7-2:
4. Vary the input dc voltage to the minimum and maximum levels per the following chart:

<u>Nominal</u>	<u>Min</u>	<u>Max</u>
48V	38V	70V
125V	88V	140V
250V	176V	280V

Table 7-2. Voltage Specifications.

VOLTAGE	CURRENT (Amps)		
	TX Only Key @ 1W	RCV Only	TXCVR Key @ 10W
48 Vdc	0.7 – 0.9	0.3 – 0.6	0.9 – 1.1
125 Vdc	0.2 – 0.4	0.15 – 0.25	0.3 – 0.5
250 Vdc	0.1 – 0.2	0.05 – 0.15	0.15 – 0.25

Table 7-3. Transmitter Output Levels.

Keyed Level	10W PA Input	Output Across 50Ωs	RF Interface Line-Common ***	10W PA* Control	XMTR Adjust
Normal (1W)	-10.2 to -9.8 dBm (69.1 to 72.35mVrms)	29.8 to 30.2 dBm (6.57 to 7.57 Vrms)	29.8 to 30.2 dBm (6.57 to 7.57 Vrms)	—	R12
HL (10W)**	-0.2 to + 0.2 dBm (210 to 230mVrms)	39.8 to 40.2 dBm (21.00 to 23.00Vrms)	39.8 to 40.2 dBm (21.00 to 23.00Vrms)	Input Level	R13

* Set the 10W PA control first, so that the output across 50Ωs is 40 dB greater than the input to the 10W PA. Then adjust R12 (or R13) to obtain specified levels across 50Ω.

** Push HL test button on the Keying module to obtain a 10W level.

*** When strapped for 50Ω and terminated in 50Ω; values will be different for 75Ω and for 100Ω.

- Observe the front panel voltages to make sure they are as specified in Step 2 above. Both LEDs should be “ON”.
- Return to nominal dc voltage.

7.4.2 Transmitter Tests

Input/Output Levels

Use the Selective Level Meter to measure levels per Table 7-3. If the 10W PA input level is not within limits, place the Transmitter module on an extender board (see Figure 4-1), and make the adjustments with controls per Table 7-3.

Transmitter Frequencies

Monitor the output frequency of the XMTR with the Selective Level Meter. If this frequency is incorrect by $> \pm 10$ Hz, adjust the unshifted frequency with C19 (on the Transmitter module) to 250 kHz (or the required frequency) ± 1 Hz.

Use the “SH” and “SL” buttons on the Keying module to shift the output frequencies. The shift should be in accordance with Table 7-5 (within ± 10 Hz).

If the shifts are incorrect, set the shift (with S5) on the Transmitter module.

Observe the module LEDs shown in Table 7-4 below:

Table 7-4. Transmitter LEDs.

	Keying		10W PA
	H.L.	“TX”	“TRANSMIT”
1W	OFF	ON	ON
10W	ON	ON	ON

Harmonics

1. Use the Selective Level Meter to measure values of the 2nd, 3rd, and 5th harmonics at the set frequency.
2. Push the “HL” test button on the Keying module; observe fundamental and harmonic levels across the load to be:

Fundamental: +40 dBm ±0.2 (22.4Vrms)

Harmonics: Less than -15 dBm (55 dB below fundamental level)

Table 7-5. Output Frequency Shifts.

Type	SH	SL
Narrow or Wide Band, Narrow Shift	+100 Hz	-100 Hz
Wide Band, Wide Shift	+250 Hz	-250 Hz
Extra Wide Band, Extra Wide Shift	+500 Hz	-500 Hz

Table 7-6. Keying Module Links, LEDs and Output.

Inputs				Keying Module Links								Keying Module LEDs					XMTR Output Across 50Ω
PWR OFF Key	DTT Key	UB POTT PC	52b Power Boost	J U 1	J U 2	J U 3	J U 4	J U 6	J U 7	J U 8	J U 9	D5 TX	D4 V	D3 SL	D2 SH	D1 HL	
TB4/4 Pos to TB4/6 Neg	TB4/1 Pos to TB4/2 Neg	TB4/5 Pos to TB4/6 Neg	TB4/3 Pos to TB4/6 Neg	PWR ON NORM/ INV	DCR/ PCR 10 W/ 10W	1 W- 10 W/ 10 W-	2F/ 3F										
0	0	0	0	NORM	DCR	1/10	2F	IN	IN	N.O.	N.O.	0	0	0	1	0	—
0	0	1	0	NORM	DCR	1/10	2F	IN	IN	N.O.	N.O.	0	0	1	0	1	—
1	0	0	0	NORM	DCR	1/10	2F	IN	IN	N.O.	N.O.	1	0	0	0	0	1W
1	1	0	0	NORM	DCR	1/10	2F	IN	IN	N.O.	N.O.	1	0	1	0	1	10W
1	0	1	0	NORM	DCR	1/10	2F	IN	IN	N.O.	N.O.	1	0	1	0	1	10W
1	1	0	0	NORM	DCR	1/10	3F	IN	IN	N.O.	N.O.	1	0	1	0	1	10W
1	1	1	0	NORM	DCR	1/10	3F	IN	IN	N.O.	N.O.	1	0	0	1	1	10W
1	0	0	0	NORM	DCR	1/10	3F	IN	IN	N.O.	N.O.	1	0	0	0	0	1W
1	0	0	0	NORM	DCR	10/10	2F	IN	IN	N.O.	N.O.	1	0	0	1	1	10W
1	0	0	1	NORM	PCR	1/10	2F	IN	IN	N.O.	N.O.	1	0	0	1	1	10W

LEGEND:
 0 – No Voltage Applied
 1 – Battery Voltage Applied

Keying Logic

Set the Keying module links and apply keying voltage inputs, per Table 7-6. Observe the output levels and Keying module LEDs per Table 7-6.

Residual Noise Output

With the Transmitter unkeyed, observe the output between 20 kHz and 2.0 MHz. There should be *no* output indication, and the “noise floor” should be less than -20 dBm (22.4 mVrms).

7.4.3 Final Jumper Positions

Place jumpers on the Power Supply, Keying, 10 W PA, and RF Interface modules as required by the final application (see Section 3, Installation, for jumper summary). Set the four rotary switches on the Transmitter Module to the correct frequency.

7.5 TCF-10B Preliminary Settings for Receiver (Only) Sets

Make the following preliminary jumper and switch settings before proceeding with the tests.

7.5.1 Power Supply Module

JU1 N.C. (G01,02, or 03 only)

7.5.2 RF Interface Module

Matching Impedance Jumpers:

JU2 (OUT)
JU3 (OUT)
JU4 (IN, 50Ω)

Two-wire or four-wire RF Termination:

JU1 (OUT, 4 wire)
JU5 (OUT, 4 wire)

Attenuator Override Jumper:

JU6 (NORM, Sensitivity)

7.5.3 Receiver Module

DIP Switch (SW1)

Pos. 1 OPEN Pos. 5 OPEN
Pos. 2 OPEN Pos. 6 OPEN

Pos. 3 OPEN Pos. 7 OPEN

Pos. 4 OPEN Pos. 8 OPEN

Set the center frequency to 535 kHz.

7.5.4 Receiver Logic Module

Phase Comparison (2 Frequency):

SW1-1 OPEN (OFF) — 2 FREQUENCY
SW1-2 CLOSED (ON) — POSITIVE POLARITY
SW1-3 CLOSED (ON) — SKBU

Directional Comparison or Direct Transfer Trip (2-Frequency):

SW1-1 OPEN (OFF)	}	TRIP DELAY = 16 ms
SW1-2 OPEN (OFF)		
SW1-3 OPEN (OFF)		
SW1-4 CLOSED (ON)		
SW1-5 OPEN (OFF)	}	TRIP HOLD TIMER
SW1-6 OPEN (OFF)		
SW1-7 OPEN (OFF)	}	GUARD HOLD TIMER
SW1-8 OPEN (OFF)		
SW2-1 OPEN (OFF)	}	UNBLOCK TIME = DISABLED
SW2-2 OPEN (OFF)		
SW2-3 OPEN (OFF)	— NOISE ALLOWS UB TRIP	
SW2-4 CLOSED (ON)	}	GUARD BEFORE TRIP WITHOUT OVERRIDE
SW2-5 OPEN (OFF)		
SW2-6 OPEN (OFF)	}	NOT USED
SW2-7 OPEN (OFF)		
SW2-8 OPEN (OFF)		
SW3-1 OPEN (OFF)	}	NOT USED
SW3-2 OPEN (OFF)		
SW3-3 OPEN (OFF)		
SW3-4 OPEN (OFF)		
SW3-5 OPEN (OFF)	}	LOW LEVEL DELAY = DISABLED
SW3-6 OPEN (OFF)		
SW3-7 OPEN (OFF)		
SW3-8 OPEN (OFF)		

Directional Comparison and Direct Transfer Trip (3-Frequency):

SW1-1 OPEN (OFF)	}	UB/POTT TRIP DELAY = 0 ms
SW1-2 OPEN (OFF)		
SW1-3 OPEN (OFF)		
SW1-4 OPEN (OFF)		
SW1-5 OPEN (OFF)	}	TRIP HOLD = 0 ms
SW1-6 OPEN (OFF)		
SW1-7 OPEN (OFF)	}	GUARD HOLD = 0 ms
SW1-8 OPEN (OFF)		
SW2-1 CLOSED (ON)	}	UNBLOCK TIME = 500 ms
SW2-2 CLOSED (ON)		
SW2-3 OPEN (OFF)	— NOISE ALLOWS UB TRIP	
SW2-4 CLOSED (ON)	}	GUARD BEFORE TRIP WITHOUT OVERRIDE
SW2-5 OPEN (OFF)		
SW2-6 CLOSED (ON)	}	DTT TRIP DELAY = 30 ms
SW2-7 CLOSED (ON)		
SW2-8 CLOSED (ON)		
SW3-1 CLOSED (ON)	}	TRIP HOLD = 0 ms
SW3-2 OPEN (OFF)		
SW3-3 OPEN (OFF)		
SW3-4 OPEN (OFF)	}	GUARD HOLD = 0 ms
SW3-5 OPEN (OFF)		
SW3-6 CLOSED (ON)	— CHECKBACK #2	
SW3-7 OPEN (OFF)	}	LOW LEVEL DELAY = DISABLED
SW3-8 OPEN (OFF)		

7.5.5 Optional EM Output Module

	<u>2 Frequency</u>	<u>3 Frequency</u>
JU1	Guard	Guard
JU2	Guard	Guard
JU3	Guard	Trip 1
JU4	Trip 1	Trip 1
JU5	Trip 1	Trip 2
JU6	Trip 1	Trip 2
JU7	N.O.	N.O.
JU8	N.O.	N.O.
JU9	N.O.	N.O.

JU10	N.O.	N.O.
JU11	N.O.	N.O.
JU12	N.O.	N.O.
JU13*	100-200 ms	100-200 ms
JU14*	100-200 ms	100-200 ms

*Only supplied on 1606C53G02.

7.6 Tests of TCF-10B Receiver (Only) Sets

CAUTION
<p style="margin: 0; font-weight: bold; font-size: 0.9em;">ALWAYS TURN DC POWER “OFF” BEFORE REMOVING OR INSTALLING MODULES IN THE CHASSIS.</p>

7.6.1 Power Supply Module Tests

Repeat steps (1 thru 6) listed under Section 7.4.1, Power Supply Module Tests.

7.6.2 Receiver Module Tests: Preliminary Steps

Received Signal Path

1. Connect the Signal Generator to the RF Interface module Receiver (J2) on the Rear Panel and, with the power “ON”, set the Signal Generator to 535 kHz at a level of 1.0 Vrms.
2. At the RF Interface module, measure (at RCVR/RCVR COM terminals) .99 to 1.1Vrms; do not rely on the Signal Generator display.
3. Using the Selective Level Meter, measure the input signal level at the Receiver front panel (at INPUT, COMMON terminals). The signal level should be between 180 mV and 260 mV.
4. Turn the power “OFF”.

<p style="margin: 0; font-weight: bold; font-size: 0.9em;">NOTE</p> <p style="margin: 0; font-weight: bold; font-size: 0.8em;">To prevent the cable’s capacitance from affecting the measurement, do not use coaxial cable for this measurement.</p>
--

7.6.3 Frequency & Sensitivity Setting

To change settings on the FSK receivers, complete the following sequence:

1. Push the SET button.

This causes the frequency display to begin flashing, indicating that the receiver is in the “setting” mode.

If you do not touch any of the buttons for approximately three minutes, the receiver exits the setting mode and reverts to the previous settings.

2. Set the frequency.

To keep the displayed frequency, press the SET button again.

To increase the frequency, push the CANCEL/RAISE button; to decrease it, push the LOWER button. Pushing either button once and releasing it raises or lowers the frequency by the minimum increment, 0.5 kHz. Holding down either button for more than two seconds increases the incrementing speed. If you exceed the maximum of 535 kHz, the display rolls over to the lower end, 30 kHz, and continues scrolling.

After you have the desired frequency displayed, release the button. The display once again flashes, indicating that it is still in the “setting” mode and has not yet accepted the new setting. Press the SET button to accept the frequency setting.

3. Set the sensitivity.

After you set the frequency, the display scrolls this message: "Set Sens?... – Hit Set or Cancel...".

To keep the current sensitivity setting, press the CANCEL/RAISE button.

To tell the receiver to automatically set the sensitivity based on an incoming remote signal, press the SET button. This sets the receiver for a 15 dB margin and calibrates the CLI meter to 0 dB. While the receiver is setting the sensitivity, the display scrolls the message: "Working..."

At first the bar graph is blank. Then it gradually ramps up until it reaches approximately 0 dB.

The display then tells you whether the sensitivity level is okay or if there is a problem, such as a signal too weak to set for a minimum pickup level.

After the display gives the "–OK–" message, it then scrolls the message "Sens Adjust? – Hit Raise/Lower or Set when done..." Here, you can either accept the current setting or manually adjust the receiver sensitivity.

To accept the current setting, press the SET button. The receiver is now set for a 15 dB margin, and the CLI reads approximately 0 dB.

To manually adjust the receiver sensitivity up or down 10 dB, push the CANCEL/RAISE or LOWER button. The CLI will track accordingly and remain at that level to indicate the sensitivity is set that much below or above the 15 dB setting.

Sometimes the incoming signal may not be strong enough to raise the margin the full 10 dB. If this happens, the display says "Warning: signal too low for more gain - hit Set to continue.." When this happens, push the SET button. This lowers the sensitivity to an acceptable level and flashes the bar graph to remind you that you are still in the “setting” mode.

To accept the displayed level, push the SET button.

4. Set the external CLI.

Once you have completed the sensitivity setting, the display scrolls this message: "Set Ext CLI? – Hit Raise/Lower or Set when done..."

To calibrate the external CLI push the CANCEL/RAISE or LOWER button. The external CLI meter will move up and down accordingly. The external meter is a 100 μ A instrument. If it is calibrated in μ A, the meter should be set to read 67 μ A (this is equivalent to 0 dB on the internal meter). The setting should be varied 3.3 μ A for each dB the margin adjustment has been raised or lowered from the 15 dB margin. If the meter is calibrated in dB, set the meter to read equal to the internal CLI meter.

To accept the displayed level, push the SET button.

This completes the FSK setting procedure.

Table 7-7. FSK Receiver (SW1-1 settings).

SWITCH SETTING	OFF	ON
SW1-1	FSK	AM
SW1-2	NO VOICE ADAPTER	VOICE ADAPTER
SW1-3	DTT (50 ms D.O. on noise clamp)	UB (10 ms D.O. on noise clamp) UB 2F or 3 Frequency
SW1-4	DIRECTIONAL COMPARISON RELAYING	PHASE COMPARISON RELAYING
SW1-5	SHIFT DOWN TO TRIP 2F or 3F	SHIFT UP TO TRIP 2F only

Note: It is recommended that the Receiver Logic pre-trip time delay be for a minimum of 4 ms for Direct Transfer Trip Applications. Refer to Receiver Logic Section for settings.

Table 7-8. FSK Receiver (SW1-1 set to the OFF position).

SW1-6	SW1-7	SW1-8	BANDWIDTH	SHIFT	2F/3F
OFF	OFF	OFF	380 Hz	100 Hz	2F
OFF	OFF	ON	800 Hz	250 Hz	2F
OFF	ON	OFF	1600 Hz	500 Hz	2F
OFF	ON	ON	800 Hz	250 Hz	3F
ON	OFF	OFF	1600 Hz	500 Hz	3F
ON	OFF	ON	800 Hz	100 Hz	2F
ON	ON	OFF	1600 Hz	250 Hz	2F

Receiver Logic Module

Place the Receiver Logic Module on an extender board and set the input signal to 250 kHz, or the required frequency, at a level of 112 mVrms, making sure the carrier level meter reads 0 dB.

To test the Phase Comparison Units (Only), complete the five steps depicted in Table 7-9.

To test the 2-Frequency Directional Comparison Units (Only), complete the 11 steps depicted in Table 7-10.

To test the 3-Frequency Directional Comparison Units (Only), complete the six steps depicted in Table 7-11. Use an input frequency of 250 kHz or the center frequency.

† On 3-frequency units (OFF).

* Should just light at this level. This is a low signal clamp on a 10 dBm reduction of signal; you may set other levels as required.

Table 7-9. Phase Comparison Units (Only) Testing.

Good Channel	Rcvr Logic LEDs		CLI/Discrim. LEDs		Solid State Outputs				Low Signal Contact
	Trip -	Trip +	Noise	Low Level	Noise	Low Level	Trip -	Trip +	
	1) Check initial LED, output, and contact states:								
OFF	OFF	OFF	ON	OFF	+ V*	+ V*	0V	0V	OPEN
	2) Remove input signal from chassis; observe states as follows:								
OFF	ON	ON	ON	ON	+ V*	0V	+ V*	+ V*	CLOSED
	3) Open SW1-3 on Receiver Logic Module; observe states as follows:								
OFF	OFF	OFF	ON	ON	+ V*	0V	0V	0V	CLOSED
	4) Close SW1-3 (SKBU) and re-connect input signal to chassis. Set input frequency to 250.500 kHz (EWB), or 250.250 kHz (WBWS); or required frequency + 500 Hz (EWB), or required frequency + 250 Hz (WBWS). Observe states as follows:								
ON	ON	OFF	OFF	OFF	0V	+ V*	+ V*	0V	OPEN
	5) Set input frequency to 249.500 kHz (EWB), or 249.750 kHz (WBWS); or required frequency - 500 Hz (EWB), or required frequency -250 Hz (WBWS). Observe states as follows:								
ON	OFF	ON	OFF	OFF	0V	+ V*	0V	+ V*	OPEN

* + V (Nominal) outputs equals the voltage applied to the TB1-1, usually station battery.

Table 7-10. 2-Frequency Directional Comparison or Direct Transfer Trip Units (Only) Testing.

Rcvr Logic LEDs.			CLI/Disc LEDs		Optional EM Outputs						Solid State Outputs					Low Sig Cont	
Good Channel	Grd	Trp	Cbk Trp	Noise	LLev	1	2	3	4	5	6	Noise	LLEV	Cbk Trp	Grd		Trp 2
1) Check initial LED, output, and contact states:																	
OFF	OFF	OFF	OFF	ON	ON	(open)				+ V*	0V	0V	0V	0V	OP
2) Set input frequency to 250.500 kHz (EWB), or 250.250 kHz (WBWS), or 250.100 kHz (NB or WBNS); or required frequency + 500 Hz (EWB), or required frequency + 250 Hz (WBWS), or required frequency + 100 Hz (NB or WBNS). Observe states as follows:																	
ON	ON	OFF	OFF	OFF	OFF	CL	CL	CL	OP	OP	OP	0 V	+ V*	0V	+ V*	0V	OP
3) Set input frequency to 250.000 kHz. Then set input frequency to 249.500 kHz (EWB), or 249.750 kHz (WBWS), or 249.900 kHz (NB or WBNS); or required frequency -500 Hz (EWB), or required frequency -250 Hz (WBWS) or required frequency -100 Hz (NB or WBNS). Observe states as follows:																	
ON	OFF	OFF	ON	OFF	OFF	(open)				0 V	+ V*	+ V*	0V	0V	OP
4) Set input frequency to 250.500 kHz (EWB), or 250.250 kHz (WBWS), or 250.100 kHz (NB or WBNS); or required frequency +500 Hz (EWB), or required frequency +250 Hz (WBWS), or required frequency +100 Hz (NB or WBNS). Then quickly shift input frequency to 249.500 kHz (EWB), or 249.750 kHz (WBWS), or 249.900 (NB or WBNS); or required frequency -500 Hz (EWB), or required frequency -250 Hz (WBWS), or required frequency -100 Hz (NB or WBNS). Observe states as follows:																	
ON	OFF	ON	ON	OFF	OFF	OP	OP	OP	CL	CL	CL	0V	+ V*	+ V*	0V	+ V*	OP

* + V (Nominal) outputs equals the voltage applied to the TB1-1, usually station battery.

Table 7-10. 2-Frequency Directional Comparison or Direct Transfer Trip Units (Only) Testing (Cont'd).

Rcvr Logic LEDs.			CLI/Disc LEDs		Optional EM Outputs						Solid State Outputs				Low Sig Cont		
Good Channel	Grd	Trp	Cbk Trp	Noise	LLev	1	2	3	4	5	6	Noise	LLEV	Cbk Trp		Grd	Trp 2
<p>5) Set input frequency to 250.500 kHz (EWB), or 250.250 kHz (WBWS), or 250.100 kHz (NB or WBNS); or required frequency + 500 Hz (EWB), or required frequency + 250 Hz (WBWS), or required frequency + 100 Hz (NB or WBNS). Remove signal from chassis. Observe the "TRIP" LED on the Receiver Logic module, and the "TRIP 2" SS Output. Neither should blink when signal is removed. Observe states as follows:</p>																	
OFF	OFF	OFF	OFF	ON	ON	(open)		+ V*	0V	0V	0V	0V	0V	0V	CL
<p>6) Close SW2-4 and open SW2-5 (GBT without override). Reconnect the signal to the chassis. Observe states as follows:</p>																	
ON	ON	OFF	OFF	OFF	OFF	CL	CL	CL	OP	OP	OP	0V	+ V*	0V	+ V*	0V	OP
<p>7) Set input frequency as shown in Step 3 (above). Observe states as follows:</p>																	
ON	OFF	OFF	ON	OFF	OFF	(open)		0V	+ V*	+ V*	0V	0V	0V	0V	OP
<p>8) Set input frequency as shown in Step 4 (above). Observe states as follows:</p>																	
ON	OFF	ON	ON	OFF	OFF	OP	OP	OP	CL	CL	CL	0V	+ V*	+ V*	0V	+ V*	OP
<p>9) Set input frequency as shown in Step 3 (above). Observe states as follows:</p>																	
ON	OFF	ON	ON	OFF	OFF	OP	OP	OP	CL	CL	CL	0V	+ V*	+ V*	0V	+ V*	OP
<p>10) Close SW2-1 and SW2-2 (500 ms). Set input frequency to 250.500 kHz (EWB), or 250.250 kHz (WBWS), or 250.100 kHz (NB or WBNS); or required frequency +500 Hz (EWB), or required frequency +250 Hz (WBWS), or required frequency +100 Hz (NB or WBNS). Observe states as follows:</p>																	
ON	ON	OFF	OFF	OFF	OFF	CL	CL	CL	OP	OP	OP	0V	+ V*	0 V	+ V*	0V	OP
<p>11) Remove signal from chassis. Observe the "TRIP" LED and the "TRIP 2" SS Output. Both must blink when signal is removed.</p>																	
OFF																	

* + V (Nominal) outputs equals the voltage applied to the TB1-1, usually station battery.

Table 7-11. 3-Frequency Directional Comparison and Direct Transfer Trip Units (Only) Testing.

Good Channel	Rcvr Logic LEDs.				CLI/Disc LEDs		Optional EM Outputs						Solid State Outputs					Low Sig Cont
	Cbk Trp	UB/POTT Trip	DTT Trip	Grd	Noise	LLev	1	2	3	4	5	6	Noise	LLEV	Cbk Trp	Grd	Trp 2	
ON	OFF	OFF	OFF	ON	OFF	OFF	CL	CL	OP	OP	OP	OP	0V	+ V*	0V	+ V*	0V	OP
<p>1) Check initial LED, output, and contact states:</p>																		
<p>2) Remove the input signal from the chassis, and observe the following momentary occurrences:</p> <p>a) UB/POTT LED must blink.</p> <p>b) DTT LED must not blink.</p> <p>Observe the following states:</p>																		
OFF	OFF	OFF	OFF	OFF	ON	ON	OP	OP	OP	OP	OP	OP	+ V*	0V	0V	0V	0V	CL
<p>3) Re-connect signal input to chassis. Set input frequency to 250.500 kHz (EWB), or 250.250 kHz (WBWS), or regular frequency +500 Hz (EWB), or required frequency +250 Hz (WBWS). Observe the following states:</p>																		
ON	ON	ON	OFF	OFF	OFF	OFF	CL	CL	OP	OP	CL	CL	0V	+ V*	+ V*	0V	+ V*	CL
<p>4) Set input frequency to 249.500 kHz (EWB), or 249.750 kHz (EWB), or 249.750 kHz (WBWS), or required frequency -500 Hz (EWB); or required frequency -250 Hz (WBWS). Observe the following states:</p>																		
ON	OFF	OFF	ON	OFF	OFF	OFF	OP	OP	CL	CL	OP	OP	0V	+ V*	0V	+ V*	0V	OP

* + V (Nominal) outputs equals the voltage applied to the TB1-1, usually station battery.

Table 7-11. 3-Frequency Directional Comparison and Direct Transfer Trip Units (Only) Testing (Cont'd).

Rcvr Logic LEDs.					CLI/Disc LEDs		Optional EM Outputs						Solid State Outputs				Low Sig Cont	
Good Channel	Cbk Trp	UB/POTT Trip	DTT Trip	Grd	Noise	LLev	1	2	3	4	5	6	Noise	LLEV	Cbk Trp	Grd		Trp 2
<p>5) Set input frequency to 250.0 kHz. Then slowly decrease the input frequency to 249.500 kHz (EWB), or 249.750 kHz (WBWS); or required frequency -500 Hz (EWB), or required frequency -250 Hz (WBWS), or required frequency -100 Hz (NB or WBNS). Observe the CLI module "NOISE" LED and "NOISE" SS Output to go "ON" then "OFF" as the frequency is decreased. When final frequency is reached, observe the following states:</p>																		
ON	OFF	OFF	OFF	OFF	OFF	OFF	CL	CL	OP	OP	OP	OP	0V	+ V*	0V	+ V*	0V	OP
<p>6) Slowly increase the input frequency to 250.500 kHz (EWB), or 250.250 kHz (WBWS); or required frequency +500 Hz (EWB), or required frequency +250 Hz (WBWS). Observe the CLI module "NOISE" LED and "NOISE" SS output to go "ON" then "OFF" twice as the frequency is increased. When the final frequency is reached, observe the following states:</p>																		
ON	ON	OFF	OFF	OFF	OFF	OFF	CL	CL	OP	OP	OP	OP	0V	+ V*	+ V*	0V	0V	OP

* + V (Nominal) outputs equals the voltage applied to the TB1-1, usually station battery.

7.6.3 Place Jumpers as Required

To test the Phase Comparison Units (Only), complete the five steps depicted in Table 7-9.

Place jumpers and switches as required by the final application (see 7.3 or 7.5).

7.7 TCF-10B Transceiver Tests

7.7.1 Voice Adapter in System

Check the preliminary settings (earlier in this Section): 7.3.1 thru 7.3.5 and 7.5.1 thru 7.5.5. If the

	CAUTION
ALWAYS TURN DC POWER "OFF" BEFORE REMOVING OR INSTALLING MODULES IN THE TCF-10B CHASSIS.	

Voice Adapter Module is part of system, set the following:

JMP1	N.O. or N.C.
SW1	
1	ON
2	OFF
3	OFF
4	ON

7.7.2 Power Supply Module Tests

Perform steps 1 through 6 of Section 7.4.1, Power Supply Module Tests, *except use the current values in Section 7.4.1 Step 5.*

7.7.3 Transmitter Module Tests

Perform the steps in Section 7.4.2, Transmitter Tests, *except set the transmitter frequency at 254 kHz.*

7.7.4 Receiver Module Tests

Perform the steps in Section 7.6.2, Receiver Tests.

7.7.5 Voice Adapter Module Tests (If Supplied)

1. Plug in the handset to the front panel (TJ1); connect it to the rear panel (TB5) if it is a remote handset. Key the carrier set with the calling pushbutton. The Transmitter should be keyed at voice-level (4.3 W when high-level is 10 W).
2. You may turn the "RECEIVE AUDIO" (P1) adjustment as required to obtain a desirable listening level.

Chapter 8. Maintenance

When individual module maintenance is required, either at the factory or at the customer installation (beyond the scope of routine alignment), the following procedures are applicable.

8.1 Precautions When Selecting Test Equipment

(See Chapter 4, Test Equipment for test equipment specifications.)

To prevent damage to solid-state components:

- 1) Use transformer-type signal generators, VTVMs and signal tracers, which isolate the test equipment from the power line. Whenever the test equipment uses a transformerless power supply, use an isolation type transformer. The test equipment ground should be isolated from the ac source ground.
- 2) Use multi-meters with at least 20,000 Ω s-per-volt sensitivity.

8.2 Precautions When Using Test Equipment

1. Use a common ground between the chassis of the test equipment and the transistor equipment.



CAUTION

HIGH CURRENTS FROM A LOW-SENSITIVITY METER CAN DAMAGE SOLID STATE DEVICES.

METERING TRANSISTOR CIRCUITS CAN CAUSE DAMAGE.

FOR EXAMPLE: A BASE-TO-COLLECTOR SHORT DURING TRANSISTOR OPERATION CAN DESTROY THE TRANSISTOR.

2. When testing transistors and diodes, give special attention to the polarity of the meter leads.

For example: When measuring the forward resistance of a diode using a meter that has the internal battery connected to the metering circuit, be sure that:

- The lead marked (-) touches the diode anode.
 - The lead marked (+) touches the diode cathode.
3. When checking circuits with an oscillographic probe, be sure to discharge any built-up capacitive voltage by touching the probe to a ground before touching the circuit.

8.3 Periodic Checks

Every six months, take the following readings on the TCF-10B Test Jacks (at the control panel).

We recommend that you keep a *log book* as a visible record of periodic checks, as well as a source for indicating any gradual degradation in a module's performance.

8.3.1 Power Supply Module

- TJ1 (+20 Vdc)
- TJ2 (Common)
- TJ3 (-20 Vdc)

8.3.2 Keying Module

None.

8.3.3 Transmitter Module

None.

8.3.4 10W PA Module

- TJ1 (Input)
- TJ2 (Common)

8.3.5 RF Interface Module

- TJ1 (Line In)
- TJ2 (Line Common)
- TJ3 (Receiver In)
- TJ4 (Receiver Common)

8.3.6 Receiver/Discriminator Module

None

8.3.7 Receiver Logic Module

None.

8.3.8 EM Output Module

None.

8.3.9 Optional Voice Adapter Module

None.

8.4 Inspection

A program of routine visual inspection should include:

- Condition of cabinet or other housing
- Tightness of mounting hardware and fuses
- Proper seating of plug-in relays and sub-assemblies
- Condition of internal and external wiring (the location where external wiring enters the cabinet should be sealed)
- Appearance of printed circuit boards and components
- Signs of overheating in equipment:

- Interference with proper heat dissipation from surfaces
- Clogged air vents (air filters should be removed and washed out)
- Dust which may cause short circuits

8.5 Solid-State Maintenance Techniques

Use the following techniques when servicing solid state equipment.

8.5.1 Preliminary Precautions

1. To avoid damage to circuits and components from a current surge, disconnect power before replacing or removing components or circuits.
2. Before placing new components into a defective circuit, check the circuit so that it cannot damage the new components.



CAUTION

WE RECOMMEND THAT THE USER OF THIS EQUIPMENT BECOME ACQUAINTED WITH THE INFORMATION IN THESE INSTRUCTIONS BEFORE ENERGIZING THE TCF-10B AND ASSOCIATED ASSEMBLIES.

FAILURE TO OBSERVE THIS PRECAUTION MAY RESULT IN DAMAGE TO THE EQUIPMENT. YOU SHOULD NEITHER REMOVE NOR INSERT PRINTED CIRCUIT MODULES WHILE THE TCF-10B IS ENERGIZED. FAILURE TO OBSERVE THIS PRECAUTION CAN RESULT IN COMPONENT DAMAGE.

ALL INTEGRATED CIRCUITS USED ON THE MODULES ARE SENSITIVE TO AND CAN BE DAMAGED BY THE DISCHARGE OF STATIC ELECTRICITY. BE SURE TO OBSERVE ELECTROSTATIC DISCHARGE PRECAUTIONS WHEN HANDLING MODULES OR INDIVIDUAL COMPONENTS.

8.5.2 Trouble-Detection Sequence

1. Evaluate test jack readings and other records of routine alignment.
2. Evaluate any symptoms detected audibly or visually.
3. Replace suspected plug-in components.
4. Further isolation of faults includes:
 - Voltage readings
 - Resistance readings
 - Signal injection
 - Re-alignment
 - Sensitivity measurements
 - Gain measurements
5. Replace suspected faulty components.
6. Check-out and adjust affected circuits.

8.5.3 Servicing Components Soldered Directly to Terminals

1. Avoid overheating from soldering by using a low-wattage soldering iron (60W maximum).
2. Make sure there is no current leakage from the soldering iron.

You may use an isolation transformer to prevent current leakage.
3. When soldering leads from transistors or diodes, use heat sinks, e.g., alligator clips.
4. You can remove molten solder from the board with a solder-sucker.
5. When removing a multi-lead component from a printed circuit board, first cut all leads and then remove the leads individually (to prevent overheating). If there are only a few leads, you can use a broad-tip soldering iron.

8.5.4 Servicing Components Mounted Directly on Heat Sinks

1. Remove the heat sink and bracket from the chassis by loosening the securing devices.
2. Remove the transistor, diode, or other device from the heat sink.
3. When replacing the transistor, diode, or other device, make certain that the device and the heat sink make secure contact for good heat dissipation. Mount a device first on the heat sink, and then on the board. Also, make sure that you replace all insulators, washers, spring washers and other mounting hardware as you originally found them.

We recommend a very light coating of DC-4 (Dow-Corning 4 Compound Silicon Lubricant) for transistors and diodes that are mounted on heat sinks.

8.5.5 Servicing Metal Oxide Semiconductor (MOS) Devices

MOS devices may be vulnerable to static changes. Be sure to observe the special precautions described below both before and during assembly.

Precautions to take before assembly:

- Avoid wearing silk or nylon clothing, as this contributes to static buildup.
- Avoid carpeted areas and dry environments.
- Discharge body static by placing both hands on a metal, earth-grounded surface.

Precautions to take during assembly to avoid the possibility of electrostatic discharge:

- Wear a ground strap during assembly
- Avoid touching electrically-conductive circuit parts by hand
- When removing a module from the chassis, always place it on a conductive surface which is grounded through a resistance of approximately 100 K Ω
- Make sure that all electrically-powered test equipment is properly grounded.

NOTE

Before touching a module with a test probe, connect the ground lead from the test equipment to the module. Always disconnect the test probe before removing the ground lead equipment.

Chapter 9. Power Supply Module

Table 9–1. 1617C38 Styles and Descriptions.

Group	Description
G01	48V WITH ALARM RELAY
G02	125V WITH ALARM RELAY
G03	250V WITH ALARM RELAY

Schematic 1617C38-6

9.1 Power Supply Module Description

The Power Supply Module for the TCF–10B has dual dc/dc high-frequency switching regulators which generate regulated voltage outputs of ± 20 Vdc (between 1.5A and 2.0A) for operation of the TCF–10B modules. It also provides protection from battery surge, transients, short circuits, and reverse voltage. The Power Supply Module can receive inputs from three available groups of station batteries: 38-70 Vdc, 88-140 Vdc, and 176-280 Vdc.

9.1.1 Power Supply Control Panel

(This panel is shown in Figure 9-1.)

Front panel controls are as follows:

- 1) Push-button Switch (with power-on indicator), ON/OFF (S1).
- 2) LEDs for indicating power:
 - INPUT, Red (LED1)
 - OUTPUT, Red (LED2)
- 3) Test Jacks:
 - +20 Vdc, Red (TP3)
 - Common, Green (TP2)
 - -20 Vdc, Black (TP1)

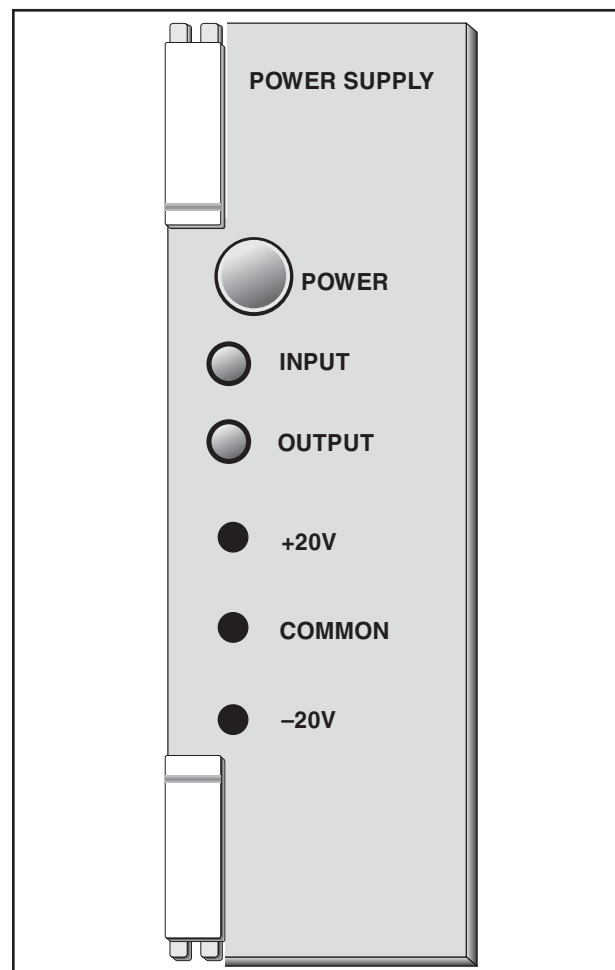

Figure 9–1. Power Supply Module – Front Panel.

A low-voltage alarm relay, which indicates loss of power, is available. The relay is energized when input power is present and the power supply is functional.

9.1.2 Power Supply PC Board

Figure 9-2 shows component locations for the Power Supply Module.

Control is as follows:

Jumper J1 for Alarm Relay; establishes loss of power condition (NO/NC).

NOTE

JU1 is shipped in the NC state.

9.2 Power Supply Circuit Description

The module comprises the following circuits:

- Fuses
- ON/OFF Switch
- Input Filter
- Power Alarm Failure Relay
- dc/dc Converter (2)
- Output Filter

Fuses

	<u>48 V</u>	<u>125 V</u>	<u>250 V</u>
F1, F2	3A	1.6A	3/4A

ON/OFF Switch

S1 - Push-button Switch (DPDT)

When in the “ON” position (pins 1 and 4), dc current flows through the input filter to the dc/dc converter.

Input Filter

The input filter (C1, C2, C3) contains zener diodes (Z1, Z2) that provide protection against surges, a diode (D1) that provides protection against reverse polarity, a differential choke XFMR (L1), and the Red Input LED1.

Power Alarm Failure Relay

This circuit includes:

- K1 - Alarm Relay
- J1 - Jumper (NO/NC)

The field-selectable option can change the alarm contact de-energized state to NO or NC. (It is currently shipped in the NC de-energized state, and can be changed to NO if desired.)

DC/DC Converter

The two dc/dc converters (PS1 and PS2) operate at a maximum of 1 MHz and, as a result, switching noise is outside the 30-535 kHz range of the TCF-10B. The converter outputs, +20 Vdc and -20 Vdc, is fed to the output filter. (See Figure 9-3.)

Output Filter

The output filter for the +20V consists of C4, C6, C8, and Z4. The output filter for the -20V consists of C5, C7, C9, and Z3.



CAUTION

BE CAREFUL NOT TO MISPLACE SCREWS, SPRING WASHER OR INSULATING WASHER USED FOR MOUNTING TRANSISTORS.

9.3 Power Supply Troubleshooting

The three test jacks on the control panel:

- TP3 (+20 Vdc)
- TP2 (Common)
- TP1 (-20 Vdc)

can be used to determine if the two voltages (+20 Vdc, -20 Vdc) are present. In addition, the LED2 output indicates that the dc/dc converters are generating voltage. The LED1 input indicates that voltage is present at the input of the dc/dc converter.

For basic troubleshooting, perform the following procedure:

1. If LED1 is not on with the module energized, remove and check the fuses (F1, F2) with an ohmmeter.
2. With the module de-energized, check the ON/OFF switch (S1) with an ohmmeter to be sure it opens and closes accordingly..
3. If LED2 is not on with the module energized, check the +20V and -20V outputs at TP3 and TP1, respectively. The one with voltage absent will require replacement of the associated dc/dc converter.

Figure 9-2. TC-10B/TCF-10B Power Supply Component Location (1617C38 rev. 6).

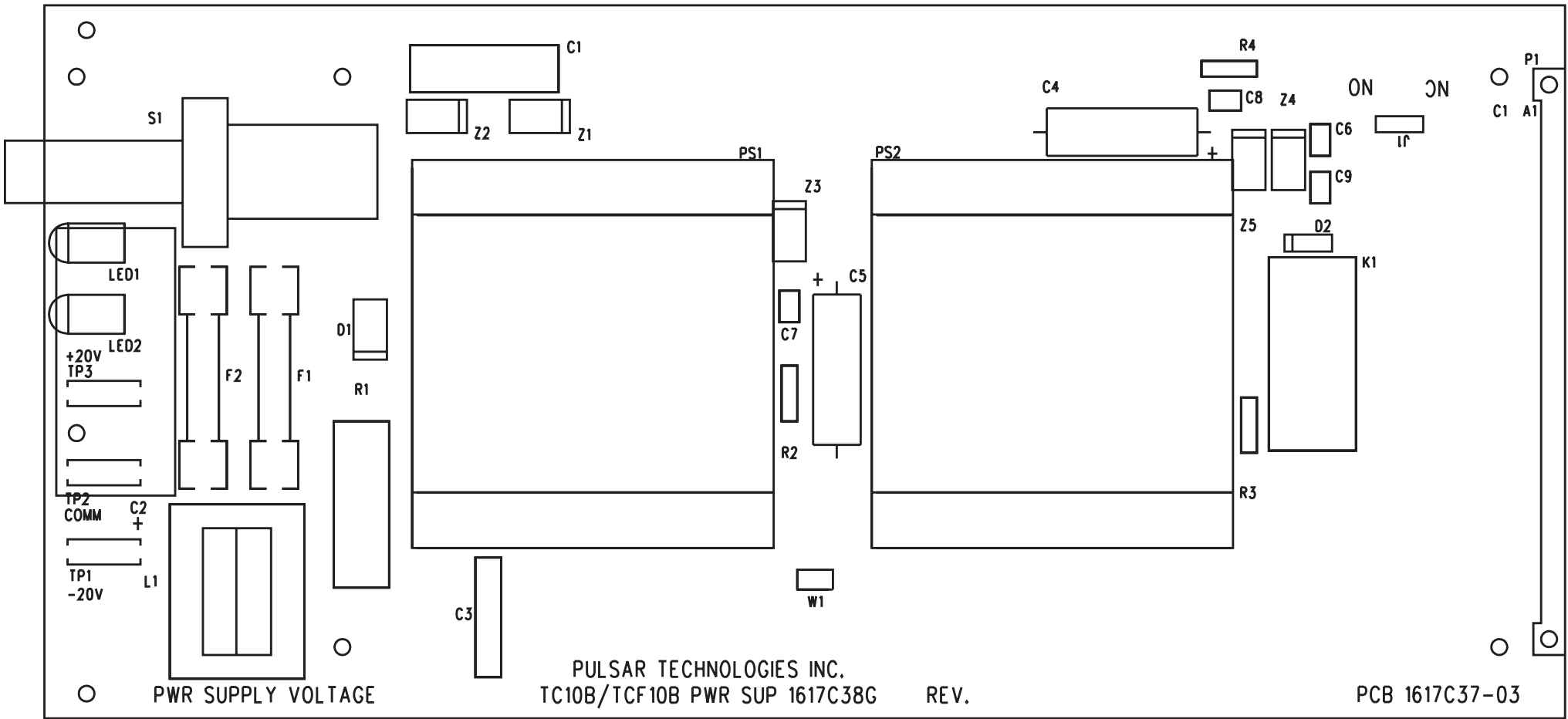

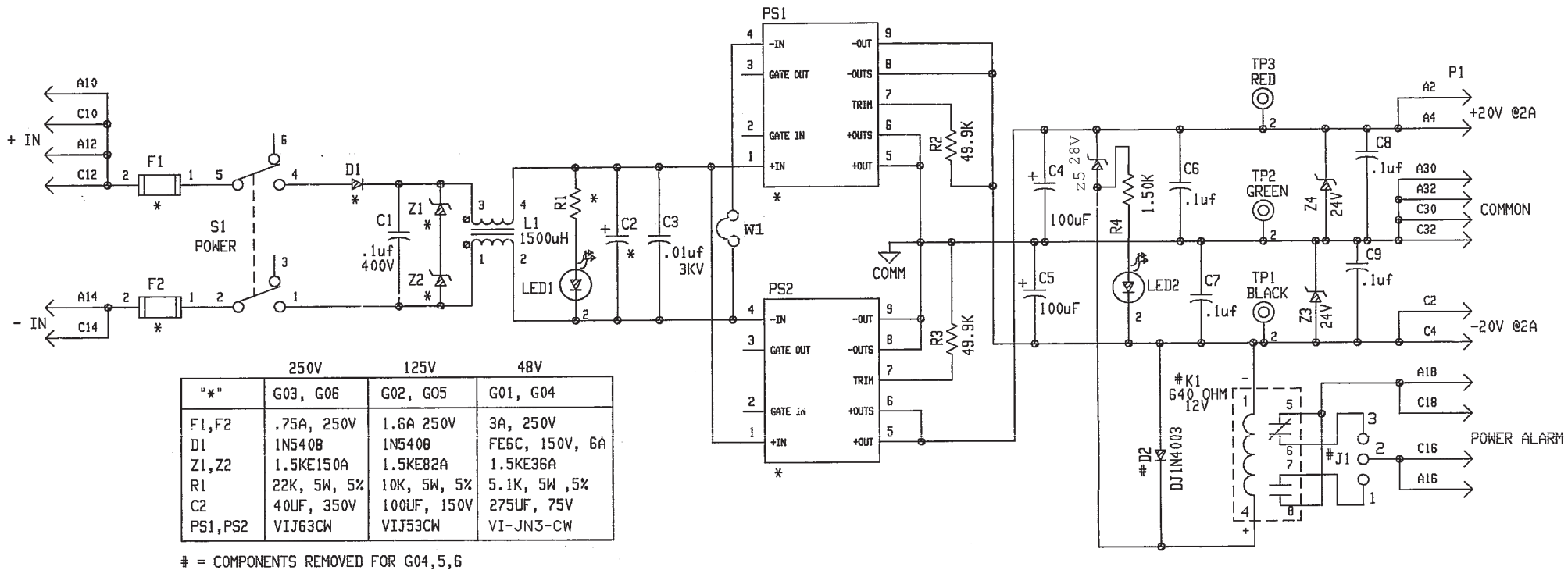

Figure 9-3. TC-10B/TCF-10B Power Supply Schematic (1617C39 rev. 6).

Chapter 10. Keying Module

Table 10–1. 1606C50 Styles and Descriptions.

Schematic	1606C50-9
-----------	-----------

Group	Description
G01	2- or 3-Frequency w/relay contacts
G03	2 - Frequency w/relay, shift up to trip

10.1 Keying Module Description

The TCF–10B Keying Module controls the Transmitter Module as follows:

- Direct Transfer Trip (DTT) Key
- 52b Keying or Power Boost (depending on application)
- Power OFF
- Unblock (UB) or Phase Comparison (PC) Key (depending on application)
- Voice Key (External or Internal)

Keying Module outputs are as follows:

- High-Level (10W), pin A-8
- Any Transmitter Key, pin C-6
- Voice, pin A-6
- Shift High, pin A-26
- Shift Low, pin A-28

10.1.1 Keying Control Panel

(This panel is shown in Figure 10-1.)

Push-Button Switches (recessed):

- High-Level (HL) Power (S1)
- Shift High (S2)
- Shift Low (S3)

LEDs for indicating Keying condition:

- High-Level (10W) (D1)

- Shift High (D2)
- Shift Low (D3)
- Voice (D4)
- Any Transmitter Key (D5)

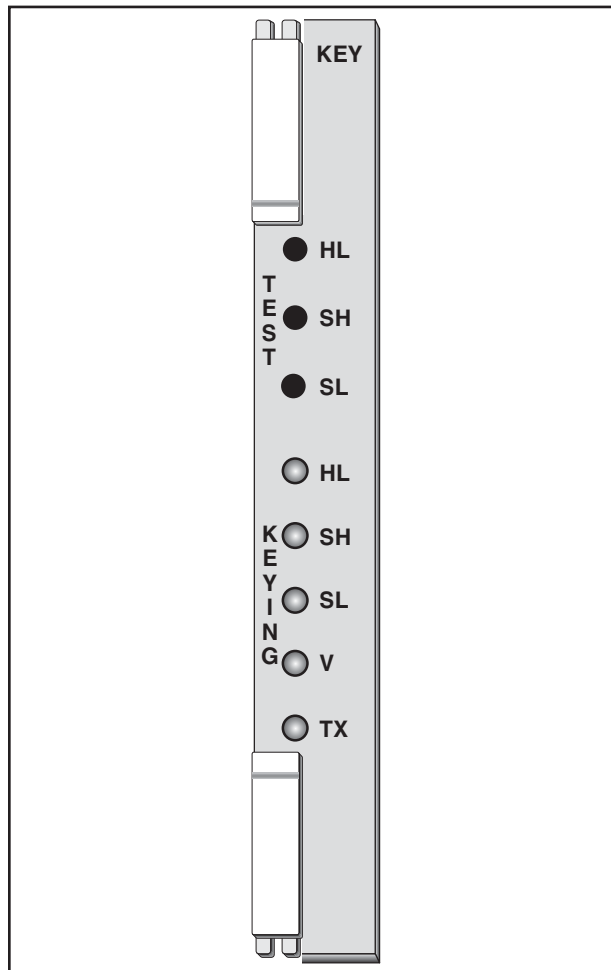

Figure 10–1. Keying Module – Front Panel.

10.1.2 Keying PC Board Jumper Controls

(The Keying PC Board Jumper Controls are shown in Figure 10-2.)

JU1	Power “OFF” (NORM/INVERT)
JU2	Directional Comparison/Phase Comparison
JU3	1W (Guard), 10W (Trip)/10W (Guard), 10W (Trip)
JU4	2-Frequency System/3-Frequency (Optional) System
JU6	Activates Shift High Contacts (IN/OUT)
JU7	Activates Shift Low Contacts (IN/OUT)
JU8	Selects NO or NC contacts for Shift High
JU9	Selects NO or NC contacts for Shift Low
JU10–	
JU14	(Input Keying voltage selections: 15V, 48V, 125V, 250V)

10.2 Keying Circuit Description

The Keying Module (see Figure 10-4, Schematic 1606C50S) provides an optically-isolated interface between the carrier and the relay system and controls the operation of the Transmitter Module.

10.2.1 Customer Inputs

Customer inputs operate as described below (see Figure 10-3):

DTT Key

With jumper JU10 set, input will be initiated when the appropriate voltage level (15V, 48V, 125V or 250V) is applied to pins A-10/C-10.

52b Keying or Power Boost

With jumper JU12 set, input will be power boost initiated when the appropriate voltage level (15V, 48V, 125V or 250V) is applied to pins C-16/C-22.

Power Off

With jumper JU13 set, when jumper JU1 is in NORM position, the transmitter will be keyed “ON” when proper voltage level (15V, 48V, 125V or 250V) is applied to pins A-16/C-22. When JU1 is in the INVERT position, the transmitter will be keyed “ON” when voltage is removed from input A-16/C-22.

UB or PC Key

With jumper JU14 set, input will be initiated when the appropriate voltage level (15V, 48V, 125V or 250V) is applied to pins A-22/C-22.

External Voice Key

With jumper JU11 set, input will be initiated when the appropriate voltage level (15V, 48V, 125V or 250V) is applied to pins A-12/C-12.

Internal Voice

This input (C-24) will be initiated when the optional voice adapter is installed, and the push-to-talk button switch is pushed.

10.2.2 Jumper Selections

The following jumper selections are available:

- JU1 Allows selection between NORM/INVERT. Selecting the normal (NORM) position will turn “ON” the Transmitter when proper voltage level (15V, 48V, 125V, 250V) is applied to pins A-16/C-22. Selecting the invert (INV) position will turn “ON” the Transmitter when voltage is removed from input pins A-16/C-22.
- JU2 Selects between a directional comparison system and a phase comparison system.

- JU3 This link allows selection between 1W (Guard)/10W (Trip) or 10W (Guard)/10W(Trip) operation by placing link in 1/10W or 10/10W position, respectively.
- JU4 Selecting the 2-frequency (2F) position will set the Keying Module in mode to correctly operate as a 2-frequency system. Selecting the 3-frequency position will set the Keying Module in mode to correctly operate as a 3-frequency system.
- JU6 Placing JU6 to IN position activates the shift high contact; the OUT position deactivates the shift high contact.*
- JU7 Placing JU7 to IN position activates shift low contact; OUT position deactivates shift low contact.*
- JU8 Places shift high contacts in either normally open (NO) position or normally closed (NC) position.
- JU9 Places shift low contacts in either normally open (NO) position or normally closed (NC) position.
- JU10–
- JU14 Provides input keying voltage selections: 15V, 48V, 125V, 250V.

10.2.3 Testing

You can also initiate a high-level test by pressing the (recessed) push-button switch (S1) on the front panel. You can also initiate a shift high test by pressing the (recessed) push-button switch (S2) on the front panel. You can also initiate a shift low test by pressing the (recessed) push-button switch (S3) on the front panel.

*Place in the “OUT” position when using with the Phase Comparison relay systems.

10.2.4 Voltage Regulation

Zener diodes D10, D12, D14, D16, and D18 limit the input voltage to the optical isolators (I5, I6, I7, I8, and I9, respectively) and also provide reverse voltage protection. Zener diodes D6 and D7 regulate primary power (pins A-2/4, A-30/32, C-30/32) down to 15V, and also provide reverse voltage protection.

10.3 Keying Troubleshooting

Should a fault occur in the Keying Module, place the module on an extender board.

You may test the five optical isolators (I5 through I9) using the on-board +18.6 Vdc source (D6 cathode). When a logic “1” is applied to any of the 15V inputs (R43, R46, R40, R34, R37), with the jumper removed, pin 5 of the selected optical isolator (I5, I6, I7, I8 or I9) will go high.

 CAUTION
<p style="margin: 0;">DO NOT ATTEMPT TO FORCE A LOGIC “1” (+18.6VDC) ON ANY OUTPUTS OR INPUTS CONNECTED TO OUTPUTS. THIS COULD DAMAGE AN IC. SEE FIGURE 10-3 FOR INTERNAL LOGIC.</p>

You can check other components on the PC Board by conventional means.

When the appropriate jumper is in place on the board, jumpers JU10, JU11, JU12, JU13, and JU14 provide logic “1” or “0” inputs. Logic “1” is +18.6 Vdc; logic “0” is +8.6 Vdc. See Table 10-2, Truth Tables for TCF–10B Keying Modules, which describes the operation of the logic blocks used. Proper voltage levels of these input commands must be observed.

Table 10-2. Truth Tables for TCF-10B Keying Modules. (G01 - shift down to trip)

PWR OFF	UNBLK KEY	52B PWR	DTT KEY	EXT VOICE	INT VOICE	JU1 LINK	JU2 LINK	JU3 LINK	JU4 LINK	*JU6 LINK	*JU7 LINK	*JU8 LINK	*JU9 LINK	CONT *HI	CONT *LO	D5 TX KEY	D4 VOICE KEY	D3 SHFT LO	D2 SHFT HI	D1 HL KEY
0	0	0	0	0	0	NORM	DCR	1/10	2F	IN	IN	NO	NO	1	0	0	0	0	1	0
0	1	0	0	0	0	NORM	DCR	1/10	2F	IN	IN	NO	NO	0	1	0	0	1	0	1
0	0	0	0	0	1	NORM	PCR	10	2F	OUT	IN	NO	NO	0	0	0	1	0	1	0
0	0	0	1	0	0	NORM	PCR	10	2F	IN	OUT	NO	NO	0	0	0	0	1	0	1
0	0	0	1	0	0	NORM	PCR	1/10	3F	IN	IN	NC	NC	1	0	0	0	1	0	1
0	1	0	0	0	0	NORM	PCR	1/10	3F	IN	IN	NC	NC	0	1	0	0	0	1	0
1	0	0	1	1	0	NORM	PCR	1/10	2F	IN	IN	NO	NO	0	1	1	1	1	0	0
0	0	1	0	1	0	INV	PCR	1/10	2F	IN	IN	NO	N0	1	0	1	0	0	1	1
1	0	1	0	0	0	INV	PCR	1/10	2F	IN	IN	NO	N0	1	0	0	0	0	1	1

PWR OFF	UNBLK KEY	52B PWR	DTT KEY	EXT VOICE	INT VOICE	JU1 LINK	JU2 LINK	JU3 LINK	JU4 LINK	S1 FRONT HL	S2 PANEL SH	S3 SWITCH SL	CONT *HI	CONT *LO	D5 TX KEY	D4 VOICE KEY	D3 SHFT LO	D2 SHFT HI	D1 HL KEY
0	0	0	0	0	0	NORM	PCR	1/10	2F	0	0	0	1	0	0	0	0	1	0
0	0	0	0	0	0	NORM	PCR	1/10	2F	0	0	1	0	1	0	0	1	0	0
0	1	0	1	0	0	NORM	PCR	1/10	2F	0	1	0	0	1	0	0	1	0	0
0	0	0	0	0	0	NORM	PCR	1/10	2F	1	0	0	1	0	0	0	0	1	1

█ Link Change

* Used for G01, G03 Only

PWR OFF	UNBLK KEY	52B PWR	DTT KEY	EXT VOICE	INT VOICE	JU1 LINK	JU2 LINK	JU3 LINK	JU4 LINK	*JU6 LINK	*JU7 LINK	*JU8 LINK	*JU9 LINK	CONT *HI	CONT *LO	D5 TX KEY	D4 VOICE KEY	D3 SHFT LO	D2 SHFT HI	D1 HL KEY
0	0	0	0	0	0	NORM	DCR	1/10	2F	IN	IN	NO	NO	0	1	0	0	1	0	0
0	1	0	0	0	0	NORM	DCR	1/10	2F	IN	IN	NO	NO	1	0	0	0	0	1	1
0	0	0	0	0	1	NORM	PCR	10	2F	OUT	IN	NO	NO	1	1	0	1	1	0	0
0	0	0	1	0	0	NORM	PCR	10	2F	IN	OUT	NO	NO	1	1	0	0	0	1	1
0	0	0	1	0	0	NORM	PCR	1/10	3F	IN	IN	NC	NC	0	1	0	0	0	1	1
0	1	0	0	0	0	NORM	PCR	1/10	3F	IN	IN	NC	NC	1	0	0	0	1	0	0
1	0	0	1	1	0	NORM	PCR	1/10	2F	IN	IN	NO	NO	1	0	1	1	0	1	0
0	0	1	0	1	0	INV	PCR	1/10	2F	IN	IN	NO	NO	0	1	1	0	1	0	1
1	0	1	0	0	0	INV	PCR	1/10	2F	IN	IN	NO	NO	0	1	0	0	1	0	1

PWR OFF	UNBLK KEY	52B PWR	DTT KEY	EXT VOICE	INT VOICE	JU1 LINK	JU2 LINK	JU3 LINK	JU4 LINK	S1 FRONT HL	S2 PANEL SH	S3 SWITCH SL	CONT *HI	CONT *LO	D5 TX KEY	D4 VOICE KEY	D3 SHFT LO	D2 SHFT HI	D1 HL KEY
0	0	0	0	0	0	NORM	PCR	1/10	2F	0	0	0	0	1	0	0	1	0	0
0	0	0	0	0	0	NORM	PCR	1/10	2F	0	0	1	1	0	0	0	0	1	0
0	1	0	1	0	0	NORM	PCR	1/10	2F	0	1	0	1	0	0	0	0	1	0
0	0	0	0	0	0	NORM	PCR	1/10	2F	1	0	0	0	1	0	0	1	0	1

█ Link Change

* Used for G01, G03 Only

Table 10-3 Truth Tables for TCF-10B Keying Modules. (G03 - shift up to trip)

Figure 10-2. TCF-10B Keying PC Board (1606C50S).

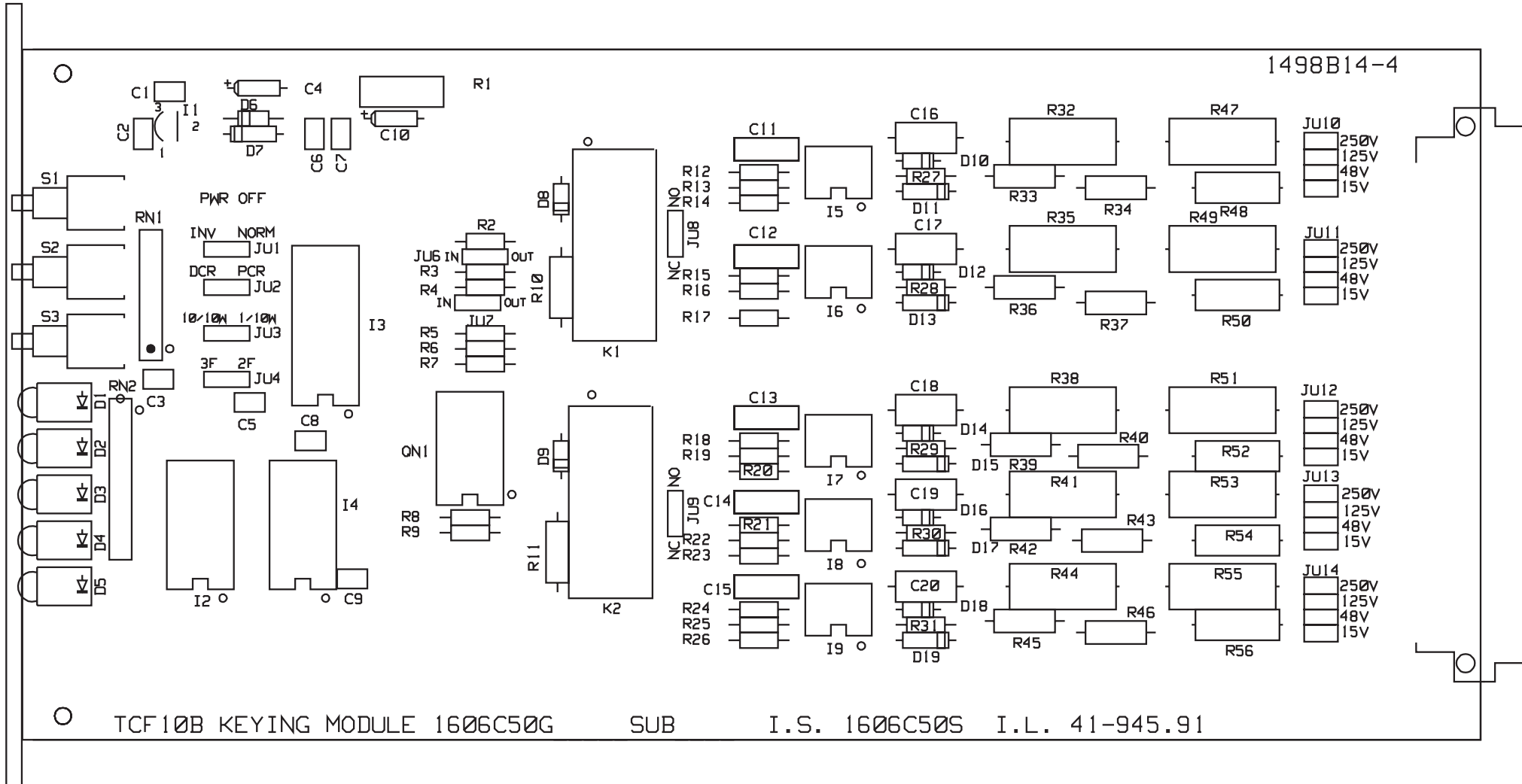

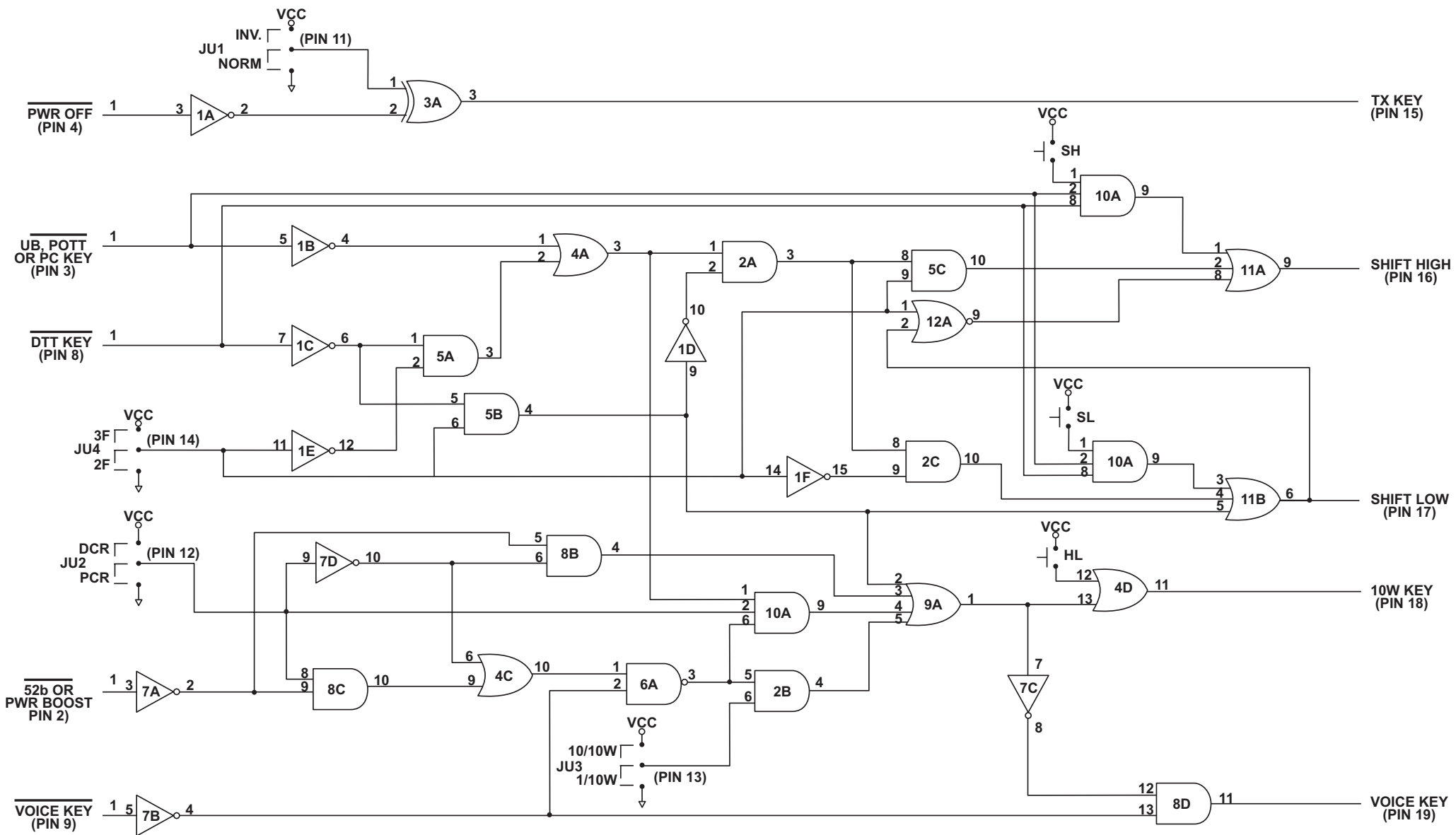
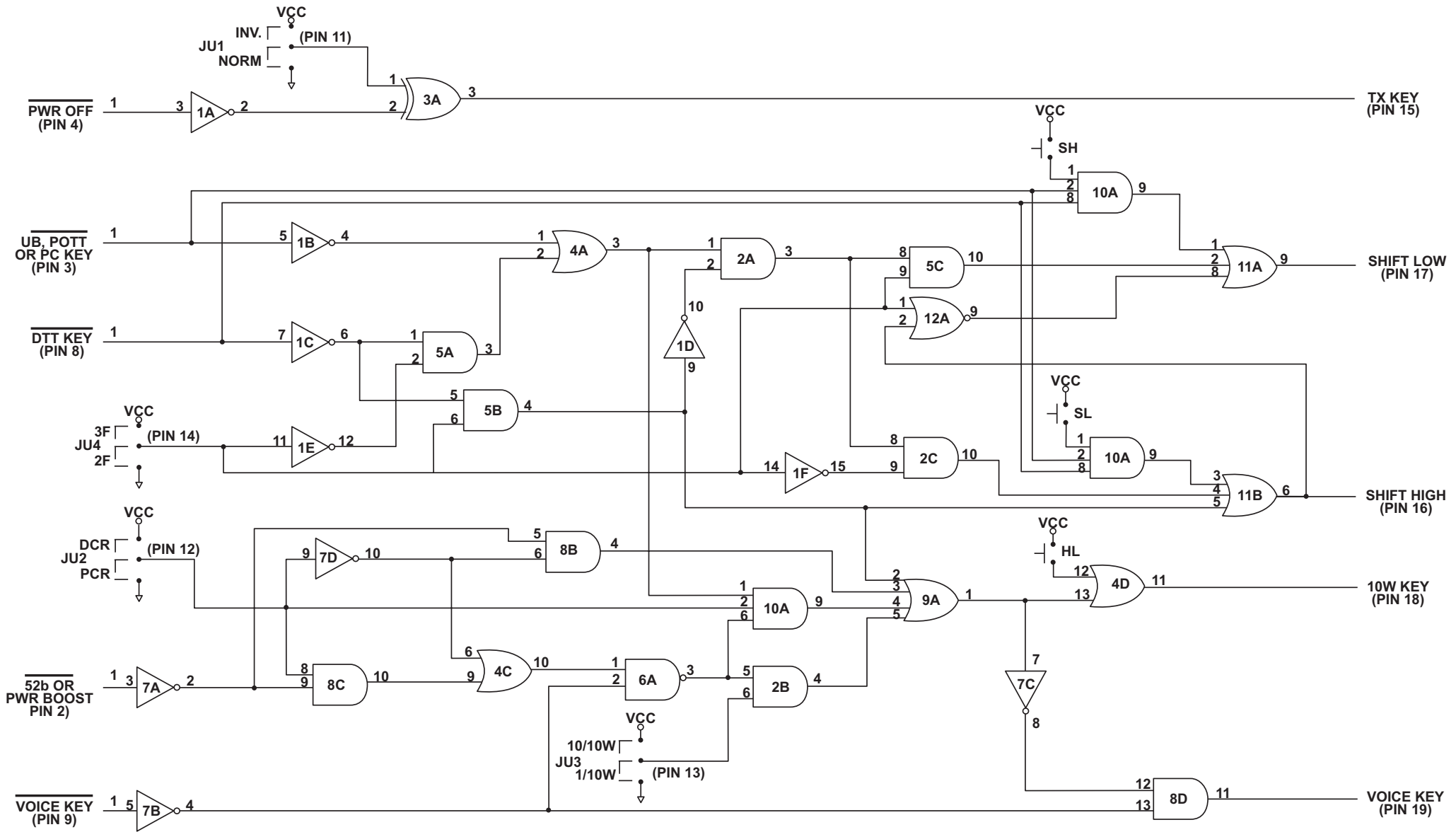

Figure 10-3. TCF-10B Keying Module Internal Logic G01 Shift down to trip

Figure 10-4. TCF-10B Keying Module Internal Logic G03- Shift up to trip



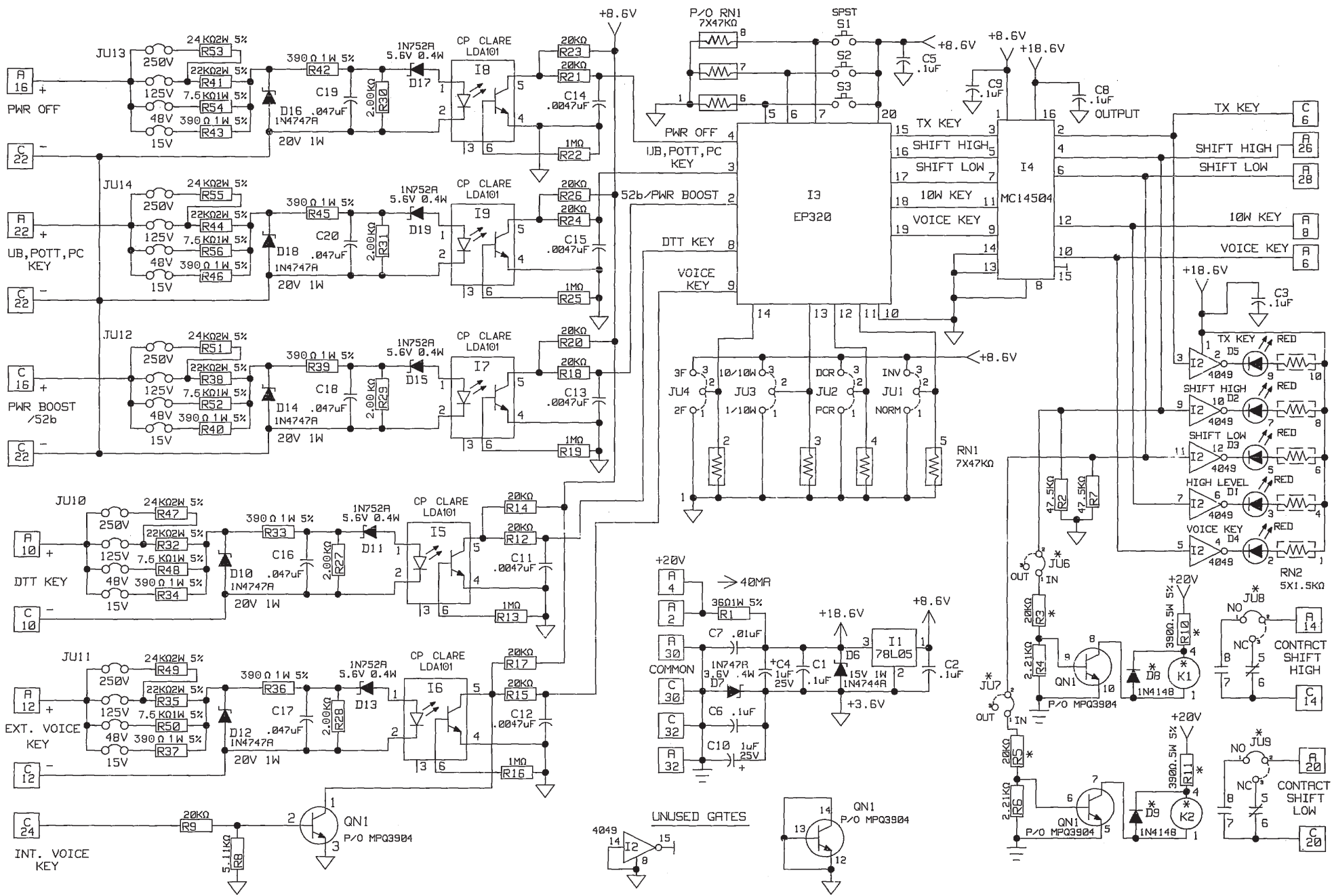

Figure 10-5. TCF-10B High Threshold Keying Schematic (1606C50-6).

Chapter 11. Transmitter Module

Table 11–1. C020-TXMMN Styles and Descriptions.

Schematic	C030-TXMMN-2
-----------	--------------

Group	Description
001	TRANSMITTER 2- OR 3-FREQUENCY
102	TRANSMITTER 2- OR 3-FREQUENCY W/Trip Test Unit

11.1 Transmitter Module Description

The function of the TCF–10B Transmitter Module is to provide the RF signal which drives the 10W PA Module. The Transmitter’s frequency range is from 30 kHz to 535 kHz, programmable in 0.1 kHz (100 Hz) steps by four rotary switches on the Transmitter. The Transmitter is slaved to a crystal oscillator.

The TCF–10B Transmitter Module operates from keyed inputs (set by jumpers at the Keying Module):

- High-Level Key
- Any Transmitter Key
- Voice Key
- Shift High (TCF–10B only)
- Shift Low (TCF–10B only)

The Transmitter Module also operates with a signal from the Optional Voice Adapter Module:

- AM Voice

The Transmitter Module operates with either no shift or one of three different frequency shifts, selectable by a four-position DIP switch (S5).

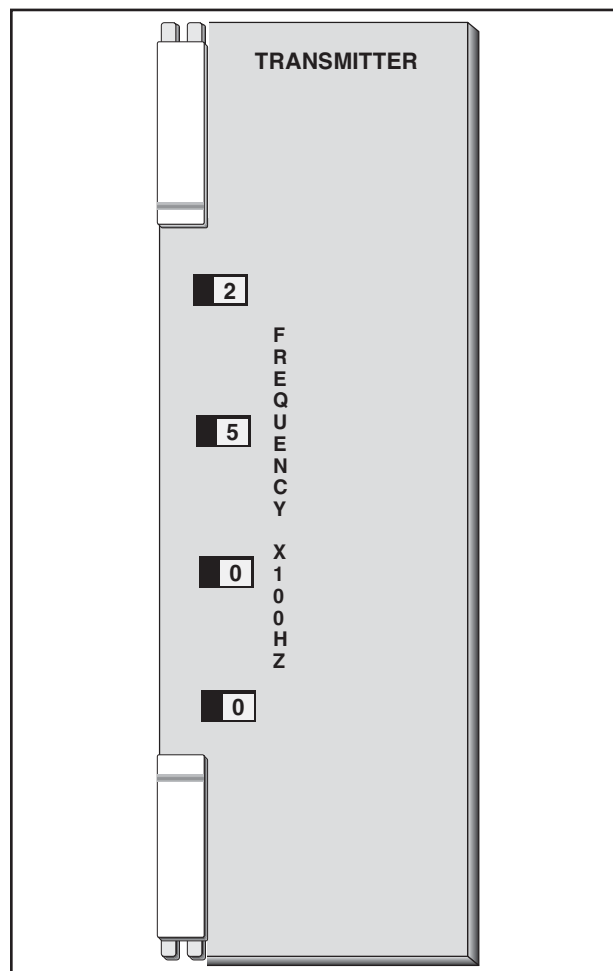

Figure 11–1. Transmitter Module – Front Panel.

11.1.1 Transmitter Control Panel

(This panel is shown in Figure 11-1.)

Operator controls consist of four thumbwheel switches (with indicator windows), representing the frequency range:

- SW1 (x 100 kHz)
- SW2 (x 10 kHz)
- SW3 (x 1 kHz)
- SW4 (x 0.1 kHz)

After pulling the module, use a screw driver to set the thumbwheel switches: CW for higher frequency, CCW for lower frequency.

11.1.2 Transmitter PC Board

(The Transmitter PC Board is shown in Figure 11-2.)

Operator controls are as described below.

Potentiometers

- R13 Adjusts high-level (10W) output
- R12 Adjusts low-level (1W) output
- R14 Adjusts voice (4.3W) output level
- R11 Adjusts modulation of transmitter signal (peak-to-valley ratio of signal envelope)

Switch

- S5 Frequency-shift select

11.2 TRANSMITTER TROUBLESHOOTING

Should a fault occur in this module, call the factory for an RMA.

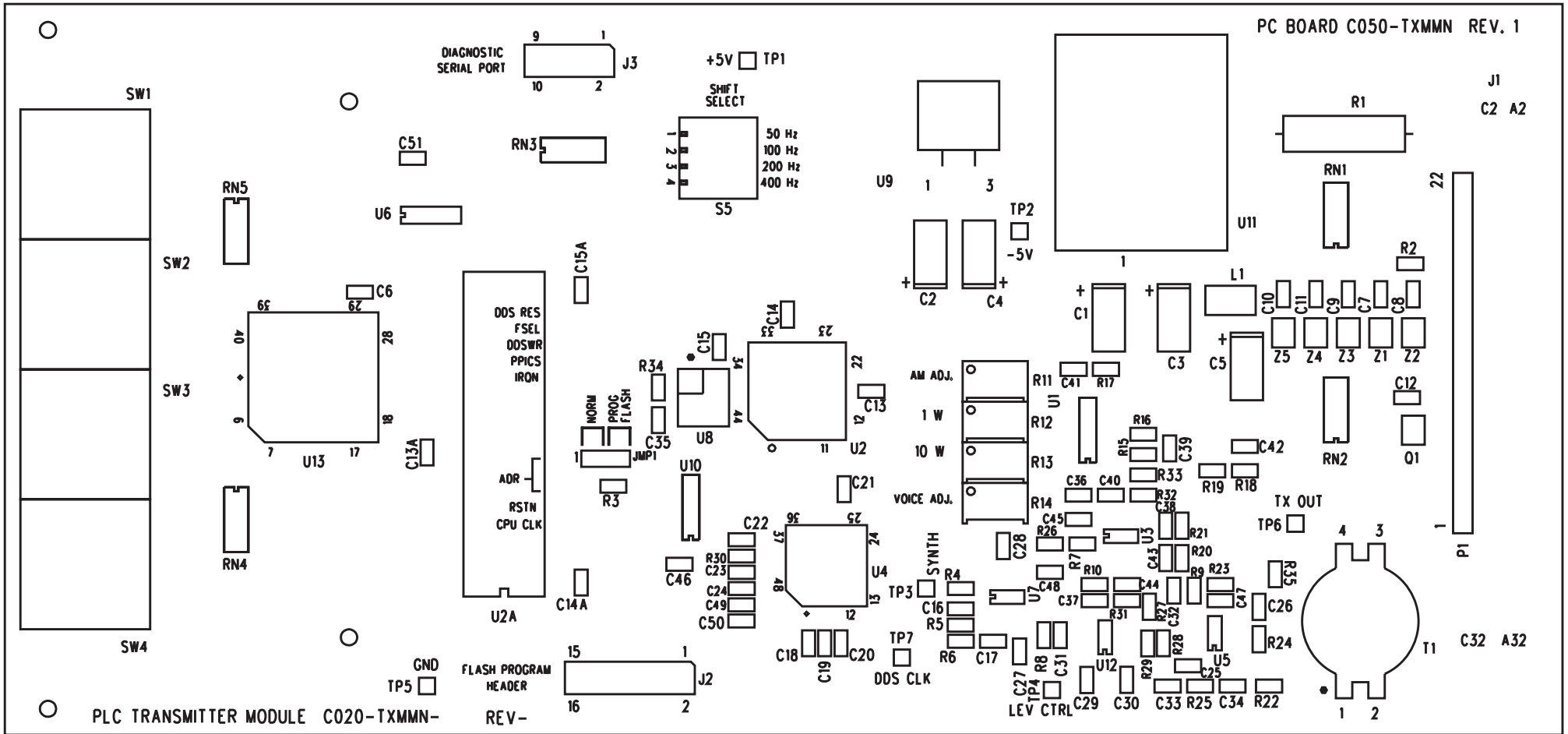
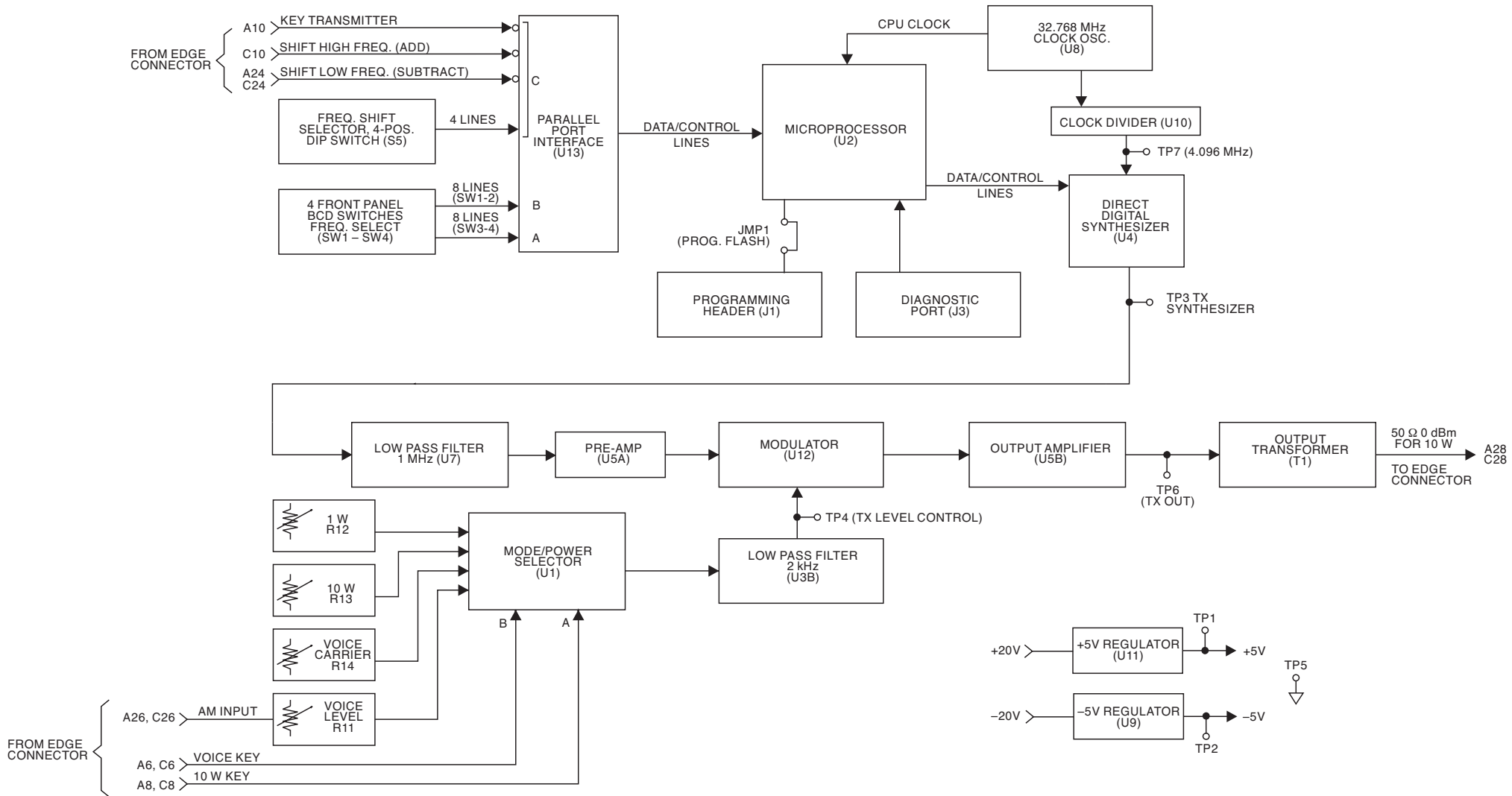

Figure 11-2. TC-10B/TCF-10B Transmitter Component location (C020-TXMMN).

Figure 11-3. TCF-10B Transmitter Block Diagram.



Chapter 12. 10W PA Module

Schematic	1606C33-21
-----------	------------

Table 12–1. 1606C33 Styles and Descriptions.

Group	Description
G01	WITH POWER ON RELAY

12.1 10W PA Module Description

The function of the TCF-10B 10 W PA Module is to amplify a 0 dBm (1mW) input to an output power level of 10W. You may also adjust the 10W PA for input power levels from 0.5mW to 2mW.

The 10W PA Module operates in a 30 to 535 kHz range without tuning. The amplifier has a fixed gain of approximately 49 dB (class A, complementary symmetry push-pull stage). Negative feedback is used to derive a nominal output impedance of 50Ω.

12.1.1 10W PA Control Panel

The front panel is shown in Figure 12–1. Operator controls are described here.

Potentiometer (R53) INPUT LEVEL SET

Adjusts power output level to 10W with 1mW input.

LED, TRANSMIT, RF Power Indication, Red (D6)

Test Jacks

- INPUT (TJ1)
- COMMON (TJ2)

Relay alarm for RF voltage

12.1.2 10W PA PC Board

(The 10W PA PC Board is shown in Figure 12-2.)

Operator controls consist of a Jumper (JU1) for the transmitter on Alarm Relay (NO/NC). The relay is energized if RF power (1W or more) is present.

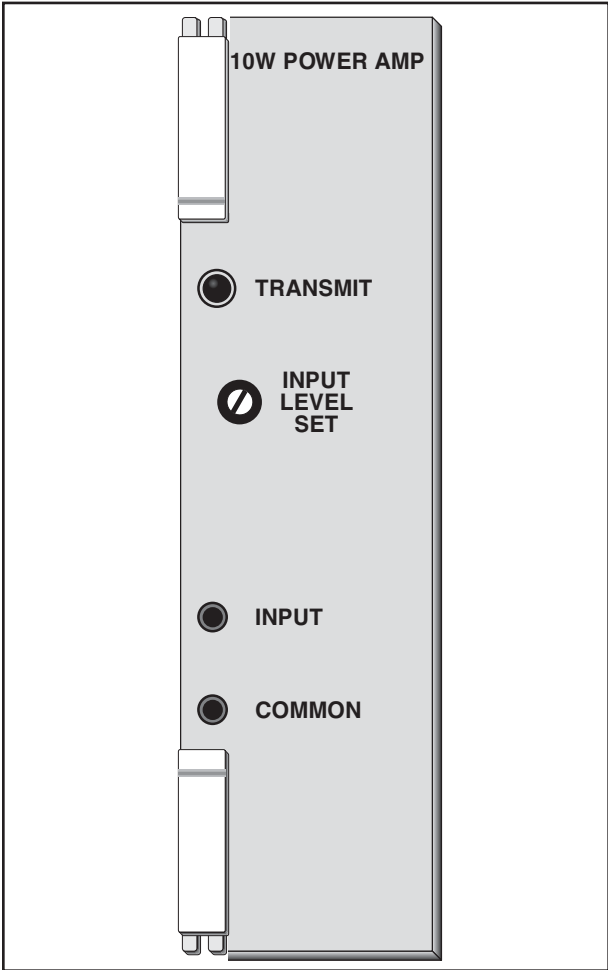

Figure 12–1. 10W PA Module – Front Panel.

12.2 10W PA Circuit Description

The function of the 10W PA Module (see Figure 12-3, Schematic 1606C33S) is to amplify a 0 dBm (1mW) input to an output power level of 10W. The input from pins C28/A28 passes thru a 700 kHz low pass filter (LPF) consisting of L1 and C1. Potentiometer (R53), labeled “INPUT LEVEL SET” on the front panel, is used to adjust the power level to 10W output with 1mW applied at the input.

The 10W PA Module operates in a 30 to 535 kHz range without tuning. The amplifier has a maximum gain of approximately 49 dB (class A, complementary symmetry push-pull stage). Negative feedback is used to derive a nominal output impedance of 50Ω.

All bypassing is done to common (pins A30/C30, A32/C32). Transistors QN1, QN2 and QN3 are 14 pin DIPs, each containing four individual transistors; QN1 is PNP, while QN2 and QN3 are NPN.

The LPF output drives the amplifier QN1 and QN2. QN1A/QN1B and QN2A/QN2B are configured as a differential amplifier, while QN1C and QN2C are constant current sources. The input signal is applied to the bases of QN1A and QN2A. Negative feedback is applied to the bases of QN1B and QN2B. At the positive side (QN2), the differential output from QN2A and QN2B is amplified by QN2D and Q2. At the negative side (QN1), the differential output from QN1A and QN1B is amplified by QN1D and Q1. The positive side power output transistor (Q6) is driven by Q5; the negative side power output transistor (Q7) is driven by Q4.

The no-load feedback is from transformer (T1) back thru the RC network of R21, C7, C2, C5 and R18 to the junction of R16 and R17, for the purpose of stability. The loaded feedback is derived from a sampling resistor (R33, R35, R36, R37, R38, and R39, all in parallel) and fed back thru C28, C29 and R23. The overall no-load voltage gain is approximately 282. The overall loaded voltage gain is approximately 141. The partial loaded gain, between C28/A28 and the primary of T1, is approximately 38.

The alarm circuit (loss of RF signal condition) consists of QN3, Q8, K1 and associated components. The RF signal is monitored by C22, at T1 pin 1. The signal sample is amplified in QN3A and fed to QN3B and QN3C (QN3B and QN3C are configured as diodes). A voltage doubler is formed from C30, QN3C and QN3B. The output of QN3B drives QN3D, via R44 and R45. QN3D is saturated for an input of 1W to C22 (with reference to T1 secondary). As QN3D saturates, Q8 conducts, driving the front panel LED (D6, power monitor), causing K1 to energize (or de-energize), indicating loss of signal condition. Jumper JU1 allows the selection of an open circuit or a closed circuit for the loss of signal condition.

The +20 Vdc line (leading to the alarm circuit, etc.) is filtered by C10, C11, L2, L4, C19, C20 and



CAUTION

THE 10W PA IS, BASICALLY, AN OP-AMP PROVIDING VERY HIGH GAIN WITH NEGATIVE FEEDBACK. TRANSISTORS Q1 THROUGH Q5, Q6, AND Q7 ARE THERMALLY CONNECTED, I.E., THEY ARE MOUNTED ON THE SAME PART OF THE HEAT SINK. ANY FAILING TRANSISTOR MAY AFFECT OTHER TRANSISTORS. CHECK EACH TRANSISTOR SEPARATELY. IF NO FAULTS ARE FOUND, CHECK OTHER COMPONENTS.

BE CAREFUL NOT TO MISPLACE SCREWS, SPRING WASHER OR INSULATING WASHER USED TO MOUNT Q1 THROUGH Q8. DAMAGED SCREWS OR INSULATORS SHOULD NOT BE USED.

C21. The -20 Vdc (leading to C2/C4) is filtered by C12, C13, L3, C16, C17, C18 and L5.

12.3 TROUBLESHOOTING

To check individual transistors, e.g., Q1 thru Q8, QN1, QN2 and QN3, remove them first from the PC Board. Ohmmeter measurements of the transistors while in the PC Board are misleading because of other paths on the board.

You may remove the heat sink by unscrewing the four (4) corner screws and the hold-down screws for Q1 thru Q8. The 10W PA Module can operate at no-load conditions without the heat sink for short periods of time while you are troubleshooting.

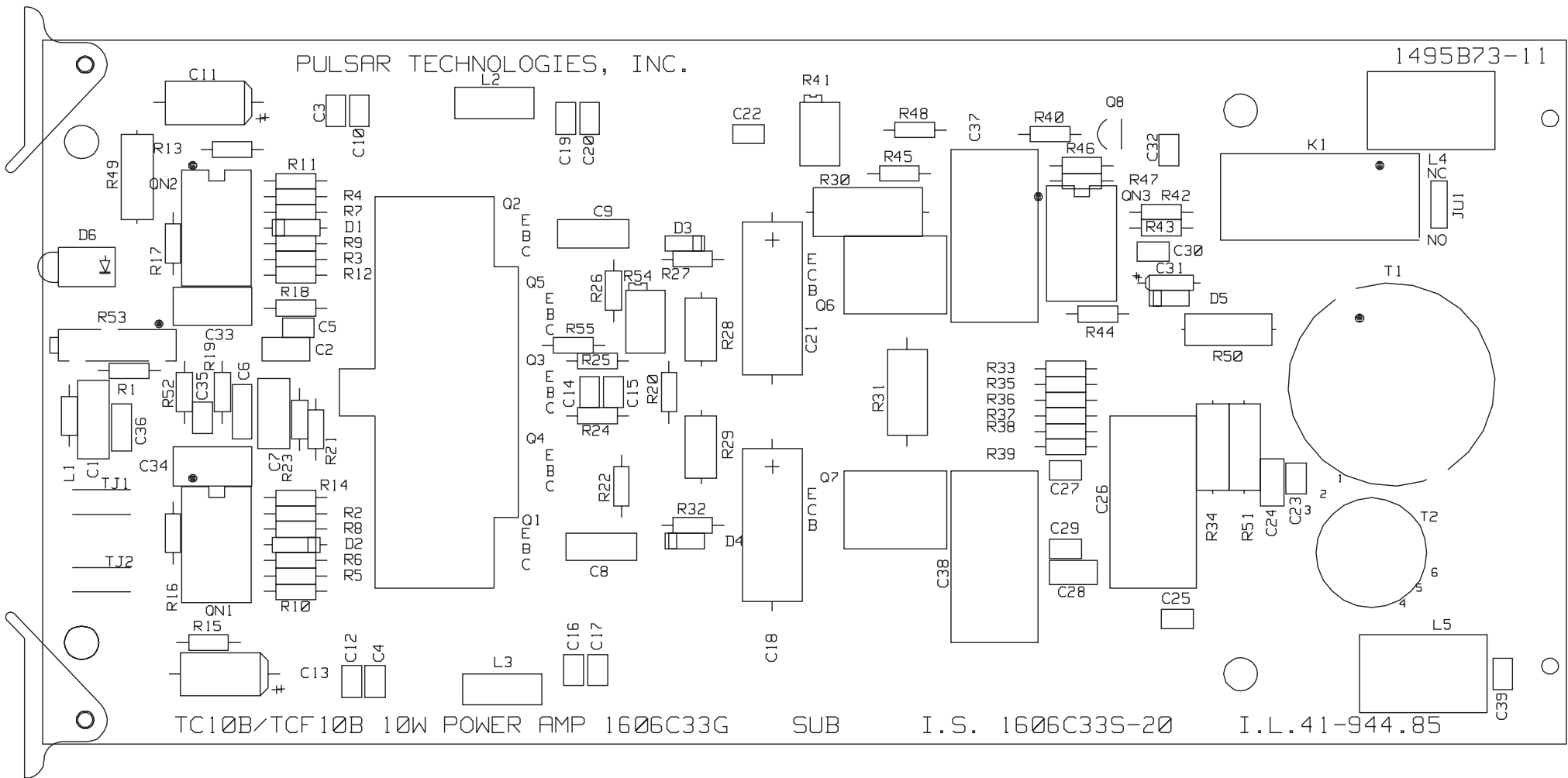
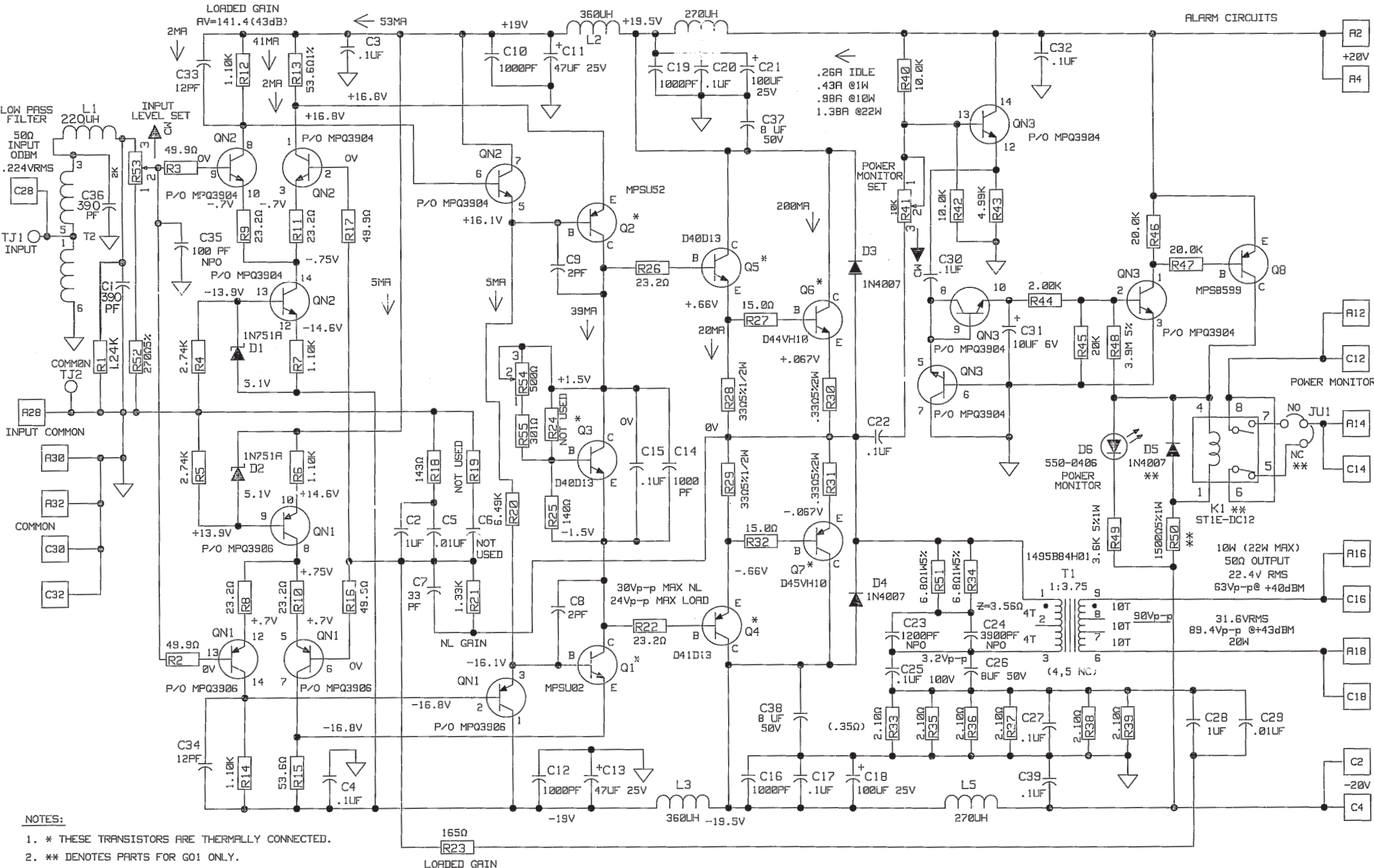

Figure 12-2. TC-10B/TCF-10B 10W PA Component location (1495B73).

Figure 12-3. 10W PA Schematic (1606C33).



- NOTES:
1. * THESE TRANSISTORS ARE THERMALLY CONNECTED.
 2. ** DENOTES PARTS FOR G01 ONLY.
 3. RESISTORS ARE 1/4 W 1% UNLESS NOTED.
 4. ALL VOLTAGES WITH RESPECT TO COMMON (∇).

Chapter 13. RF Interface Module

Table 13–1. 1609C32 Styles and Descriptions.

Schematic	1609C32-9
-----------	-----------

Group	Description
G01	RF Interface

13.1 RF Interface Module Description

The RF Interface Module, used with the TCF–10B, has several functions:

- Receives RF input from 10W PA Module.
- Matches output impedance at 50, 75, or 100Ω.
- Low-pass filter covers RF spectrum up to 550 kHz.
- Permits 2- or 4-wire operation.
- Protects against line surges with a gas tube device.

13.1.1 RF Interface Control Panel

(This panel is shown in Figure 13-1.)

Operator controls consist of Test Jacks:

- TJ1 Line In
- TJ2 Line Common
- TJ3 Receiver In
- TJ4 Receiver Common

13.1.2 RF Interface PC Board

(The RF Interface PC Board is shown in Figure 13-2.)

Operator controls are as follows:

Matching Impedance Jumpers

- JU4 50Ω
- JU3 75Ω
- JU2 100Ω

2-wire or 4-wire RF Termination

- JU1/JU5 “IN” 2-wire
- JU1/JU5 “OUT” 4-wire

Attenuator Override Jumper (JU6)

- NORM Sensitivity 70Vrms at 5,000Ω
- HIGH Sensitivity 17Vrms at 1,000Ω

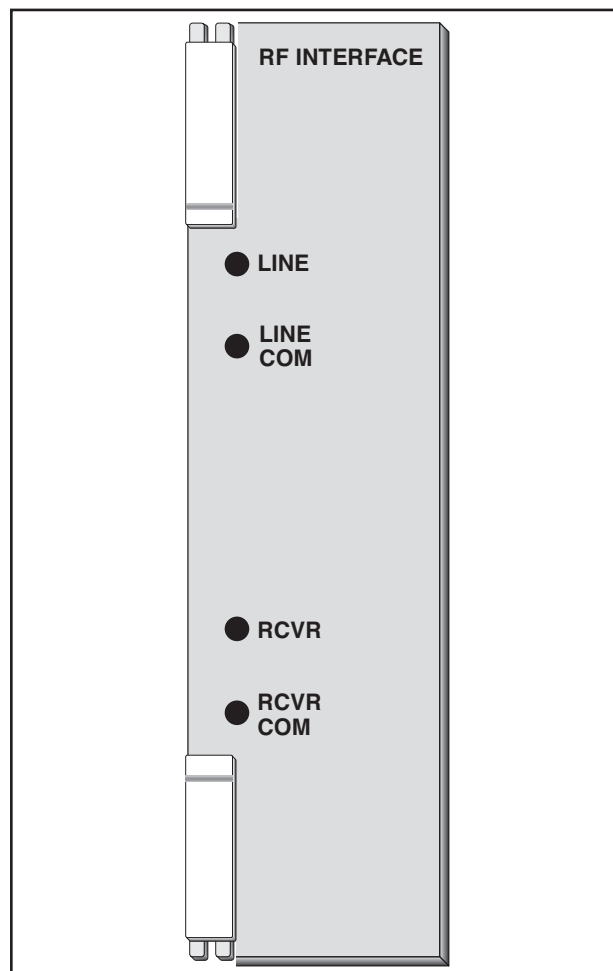

Figure 13–1. 10W PA Module – Front Panel.

13.2 RF Interface Circuit Description

This module receives RF input from the 10W PA Module at pins A16/C16 and A18/C18, and feeds the power through a balanced low-pass filter with a 550 kHz cutoff (L3, L4, L1, L2 and associated components). RF is fed through transformer T1, for matching 50 Ω (JU4), 75 Ω (JU3), or 100 Ω (JU2) resistance to the RF line output (45Vrms maximum) at pins 12A/12C and 10A/10C, which provide the two-wire UHF (J1) connection on the Rear Panel.

Four-Wire Receiver input is provided at pins 24 A/C and 22 A/C via the 4-wire BNC (J2) connector on the Rear Panel. Jumpers JU1 and JU5 simultaneously connect the four-wire Receiver input to RF line output:

- IN settings for 2-wire operation
- OUT settings for 4-wire operation

Isolation transformer T2, together with series resistor R1, forms an attenuator with 13 dB loss. Receiver input (at pins 28 A/C) is adjusted by jumper JU6:

- When in the NORM position, Receiver maximum input is 70Vrms at 5,000 Ω
- When in the HIGH position, JU6 overrides the attenuator, providing lower input impedance (Receiver maximum input is 17Vrms at 1,000 Ω).

13.3 RF Interface Troubleshooting

With the PC Board plugged into the chassis, you can monitor the voltage output to the RF line at TJ1 and TJ2. You can monitor receiver input at TJ3 and TJ4.

Should a fault occur in the RF Interface Module, you can remove the PC board and check the components by conventional means.

13.3.1 Capacitors

Remove from the circuit with jumpers JU2, JU3 and JU4 and check for shorts, dissipation factor, and capacitance. (Perform checks using a signal of 10 kHz or higher.)

13.3.2 Inductors

Check with an ohmmeter.

13.3.3 Transformers

Check for open circuits.

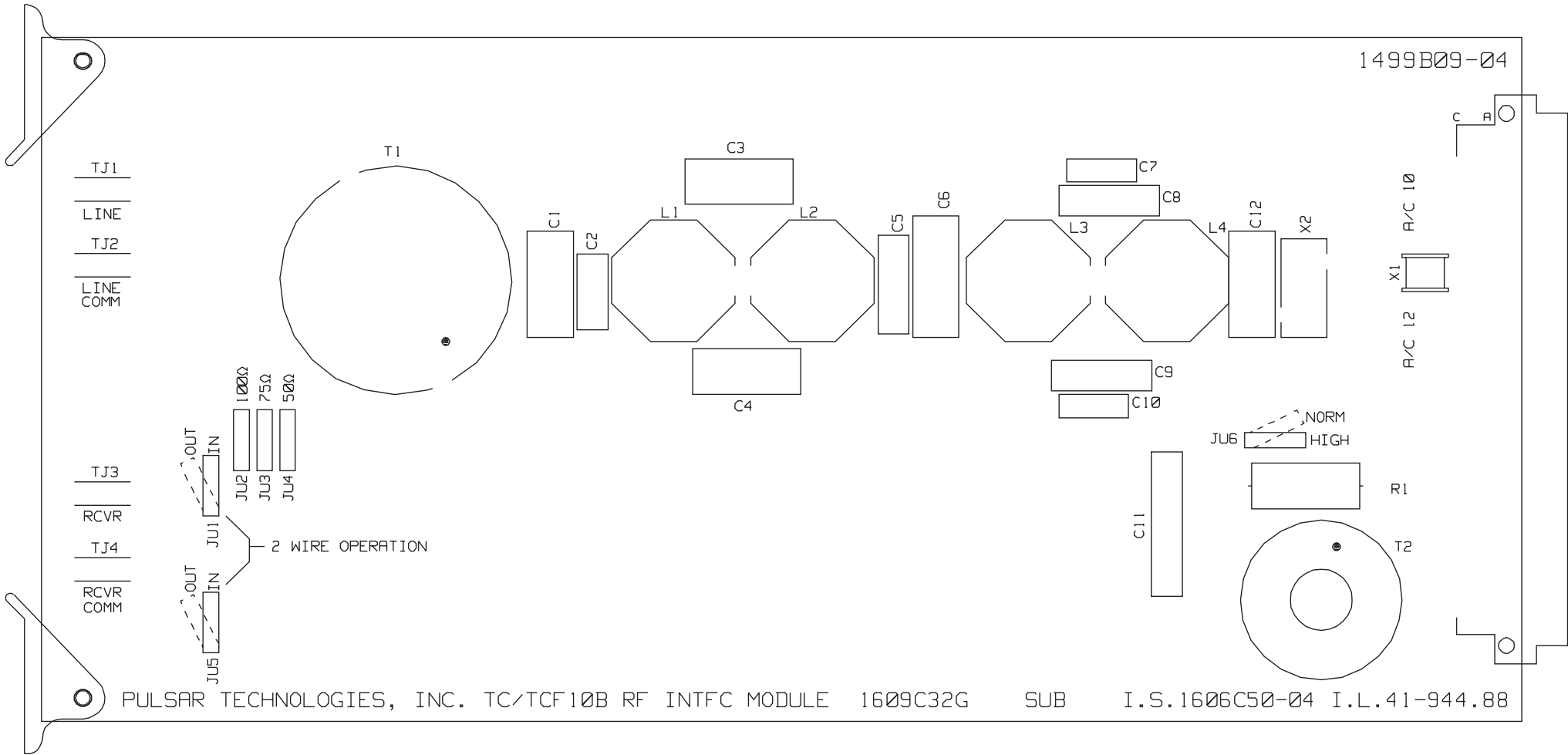
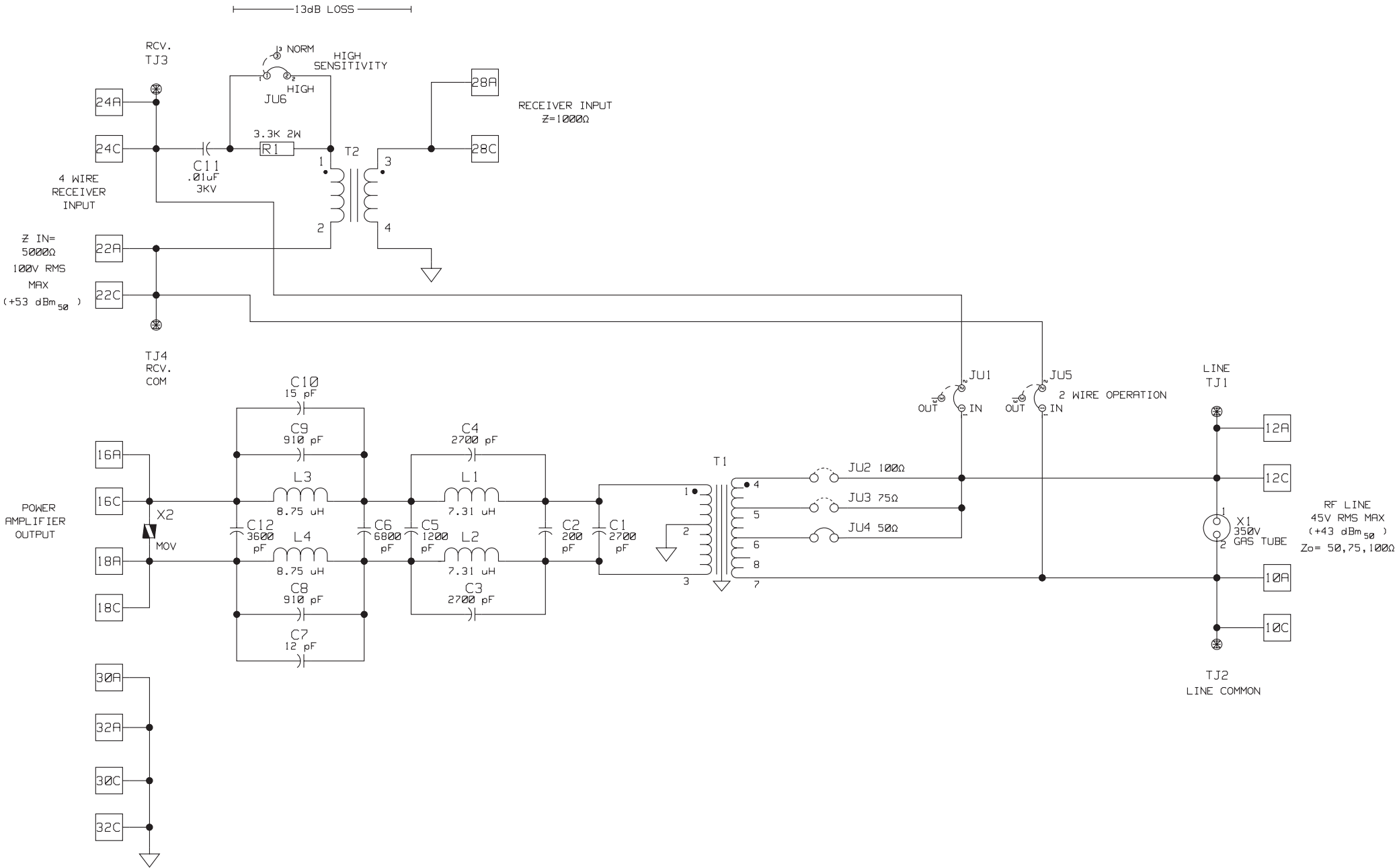

Figure 13-2. TC-10B/TCF-10B RF Interface Component location (1609C32).

Figure 13-3. TC-10B/TCF-10B RF Interface Schematic (1609C32).



Ch. 14 Universal Receiver Module

Table 14–1. Receiver Styles.

The Universal Receiver is pin-for-pin compatible with the previous version of the Receiver and Discriminator modules.

Function	Style
Receiver/FSK Discriminator	CO20-RXVMN-202
Universal Receiver	CO20-RXVMN-203

14.1 Receiver Module Description

The Universal Receiver Module comes in two styles/versions: the Receiver/FSK Discriminator for the TCF–10B and the Receiver/AM Detector for the TC–10B. To change versions, simply push switch SW1-1.

The Receiver Module comprises two boards. The main (top) board contains all the circuitry required for the filtering and A/D conversions necessary to process the incoming RF signal. The auxiliary (bottom) board contains DC-voltage regulators and components specific to the Receiver/FSK Discriminator.

The module’s double board combination slides into the same slots as the previous Receiver and

Discriminator modules. The single Universal Receiver with 2 boards replaced the 2 previous separate modules (Receiver, 1606C32GXX & Discriminator, 1606C51GXX). With the new Universal receiver, however, you do not need extender cards to make adjustments or change settings. You can perform all necessary settings and adjustments directly on the front panel (see Figure 14-2).

The Receiver Module is driven by the output of the RF Interface Module. The output of the Receiver Module drives the necessary output module. The (primary) output module for the TCF-10B is the Receiver Logic Module, as shown in Figure 14–1. The module’s audio output drives the optional Voice Adapter Module, if it is installed.

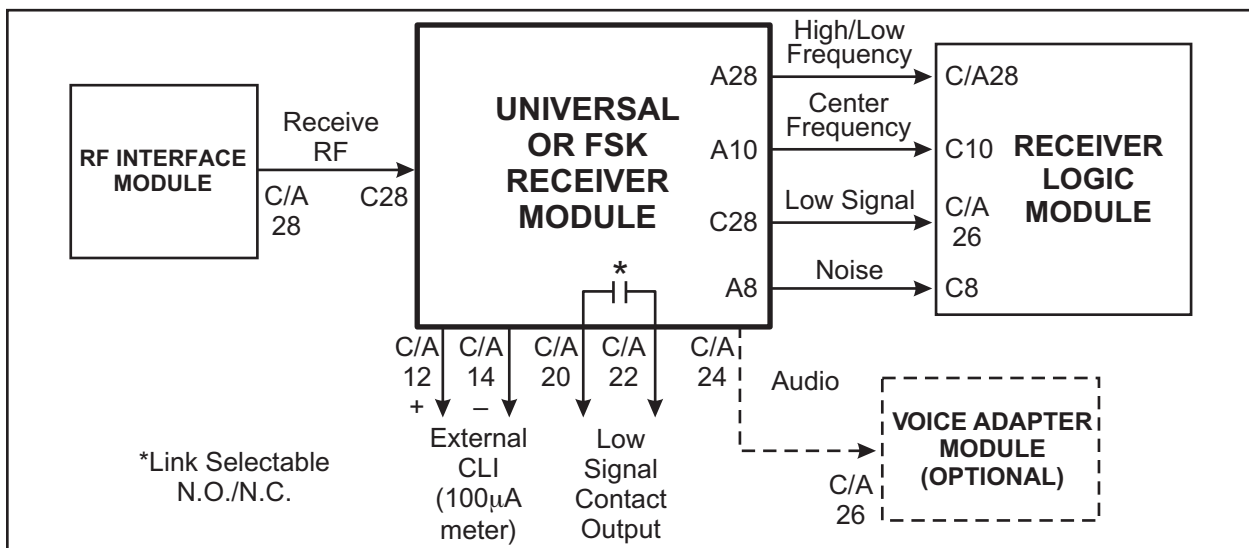

Figure 14–1. Receiver / FSK Discriminator Module — Simplified Signal Flow Diagram.

The receiver outputs are shown below.

Receiver/FSK Discriminator:

- Noise
- Low Signal
- Center Frequency
- High/Low Frequency

14.2 Front Panel Controls and Displays

The controls and displays, for the Universal Receiver, along with the two alarm indicators at the bottom of the panel are shown in Figure 14-2. These controls and displays are described below. (Please see “Frequency & Sensitivity Setting” later in this chapter for setting instructions.)

Frequency Display

The frequency display is at the top right of the module’s front panel. It is a four- (4-) digit green LED numeric display. During normal operation, it shows the current receiving frequency. When in the “setting” mode, it displays instructions and various messages.

Carrier Level Indicator

The Carrier Level Indicator is directly beneath the frequency display. It provides a tri-color bar graph showing a range of -20 to +10 dB, in 5 dB increments. There is also an external CLI circuit to drive a remote 0-100 μ A external meter, 10 to 350 Vdc.

Push-button Controls

The recessed, push-button controls are as follows:

CANCEL/RAISE—When in the “Setting” mode, this button raises the frequency, sensitivity, or external CLI settings. It also lets you skip the sensitivity setting option after you set the frequency.

LOWER—This button lowers the frequency, sensitivity, or external CLI settings.

SET—This button initiates the “Setting” mode and accepts the displayed settings,

Alarms

The alarm for the FSK receiver is:

LOW SIGNAL—Low signal alarm relay: selectable normally open (NO) or normally closed (NC) contact; relay is energized when RF signal is present and above minimum sensitivity setting. Use J3 on the bottom board to set the NO or NC position please see Figure 14-3.

14.3 Specifications

The Universal Receiver Module’s technical specifications are shown in Table 14-2.

The module’s FSK frequency spacing specifications are shown in Table 14-3.

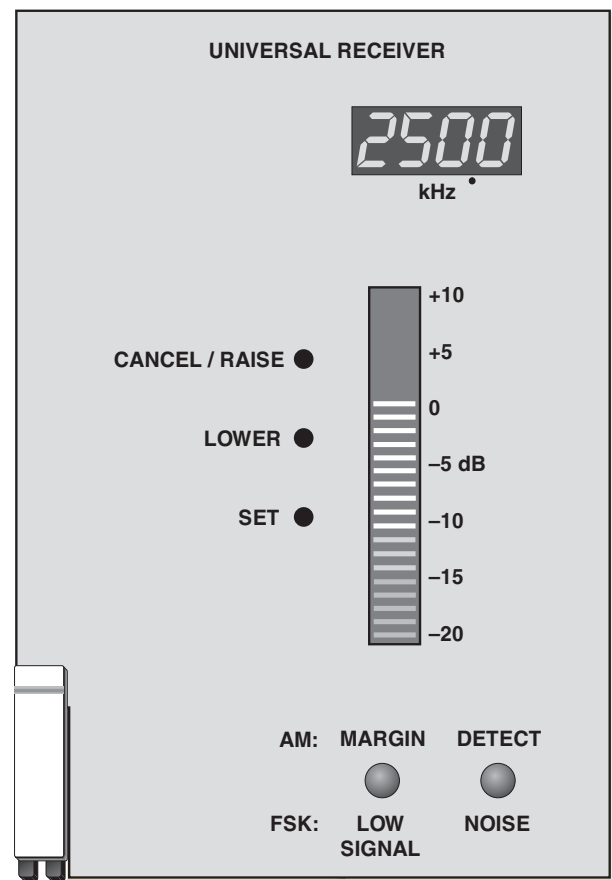

Figure 14-2. Universal Receiver/FSK Receiver Front Panel.

Table 14–2. Receiver System Specifications.

Frequency Range	30 to 535 kHz, in .5 kHz increments
4-Wire Receiver Input Impedance	5,000Ω or 1,000Ω (high sensitivity strapping)
Modulation CO20-RXVMN-202	Frequency Shift Keyed (FSK), two or three frequency
Frequency Shift	Narrow shift (± 100 Hz) Wide shift (± 250 Hz) Extra Wide Shift (± 500 Hz)
Nominal Bandwidths	Narrow Band (380 Hz at 3 dB points) Wide Band (800 Hz at 3 dB points) Extra Wide Band (1600 Hz at 3 dB points)
Receive Sensitivity (Narrow, Wide Band, or Extra Wide Band)	22.5mV (min) to 70V (max) Standard Setting 5mV (min) to 17V (max) High setting
CHANNEL SPEED*	
(FSK)	
Narrow Band (380 Hz)	7.5ms
Wide Band (800 Hz)	5.9ms
Extra Wide Band (1,600 Hz)	4.7ms

**Receiver set for 15 dB margin, no time delay, solid state output)*

Table 14-3. FSK Frequency Spacing Specifications (Minimum).

Narrow Band	Unblock or Transfer Trip	1 way, 500 Hz 2 way, 1,000 Hz
Wide Band (Narrow or Wide Shift)	Unblock or Transfer Trip	1 way, 1,000 Hz 2 way, 2,000 Hz
	Phase Comparison (60 Hz sq. wave keying)	1 way, 1,500 Hz 2 way, 3,000 Hz
	Phase Comparison (60 Hz 3ms pulse keying)	1 way, 2000 Hz 2 way, 4,000 Hz
Extra Wide Band	Unblock or Transfer Trip	1 way, 2,000 Hz 2 way, 4,000 Hz
	Phase Comparison (60 Hz sq. wave keying)	1 way, 2,000 Hz 2 way, 4,000 Hz
	Phase Comparison (60 Hz 3ms pulse keying)	1 way, 2,000 Hz 2 way, 4,000 Hz
All Voice Applications	Minimum Channel Spacing	2-way, 4,000 Hz

14.4 Switch Settings

Tables 14–4 and 14–5 show the DIP switch settings for the Receiver/FSK Discriminator.

Table 14–4. Universal Receiver (SW1 settings).

SWITCH SETTING	OFF	ON
SW1-1	FSK	AM
SW1-2	NO VOICE ADAPTER	VOICE ADAPTER
SW1-3	DTT (50 ms D.O. on noise clamp)	UB (10 ms D.O. on noise clamp) UB 2F or 3 Frequency
SW1-4	DIRECTIONAL COMPARISON RELAYING	PHASE COMPARISON RELAYING
SW1-5	SHIFT DOWN TO TRIP 2F or 3F	SHIFT UP TO TRIP 2F only

Note For Direct Transfer Trip Applications:

It is recommended that the Receiver Logic pre-trip time delay be for at least a minimum of 4 ms, preferably at the maximum the power system will allow for critical clearing times. Refer to Receiver Logic Section for settings.

Table 14–5. Universal Receiver (SW1-1 set to the OFF position).

SW1-6	SW1-7	SW1-8	BANDWIDTH	SHIFT	2F/3F
OFF	OFF	OFF	380 Hz	100 Hz	2F
OFF	OFF	ON	800 Hz	250 Hz	2F
OFF	ON	OFF	1600 Hz	500 Hz	2F
OFF	ON	ON	800 Hz	250 Hz	3F
ON	OFF	OFF	1600 Hz	500 Hz	3F
ON	OFF	ON	800 Hz	100 Hz	2F
ON	ON	OFF	1600 Hz	250 Hz	2F

14.5 Frequency & Sensitivity Setting

To change settings on the FSK receiver, complete the following sequence:

14.5.1. Push the SET button.

This causes the frequency display to begin flashing, indicating that the receiver is in the “setting” mode.

If you do not touch any of the buttons for approximately three minutes, the receiver exits the setting mode and reverts to the previous settings.

14.5.2. Set the frequency.

To keep the displayed frequency, press the SET button again.

To increase the frequency, push the CANCEL/RAISE button; to decrease it, push the LOWER button. Pushing either button once and releasing it raises or lowers the frequency by the minimum increment, 0.5 kHz. Holding down either button for more than two seconds increases the incrementing speed. If you exceed the maximum of 535 kHz, the display rolls over to the lower end, 30 kHz, and continues scrolling.

After you have the desired frequency displayed, release the button. The display once again flashes, indicating that it is still in the “setting” mode and has not yet accepted the new setting. Press the SET button to accept the frequency setting.

14.5.3. Set the sensitivity.

After you set the frequency, the display scrolls this message: "Set Sens?... – Hit Set or Cancel...".

To keep the current sensitivity setting, press the CANCEL/RAISE button.

To tell the receiver to automatically set the sensitivity based on an incoming remote signal, press the SET button. This sets the receiver for a 15 dB margin and calibrates the CLI meter to 0 dB. While the receiver is setting the sensitivity, the display scrolls the message: "Working...".

At first the bar graph is blank. Then it gradually ramps up until it reaches approximately 0 dB. The display then tells you whether the sensitivity level is okay or if there is a problem, such as a signal too weak to set for a minimum pickup level.

After the display gives the "-OK-" message, it then scrolls the message "Sens Adjust? – Hit Raise/Lower or Set when done..." Here, you can either accept the current setting or manually adjust the receiver sensitivity.

To accept the current setting, press the SET button. The receiver is now set for a 15 dB margin, and the CLI reads approximately 0 dB.

To manually adjust the receiver sensitivity up or down 10 dB, push the CANCEL/RAISE or LOWER button. The CLI will track accordingly and remain at that level to indicate the sensitivity is set that much below or above the 15 dB setting.

Sometimes the incoming signal may not be strong enough to raise the margin the full 10 dB. If this happens, the display says "Warning: signal too low for more gain - hit Set to continue.." When this happens, push the SET button. This lowers the sensitivity to an acceptable level and flashes the bar graph to remind you that you are still in the "setting" mode.

To accept the displayed level, push the SET button.

14.5.4. Set the external CLI.

Once you have completed the sensitivity setting, the display scrolls this message: "Set Ext CLI? – Hit Raise/Lower or Set when done..."

To calibrate the external CLI push the CANCEL/RAISE or LOWER button. The external CLI meter will move up and down accordingly. The external meter is a $100\mu\text{A}$ instrument. If it is calibrated in μA , the meter should be set to read $67\mu\text{A}$ (this is equivalent to 0 dB on the internal meter). The setting should be varied $3.3\mu\text{A}$ for each dB the margin adjustment has been raised or lowered from the 15 dB margin. If the meter is calibrated in dB, set the meter to read equal to the internal CLI meter.

To accept the displayed level, push the SET button.

This completes the FSK setting procedure.

Figure 14-3. TCF-10B Universal Receiver Location of SW1 Dip switch & J3

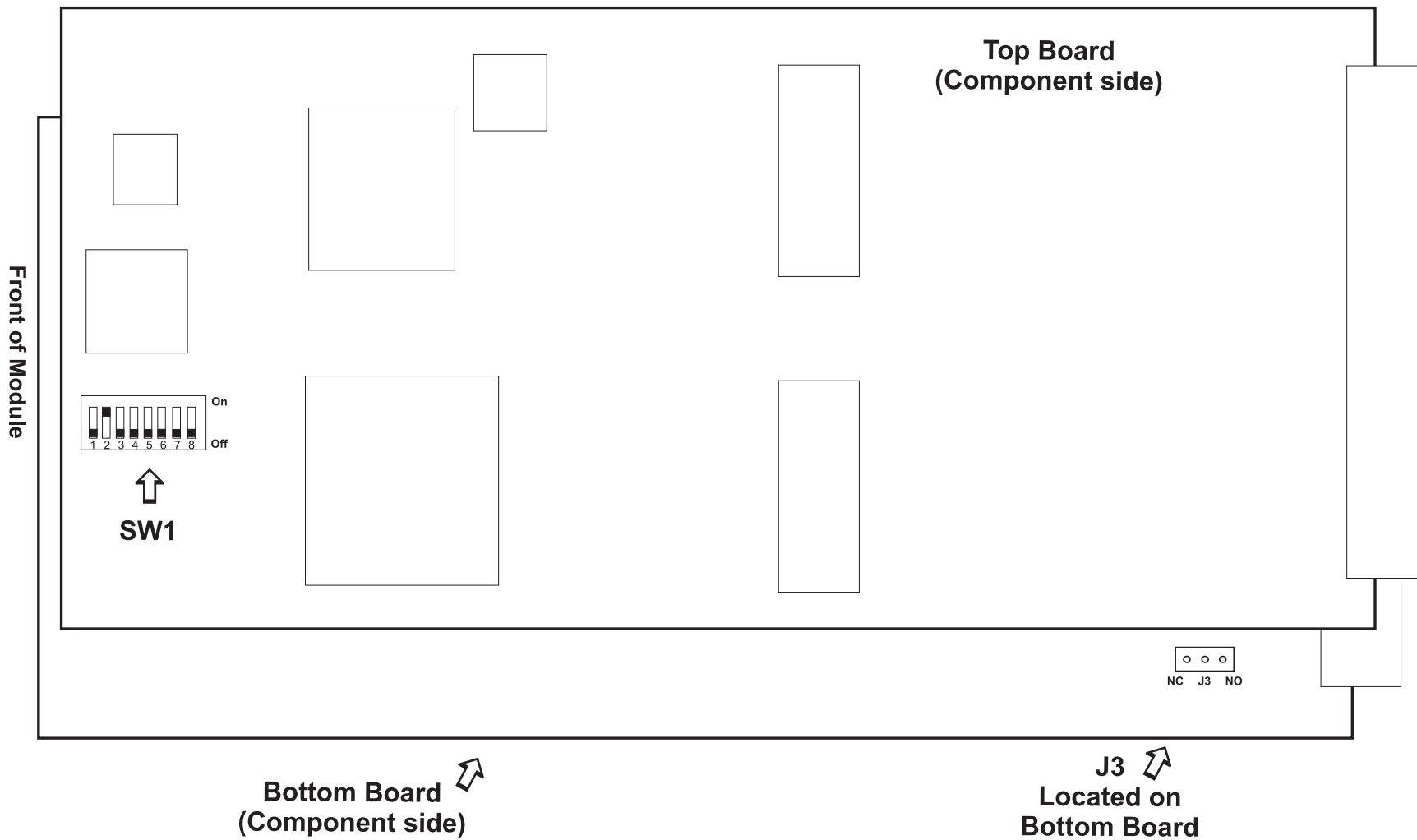

Chapter 15. Receiver Logic Module

Table 15–1. CF20-RXLMN-00X Styles and Descriptions.

Schematic CF30-RXLMN-6

Style	Description
004	2-FREQUENCY UB, PORTT, OR DTT
003	2-FREQUENCY PHASE COMPARISON
002	3-FREQUENCY DUAL UB/PORTT & DTT

15.1 Module Description

This version of the Receiver Logic Module — model CF20-RXLMN-00X — replaces the previous version — model 1606C52G0X — in all later TCF–10B carrier sets. This model is pin-for-pin compatible with the previous version, allowing for easy replacement/upgrading. It provides all of the same functions as the previous version, but with added flexibility.

Instead of just selecting the amount of time for a timer setting (e.g., trip delay, guard hold time, trip hold time), you now have the option of disabling, or not using, it. You can set any of the timers — or other options — for your application using the module’s three banks of DIP switches (see “Setting the DIP Switches for Your Application” later in this chapter).

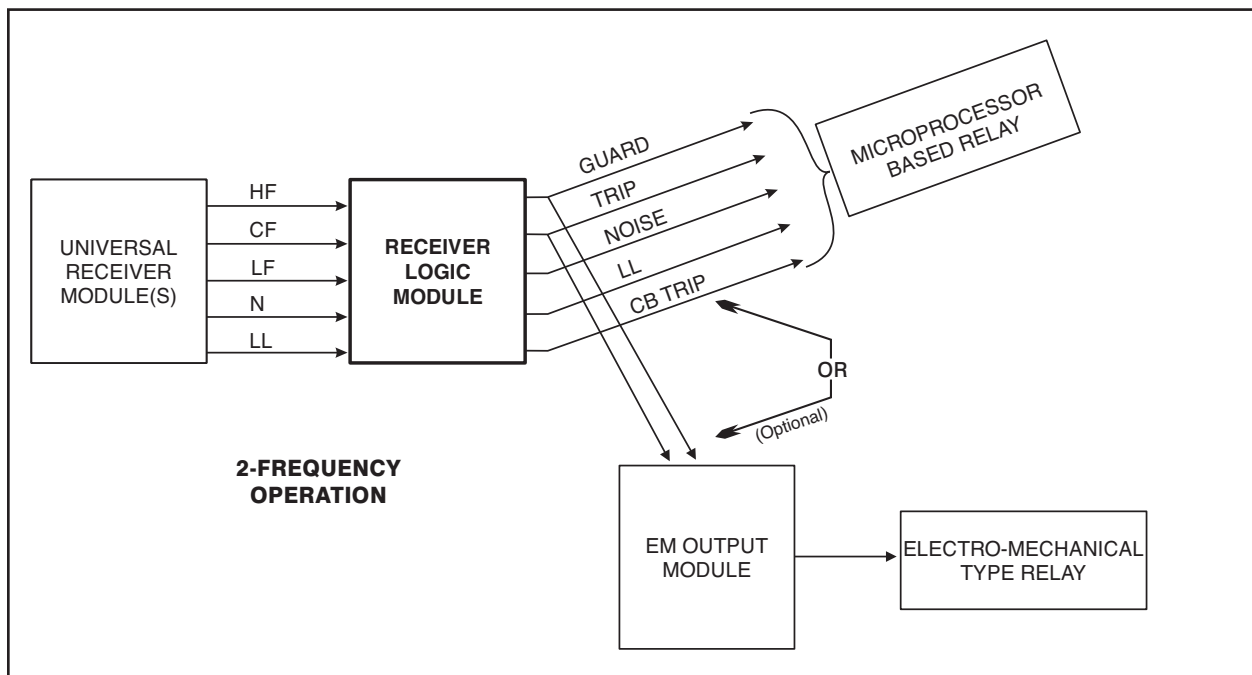

Figure 15–1. Simplified Signal Flow Diagram for 2-Frequency Operation.

The module now uses a programmable logic array, in the form of an EPLD plug-in chip, to control the module's logic functions. The chip that comes with each module is already programmed for the functions used in one of the following types of application:

- 2-Frequency Directional Comparison
- 3-Frequency Directional Comparison
- 2-Frequency Phase Comparison

The Receiver Logic Modules installed in all TCF-10B carrier sets are identical except for the EPLD plug-in chip controlling its logic functions and the front panel, which provides LEDs specific to one of the application types listed above.

Your TCF-10B Receiver Logic Module is shipped already customized for your application. That is, the front panel has the appropriate LEDs for your application and an EPLD chip that is already programmed with the relevant logic and functions. Likewise, the module's DIP switches are preset to the most secure settings for your application. For a complete set of tables showing you the DIP switch settings for the different types of application, as well as the default, or shipped, settings, please see the "Setting the DIP Switches for Your Application" section later in this chapter. These

tables are accompanied by descriptions of each type of setting and explanations of their effect.

Also with this model, the module's output is no longer limited to a 20 Vdc power source. The output is a 1 Amp, switched transistor output that you can drive from the station battery using 250, 125 or 48 Vdc. This means that you no longer need the auxiliary power supply (1610C07GXX), unless you are interfacing with a 20V based relay system, such as Uniflex or SKDU/SKBU, or most phase comparison relaying systems.

15.1.1 How It Works

During operation, the Receiver Logic Module takes the incoming signal from the Universal Receiver Module and, after determining the proper response, generates the appropriate guard and trip outputs. The module provides both the 1A, optically isolated, transistor switched (solid state) output for microprocessor based relays and, for electro-mechanical relay systems requiring contact outputs, a signal to the EM (Electro-Mechanical) Output Module.

The possible inputs the module receives from the Universal Receiver Module include the high frequency, center frequency, and low frequency

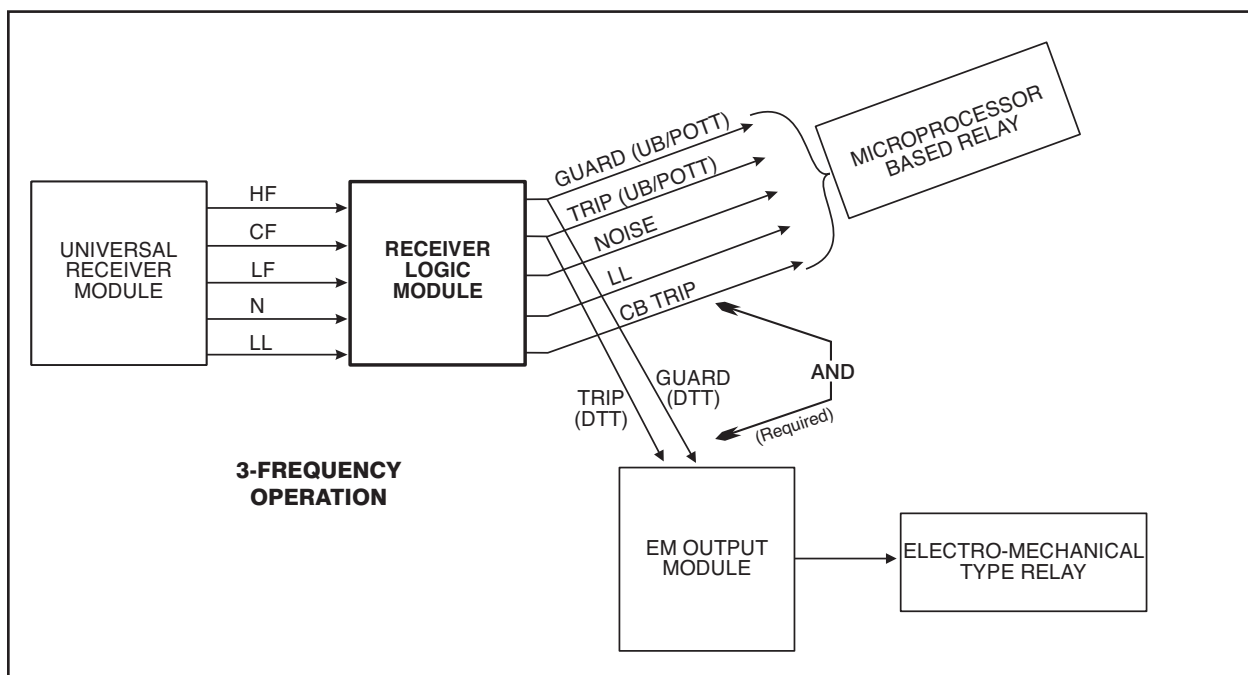

Figure 15-2. Simplified Signal Flow Diagram for 3-Frequency Operation.

signals, as well as (line) noise and low level signals.

The specific outputs the Receiver Logic Module generates are determined by the type of application (see “Receiver Logic Output Signals” below), the conditions of the input signal, and the settings of the module’s DIP switches.

15.1.2 Upgrade Information

The version (CF20-RXLMN) of the Receiver Logic Module is pin for pin compatible with the previous version (1606C52G01). We have also kept all the functions of the previous version. This lets you take advantage of the added features and flexibility of the new version without having to reconfigure your system.

Upgrading to the newer version of the Receiver Logic Module is as easy as 1–2–3:

1. Remove your old Receiver Logic Module.
2. Verify that the DIP switch settings on the new module are set correctly for your application (see “Setting the DIP Switches for Your Application”).
3. Insert your new Receiver Logic Module.

15.1.3 Receiver Logic Output Signals

The module provides output signals for the following types of application:

- 2-Frequency Directional Comparison (CF20-RXLMN-004)
- 3-Frequency Directional Comparison (CF20-RXLMN-002)
- 2-Frequency Phase Comparison (CF20-RXLMN-003)

Functional block diagrams are shown for each of these applications in Figures 15-7 (2-Frequency Directional Comparison), 15-8 (3-Frequency Directional Comparison), and 15-9 (2-Frequency Phase Comparison). The diagrams include the logic, inputs, outputs, DIP switch settings, and external (TCF-10B rear panel) connections for each application.

2-Frequency Phase Comparison Outputs

All 2-Frequency Phase Comparison output signals are 1 A switched transistor (solid state). These four output signals are:

- Trip Positive
- Trip Negative
- !Low Level
- Noise

2-Frequency Directional Comparison Outputs

For 2-Frequency Directional Comparison applications, the module provides both 1 A switched transistor (solid state) and electro-mechanical output signals.

The five 1A, switched transistor (solid state) output signals are:

- UB/POTT/DTT (Trip 1)
- Guard
- !Low Signal 1
- Checkback Trip 1
- Noise

The two electro-mechanical output signals are:

- Trip 1
- Guard 1

3-Frequency Directional Comparison Outputs

For 3-Frequency Directional Comparison applications, the module provides both 1 A switched transistor (solid state) and electro-mechanical output signals.

The five 1 A switched transistor (solid state) output signals are:

- UB/POTT (Trip 2)
- Guard 2 (UB/POTT)
- !Low Signal
- Checkback Trip
- Noise

The two electro-mechanical output signals are:

- Trip 1 (DTT)/Trip 2 (UB/POTT)
- Guard 1 (DTT)

15.1.4 Receiver Logic Front Panels

The front panel front panel of the TCF-10B Receiver Logic Module comes in three variations, one for each of the three application types (2-Frequency Directional Comparison, 3-Frequency Directional Comparison, and 2-Frequency Phase Comparison). Your module comes with a front panel that fits your application.

2-F Directional Comparison Front Panel

The front panel for 2-Frequency Directional Comparison applications is shown in Figure 15-3. Its four LEDs provide the following signal indications:

GOOD CHANNEL (this green LED is lit to indicate an absence of noise and low level)

CHECKBACK TRIP (this red LED is lit to indicate a low frequency is received; this will be the only LED lit when a low frequency is received after a loss-of-channel without a guard return)

TRIP (this red LED is lit to indicate a low frequency is received, i.e., the frequency shifts low)

GUARD (this red LED is lit to indicate a high frequency is received, i.e., the frequency shifts high)

3-F Directional Comparison Front Panel

The front panel for 3-Frequency Directional Comparison applications is shown in Figure 15-4. Its five LEDs provide the following signal indications:

GOOD CHANNEL (this green LED is lit to indicate an absence of noise and low level)

CHECKBACK TRIP (this red LED is lit to indicate a low frequency or high frequency is received, depending on the position of SW3-6; this LED will be lit without its corresponding trip LED when the high or

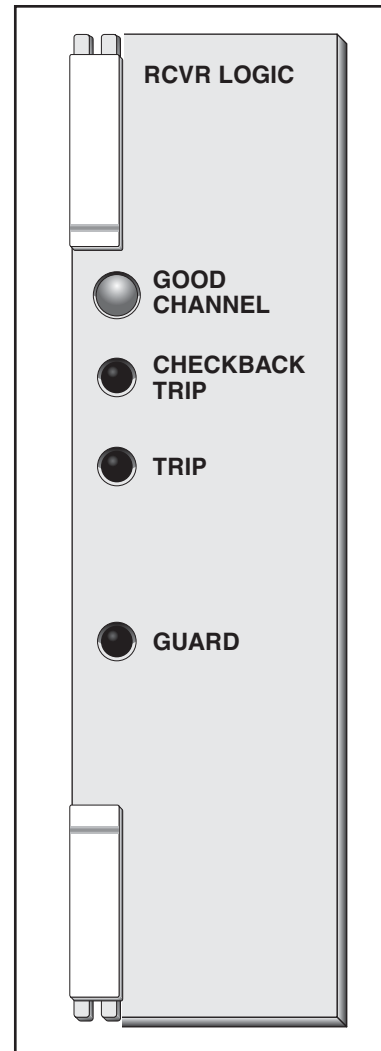

Figure 15-3.
Front Panel for 2-Frequency
Directional Comparison
(Transfer Trip/Unblock)
Applications.

low frequency is received following a loss-of-channel without a guard return))

UB/POTT TRIP (this red LED is lit to indicate a high frequency is received, i.e., the frequency shifts high)

DTT TRIP (this red LED is lit to indicate a low frequency is received, i.e., the frequency shifts low, indicating a direct transfer trip)

GUARD (this red LED is lit to indicate the center frequency is received, i.e., no frequency shift; the operation is normal)

2-F Phase Comparison Front Panel

The front panel for 2-Frequency Phase Comparison applications is shown in Figure 15-5. Its three LEDs provide the following signal indications:

GOOD CHANNEL (this green LED is lit to indicate an absence of noise and low level)

TRIP POSITIVE (this red LED and the Trip Negative LED alternately flash back and forth very rapidly — approx. 60 times a second each — to indicate normal operation of comparing phases)

TRIP NEGATIVE (this red LED and the Trip Positive LED alternately flash back and forth very rapidly — approx. 60 times a

NOTE:
SKBU/SPCU SYSTEM CONVENTION: (S1-2 in Normal)
Non-keyed state = High freq. (Trip Positive) Keyed state = Low Freq. (Negative)

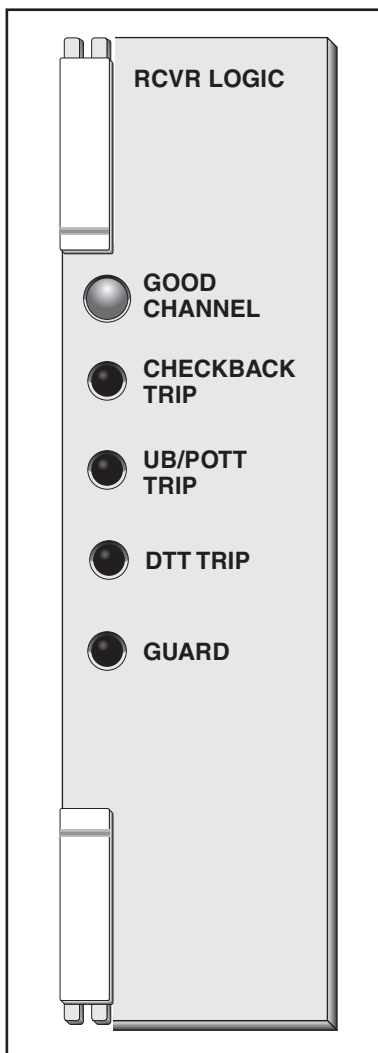

Figure 15-4.
Front Panel for 3-Frequency
Directional Comparison
(Transfer Trip/Unblock)
Applications.

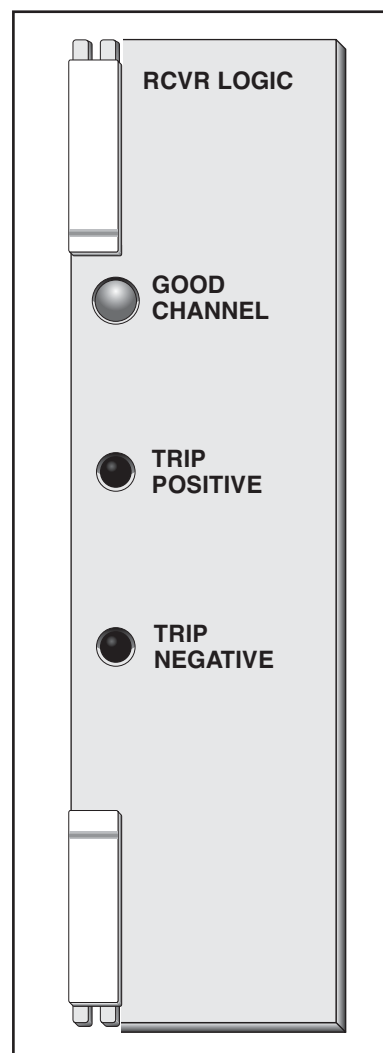

Figure 15-5.
Front Panel for 2-Frequency
Phase Comparison
Applications.

second each — to indicate normal operation of comparing phases)

15.1.5 Rear Panel Connections

Figure 15-6 shows the connection points for terminal block TB1 on the rear panel of your TCF-10B carrier set. It also shows the function of each position, or connection point. You make all your relay connections for both microprocessor based and electro-mechanical type relays to this terminal block.

For additional diagrams showing all the external (rear panel) connections for your TCF-10B, please refer to Figure 3-4 in Chapter 3 and Figure 6-1 in Chapter 6. For DIN connector pinouts for

each application, please see Figure 15-7 (2-F Directional Comparison).

15.2 Receiver Logic Signal Paths

The Receiver Logic Module has a different signal flow for each type of application. This is due primarily to the different plug-in EPLD chips used. The input signal (from the Universal Receiver Module) and your DIP switch settings also play a role. Figures 15-7, 15-8, and 15-9 provide functional block diagrams showing the logic and signal path for each application (2-F Directional Comparison, 3-F Directional Comparison, and 2-F Phase Comparison, respectively).

These three figures also show the logic states for the input from the Universal Receiver Module and (for the Directional Comparison applications) the output to the EM Output Module, the DIP switch settings, and the DIN connector pinouts — providing a comprehensive look at the module's signal flow.

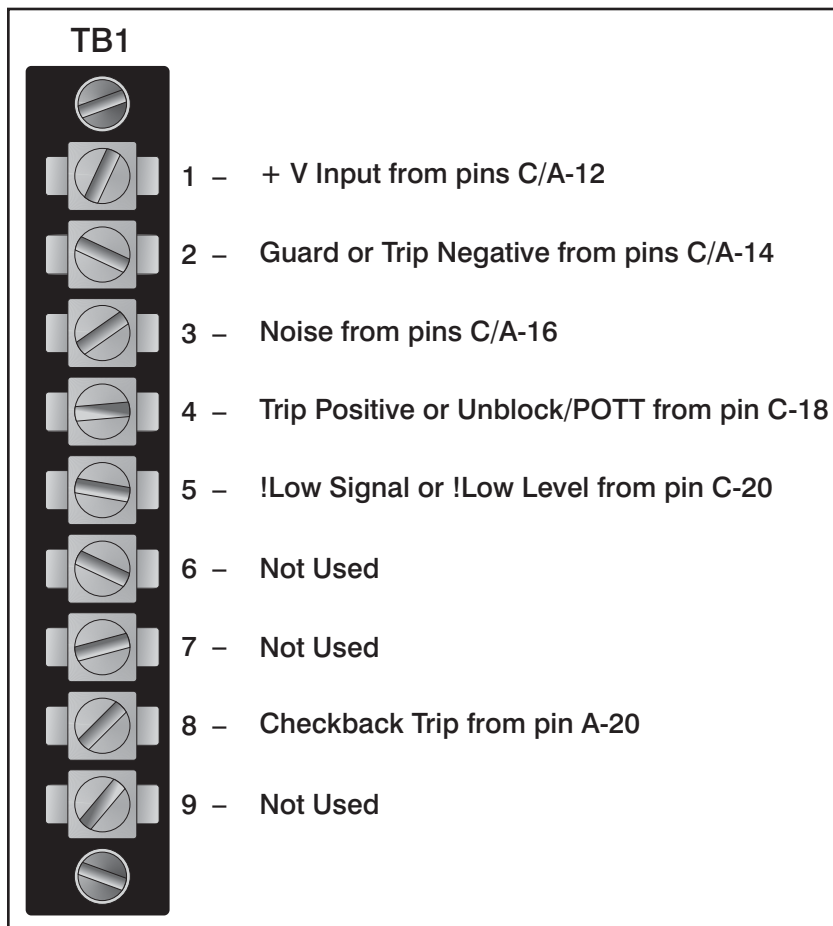

Figure 15-6. Receiver Logic External (Rear Panel) Connections.

Note: ! = inverted signal

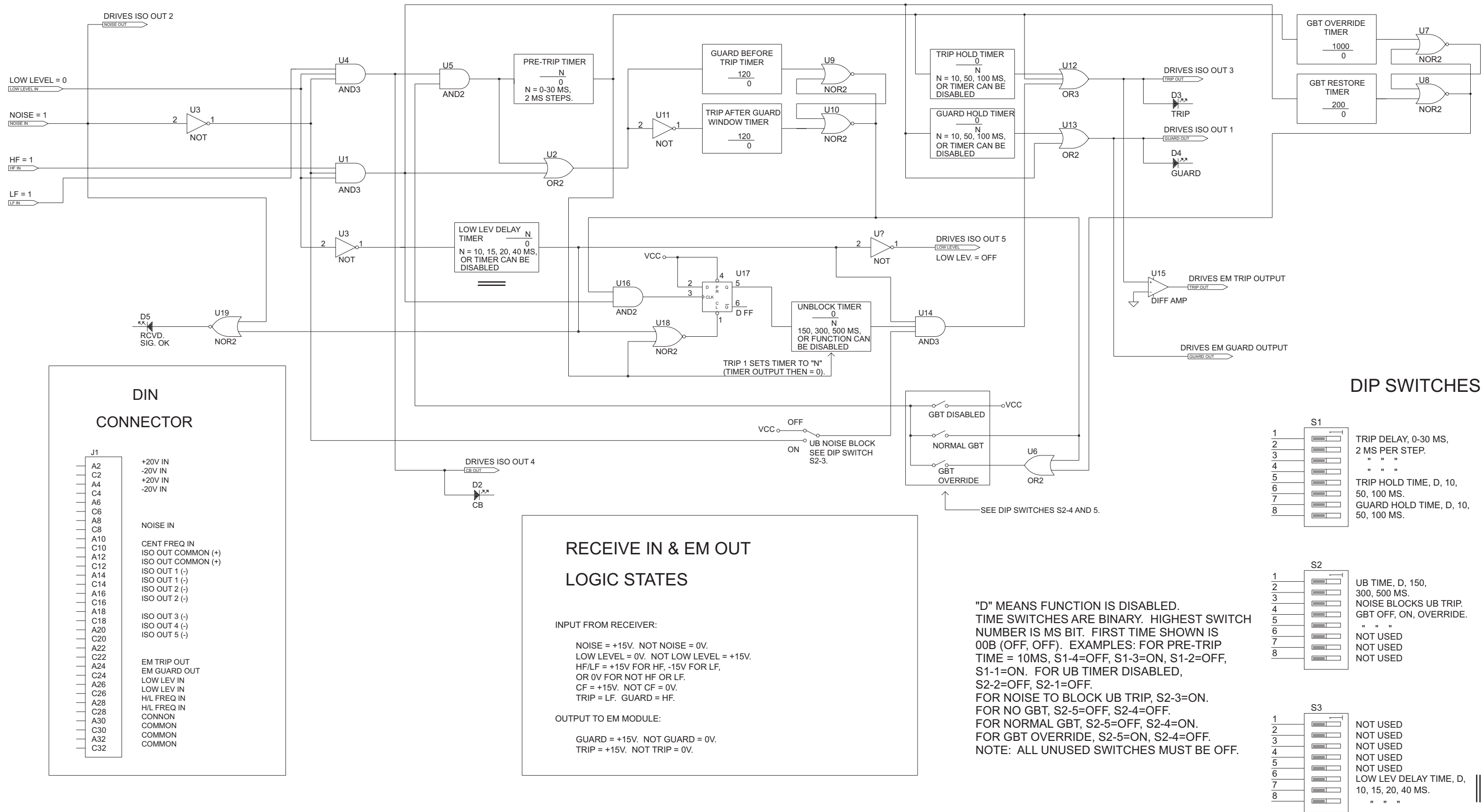
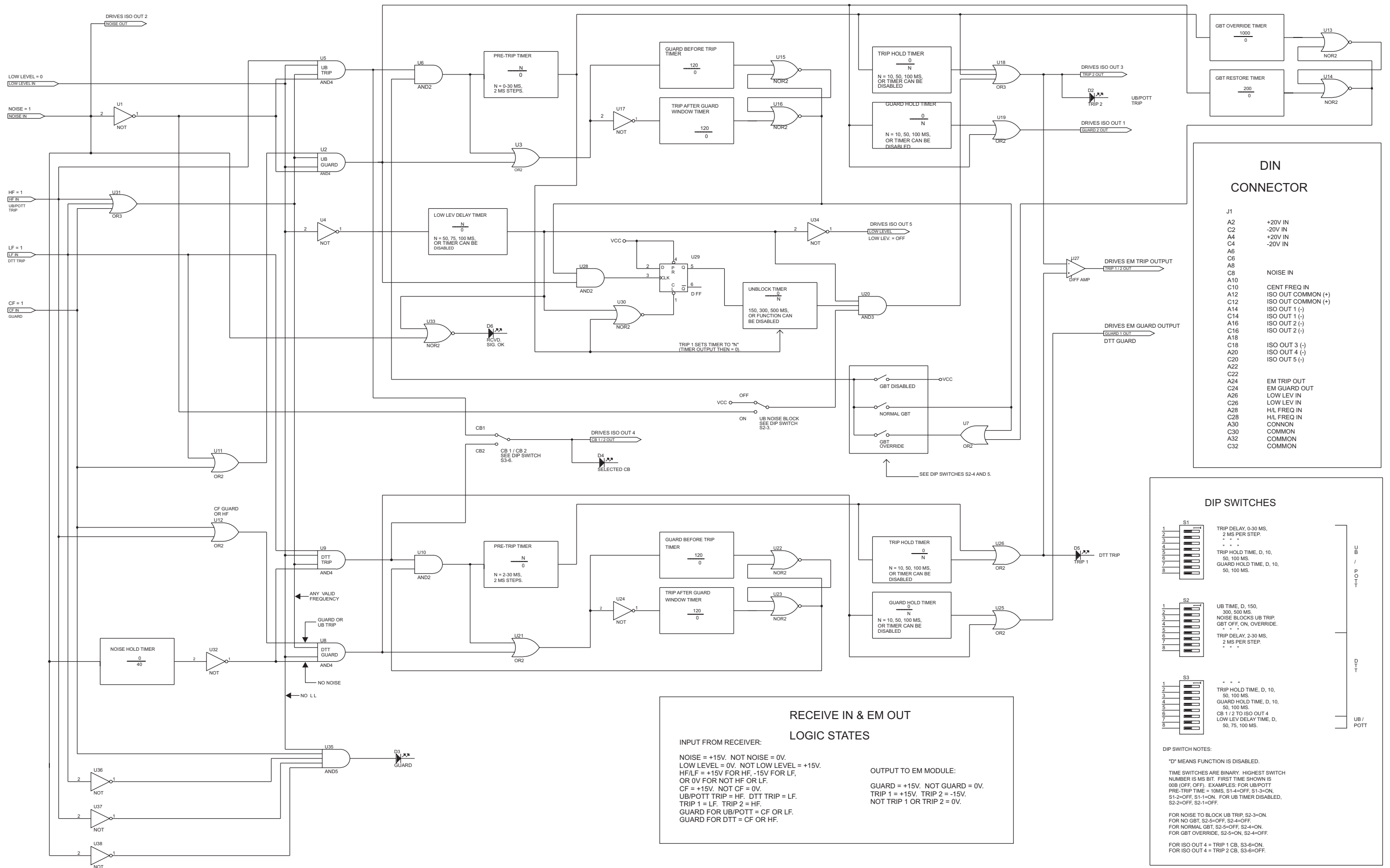
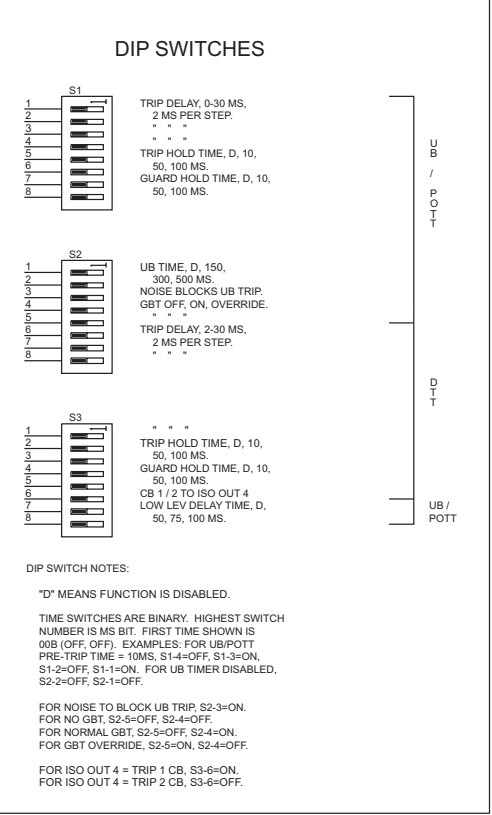

Figure 15-7. 2-Frequency Receive Logic Functional Block Diagram (CF44-VER06)



DIN CONNECTOR

J1	
A2	+20V IN
C2	-20V IN
A4	+20V IN
C4	-20V IN
A6	
C6	
A8	
C8	NOISE IN
A10	
C10	CENT FREQ IN
A12	ISO OUT COMMON (+)
C12	ISO OUT COMMON (+)
A14	ISO OUT 1 (-)
C14	ISO OUT 1 (-)
A16	ISO OUT 2 (-)
C16	ISO OUT 2 (-)
A18	
C18	ISO OUT 3 (-)
A20	ISO OUT 4 (-)
C20	ISO OUT 5 (-)
A22	
C22	
A24	EM TRIP OUT
C24	EM GUARD OUT
A26	LOW LEV IN
C26	LOW LEV IN
A28	H/L FREQ IN
C28	H/L FREQ IN
A30	COMMON
C30	COMMON
A32	COMMON
C32	COMMON



RECEIVE IN & EM OUT LOGIC STATES

INPUT FROM RECEIVER:

NOISE = +15V. NOT NOISE = 0V.
 LOW LEVEL = 0V. NOT LOW LEVEL = +15V.
 HF/LF = +15V FOR HF, -15V FOR LF,
 OR 0V FOR NOT HF OR LF.
 CF = +15V. NOT CF = 0V.
 UB/POTT TRIP = HF. DTT TRIP = LF.
 TRIP 1 = LF. TRIP 2 = HF.
 GUARD FOR UB/POTT = CF OR LF.
 GUARD FOR DTT = CF OR HF.

OUTPUT TO EM MODULE:

GUARD = +15V. NOT GUARD = 0V.
 TRIP 1 = +15V. TRIP 2 = -15V.
 NOT TRIP 1 OR TRIP 2 = 0V.

Figure 15-8. 3-Frequency Receive Logic Functional Block Diagram

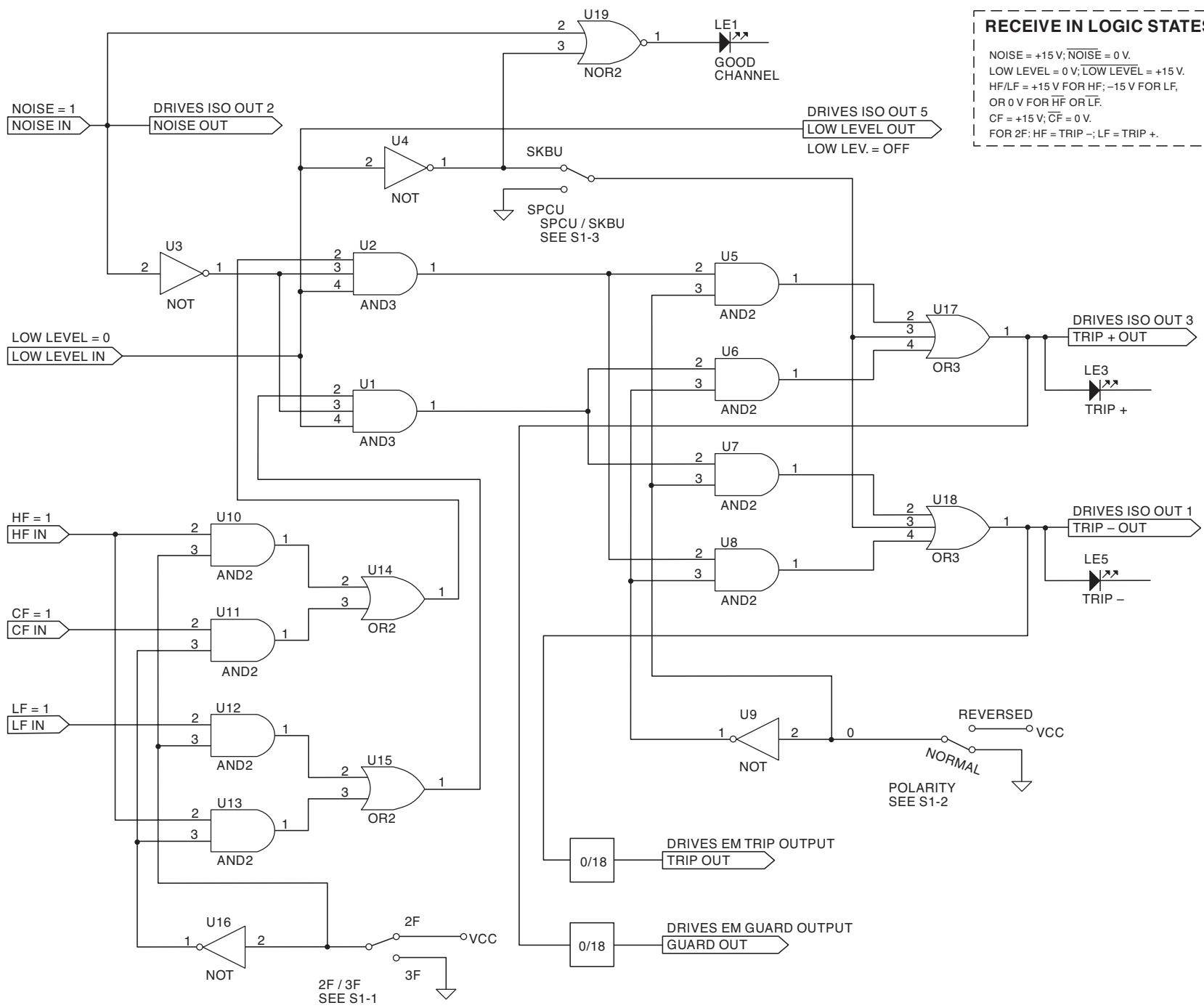

RECEIVE IN LOGIC STATES

NOISE = +15 V; NOISE = 0 V.
 LOW LEVEL = 0 V; LOW LEVEL = +15 V.
 HF/LF = +15 V FOR HF; -15 V FOR LF,
 OR 0 V FOR HF OR LF.
 CF = +15 V; CF = 0 V.
 FOR 2F: HF = TRIP -; LF = TRIP +.

DIP SWITCHES

S1

- 1 2F = OFF; 3F = ON
- 2 ON = NORMAL; OFF = REVERSED
- 3 SPCU = OFF; SKBU = ON
- 4 NOT USED
- 5 NOT USED
- 6 NOT USED
- 7 NOT USED
- 8 NOT USED

S2

- 1 NOT USED
- 2 NOT USED
- 3 NOT USED
- 4 NOT USED
- 5 NOT USED
- 6 NOT USED
- 7 NOT USED
- 8 NOT USED

S3

- 1 NOT USED
- 2 NOT USED
- 3 NOT USED
- 4 NOT USED
- 5 NOT USED
- 6 NOT USED
- 7 NOT USED
- 8 NOT USED

NOTE: ALL UNUSED SWITCHES MUST BE OFF.

DIN CONNECTOR

+20 V IN	A2
-20 V IN	C2
+20 V IN	A4
-20 V IN	C4
	A6
	C6
	A8
NOISE IN	C8
	A10
CENT FREQ IN	C10
ISO OUT COMMON (+)	A12
ISO OUT COMMON (+)	C12
ISO OUT 1 (-)	A14
ISO OUT 1 (-)	C14
ISO OUT 2 (-)	A16
ISO OUT 2 (-)	C16
	A18
ISO OUT 3 (-)	C18
ISO OUT 4 (-)	A20
ISO OUT 5 (-)	C20
	A22
	C22
EM TRIP OUT	A24
EM GUARD OUT	C24
LOW LEV IN	A26
LOW LEV IN	C26
H/L FREQ IN	A28
H/L FREQ IN	C28
COMMON	A30
COMMON	C30
COMMON	A32
COMMON	C32

Figure 15-9. Phase Comparison Functional Block Diagram.

15.3 Receiver Logic

2-Frequency Directional Comparison Logic

This logic can be configured for a typical Direct Transfer Trip or Directional Comparison Unblock System.

To provide the utmost security, this logic provides for 120ms of guard before trip logic. It requires that after loss of signal, there must be at least 120ms of guard before the system is allowed to trip. This may be disabled or overridden according to system requirements. Details follow.

There is also a 120ms trip after guard requirement that requires within 120ms of losing guard, trip is received, otherwise the channel locks out from tripping.

Hold timers are available for both the trip and guard outputs that can be selected for 10, 50 or 100ms or be disabled. These timers are on the output side of the logic and therefore only affect the solid state or electromechanical outputs. They have no affect on the functionality of the internal logic.

The pre-trip timer allows for higher security by delaying the trip output by the time set. Unblock functions will typically be 0ms but DTT functions will typically be on the order of 20 or 30ms.

The logic also provides for line protection of the transmission line when the remote end's breaker is open. Upon receiving a trip signal from the other end for longer than 1000ms, indicating an open breaker, the logic disables the guard before trip requirement such that if the channel is lost and returns in the trip state, the line relay system will be allowed to trip for a fault. To allow for this scenario, the guard before trip should be set for "override". After guard is restored, the logic is reset after 200ms. Typical line relaying or DTT systems do not disable guard before trip logic.

Unblock logic is provided in the TCF-10B to force a trip on loss of channel. If a fault causes a loss of channel there is a window selectable between 150, 300 or 500ms that will produce a trip output. After this time, the channel is locked out from tripping until it receives 120ms of guard. The assertion of

the trip output for unblock can be delayed by 10, 15, 20 or 40 ms if desired. Typical permissive overreaching transfer trip systems used over Power Line Carrier take advantage of the Unblock Logic and are called Directional Comparison Unblock systems.

A checkback trip output is provided for testing purposes. The checkback trip will always assert anytime a trip is asserted by the logic. However if a trip frequency is received after a loss of channel (without guard return), then only a checkback trip is asserted.

15.4 3-Frequency Directional Comparison Logic

This logic is similar to the 2-frequency logic except with the addition of logic to handle the Direct Transfer Trip logic separately, in addition to providing for a Directional Comparison Unblock System.

The Guard Before Trip and Trip After Guard is duplicated for the DTT portion as well as the Trip hold and Guard hold timers.

The outputs available for the Unblock portion of the logic are the 1A transistor switch outputs (TB-1) as noted in section 15.1.3 The outputs available for the DTT portion of the logic are only available from the E/M Output module (TB5&6) shown in Chapter 16. Additionally either the trip1 (DTT)/trip2(Unblock) signal or the guard 1 signal drives the electromechanical outputs. To assert an e/m relay with the DTT trip (Trip 1), the input is driven by a +15V signal. To assert it with the Unblock trip (trip 2), the input is driven by a -15V signal. The Guard 1 signal that is applied to the e/m relay card is the DTT guard signal. To monitor the Unblock guard signal, use the 1A transistor switch output from the logic card itself.

Note that when the 3-frequency system goes to an Unblock trip, the Guard 1 (DTT) does not drop out but the Guard 2 (Unblock) does. Likewise on a DTT Trip the Guard 2 does not dropout but the Guard 1 does. Further explanation of the timer settings are explained in section 15.5.

15.5 Setting the DIP Switches for Your Application

As noted earlier, the Receiver Logic Module uses a plug-in EPLD chip to control its logic functions. Your Receiver Logic Module comes to you with the EPLD chip for your type of application already installed. The only adjustments you need to consider are the module's DIP switch settings. Following are three sets of tables showing you all the DIP switch settings that apply to each type of application. The tables also show you the default, or shipped, setting for each switch. These are the most secure settings for your application. Accompanying each table is a description of that switch setting and an explanation of its effect.

15.5.1 Switch Settings for 2-Frequency Directional Comparison (POTT/DTT/UB) Applications

Pre-Trip Timer (POTT/DTT/UB 2F)

The Pre-Trip Timer does not allow tripping until the trip signal has been present for the time you set. You can set this timer from 0 to 30ms in 2ms increments. A typical application of this timer in Direct Transfer Trip systems is to set it for the maximum delay possible. Limitations on the critical clearing time of the

Table 15–2. Trip Delay Switch Settings for POTT/DTT/UB 2F Applications.

TIME IN ms	SW1-1	SW1-2	SW1-3	SW1-4
0	OPEN	OPEN	OPEN	OPEN
2	CLOSED	OPEN	OPEN	OPEN
4	OPEN	CLOSED	OPEN	OPEN
6	CLOSED	CLOSED	OPEN	OPEN
8	OPEN	OPEN	CLOSED	OPEN
10	CLOSED	OPEN	CLOSED	OPEN
12	OPEN	CLOSED	CLOSED	OPEN
14	CLOSED	CLOSED	CLOSED	OPEN
16	OPEN	OPEN	OPEN	CLOSED
18	CLOSED	OPEN	OPEN	CLOSED
20	OPEN	CLOSED	OPEN	CLOSED
22	CLOSED	CLOSED	OPEN	CLOSED
24	OPEN	OPEN	CLOSED	CLOSED
26	CLOSED	OPEN	CLOSED	CLOSED
28	OPEN	CLOSED	CLOSED	CLOSED
30	CLOSED	CLOSED	CLOSED	CLOSED

power system will have a direct impact on this setting. In Directional Unblock/POTT systems, you set this timer for 0ms.

The trip delay time switch settings are listed in Table 15-2.

← Position when shipped

**Trip Hold Timer
(POTT/DTT/UB 2F)**

The Trip Hold Timer lets you stretch the trip output. You can set it for 10, 50, or 100ms or disable (0ms) it. We recommend that you use the disabled setting in the Unblock/POTT to avoid problems with transient blocking.

The trip hold time switch settings are listed in Table 15-3.

Table 15-3. Trip Hold Time Switch Settings for POTT/DTT/UB 2F Applications.

TIME IN ms	SW1-5	SW1-6
DISABLED	OPEN	OPEN
10	CLOSED	OPEN
50	OPEN	CLOSED
100	CLOSED	CLOSED

**Guard Hold Timer
(POTT/DTT/UB 2F)**

The Guard Hold Timer stretches the guard output by the amount you set. You can set it for 10, 50, or 100ms or disable (0ms) it. The disabled setting is appropriate for most applications.

The guard hold time switch settings are listed in Table 15-4.

Table 15-4. Guard Hold Time Switch Settings for POTT/DTT/UB 2F Applications.

TIME IN ms	SW1-7	SW1-8
DISABLED	OPEN	OPEN
10	CLOSED	OPEN
50	OPEN	CLOSED
100	CLOSED	CLOSED

Position when shipped

**Unblock Timer
(POTT/DTT/UB 2F)**

The Unblock Timer provides a trip output for the time set on loss of channel, which is defined as low level and loss of guard. You can set it for 150, 300, or 500ms. The normal setting is 150ms in the Unblock system and disabled for all other applications. This is what differentiates the Unblock system from the POTT.

The unblock time switch settings are listed in Table 15-5.

Table 15-5. Unblock Time Switch Settings for POTT/DTT/UB 2F Applications.

TIME IN ms	SW2-1	SW2-2
DISABLED	OPEN	OPEN
150	CLOSED	OPEN
300	OPEN	CLOSED
500	CLOSED	CLOSED

**Noise Block of Unblock
(POTT/DTT/UB 2F)**

With this switch (SW2-3) closed, noise will disable the Unblock trip output. Normal application is with this switch opened.

The noise block of unblock switch settings are listed in Table 15-6.

Table 15–6. Noise Block of Unblock Switch Settings for POTT/DTT/UB 2F Applications.

FUNCTION	SW2-3
NOISE ALLOWS UB TRIP	OPEN
NOISE BLOCKS UB TRIP	CLOSED

**Guard before Trip
(POTT/DTT/UB 2F)**

With this function set to “on without override”, the logic requires guard to be received for 120 ms before the system is allowed to trip. With it set to “on with override”, the 120 ms guard return is required except where trip has been received for over 1,000 ms; if there is a loss of channel, then the guard is not required prior to tripping. Typically, you would use this where open breaker keying is required.

The guard before trip time switch settings are listed in Table 15-7.

Table 15–7. Guard Before Trip Switch Settings for POTT/DTT/UB 2F Applications.

FUNCTION	SW2-4	SW2-5
OFF	OPEN	OPEN
ON W/O OVER	CLOSED	OPEN
ON W OVER	OPEN	CLOSED
NOT USED	CLOSED	CLOSED

Position when shipped

**Low Level Delay Timer
(POTT/DTT/UB 2F)**

The Low Level Delay Timer delays the Unblock timer from initiating a trip output on loss of channel; it also delays the low level output. You can set it for 10, 15, 20 or 40 ms or disable (0 ms) it.

The low level delay time switch settings are listed in Table 15-8.

Table 15–8. Low Level Delay Switch Settings for POTT/DTT/UB 2F Applications.

TIME IN ms	SW3-6	SW3-7	SW3-8
DISABLED	OPEN	OPEN	OPEN
10	CLOSED	OPEN	OPEN
15	OPEN	CLOSED	OPEN
20	CLOSED	CLOSED	OPEN
40	OPEN	OPEN	CLOSED

These time selections are only available on the RCVR LOGIC-A module (CF20-RXLMN-004).

NOTE:
SW2-6 through SW2-8 and SW3-1 through SW3-5 are not used in the 2-Frequency Directional Comparison logic program.

15.5.2 Switch Settings for POTT/UB Portion 3F Applications

Pre-Trip Timer (POTT/UB 3F)

The Pre-Trip Timer does not allow tripping until the trip signal has been present for the time you set. You can set this timer from 0 (disabled) to 30ms in 2ms increments. A typical application of this timer in Direct Transfer Trip systems is to set it for the maximum delay possible. Limitations on the critical clearing time of the power system will have a direct impact on this setting. In Directional Comparison Unblock/POTT systems, you set this timer for 0ms.

The trip delay time switch settings are listed in Table 15-9.

Table 15-9. Trip Delay Switch Settings for POTT/UB 3F Applications.

TIME IN ms	SW1-1	SW1-2	SW1-3	SW1-4
0	OPEN	OPEN	OPEN	OPEN
2	CLOSED	OPEN	OPEN	OPEN
4	OPEN	CLOSED	OPEN	OPEN
6	CLOSED	CLOSED	OPEN	OPEN
8	OPEN	OPEN	CLOSED	OPEN
10	CLOSED	OPEN	CLOSED	OPEN
12	OPEN	CLOSED	CLOSED	OPEN
14	CLOSED	CLOSED	CLOSED	OPEN
16	OPEN	OPEN	OPEN	CLOSED
18	CLOSED	OPEN	OPEN	CLOSED
20	OPEN	CLOSED	OPEN	CLOSED
22	CLOSED	CLOSED	OPEN	CLOSED
24	OPEN	OPEN	CLOSED	CLOSED
26	CLOSED	OPEN	CLOSED	CLOSED
28	OPEN	CLOSED	CLOSED	CLOSED
30	CLOSED	CLOSED	CLOSED	CLOSED

← Position
when
shipped

Trip Hold Timer (POTT/UB 3F)

The Trip Hold Timer lets you stretch the trip output. You can set it for 10, 50, or 100ms or disable (0ms) it. We recommend that you use the disabled setting in the Unblock/POTT to avoid problems with transient blocking.

The trip hold time switch settings for 3-frequency UB/POTT applications are listed in Table 15-10. The trip hold time switch settings for 3-frequency DTT applications are listed in Table 15-17.

Table 15–10. Trip Hold Time Switch Settings for POTT/UB 3F Applications.

TIME IN ms	SW1-5	SW1-6
DISABLED	OPEN	OPEN
10	CLOSED	OPEN
50	OPEN	CLOSED
100	CLOSED	CLOSED

Guard Hold Timer (POTT/UB 3F)

The Guard Hold Timer stretches the guard output by the amount you set. You can set it for 10, 50, or 100ms or disable (0ms) it. The disabled setting is appropriate for most applications.

The guard hold time switch settings for 3-frequency UB/POTT applications are listed in Table 15-11. The guard hold time switch settings for 3-frequency DTT applications are listed in Table 15-18.

Table 15–11. Guard Hold Time Switch Settings for POTT/UB 3F Applications.

TIME IN ms	SW1-7	SW1-8
DISABLED	OPEN	OPEN
10	CLOSED	OPEN
50	OPEN	CLOSED
100	CLOSED	CLOSED

Position when shipped

Unblock Timer (POTT/UB 3F)

The Unblock Timer provides a trip output for the time set on loss of channel, which is defined as low level and loss of guard. You can set it for 150, 300, or 500ms. The normal setting is 150ms in the Unblock system and disabled for all other applications. This timer is what differentiates the Unblock system from the POTT.

The unblock time switch settings are listed in Table 15-12.

Table 15–12. Unblock Time Switch Settings for POTT/UB 3F Applications.

TIME IN ms	SW2-1	SW2-2
DISABLED	OPEN	OPEN
150	CLOSED	OPEN
300	OPEN	CLOSED
500	CLOSED	CLOSED

Noise Block of Unblock (POTT/UB 3F)

With this switch (SW2-3) closed, noise will disable the Unblock trip output. Normal application is with this switch opened.

The noise block of unblock switch settings are listed in Table 15-13.

Table 15-13. Noise Block of Unblock Switch Settings for POTT/UB 3F Applications.

FUNCTION	SW2-3
NOISE ALLOWS UB TRIP	OPEN
NOISE BLOCKS UB TRIP	CLOSED

Guard before Trip (POTT/UB 3F)

With this function set to “on without override”, the logic requires guard to be received for 120ms before the system is allowed to trip. With it set to “on with override”, the 120ms guard return is required except where trip has been received for over 1,000ms; if there is a loss of channel, then the guard is not required prior to tripping. Typically, you would use this where open breaker keying is required.

The guard before trip time switch settings are listed in Table 15-14.

Table 15-14. Guard Before Trip Switch Settings for POTT/UB 3F Applications.

TIME IN ms	SW2-4	SW2-5
OFF	OPEN	OPEN
ON W/O OVER	CLOSED	OPEN
ON W OVER	OPEN	CLOSED
NOT USED	CLOSED	CLOSED

Position when shipped

Low Level Delay Timer (POTT/UB 3F)

The Low Level Delay Timer delays the Unblock timer from initiating a trip output on loss of channel; it also delays the low level output. You can set it for 50, 75, or 100ms or disable (0ms) it.

The low level delay time switch settings are listed in Table 15-15.

Table 15-15. Low Level Delay Switch Settings for POTT/UB 3F Applications.

TIME IN ms	SW3-7	SW3-8
DISABLED	OPEN	OPEN
50	CLOSED	OPEN
75	OPEN	CLOSED
100	CLOSED	CLOSED

NOTE:
 Your Receiver Logic Module is shipped to you with SW3-6 set to the CLOSED position. This is currently the only active setting for this switch, so be sure to leave it in the CLOSED position.

15.5.3 Switch Settings for DTT Portion of 3F Applications

Pre-Trip Timer (DTT 3F)

The Pre-Trip Timer does not allow tripping until the trip signal has been present for the time you set. You can set this timer from 2 to 30ms in 2ms increments. A typical application of this timer in Direct Transfer Trip systems is to set it for the maximum delay possible. Limitations on the critical clearing time of the power system will have a direct impact on this setting.

The trip delay time switch settings are listed in Table 15-16.

Table 15–16. Trip Delay Switch Settings for DTT 3F Applications.

TIME IN ms	SW2-6	SW2-7	SW2-8	SW3-1
2	OPEN	OPEN	OPEN	OPEN
2	CLOSED	OPEN	OPEN	OPEN
4	OPEN	CLOSED	OPEN	OPEN
6	CLOSED	CLOSED	OPEN	OPEN
8	OPEN	OPEN	CLOSED	OPEN
10	CLOSED	OPEN	CLOSED	OPEN
12	OPEN	CLOSED	CLOSED	OPEN
14	CLOSED	CLOSED	CLOSED	OPEN
16	OPEN	OPEN	OPEN	CLOSED
18	CLOSED	OPEN	OPEN	CLOSED
20	OPEN	CLOSED	OPEN	CLOSED
22	CLOSED	CLOSED	OPEN	CLOSED
24	OPEN	OPEN	CLOSED	CLOSED
26	CLOSED	OPEN	CLOSED	CLOSED
28	OPEN	CLOSED	CLOSED	CLOSED
30	CLOSED	CLOSED	CLOSED	CLOSED

← Position when shipped

Trip Hold Timer (DTT 3F)

The Trip Hold Timer lets you stretch the trip output. You can set it for 10, 50, or 100ms or disable (0ms) it.

The trip hold time switch settings are listed in Table 15-17.

Table 15-17. Trip Hold Time Switch Settings for DTT 3F Applications.

TIME IN ms	SW3-2	SW3-3
DISABLED	OPEN	OPEN
10	CLOSED	OPEN
50	OPEN	CLOSED
100	CLOSED	CLOSED

Position when shipped

Guard Hold Timer (DTT 3F)

The Guard Hold Timer stretches the guard output by the amount you set. You can set it for 10, 50, or 100ms or disable (0ms) it. The disabled setting is appropriate for most applications.

The guard hold time switch settings are listed in Table 15-18.

Table 15-18. Guard Hold Time Switch Settings for DTT 3F Applications.

TIME IN ms	SW3-4	SW3-5
DISABLED	OPEN	OPEN
10	CLOSED	OPEN
50	OPEN	CLOSED
100	CLOSED	CLOSED

Checkback Trip Output

Checkback trip is available for either the Unblock Application (CB1) or the DTT Application (CB2). Set SW3-6 for the appropriate setting. The Checkback trip output settings are listed in Table 15-19.

Table 15-19. Checkback Trip Output Settings.

CB Trip	SW3-6
CB1	OPEN
CB2	CLOSED

15.5.4 Switch Settings for Phase Comparison 2F Applications

Polarity

This switch lets you define the high frequency as trip positive and the low frequency as trip negative. The “NORMAL” setting sets the high frequency as trip negative and the low frequency as trip positive.

The polarity switch settings are listed in Table 15-20.

Table 15–20.
Polarity Switch Settings for
Phase Comparison Applications.

POLARITY	SW1-2
NORMAL	CLOSED
REVERSED	OPEN

Position
when
shipped

SPCU/SKBU

This switch lets you define what the logic does for a low level. In the SPCU, a low level or noise clamps trip positive and trip negative to a logical zero. In SKBU, a low level clamps trip positive and trip negative to a logical one.

The SPCU/SKBU switch settings are listed in Table 15-21.

Table 15–21.
SPCU/SKBU Switch Settings for
Phase Comparison Applications.

PHASE COMPARISON TYPE	SW1-3
SPCU/REL350	OPEN
SKBU/REL352	CLOSED

NOTE:

Your Receiver Logic Module is shipped to you with SW1-1 set to the OPEN position. This is currently the only active setting for this switch, so be sure to leave it in the OPEN position. SW1-4 through SW1-8, SW2-1 through SW2-8 and SW3-1 through SW3-8 are not used in the 2-Frequency Phase Comparison logic programs.

15.6 Troubleshooting

You can use your normal troubleshooting techniques to isolate and check faulty components.

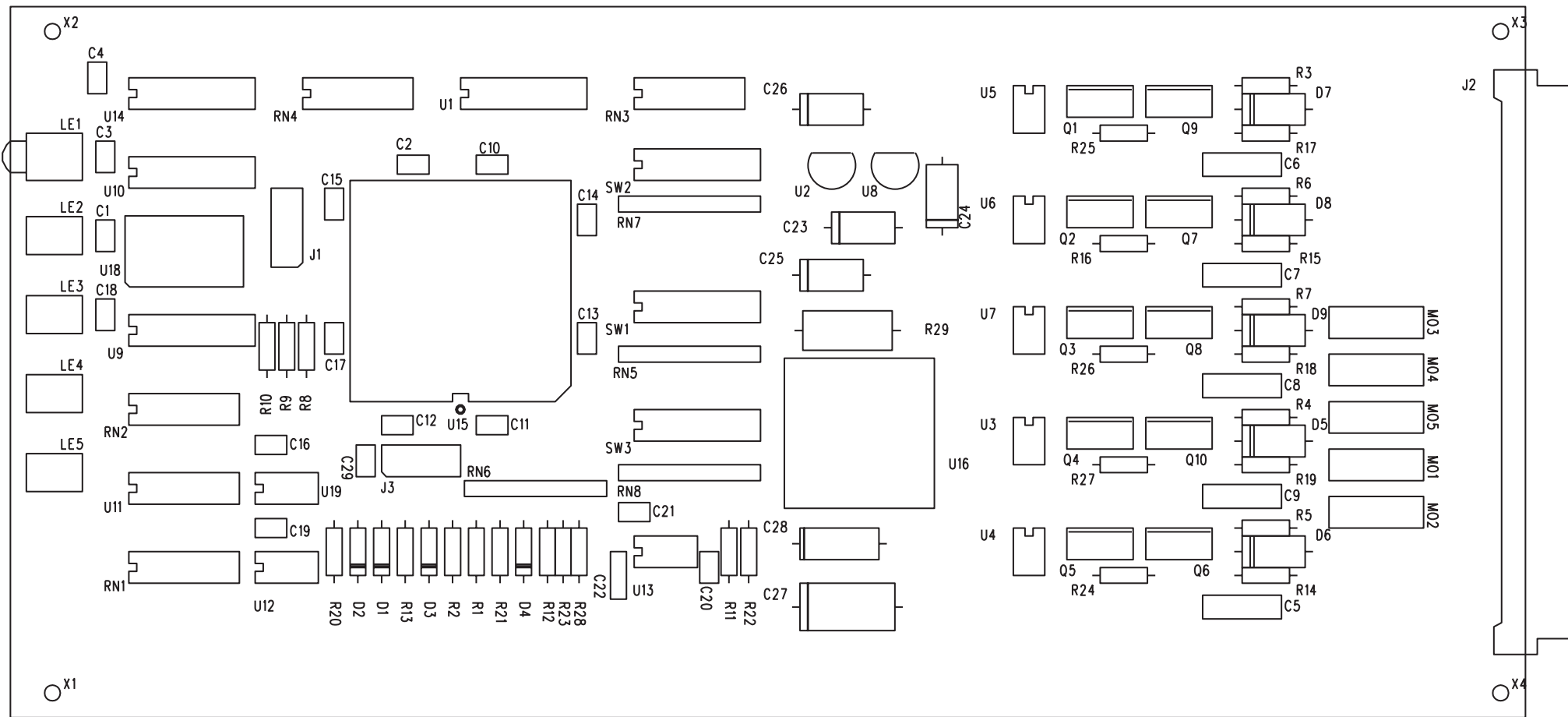
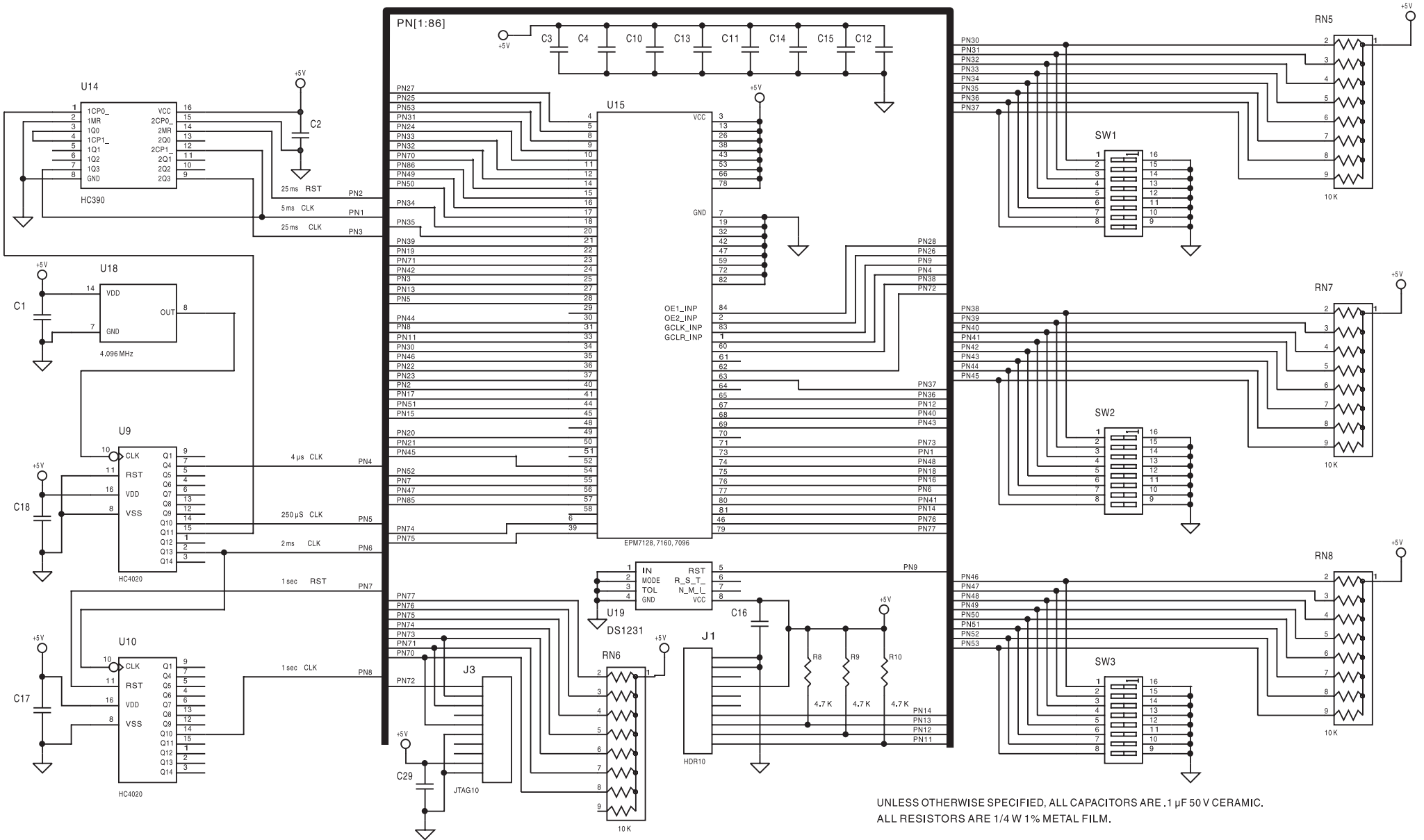

Figure 15-10. TCF-10B Receiver Logic Component Location. (CF50RXLM)

Figure 15-11 TCF-10B Receiver Logic Schematic (Sheet 1 of 3).



UNLESS OTHERWISE SPECIFIED, ALL CAPACITORS ARE .1 μF 50 V CERAMIC.
 ALL RESISTORS ARE 1/4 W 1% METAL FILM.

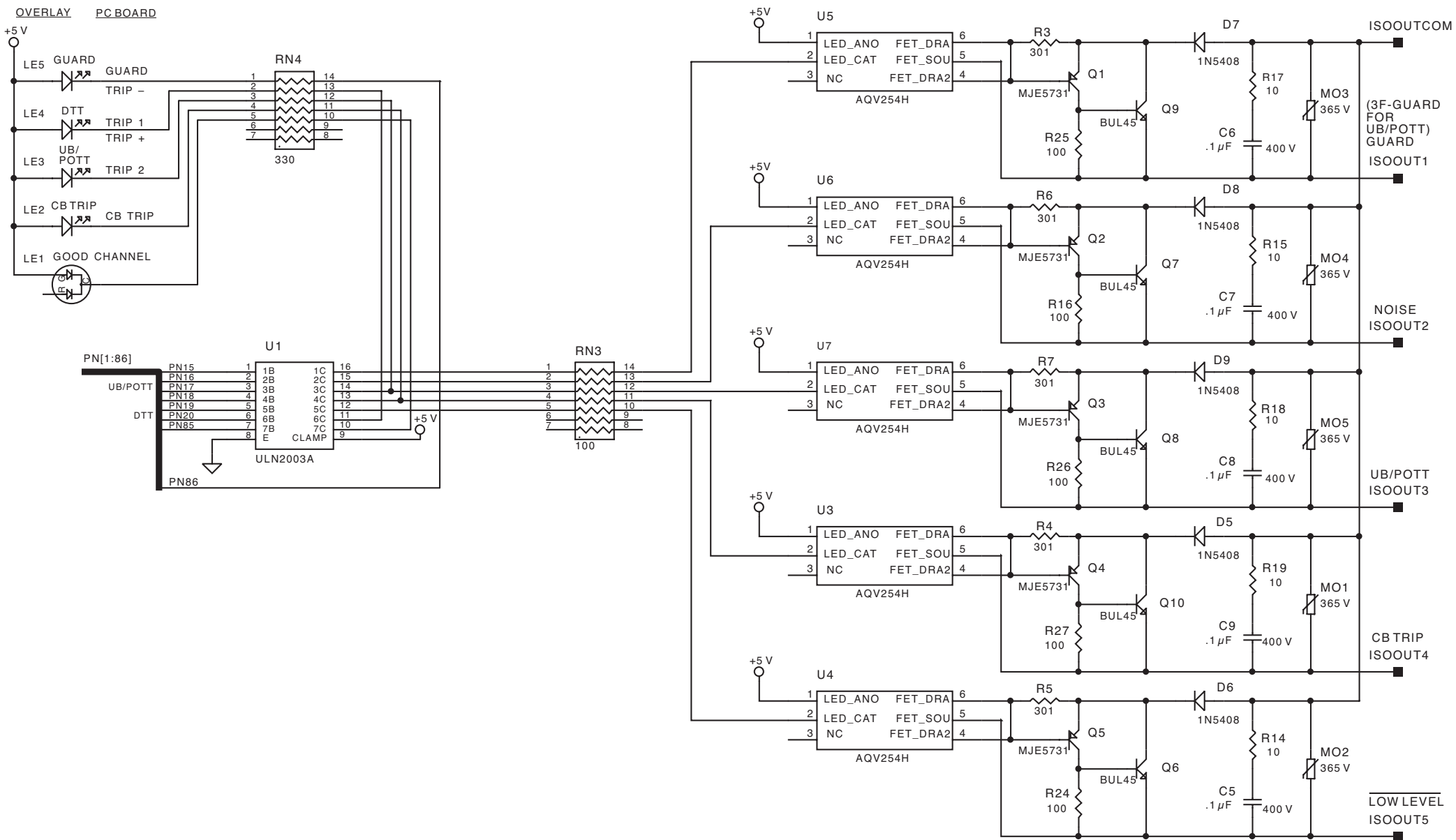
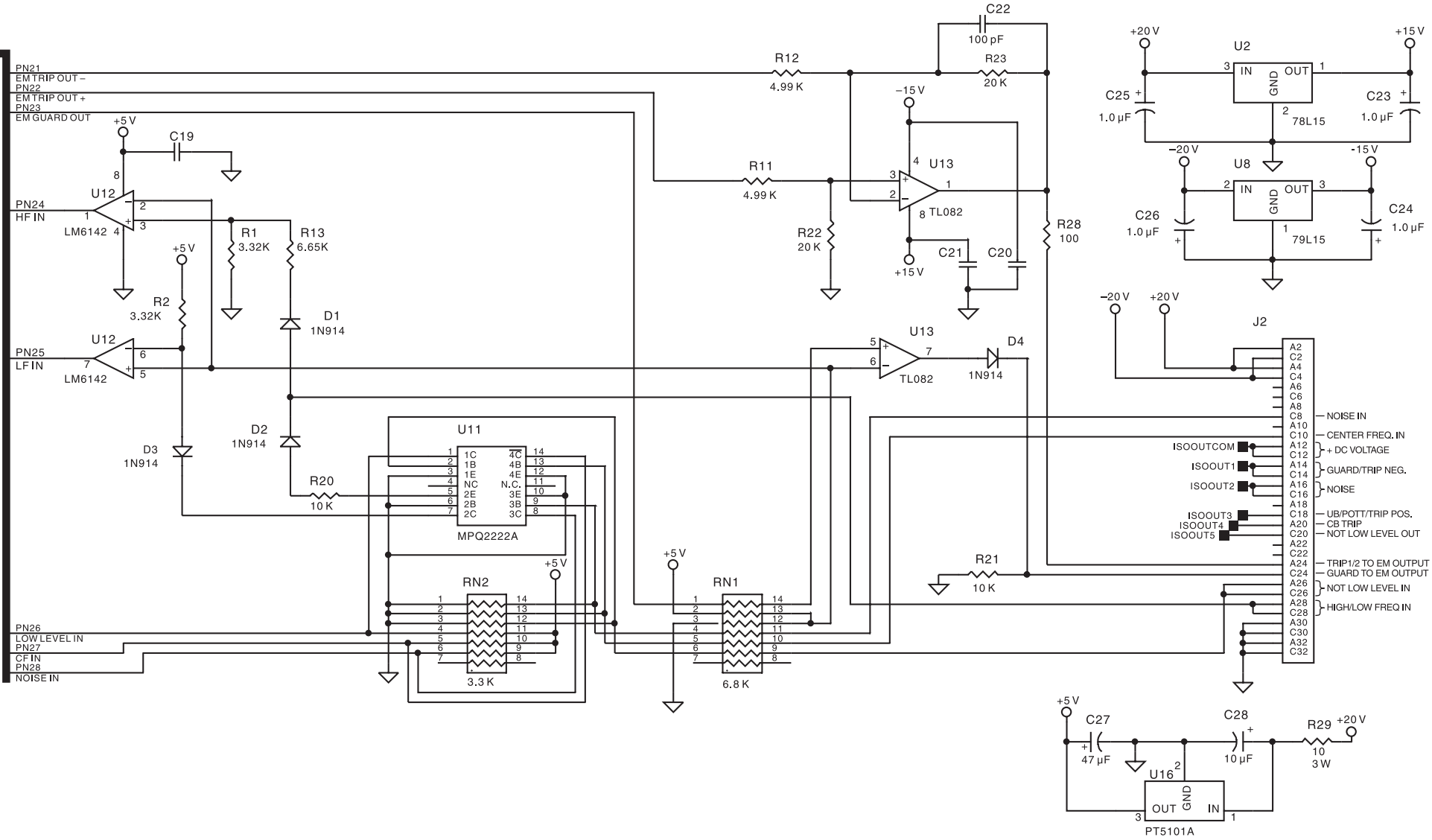

Figure 15-12 TCF-10B Receiver Logic Schematic (Sheet 2 of 3).

Figure 15-13 TCF-10B Receiver Logic Schematic (Sheet 3 of 3).

PN[1:53]



Chapter 16. Optional Electro-Mechanical (EM) Output Module

Table 16–1. 1606C53 Styles and Descriptions.

Schematic	1606C53-7
-----------	-----------

Group	Description
G01	Without Trip extension
G02	With Trip extension

16.1 EM Output Module Description

This module provides six (6) contact sets, for the TCF–10B, for Trip or Guard output, as follows:

Table 16–2. Output Options.

Board Label	2F Functions	3F Functions
Trip 1	DTT/POTT/UB	DTT Trip
Trip 2	–	UB/POTT TRIP
Guard	Guard	DTT Guard*

* only available on EM Output TB

K5 JU5, JU11, D13, D15, Q5, Q11

K6 JU6, JU12, D16, D18, Q6, Q12

Jumpers JU13 and JU14 provide selectable “Trip Delays” for Trip 1 and Trip 2.

16.1.1 EM Output Front Panel

The front panel is without operator controls as shown in Figure 16-1.

16.1.2 EM Output PC Board

(The EM Output PC Board is shown in Figure 16-2.)

Jumpers JU1 through JU6 are used to select Trip 1, Trip 2, or Guard signals. Jumpers JU7 through JU12 set the output relay contacts at either the NO or NC position. The following jumpers and associated components work with each of the six relays:

- K1 JU1, JU7, D1, D3, Q1, Q7
- K2 JU2, JU8, D4, D6, Q2, Q8
- K3 JU3, JU9, D7, D9, Q3, Q9
- K4 JU4, JU10, D10, D12, Q4, Q10

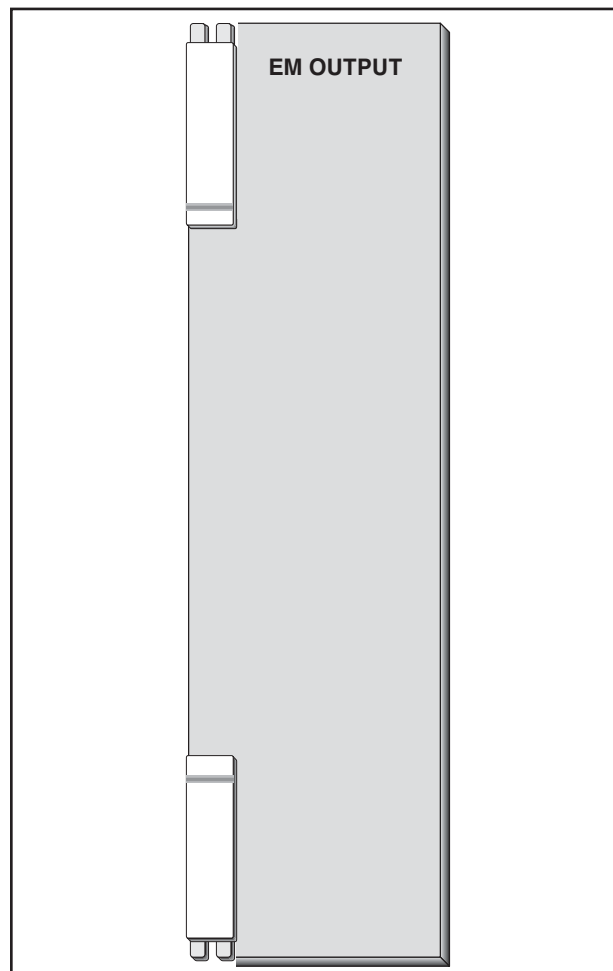

Figure 16–1. EM Output Module – Front Panel.

16.2 EM Output Circuit Description

The EM Output Module provides six (6) relay contacts for trip or guard output (see Figure 16-3). The contacts are rated to make and carry 30A for 100ms at 250 Vdc. Continuous switching of 125 Vdc at 0.5A or 250 Vdc at 0.25A is provided.

The three-state voltage output from the Receiver Logic Module is as follows:

- Trip 1 (+20V)
- Trip 2 (-20V)
- Guard (+20V)

The trip input (pin C-20) and guard input (pin A-20) is applied to voltage comparators and associated components, as follows:

- Trip 1 (I2b)
- Trip 2 (I2a)
- Guard (I2c)

A trip voltage comparison occurs at 10 Vdc, with 10% hysteresis for noise immunity. The comparator output goes low (-14 Vdc) when the correct voltage is applied.

NOTE

The following paragraph applies only to style G02 modules, not to style G01 modules.

The outputs of I2a and I2b drive I4a and I4b monostable multi-vibrators (one shots). These “one shots” extend the length of the trip output. The trip extension (not normally used in the U.S., but routinely used in some overseas applications)

is selectable from 0 to 400 milliseconds. Typically, you achieve a trip extension of 100ms by placing JU13 and JU14 in 100–200ms and adjusting R45 and R46 to the maximum counter-clockwise position. If you place JU13 or JU14 in the 0–100ms position, you should not adjust R45 or R46 to less than 1K Ω to prevent over dissipating I4a and I4b.

The outputs of I2a and I2b for style G01 modules (or the outputs of I4a and I4b for style G02 modules) turn “ON” the PNP transistor (QN1c for Trip 1 or QN1d for Trip 2), which then supplies a +15 Vdc voltage to jumpers JU1 through JU6. The guard input turns “ON” PNP transistor QN1b, which also supplies a +15 Vdc voltage to jumpers JU1 through JU6.

Jumpers JU1 through JU6 work, basically, the same. Using JU1 as an example, the +15 Vdc voltage flows through resistor R22 to the base of Transistor Q7, turning Q7 “ON”. When the current reaches 42mA at the Q7 emitter, Q1 turns “ON”, removing the base drive to Q7. This allows Q7 to operate as a constant current source. The high-speed operation of relay K1 is achieved by operating the 12V relay at 40V with this current source.

Diodes D1, D2, and D3 provide snubbing circuits (eliminates spikes and return currents) for relay K1.

16.3 EM Output Troubleshooting

You can use normal troubleshooting techniques to isolate and check faulty components.

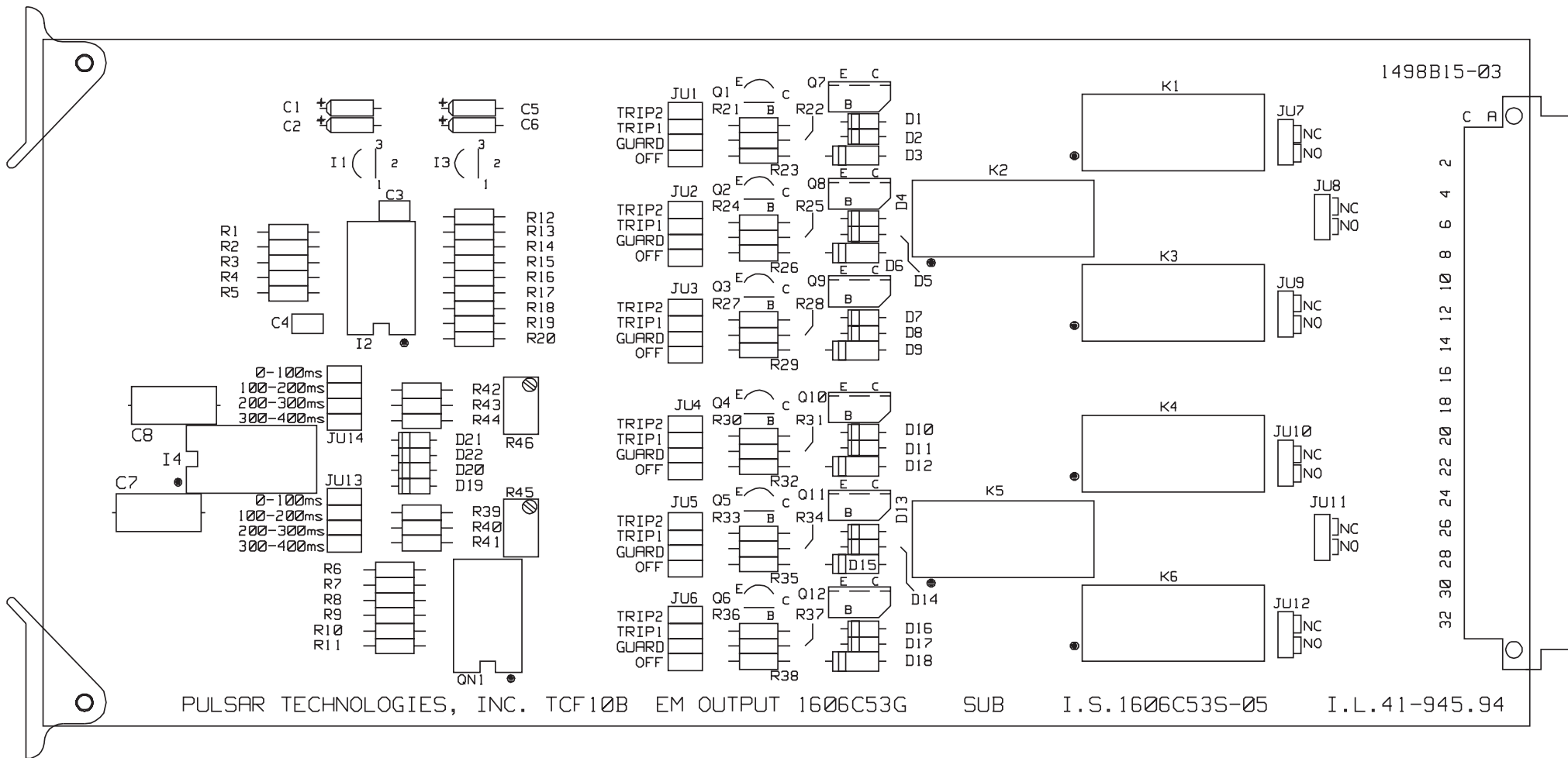
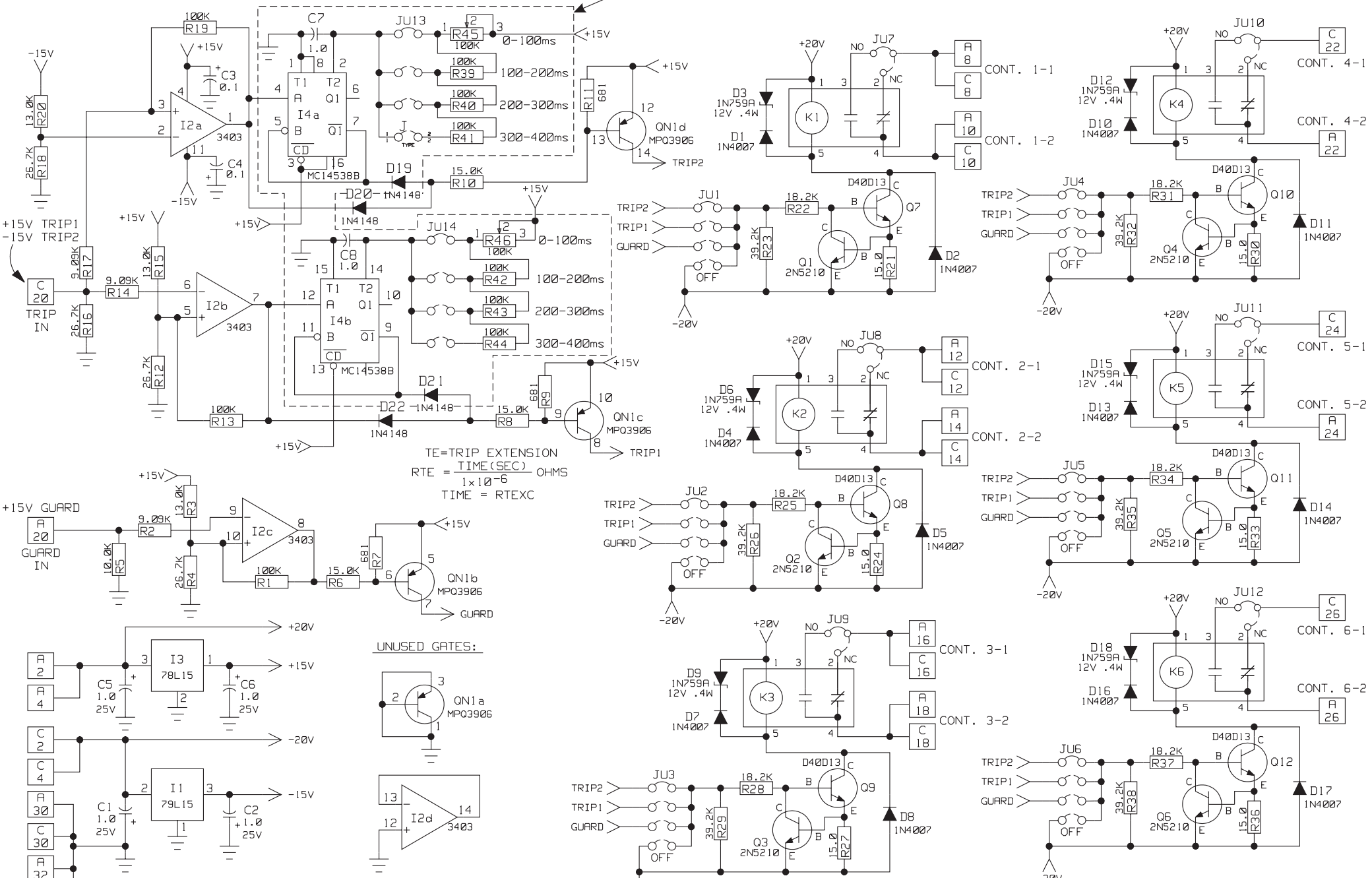

Figure 16-2. TCF-10B EM Output Component location (1498B15).

Figure 16-3. TCF-10B EM Output Schematic (1606C53).

Optional Trip Extension Circuit



TE=TRIP EXTENSION

$$RTE = \frac{TIME(SEC)}{1 \times 10^{-6}} \text{ OHMS}$$

$$TIME = RTEXC$$

UNUSED GATES:

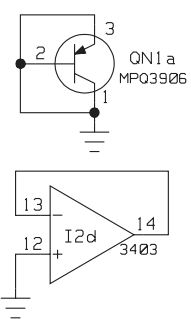

- NOTES:
 1. ALL RESISTORS ARE 1/4W, 1% IN OHMS, UNLESS OTHERWISE NOTED.
 2. ALL CAPACITORS ARE IN MICRO FARADS, UNLESS OTHERWISE NOTED.

Chapter 17. Optional Voice Adapter Module

Table 17–1. C020-VADMN Styles and Descriptions.

Schematic	C030-VADMN-4
-----------	--------------

Group	Description
G01	Optional Voice Adapter Module

17.1 Voice Adapter Module Description

The Voice Adapter Module provides voice communications between terminals of the TC-10B and TCF-10B carrier systems. You can use the same module in either type of system simply by changing the DIP switches (see the "DIP Switch Settings" section later in this chapter). This chapter describes the module's use in TCF-10B carrier systems. (For complete information on using the module with a TC-10B carrier system, please refer to the TC-10B System Manual.)

The Voice Adapter Module also provides signaling, which includes an on-board audible alarm and LED to indicate incoming calls. For the TCF-10B, voice communication is in full-duplex mode. That is, you can send and receive at the same time, just like talking and listening on your home telephone. This is because, in a TCF-10B system, the module transmits on one frequency and receives on another.

17.1.1 TCF-10B Operation (Full-Duplex)

Figure 17-1 provides a simplified look at how the Voice Adapter Module operates when used in a TCF-10B carrier system. It works like this:

Receive Direction

1. The Universal Receiver Module in the TCF-10B system outputs an audio signal to the Voice Adapter Module.
2. The Voice Adapter Module filters the audio signal and runs it through an expander.
3. The Voice Adapter Module then amplifies the audio signal and sends it to the handset. (You can adjust the receive audio level by turning the RECEIVE AUDIO potentiometer on the module's front panel.)

Transmit Direction

1. The Voice Adapter Module filters the audio signal coming from the handset and runs it through a compressor.
2. The Voice Adapter Module then amplifies the audio signal and sends it to the Keying Module.

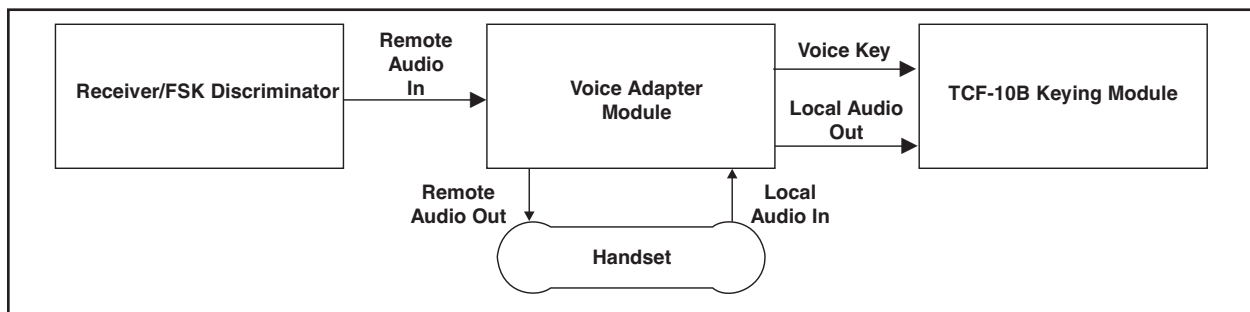

Figure 17–1. Voice Adapter Module – Simplified Signal Flow Diagram.

17.1.2 Handset Operation

You can connect the handset (without a push-to-talk switch) to the TCF-10B in two different ways:

Option 1: Local Connection

Plug the handset into the Voice Adapter Module at the front panel "HANDSET" jack.

Option 2: Remote Hookswitch Connection

Remotely connect a hookswitch assembly which supports a handset to the TCF-10B rear panel (see Figure 17-6).

Option 1: Using the Local Handset Configuration

To configure your system for this option:

1. Set the DIP switch (SW1) to its normal, or default, settings as shown in Table 17-4.
2. Connect an external alarm circuit in series with the TB5 terminal block on the TCF-10B rear panel. Use the wiring diagram in Figure 17-7 as a guide.

To initiate signaling with this option:

1. Plug the handset (without a push-to-talk switch) into the Voice Adapter Module at the front panel "HANDSET" jack.
2. Press the calling push-button, labeled "CALLING P.B.", on the Voice Adapter Module's front panel (see Figure 17-2).

This rings the other end of the system.

To answer a ring (at the receiving end) with this option, plug a handset (without a push-to-talk switch) into the Voice Adapter Module's front panel "HANDSET" jack. This stops the ringing by turning off the alarm circuit(s).

Option 2: Using the Remote Hookswitch Configuration

To configure the Voice Adapter Module for this option:

1. Set the DIP switch (SW1) to its normal, or default, settings as shown in Table 17-4.
2. Cradle a handset (without a push-to-talk switch) on a hookswitch assembly in a location remote from the TCF-10B Voice Adapter Module.
3. Connect the hookswitch assembly in series with both the external alarm circuit and the TCF-10B rear panel terminal block TB5. Use Figure 17-6 (hookswitch assembly) and Figure 17-7 (external alarm circuit) as guides.
4. Install a separate calling push-button in the remote location, near the handset. Use Figure 17-6 as a guide.

To initiate signaling with this option:

1. Lift the handset from the hookswitch assembly.
2. Press the calling push-button, labeled "CALLING P.B.", on the Voice Adapter Module's front panel (see Figure 17-2).

This rings the other end of the system.

To answer a ring (at the receiving end) with this option, lift the handset from its cradle. This stops the ringing by turning off the alarm circuit(s).

Using a Handset with a Push-To-Talk Button

If you are using a handset with a push-to-talk button in either of the above configurations, you initiate signaling by:

1. Lifting the handset from the hookswitch assembly.
2. Pressing the push-to-talk switch and the calling push-button simultaneously.

17.1.3 Electrical Characteristics

The Voice Adapter Module's electrical characteristics are shown in Table 17-2.

Table 17-2. Voice Adapter Module Electrical Characteristics.

Feature	Specification
Operating Temp Range	-20 – +60 deg. C (Ambient)
Audio Frequency Response	300 to 2,000 Hz (-3 dB)
Receiver Sensitivity	-74 dBm (50Ω)
AGC Dynamic Range	40 dB min Audio output ± 0.5 dB for R.F. level change -74 dBm to -34 dBm
Signaling Tone	370 Hz ± 7 Hz
Signaling Tone Detector	370 Hz ± 7 Hz
Transmit Audio	3.2V p-p (in limit) into 600Ω
Receive Audio Squelch	When RF input is below -80 dBm (Also jumper selectable to squelch with "push-to-talk" switch)
Powering	Module powered from +20V, common, and -20V power supply. Supply current is approximately 40mA from each supply.
External Handset & Signaling Inputs	Meets IEEE impulse and IEEE SWC tests (ANSI C37.90.1).
Alarm Terminals	Passes 2,500 Vdc hi-pot for one minute (normal open/normal closed, jumper selectable).

17.2 Voice Adapter Front Panel

The Voice Adapter Module's front panel is shown in Figure 17-2. It provides the following operator controls:

Calling Push-button (SW2)

This push-button, labeled "CALLING P.B.", activates the signaling oscillator.

Alarm LED (LE1)

This LED, labeled "ALARM", indicates when an incoming call is being received. At the same time the incoming signal activates this LED, it also activates the alarm relay and, if enabled, the audible alarm.

Receive Audio Level Adjustment (P1)

This potentiometer, labeled "RECEIVE AUDIO", adjusts the receive audio level.

Handset Jack (J2)

This jack, labeled "HANDSET", is for connecting the handset to the Voice Adapter Module. The handset schematic is shown in Figure 17-8.

17.3 Rear Panel Connections

The terminal block connections for the Voice Adapter Module are on the rear panel of the TCF-10B chassis. They are shown in Figure 3-4.

The Voice Adapter Module's terminal block connections are used as follows:

- TB5-1** External receiver output
- TB5-2** External microphone input
- TB5-3** Common
- TB5-4** Alarm signal (NO or NC)
- TB5-5** Alarm signal (NO or NC)
- TB5-6** Signaling input (external calling switch, to be returned to common when signaling).

17.4 Voice Adapter Module Settings

The Voice Adapter Module has three types of user-configurable settings. These include the jumper JMP1 and the DIP Switch SW1 on the PC board and the RECEIVE AUDIO potentiometer on the module's front panel.

17.4.1 Receive Audio Level Setting

You can adjust the receive audio level by turning the RECEIVE AUDIO potentiometer (P1) on the module's front panel. Turn it clockwise to increase the receive audio level; counter-clockwise to decrease it.

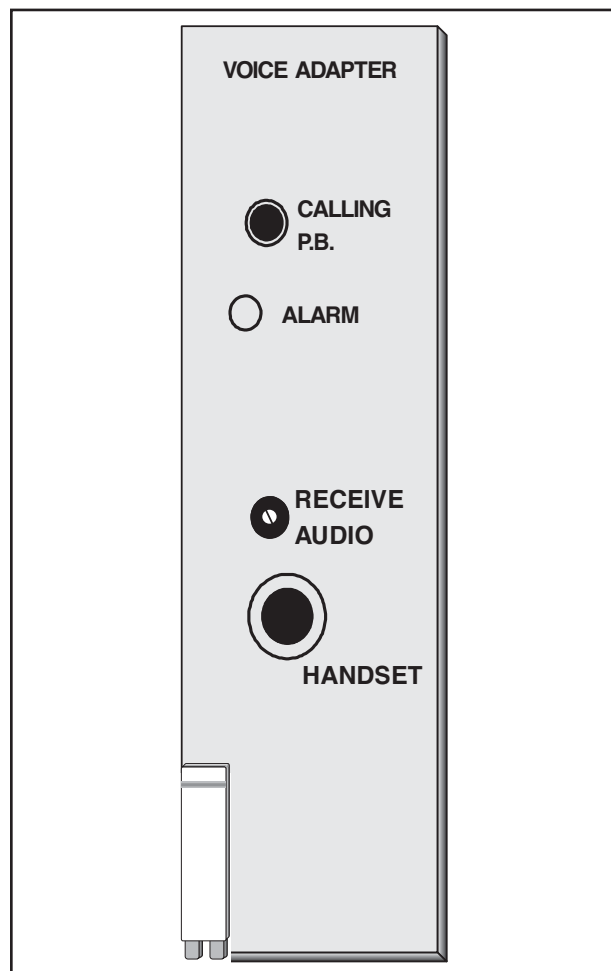

Figure 17-2. Voice Adapter Module – Front Panel.

17.4.2 Jumper Setting

The jumper JMP1 setting determines whether the external alarm connected to the rear panel (TB5-4, TB5-5) is normally open (NO) or normally closed (NC). The factory default is normally open.

17.4.3 DIP Switch Settings

The DIP switch (SW1) on the module's PC board lets you enable or disable several functions. Table 17-3 shows the function that is enabled for each of the four DIP switch positions when they are DOWN (CLOSED). When a switch position is UP (OPEN), its function is disabled. Table 17-4 shows the default settings when using the Voice Adapter Module in a TCF-10B carrier system.

Table 17-3. DIP Switch Setting Functions.

Position	Function when DOWN (CLOSED)
SW1-1	Pushing "CALLING P.B." (on front panel) generates a tone that gives an alarm
SW1-2	Receiving a carrier signal gives an alarm
SW1-3	When the handset is keyed, the earphone is muted
SW1-4	Enables the audible internal alarm (beeper)

Table 17-4. Default (Normal) Settings for TCF-10B Operation.

Position	Default (Normal) Setting
SW1-1	DOWN
SW1-2	UP
SW1-3	UP
SW1-4	DOWN

Figure 17-3. Voice Adapter Module Component location (C020VADMN).

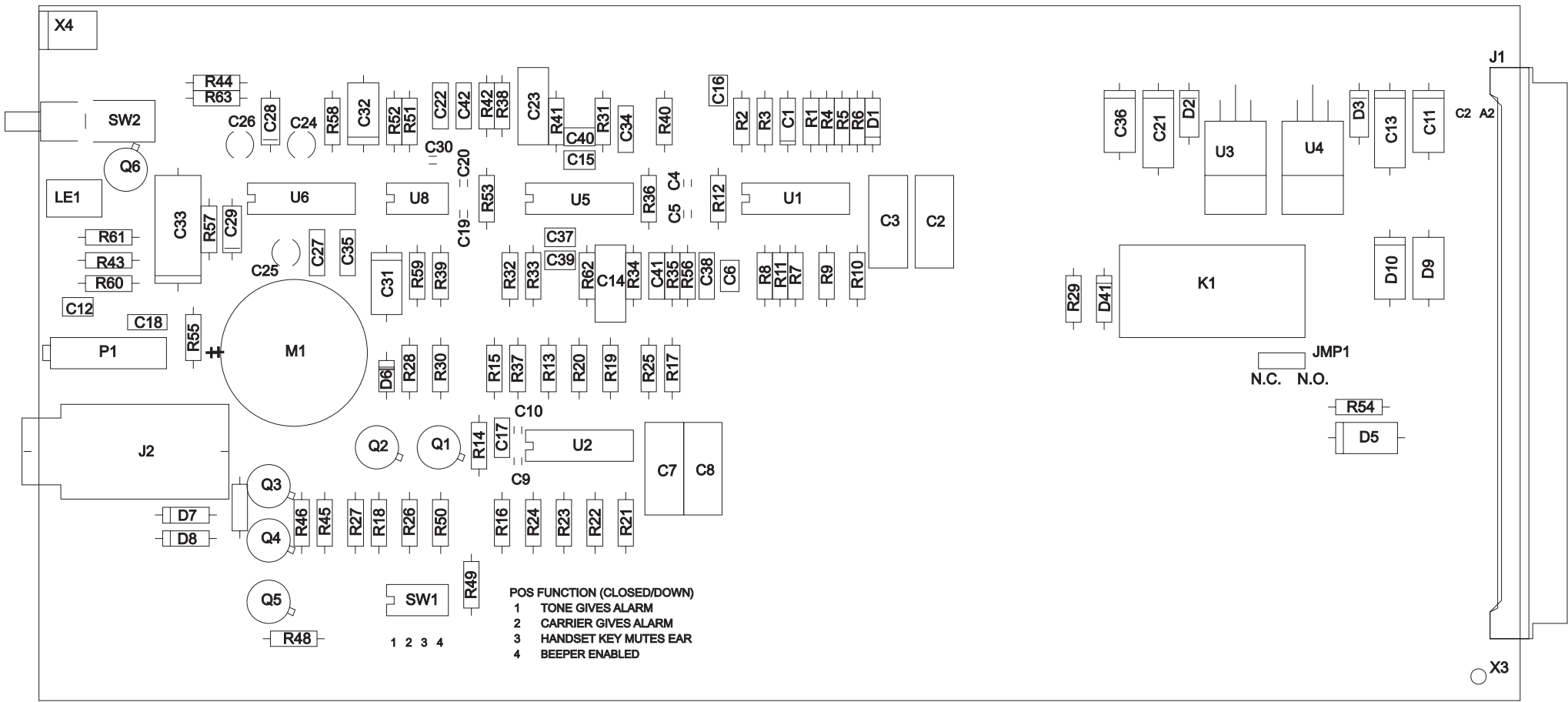

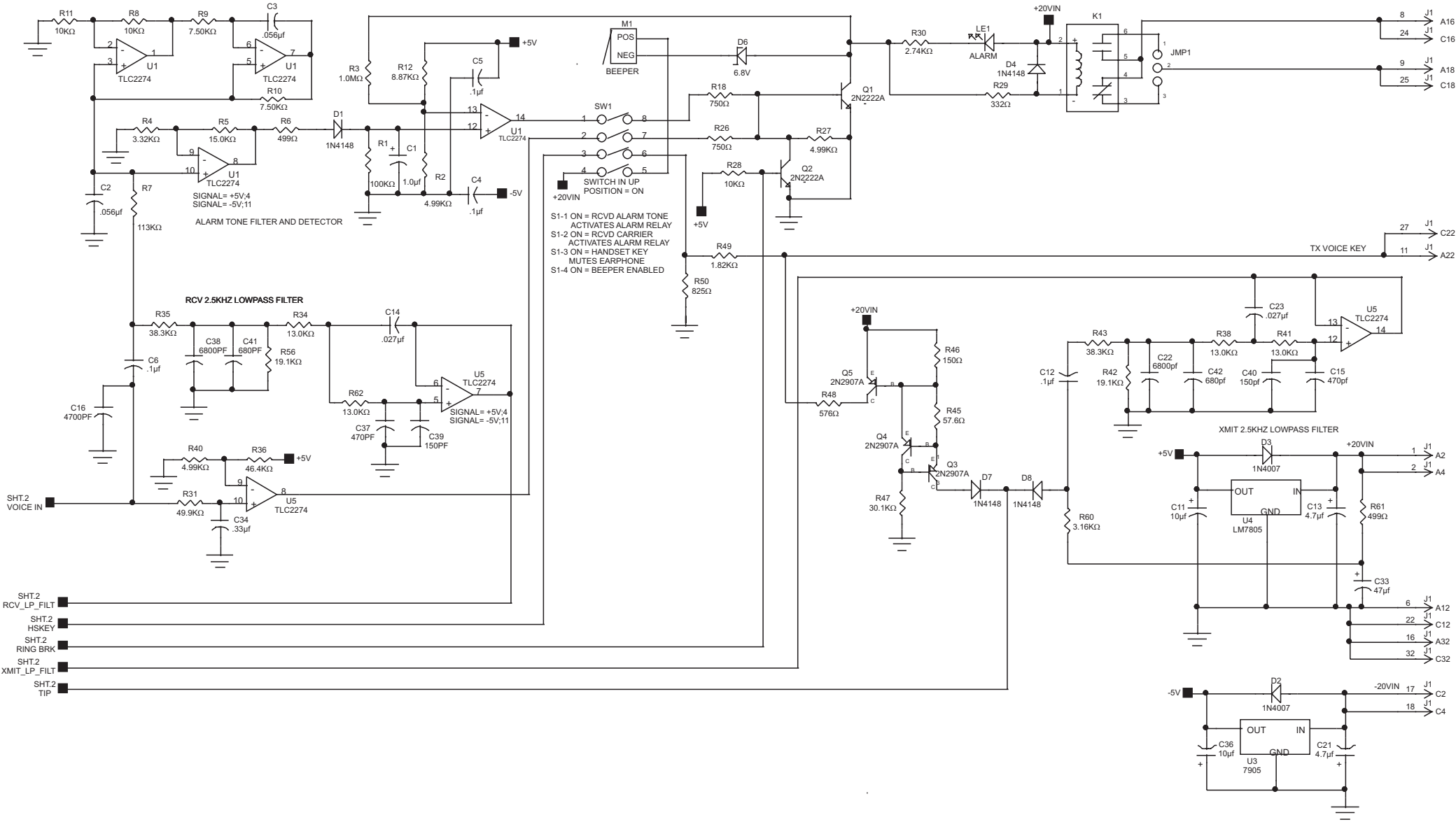
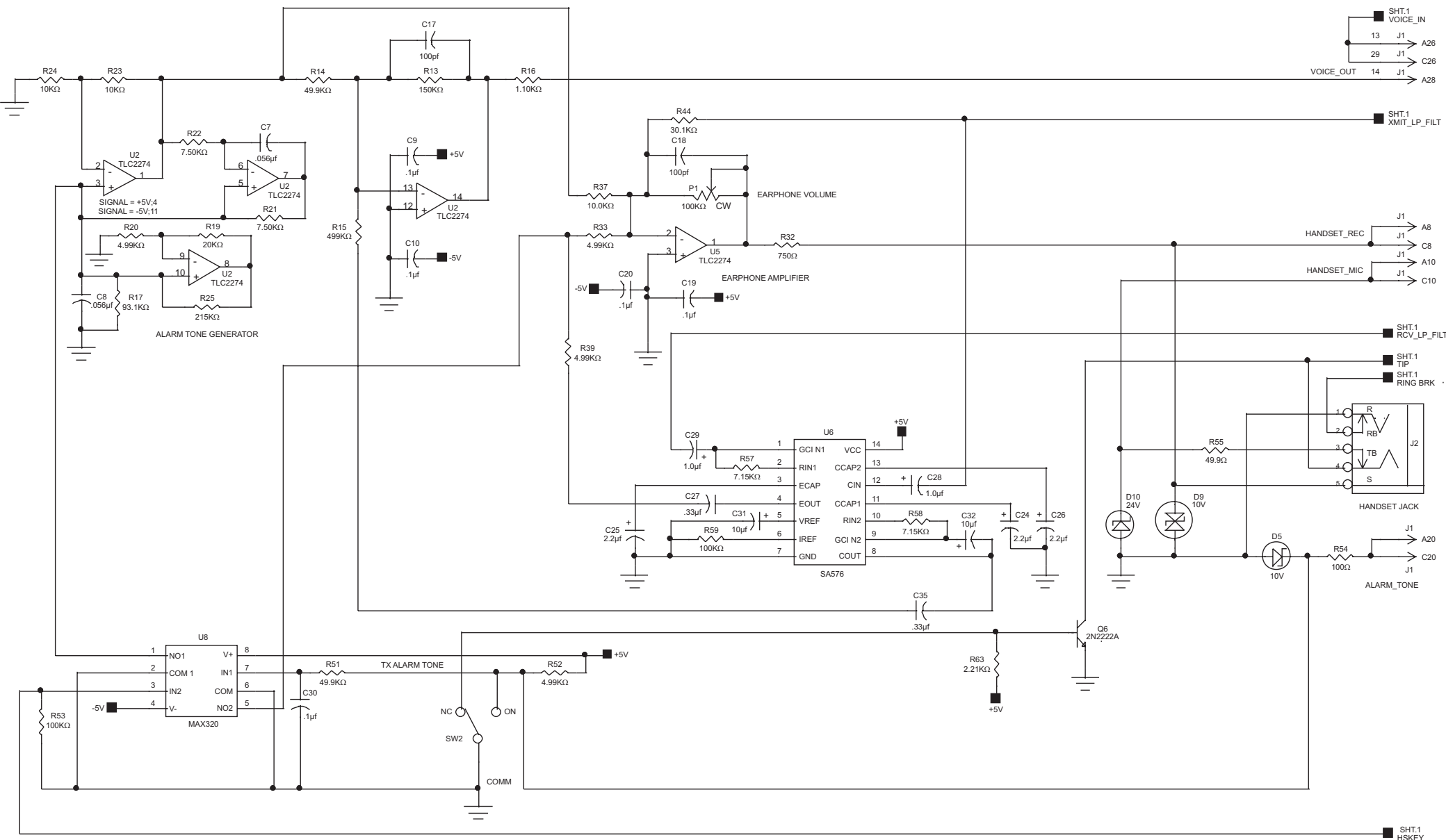

Figure 17-4. Voice Adapter Module Schematic (C030VADMN1) Sheet 1 of 2.

Figure 17-5. Voice Adapter Module Schematic (C030VADMN2) Sheet 2 of 2.



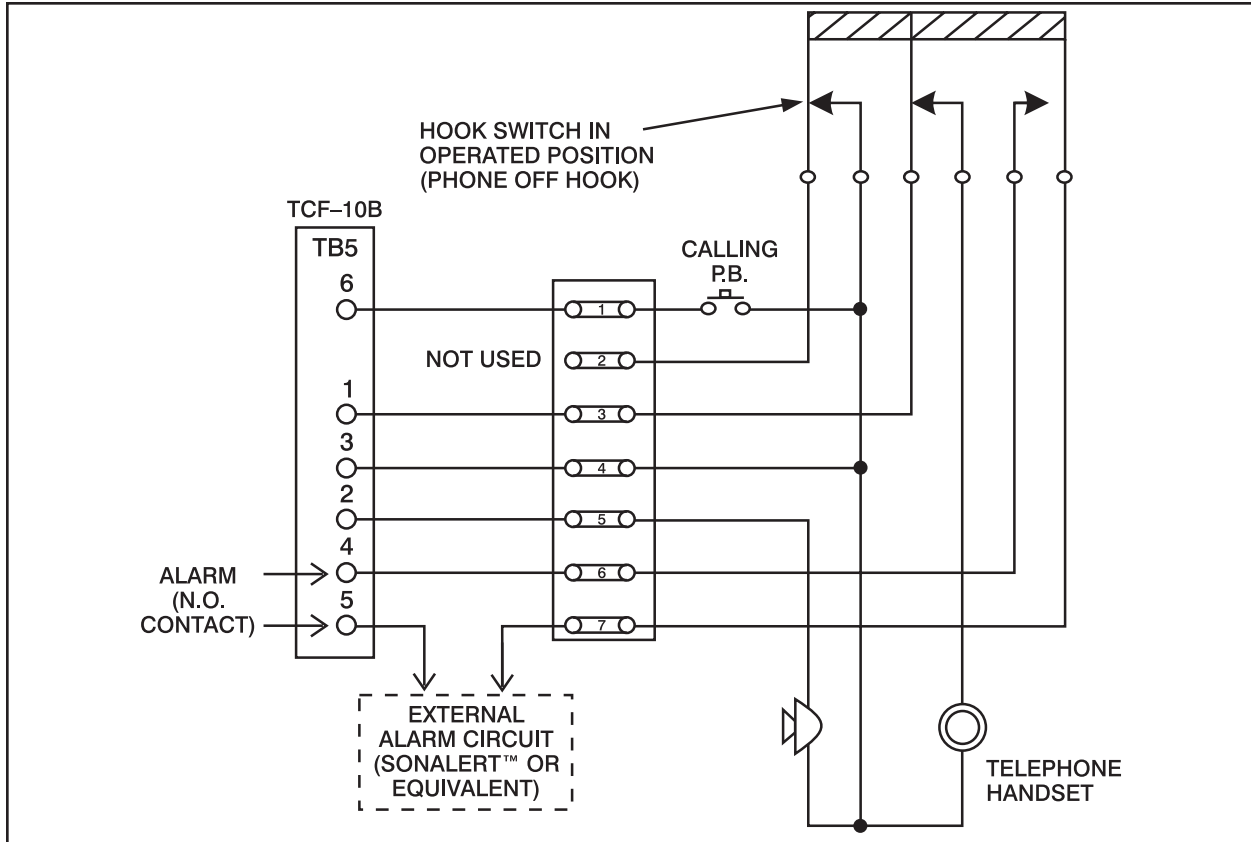

Figure 17-6. Connections for Remote Phone & External Alarm (9651A87).

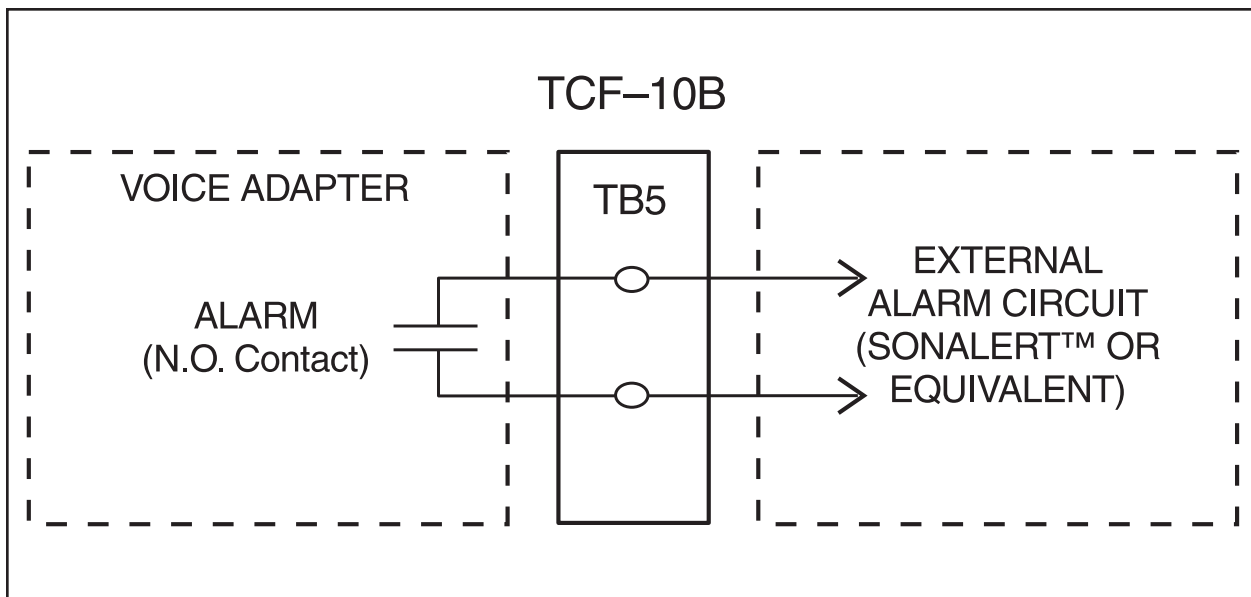
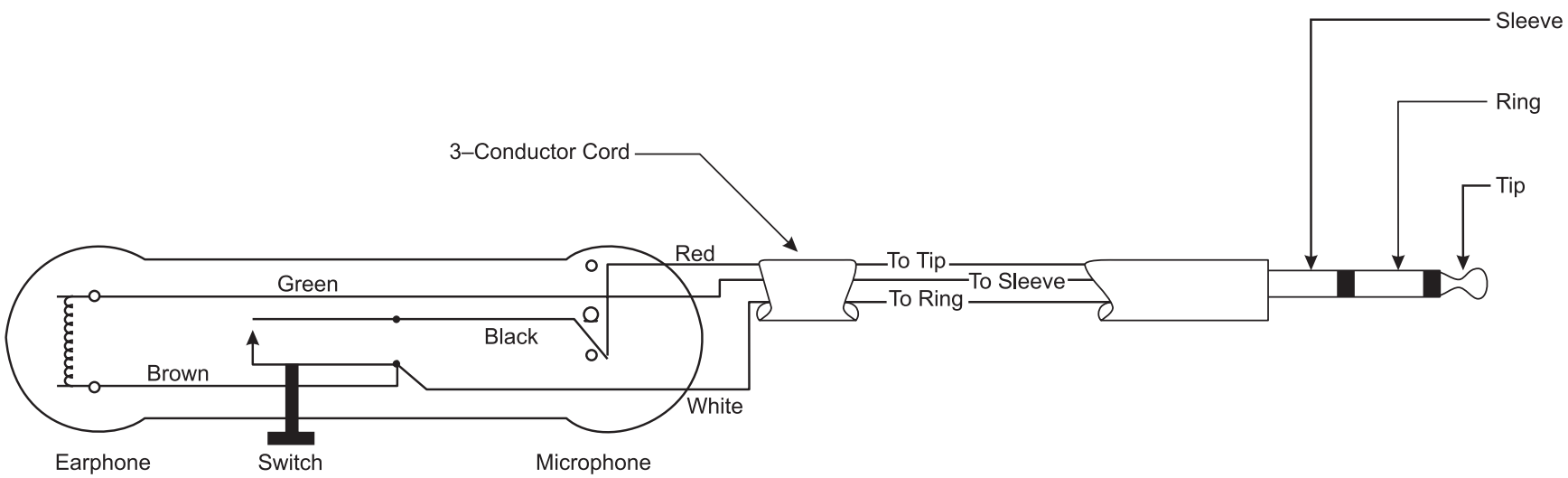

Figure 17-7. External Alarm Circuit for Use with Module Front Panel Jack (9651A88).

Figure 17-8. Handset schematic.



Chapter 18. Optional Trip Test Unit (TTU) Module

Table 18–1. 1610C01 Styles and Descriptions.

Schematic	1614C25-3
-----------	-----------

Group	Description
G02	Optional Trip Test Unit Transmitter

18.1 TTU Description

The optional Trip Test Unit is designed to test two-frequency or three-frequency transfer trip units using the TCF–10B. Two TTU transmitters, one at each end of the line, are needed to perform this testing function. The schematic diagram of the TTU board (daughter board on the Transmitter Module) is shown at the end of this chapter. This board plugs onto the main Transmitter board (see Figure 18-6). The backplane PC board for the TC/TCF–10B has been modified to bring out the extra inputs and outputs needed for the TTU operation. Note, however, that backplanes (1353D62G01) having a sub lower than five (5) cannot be used with the TTU.

The Timing Diagrams for the TTU are shown at the end of this chapter.

The Trip Test Unit can be used to functionally test the transmitters and receivers at both ends of a two terminal line with having only a person at one end. Please note it is not applicable to three terminal lines.

The Trip Test Unit on the transmitter works in conjunction with the local receiver as well as the remote receiver and transmitter to test the ability of the system to shift to the trip frequency and receive the trip frequency at the opposite end. Available outputs are two relays with jumper selectable contacts (normally open or normally closed), one for trip sent and one for trip received. Trip Sent is available on TB4-8, and TB4-9. Trip Received is available on TB3-7 and TB3-8. Backplane connections are shown in Figure 3-4.

For 2-frequency TCF-10B systems, the Trip Test Unit can be set for a “real” trip or a “checkback”



CAUTION

- IF THE UNIT IS SET FOR A REAL TRIP, THEN CAUTION SHOULD BE TAKEN TO OPEN THE TRIP CIRCUIT PATH SO AS NOT TO MISTAKENLY TRIP OUT A BREAKER OR LOCKOUT RELAY ON A DIRECT TRANSFER TRIP SYSTEM.
- THE RECEIVER LOGIC MODULE MUST BE SET FOR “GUARD BEFORE TRIP” LOGIC (SW2-4 OR SW2-5 SET DOWN)

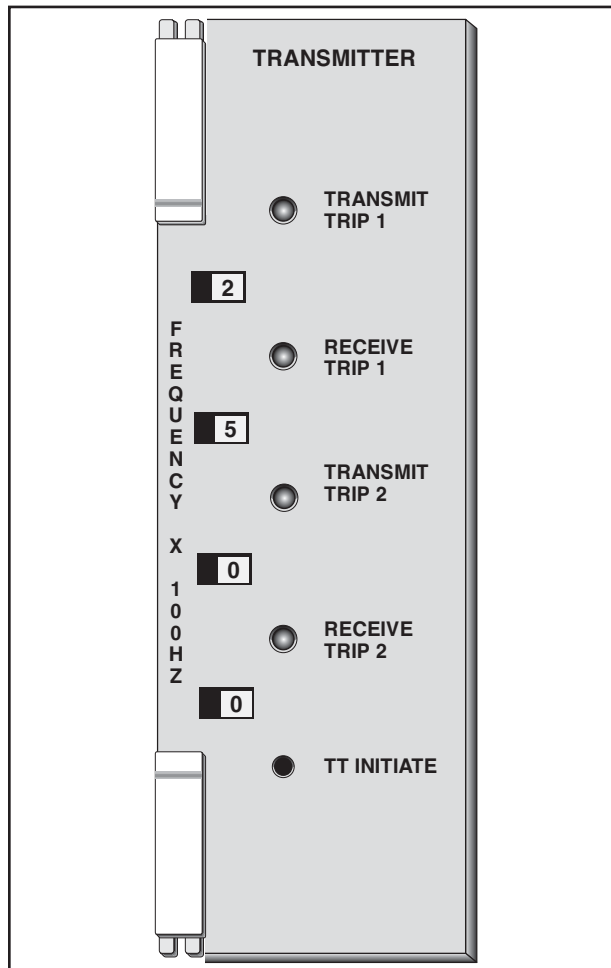

Figure 18–1. TTU Module – Front Panel.

trip. The “real” trip will produce an output of the receiver logic card TRIP and the electromechanical output card relays programmed for TRIP. A “Checkback” Trip setting will provide only a checkback trip output from the receiver logic card, which can be used to pick up an auxiliary relay or indicating light. Only the “checkback” trip setting can be used for 3-frequency systems.

This setting is made at the time of manufacturing per the customer’s request. Should you desire to change the setting, the jumpers JU6 through JU9 must be changed as well as the timer setting modified.

18.1.1 Two Frequency Applications Real Trip Scenario

In this application, the local end, at which you initiate a Trip Test, will receive a real TRIP as well as a CHECKBACK TRIP, but the remote end will only produce a CHECKBACK TRIP. When using this application the end that initiates the trip would have to be disconnected from the trip relays.

JU6, JU7, JU8 & JU9 set in position 2-3, P4 set for 3 seconds.

Refer to the timing diagrams at the end of this chapter.

When a trip test is initiated, the local transmitter shuts down for 2 seconds. The remote end receiver will see this as a loss of channel. After 2 seconds, the local transmitter then keys to the trip frequency for 2 seconds. The remote end recognizes this as a TTU command and the remote receiver will then produce a CHECKBACK TRIP and key the remote transmitter to the trip frequency for 2 seconds. The local end receiver sees that as a REAL TRIP and produces a TRIP and CHECKBACK TRIP output from the logic card and the electromechanical card.

The following is the response of the TTU Transmitter & Receiver Logic front panel LEDs when a trip test is initiated locally.

LEDs on TTU Transmitter:

- Local: Transmit Trip 1 on 2 sec.
- Remote: 1. Receive Trip 1 on 0.5 sec
2. Transmit Trip 1 on 2 sec.

LEDs on Receiver Logic Module:

- Local: 1. Good Channel & Guard,
2. Good Channel, Checkback Trip & Trip
- Remote: 1. Good Channel & Guard
2. All LEDs off
3. Good Channel & Checkback Trip

18.1.2 Two Frequency Application Checkback Trip Scenario

In this application, both the local and remote ends shift to “checkback” trip. No trip outputs have to be disconnected.

JU6, JU7 & JU8 set in position 1-2, JU9 set in position 2-3, P4 set for 7 seconds.

Refer to the timing diagrams at the end of this chapter.

When a trip test is initiated, the local transmitter shuts down for 1.5 seconds. The remote end receiver will see this as a loss of channel. After 1.5 seconds, the local transmitter then keys to the trip frequency for 0.5 second. The remote end recognizes this as a TTU command and the remote receiver will then produce a CHECKBACK TRIP and shut down the remote transmitter for 2 seconds. The remote transmitter is then keyed to the trip frequency for 0.5 second. This in turn produces a loss of channel and CHECKBACK TRIP (without a real TRIP) at the local end.

The following is the response of the TTU Transmitter & Receiver Logic front panel LEDs when a trip test is initiated locally.

LEDs on TTU Transmitter:

- Local: 1. Transmit Trip 1 on 0.5 sec.
2. 1.5 sec. with no LEDs,
3. Receive Trip 1 on 0.5 sec.
- Remote: 1. Receive Trip 1 on 0.5 sec.
2. Transmit Trip 1 on 0.5 sec.

LEDs on Receiver Logic Module:

- Local: 1. Good Channel & Guard
2. All LEDs off
3. Good Channel & Checkback Trip

- Remote:
1. Good Channel & Guard
 2. All LEDs off
 3. Good Channel & Checkback Trip

18.1.3 Three Frequency Applications Checkback Trip Scenario

In this application, both the local and remote ends shift to “checkback” trip. No trip outputs have to be disconnected. Both trips (DTT & unblock/POTT) are checked. DTT is Trip 1 (LF) and unblock/POTT trip is Trip 2 (HF).

JU6, JU7, JU8 & JU9 set in position 1-2, P4 set for 7 seconds.

Refer to the timing diagrams at the end of this chapter.

When a trip test is initiated, the local transmitter shuts down for 1.5 seconds. The remote end receiver will see this as a loss of channel. After 1.5 seconds, the local transmitter then keys to the lower trip frequency for 0.5 second. The remote end recognizes this as a TTU command and the remote receiver will then produce a CHECKBACK TRIP1 and shuts down the remote transmitter for 2 seconds. The remote transmitter is then keyed to the lower trip frequency for 0.5 second. This in turn produces a loss of channel and CHECKBACK TRIP1 (without a TRIP1) at the local end’s receiver. Then the system needs to check for the TRIP2 function. In a similar way, the local end will send a CHECKBACK TRIP2 to the remote and the remote receives and then returns a CHECKBACK TRIP2 to the local receiver.

The following is the response of the TTU Transmitter & Receiver Logic front panel LEDs when a trip test is initiated locally.

LEDs on TTU Transmitter:

- Local:
1. Transmit Trip 1 on 0.5 sec.
 2. 1.5 sec. with No LEDs
 3. Receive Trip 1 on 0.5 sec.
 4. 1.5 sec. with No LEDs
 5. Transmit Trip 2 on 0.5 sec.
 6. 1.5 sec. with No LEDs
 7. Receive Trip 2 on 0.5 sec.

- Remote:
1. Receive Trip 1 on 0.5 sec
 2. Transmit Trip 1 on 0.5 sec.
 3. 1.5 sec. with No LEDs
 4. Receive Trip 2 on 0.5 sec.
 5. 1.5 sec. with No LEDs
 6. Transmit Trip 2 on 0.5 sec.

LEDs on Receiver Logic Module:

- Local:
1. Good Channel & Guard
 2. All LEDs off
 3. Good Channel & Checkback Trip
- Remote:
1. Good Channel & Guard
 2. All LEDs off
 3. Good Channel & Checkback Trip

18.1.4 TTU Inputs & Outputs

There is one input and two outputs.

Input: You initiate a test sequence either by pressing S1 (TT initiate) on the front panel or by applying the appropriate voltage to terminals 6 & 7 of TB-4 on the backplane. Jumper J5 must be set to the appropriate external keying voltage when external keying is used.

Outputs: There is a Receive Trip contact output on terminals 7 & 8 of TB-3. It is energized by the receipt of Trip 1 or Trip 2. There is a Transmit Trip contact output on terminals 8 & 9 of TB-4. It is energized when either Trip 1 or Trip 2 is sent.

18.1.5 Receiver Only/Transmitter Only Chassis Applications

When you use the TTU with a TCF-10B transceiver, the TTU Transmitter module (Figure 18-5) is all that is required to provide the trip test function. When you are using a TCF-10B receiver only chassis or a TCF-10B transmitter only chassis, an additional plug-in jumper board is required in each chassis. The TCF-10B transmitter only chassis requires a “CLI & Discriminator” jumper board (1614C59G01) to be plugged into the CLI Discriminator slot (3rd from left side) of the chassis. The TCF-10B receiver only chassis requires a “Transmitter” jumper board (1614C59G02) to be plugged into the transmitter slot of the chassis. Use two, 2-wire shielded cables, or a four-wire shielded cable to interconnect the receiver only and the transmitter only

chassis. The jumper board information and inter-connecting cables are shown on the following pages.

Table 18-2. TTU Jumper boards.

For TTU use with

**TCF-10B (Receiver Only)
TCF-10B (Transmitter Only)**

1. TRANSMITTER JUMPER BOARD (1614C59G02) GOES IN REC. ONLY CHASSIS & PLUGS INTO TRANSMITTER SLOT. ||

JUMPER	A/C32	TO	C30	COMMON	TB3-8
	A14	TO	A30	NOISE	TB3-7
	C12	TO	C20	CENT. FREQ.	TB4-9
	A12	TO	A20	HI/LO FREQ.	TB4-8
	C14	TO	A22	LOW LEVEL	TB4-7

2. CLI & DISCRIMINATOR JUMPER BOARD (1614C59G01) GOES IN TRANS. ONLY CHASSIS & PLUGS INTO REC. (BOTTOM AUX. BOARD) SLOT. ||

JUMPER	A/C30	TO	C/A20	COMMON	TB2-5
	A8	TO	C/A18	NOISE	TB2-4
	A10	TO	C/A16	CENT. FREQ.	TB2-3
	A28	TO	C/A14	Hi/LO FREQ.	TB2-2
	C28	TO	C/A12	LOW LEVEL	TB2-1

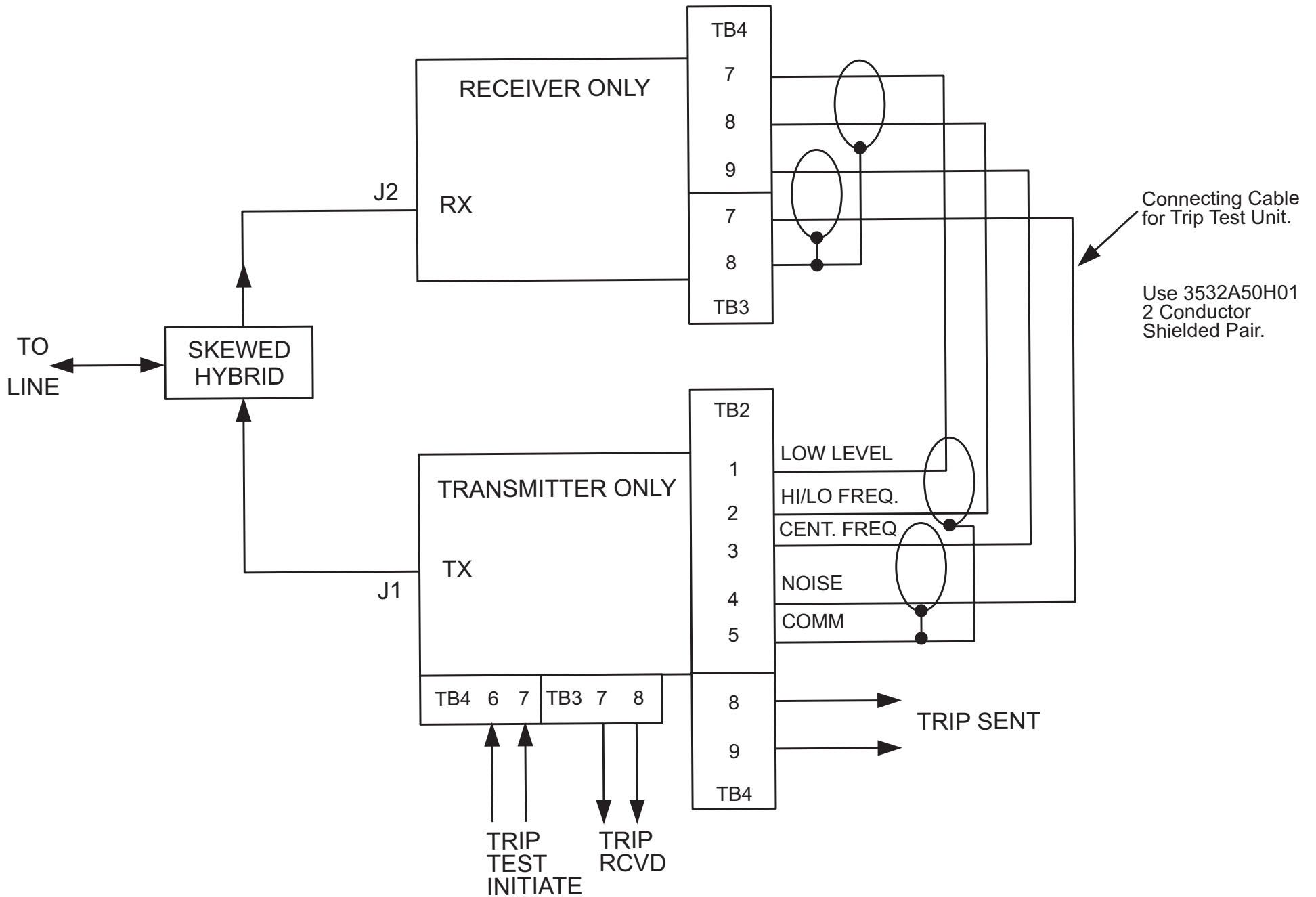
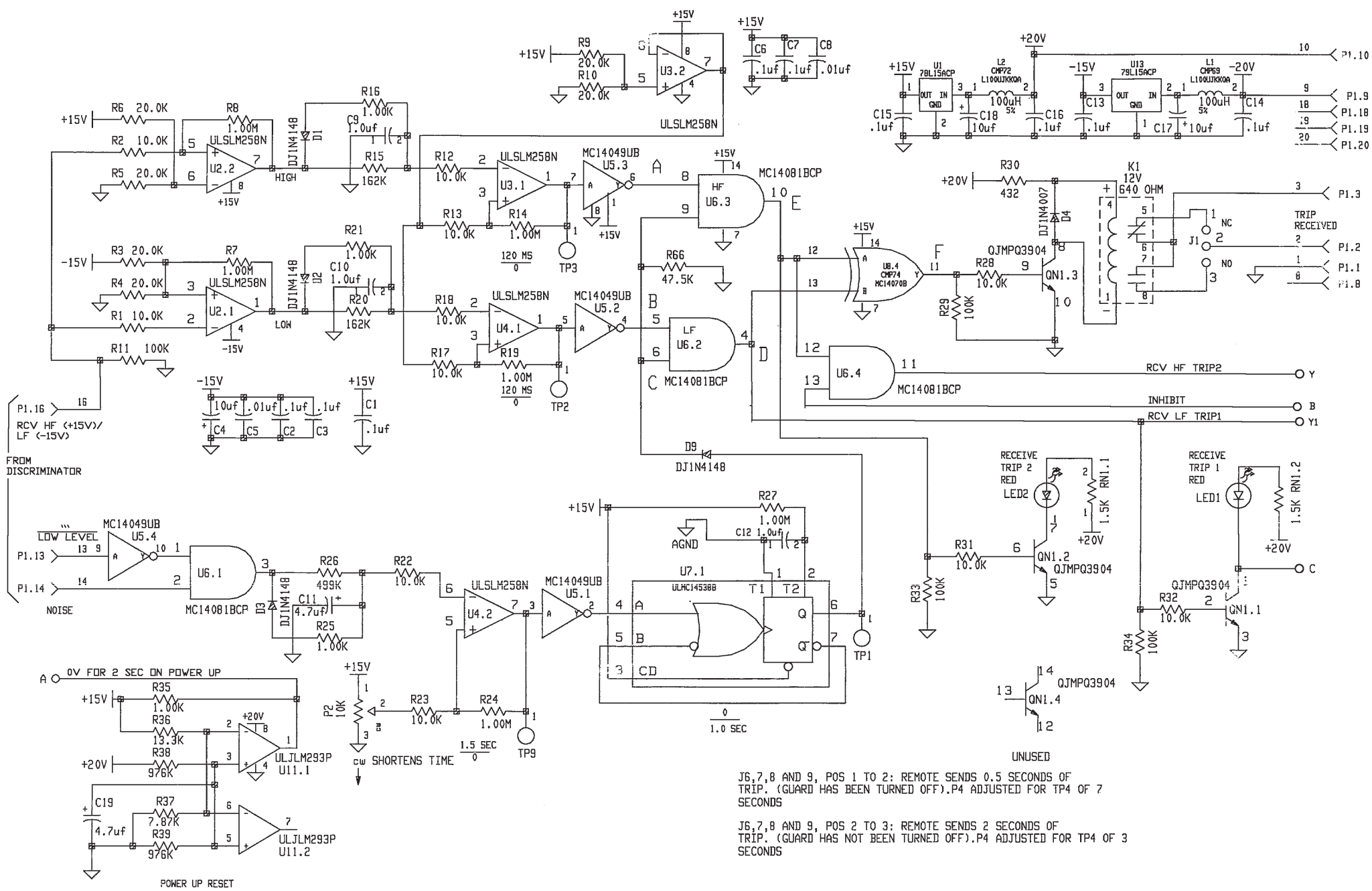

Figure 18–2. Interconnecting cables for TTUs in Receiver only/Transmitter only chassis.

Figure 18-3. Schematic of TTU Daughter Board (1614C25; Sheet 1 of 2).



J6,7,8 AND 9, POS 1 TO 2: REMOTE SENDS 0.5 SECONDS OF TRIP. (GUARD HAS BEEN TURNED OFF). P4 ADJUSTED FOR TP4 OF 7 SECONDS

J6,7,8 AND 9, POS 2 TO 3: REMOTE SENDS 2 SECONDS OF TRIP. (GUARD HAS NOT BEEN TURNED OFF). P4 ADJUSTED FOR TP4 OF 3 SECONDS

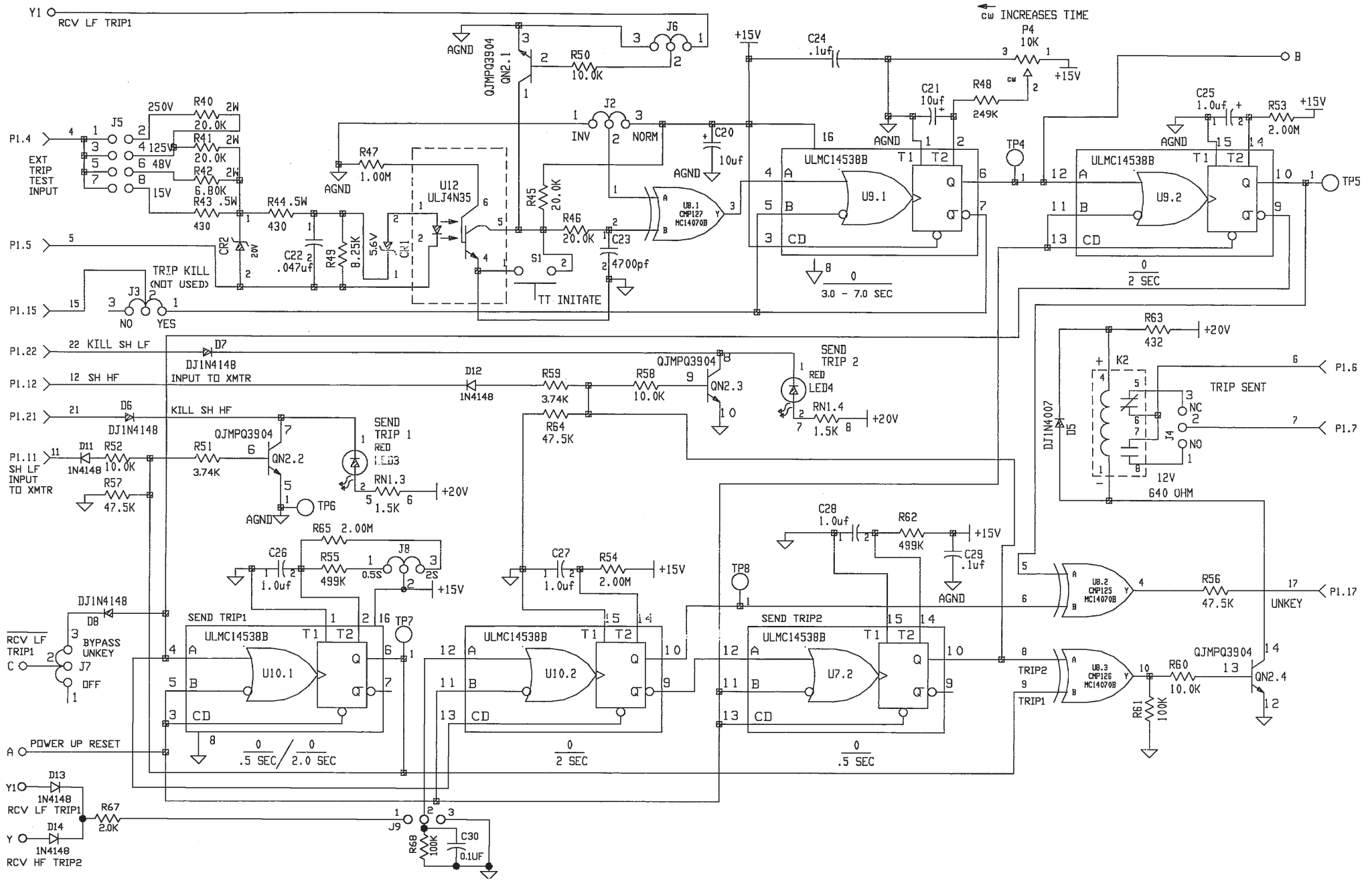
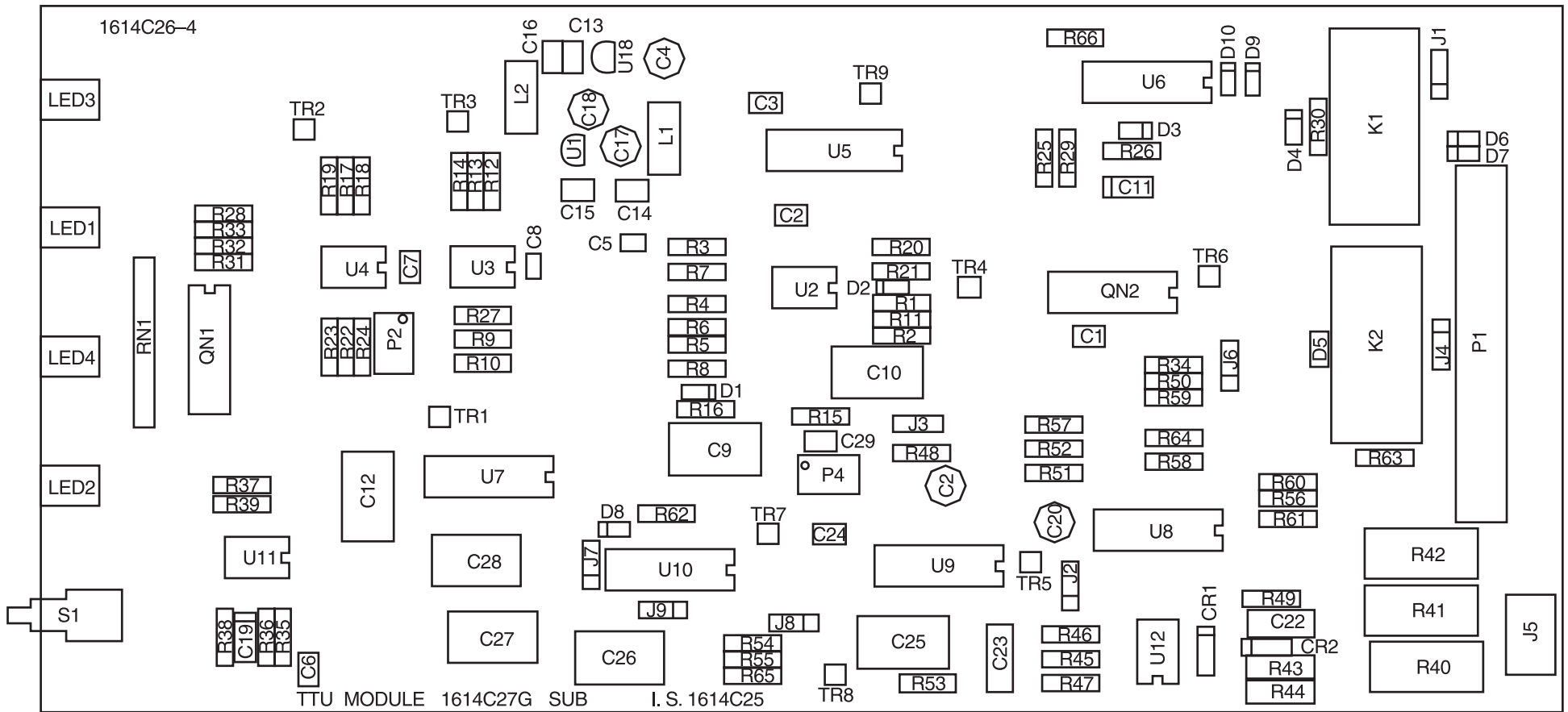
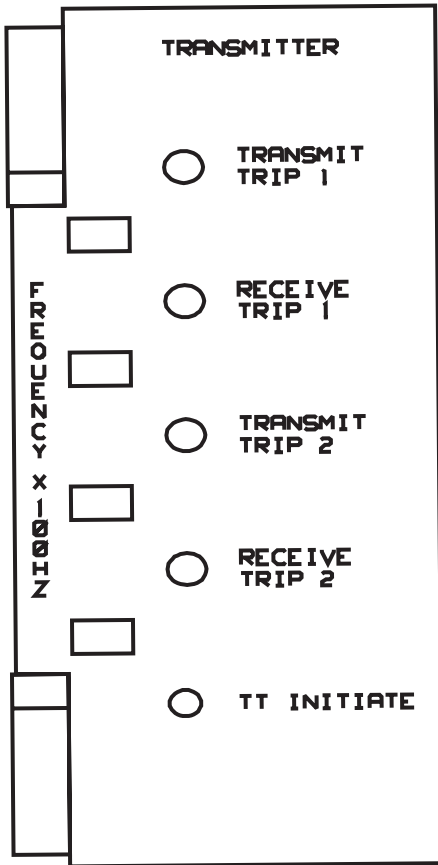

Figure 18-4. Schematic of TTU Daughter Board (1614C25; Sheet 2 of 2).

Figure 18-5. Component Layout for TTU Daughter Board (1614C26; Sheet 2 of 2).





102

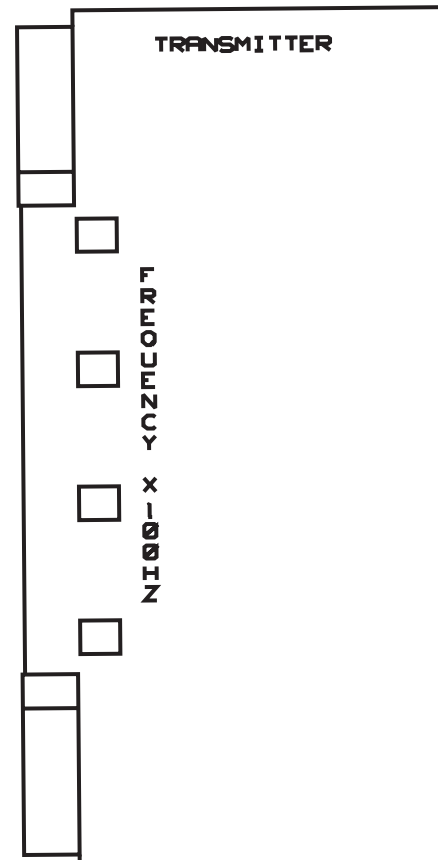

001

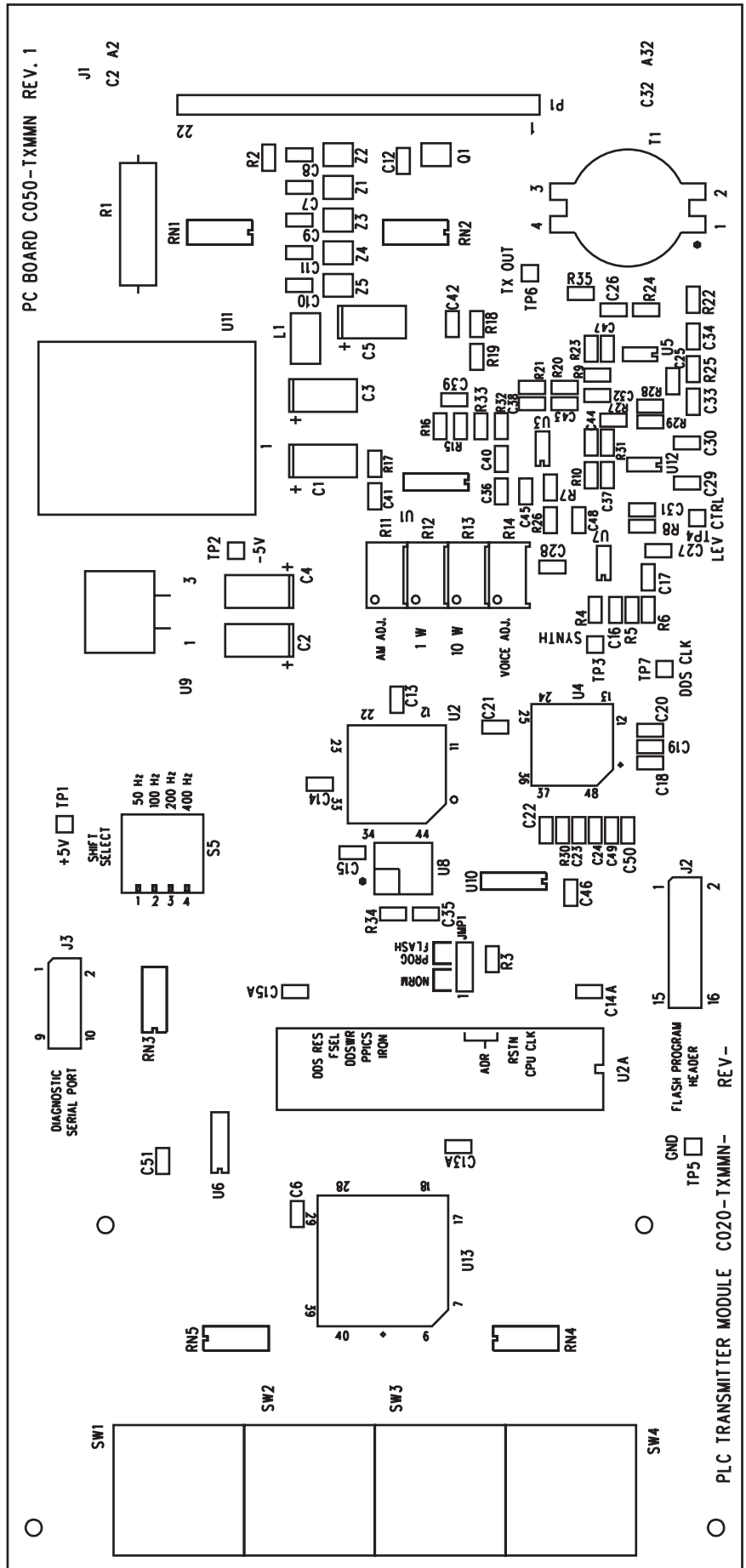
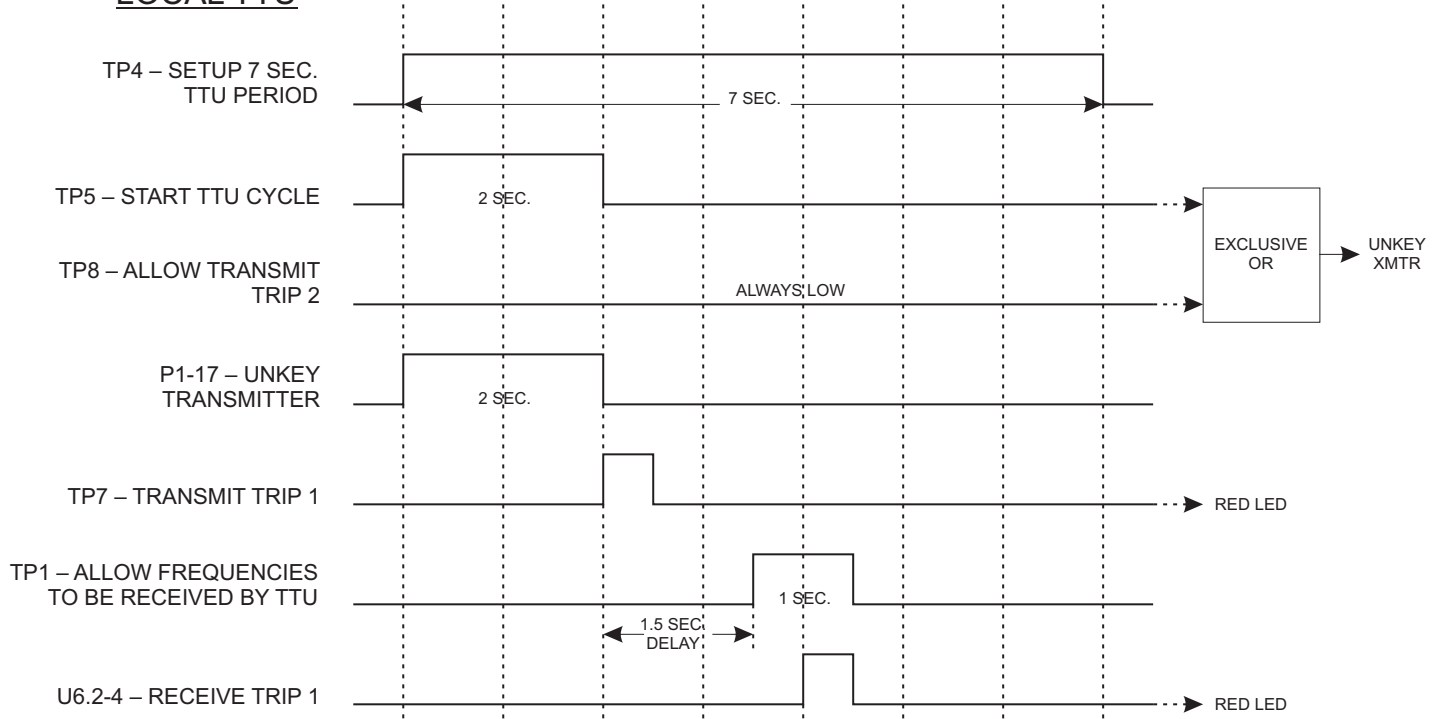
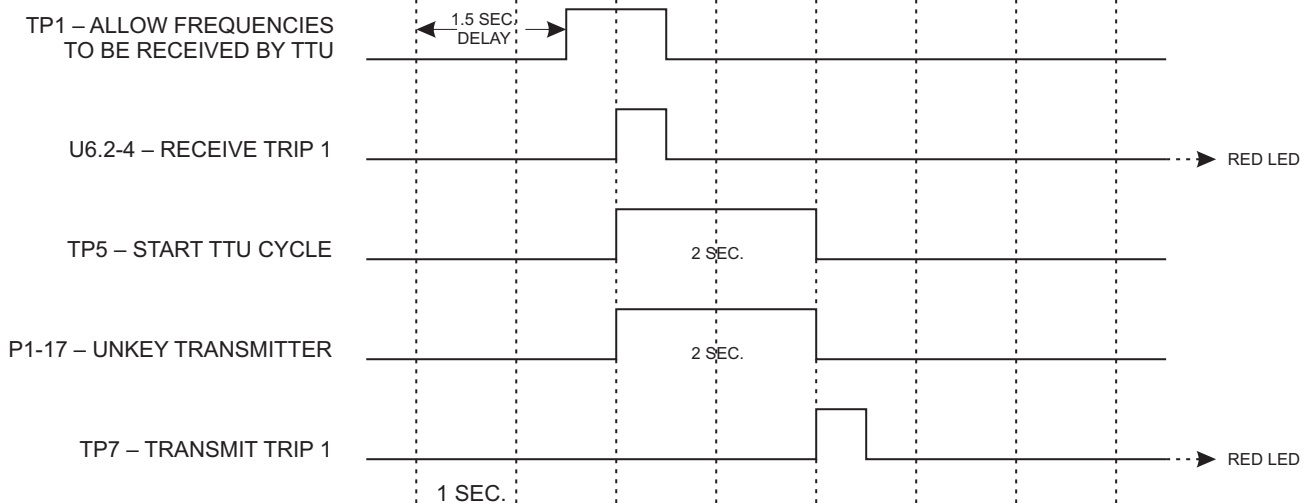

Figure 18-6. Transmitter Board (C020-TXMMN).

LOCAL TTU



REMOTE TTU



TTU SETTINGS: P4 SET FOR 7.0 SEC, J6-8 SET FOR POS.1-2, J9 SET FOR POS. 2-3

Figure 18-7. TTU 2-Frequency Checkback Trip Timing Diagram.

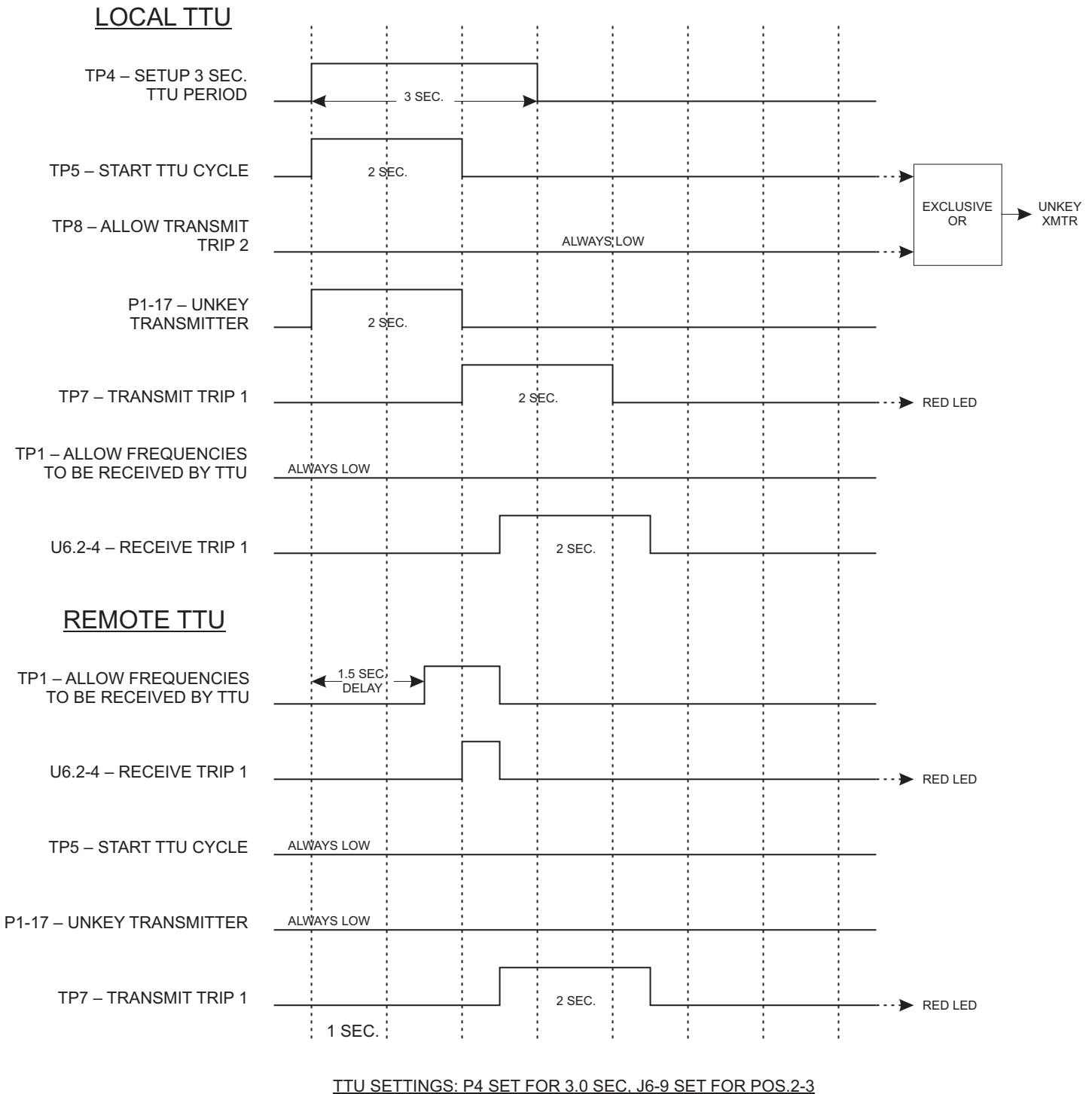

Figure 18–8. TTU 2-Frequency Real Trip Timing Diagram.

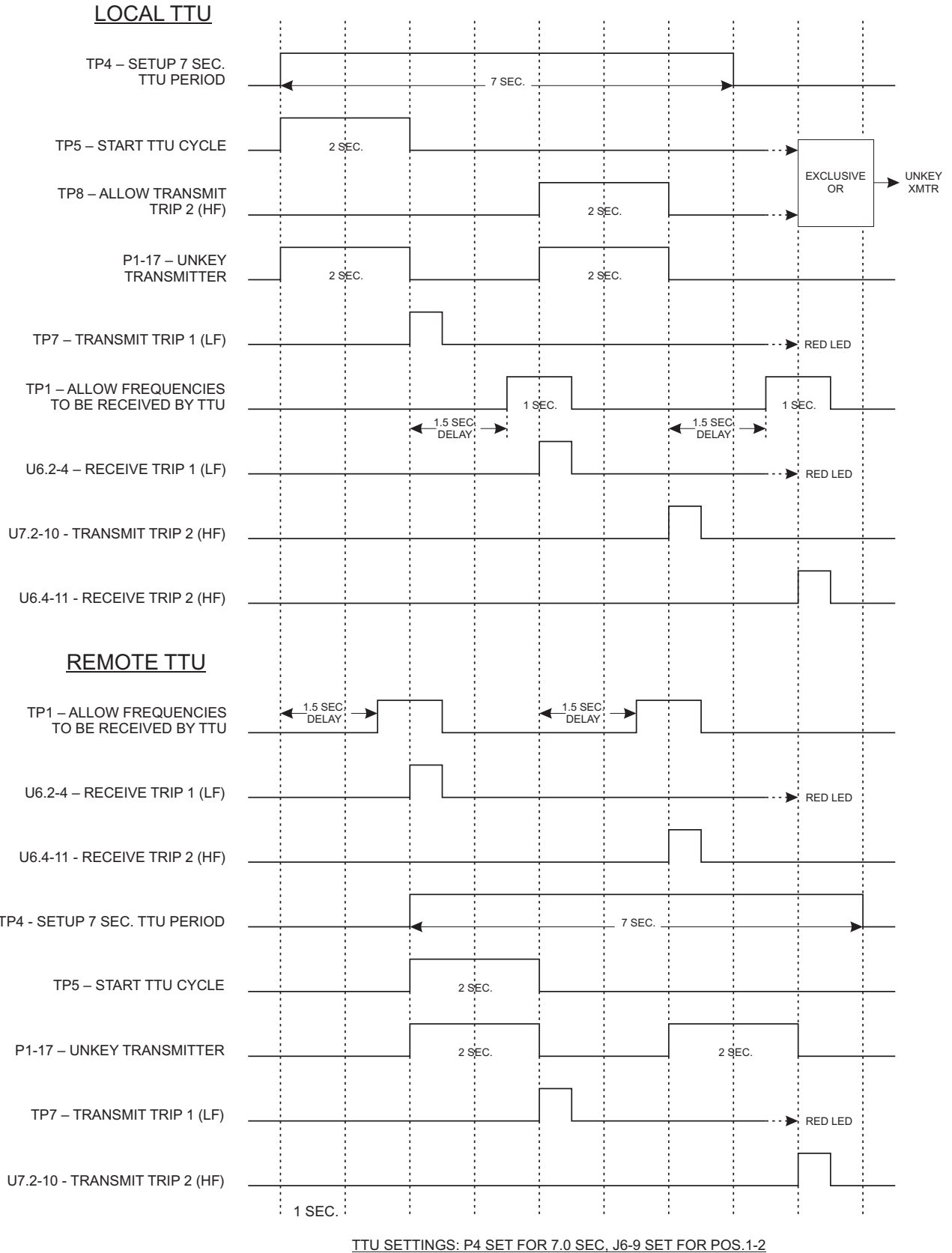

Figure 18-9. TTU 3-Frequency Checkback Trip Timing Diagram.

Pulsar