

# UPLC™

## Universal Power-Line Carrier



### Application Manual CU44-VER04

**AMETEK®**  
POWER INSTRUMENTS

AMETEK Power Instruments  
4050 N.W. 121st Avenue  
Coral Springs, FL 33065  
1-800-785-7274  
+1-954-344-9822  
[www.pulsartech.com](http://www.pulsartech.com)

**Pulsar**

THE BRIGHT STAR IN UTILITY COMMUNICATIONS

May 2012

**Pulsar**

# **UPLC™**

## **Application Manual**

### **Main Chapters**

<b>Ordering Information</b>	<b>1</b>
<b>Product Description</b>	<b>2</b>
<b>Applications</b>	<b>3</b>
<b>Test Equipment</b>	<b>4</b>
<b>Installation/Configuration Procedure</b>	<b>5</b>
<b>Maintenance</b>	<b>6</b>
<b>Optional Testing Facilities</b>	<b>7</b>
<b>Protocols</b>	<b>8</b>

**Detailed Tables of Content for main topics, figures & tables, can be found on pages vi – xii.**

## Important Change Notification

This document supercedes the previous version of the UPLC™ Application Manual. The following list shows the most recent publication date for the new information. A publication date in **bold type** indicates changes to that information since the previous publication. Note that only significant changes, i.e., those changes which affect the technical use and understanding of the document and the UPLC™ equipment, are reported. Changes in format, typographical corrections, minor word changes, etc. are not reported. Note that in some cases text and graphics may have flowed to a different page than in the previous publication due to formatting or other changes. Also, lines of programming code may have wrapped due to publication formatting.

Each reported change is identified in the document by change bars, ||, placed to its left and/or right, just like the ones on this page.

	<u>Chapter Number</u>	<u>Publication Date</u>	<u>Page Number</u>
	front section	<b>May 2012</b>	ii,
	Chapter 1	June 2009	
	Chapter 2	<b>May 2012</b>	3
	Chapter 3	June 2009	
	Chapter 4	July 2006	
	Chapter 5	June 2009	
	Chapter 6	October 2007	
	Chapter 7	July 2006	
	Chapter 8	<b>May 2012</b>	1-7



## **IMPORTANT**

**W**e recommend that you become acquainted with the information in this manual before energizing your UPLC™ system. Failure to do so may result in injury to personnel or damage to the equipment, and may affect the equipment warranty. If you mount the carrier set in a cabinet, it must be bolted to the floor or otherwise secured before you swing out the equipment, to prevent the installation from tipping over.

You should not remove or insert printed circuit modules while the UPLC™ is energized. Failure to observe this precaution can result in undesired tripping output and can cause component damage.

AMETEK does not assume liability arising out of the application or use of any product or circuit described herein. AMETEK reserves the right to make changes to any products herein to improve reliability, function or design. Specifications and information herein are subject to change without notice. All possible contingencies which may arise during installation, operation, or maintenance, and all details and variations of this equipment do not purport to be covered by these instructions. If you desire further information regarding a particular installation, operation, or maintenance of equipment, please contact your local Ametek representative.

Copyright © Ametek

ALL RIGHTS RESERVED

AMETEK does not convey any license under its patent rights nor the rights of others.

## **ESD Warning!**

***YOU MUST BE PROPERLY GROUNDED, TO PREVENT DAMAGE FROM STATIC ELECTRICITY, BEFORE HANDLING ANY AND ALL MODULES OR EQUIPMENT FROM AMETEK.***

*All semiconductor components can be **damaged** by the discharge of static electricity. Be sure to observe all Electrostatic Discharge (ESD) precautions when handling modules or individual components.*

## Preface

### Scope

This manual describes the functions and features of the *Universal Power-Line Carrier*. It is intended primarily for use by engineers and technicians involved in the installation, alignment, operation, and maintenance of the *UPLC™*.

### Equipment Identification

The *UPLC™* equipment is identified by the Catalog Number on the chassis nameplate.

### Warranty

Our standard warranty extends for 60 months after shipment. For all repaired modules or advance replacements, the standard warranty is 90 days or the remaining warranty time, whichever is longer. Damage clearly caused by improper application, repair, or handling of the equipment will void the warranty.

### Equipment Return & Repair Procedure

To return equipment for repair or replacement:

1. Call your Ametek representative at **1-800-785-7274**.
2. Request an **RMA number** for proper authorization and credit.
3. Carefully pack the equipment you are returning.

Repair work is done most satisfactorily at the factory. When returning any equipment, pack it in the original shipping containers if possible. Be sure to use anti-static material when packing the equipment. Any damage due to improperly packed items will be charged to the customer, even when under warranty.

Ametek also makes available interchangeable parts to customers who are equipped to do repair work. When ordering parts (components, modules, etc.), always give the complete Ametek style number(s).

4. Make sure you include your return address and the RMA number on the package.
5. Ship the package(s) to:

**AMETEK**  
**Power Instruments**  
**4050 NW 121st Avenue**  
**Coral Springs, FL USA 33065**

## **Overview of this Document**

- Chapter 1 – Ordering Information
- Chapter 2 – Product Description
- Chapter 3 – Applications
- Chapter 4 – Test Equipment
- Chapter 5 – Installation/Configuration Procedure
- Chapter 6 – Maintenance
- Chapter 7 – Optional Testing Facilities

## **Contents of Carrier Set**

- Power Supply (Main)
- Power Supply (Redundant) Optional
- Power Amplifier (Main)
- Power Amplifier (Redundant) Optional
- Display Board
- Aux. Display board – with either USB or DB9 connector
- Input/Output Board – optional 4-trip duty outputs available
- Transceiver Board
- Ethernet Board – optional
- Aux. Power Supply Board – optional for powering 5V, 20V, 20 or 200 mA outputs
- Motherboard (Backplane)

## Contents – Main

<b>Topic</b>	<b>Page No.</b>
Ordering Information .....	1-1
Standard Nomenclature .....	2-1
Chassis .....	2-1
Modules .....	2-1
Functional Description .....	2-5
Keying Logic .....	2-6
FSK Receiver Logic .....	2-11
Jumpers .....	2-13
Backplane .....	2-13
I/O Module .....	2-13
Power Supply Module .....	2-14
Aux. Power Supply Module .....	2-14
Input/Output Connections .....	2-17
Specifications .....	2-18
Protective Relay Applications Using Frequency Shift Carriers .....	3-1
Directional Comparison Unblocking .....	3-1
Permissive Overreaching Transfer Trip Systems .....	3-5
Permissive and Non-Permissive Underreaching Transfer Trip Systems .....	3-5
Dual Phase Comparison Unblocking Systems .....	3-7
Segregated Phase Comparison System .....	3-9
Direct Transfer-Trip Systems .....	3-11
Transformer Protection .....	3-13
Shunt Reactor Protection .....	3-15
Remote Breaker-Failure Protection .....	3-15
Direct Transfer Trip Channel Considerations .....	3-15
Special Considerations .....	3-16
Directional Comparison Unblocking (2-Frequency) .....	3-16
Transfer Trip: Overreaching, Underreaching or Direct (2-Frequency) .....	3-17
Phase Comparison Unblocking: Dual or Segregated (2-Frequency) .....	3-17
3-Frequency Systems .....	3-17
4-Frequency Systems .....	3-17
3-Terminal Line Applications .....	3-18
Hybrid Applications .....	3-18



<b>Topic</b>	<b>Page No.</b>
Examples .....	3-22
Protective Relay Applications Using ON/OFF Carriers .....	3-25
Directional Comparison Blocking .....	3-25
Phase-Comparison Blocking .....	3-25
Single Phase-Comparison Blocking, Current Only .....	3-33
Single-Phase, Distance-Supervised Comparison Blocking .....	3-34
Special Application Consideration .....	3-36
General File Format .....	5-1
Configuration File Modification .....	5-2
Logic Settings .....	5-3
Input/Outputs .....	5-4
Checkback Configuration .....	5-6
UPLC™ Configuration Report .....	5-8
Precautions When Selecting Test Equipment .....	6-1
Precautions When Using Test Equipment .....	6-1
Periodic Checks .....	6-1
Inspection .....	6-2
Solid-State Maintenance Techniques .....	6-2
Preliminary Precautions .....	6-2
Trouble-Detection Sequence .....	6-3
Servicing Components Soldered Directly to Terminals .....	6-3
Servicing Components Mounted Directly on Heat Sinks .....	6-4
Servicing Metal Oxide Semiconductor (MOS) Devices .....	6-4
ON/OFF Automatic Checkback General Description .....	7-1
PC Interface for Controlling Settings & Operation .....	7-1
User Selectable Encoded or Timed Carrier Operation .....	7-1
Optional Timed Communication Fallback .....	7-1
Optional Low Power Tests .....	7-1
Optional Carrier Recovery .....	7-1
Automatic Checkback Tests done Periodically or at User-Specified Times .....	7-2
Loopback Test Capability .....	7-2
Remote Communications .....	7-2
Automatic Clock Synchronization .....	7-2

<b>Topic</b>	<b>Page No.</b>
Available Alarms .....	7-2
System Configuration .....	7-2
Rear Panel Connections .....	7-2
Checkback Inputs .....	7-2
Checkback Options .....	7-4
Checkback Configuration .....	7-4
Setting Descriptions .....	7-4
Primary Comm Mode .....	7-4
Fallback Timed Comm .....	7-4
Last Remote .....	7-4
Interval Type .....	7-5
Carrier Recovery .....	7-5
Retries .....	7-5
Auto Tests .....	7-5
Low Power Tests .....	7-6
Checkback Time 1-4 .....	7-6
Checkback Period .....	7-6
Loopback Duration .....	7-6
Carrier Recovery Period .....	7-6
Carrier Recovery Window .....	7-6
Auto Clock Sync .....	7-7
Clock .....	7-7
Performing Checkback Tests .....	7-7
Manual Request from Web Pages .....	7-7
Automatic Timed Test .....	7-7
Automatic Periodic Test .....	7-7
Automatic Carrier Recovery .....	7-7
Remote-Intitiated Periodic Tests .....	7-7
Remote-Intitiated Timed Tests .....	7-8
Checkback Test Options .....	7-8
Keyed Carrier Timed Tests .....	7-8
Encoded Carrier Tests .....	7-9
Primary & Fallback Communications Modes .....	7-9
Communications Retries .....	7-9

<b>Topic</b>	<b>Page No.</b>
Troubleshooting .....	7-9
FSK Trip Test Facilities General Description .....	7-13
Two Frequency Applications Real Trip Scenario .....	7-13
Two Frequency Application Checkback Trip Scenario .....	7-13
Three Frequency Applications Checkback Trip Scenario .....	7-13
Trip Test Initiation .....	7-14
DNP 3 .....	8-1
DNP Binary Inputs (UPLC Inputs) .....	8-3
DNP Binary Inputs (UPLC Outputs) .....	8-4
DNP Analog Inputs (UPLC Analog Values) .....	8-7
IEC 61850 Protocol .....	8-8

## Contents – Figures

Figure No.	Page No.
2-1 Front Panel (with DB9 & USB) .....	2-2
2-2 Chassis .....	2-3
2-3 Chassis Dimensions .....	2-4
2-4 Functional Block Diagram (11x17 Fold-out) .....	2-21
2-5 FSK 2-Frequency Logic Diagram (11x17 Fold-out) .....	2-22
2-6 FSK 3-Frequency Logic Diagram (11x17 Fold-out) .....	2-23
2-7 FSK 4-Frequency Logic Diagram (11x17 Fold-out) .....	2-24
3-1 Simplified Unblock Receiver Logic .....	3-1
3-2 UPLC™ Transceiver Unit Connections, 2 Freq. set (Directional Comparison Unblock Relaying) .....	3-2
3-3a UPLC™ Programmed for 2F-Unblock Standard Configuration .....	3-3
3-3b UPLC™ Programmed for 2F-Unblock Standard Configuration .....	3-4
3-4 Basic Logic Diagrams for Directional Comparison Unblocking .....	3-5
3-5 Basic Logic Diagrams for Underreaching Transfer Trip Systems .....	3-7
3-6 Basic Operation of the Dual Phase Comparison Pilot Relaying System .....	3-8
3-7 Basic Segregated Phase Comparison Systems .....	3-10
3-8 Basic Operation of the Segregated Phase Comparison System .....	3-12
3-9 Conventional Phase Comparison Response to an Outfeed Condition Block Tripping .....	3-12
3-10 Typical Threshold Setting for Offset Keying .....	3-12
3-11 Response of Segregated Phase Comparison System with Offset Keying .....	3-13
3-12 Transceiver Unit Connections 2 Freq. set (Single Channel Direct Transfer Trip)	3-14
3-13 Direct Transfer Trip for Transformer Protection .....	3-15
3-14 Direct Transfer Trip for Shunt Reactor Protection .....	3-15
3-15 Dual Channel Direct Transfer Trip with Throwover to Single Channel .....	3-16
3-16 Dual Channel Direct Transfer Trip with Throwover to Single Channel .....	3-16
3-17 UPLC™ 3-Frequency System .....	3-18
3-18 Transceiver Unit Connections 3 Frequency Set (Unblock Relaying and Direct Transfer Trip) .....	3-19
3-19 Transceiver Unit Connections 4 Frequency Set (Unblock Relaying and Direct Transfer Trip) .....	3-20
3-20 Three terminal line application .....	3-21
3-21 Hybrid Connections – Two Transmitters .....	3-21
3-22 Hybrid Connections – Single Bi-Directional Channel .....	3-21
3-23 Hybrid Connections – Dual Bi-Directional Channel .....	3-23

<b>Figure No.</b>	<b>Page No.</b>
3-24 Hybrid Connections – Four Transmitters (Equal Losses).Two Dual-Channel Uni-Directional Channels	3-23
3-25 Hybrid Connections – (Equal Performances)	3-24
3-26a Basic Elements for directional-comparison blocking systems	3-26
3-26b Contact Logic (per Terminal)	3-26
3-26c Solid State Logic (per Terminal)	3-26
3-27a UPLC™ Applied with KA-4 Electromechanical Relay	3-27
3-27b UPLC™ Applied with KA-4 Electromechanical Relay (continued)	3-28
3-28 UPLC™ Programmed as ON/OFF (AM) PLC Channel (Std. Configuration)	3-29
3-29a GE Type EM Relays with UPLC™	3-30
3-29b GE Type EM Relays with UPLC™	3-31
3-29c GE Type EM Relays with UPLC™	3-32
3-30 Phase-Comparison Blocking, Basic Elements	3-33
3-31 Single Phase Comparison Blocking, Current Only Operation	3-34
3-32 Single Phase-Comparison Blocking, Distance-Supervised Operation	3-35
7-1 Checkback Page	7-3
7-2 Checkback Test Results	7-3
7-3 Maximum Checkback Configuration in Timed Communications Mode	7-5
7-4 Maximum Checkback Configuration in Coded Communications Mode	7-5
7-5 Timed Checkback Sequence (Master Initiation)	7-11
7-6 Timed Checkback Sequence (Remote 1 Initiation)	7-12
7-7 Example of The Trip Test Logic Page for 2-Frequency FSK	7-15
7-8 Example Page After a Successful Trip Test	7-15
7-9 Trip Test 2-Frequency Checkback Trip Timing Diagram	7-16
7-10 Trip Test 2-Frequency Real Trip Timing Diagram	7-17
7-11 Trip Test 3-Frequency Checkback Trip Timing Diagram	7-18
8-1 DNP Page	8-1
8-2 UPLC DNP Attributes Page	8-2
8-3 DNP Binary Inputs / UPLC Inputs Settings Page	8-3
8-4 DNP Binary Inputs / UPLC Outputs Settings Page	8-5
8-5 DNP Analog Inputs / UPLC Analog Values Settings Page	8-7
8-6 Goose Definition Page	8-9
8-7 Example Goose Subscription Block	8-11
8-8 UPLC™ .cid File	8-15

## Contents – Tables

Table No.	Page No.
1-1 UPLC™ Catalog Numbers . . . . .	1-2
2-1 Channel Type: On-Off, function: Directional or Phase Comparison Relaying with Stop Priority . . . . .	2-6
2-2 Channel Type: On-Off, function: Directional or Phase Comparison Relaying with Start Priority . . . . .	2-7
2-3 Channel: On-Off, function: Directional Comparison Relaying with KA-4 type Relaying System . . . . .	2-7
2-4 Channel: FSK, function: 2 Frequency Directional Comparison Relaying . . . . .	2-8
2-5 Channel: FSK, function: 3 Frequency, Directional Comparison Relaying . . . . .	2-8
2-6 Channel: FSK, Function: 2 Frequency Phase Comparison Relaying . . . . .	2-9
2-7 Channel FSK, function: 2 Frequency Directional Comparison Relaying, Shift up to Trip . . . . .	2-9
2-8a Channel: FSK, Function: 4 Frequency Directional Comparison Relaying . . . . .	2-10
2-8b of Frequency Definitions for 4 Frequency Function . . . . .	2-10
2-9 Backplane Jumpers . . . . .	2-16
2-10 Power Supply Module Jumpers . . . . .	2-16
2-11 Input/Output Module Jumpers . . . . .	2-16
2-12 Terminal Block Input Connections . . . . .	2-17
2-13 Terminal Block Output Connections . . . . .	2-17
2-14 Frequency Spacing . . . . .	2-18
2-15 Nominal Receiver Bandwidths . . . . .	2-18
2-16 Environmental Specifications . . . . .	2-19
2-17 Power Requirements . . . . .	2-19
2-18 Weight and Dimension Specifications . . . . .	2-19
2-19 System Frequencies . . . . .	2-20
3-1 Operation of the Directional Comparison Unblocking Scheme . . . . .	3-6
3-2 Operation of the Underreaching Transfer Trip Scheme . . . . .	3-6
3-3 Hybrid Options . . . . .	3-22
3-4 Directional Comparison Schemes for External and Internal Faults . . . . .	3-33
4-1 Recommended Test Equipment . . . . .	4-1
7-1 Primary/Fallback Communications Options . . . . .	7-8
7-2 Network Troubleshooting . . . . .	7-10
8-1 UPLC Inputs – DNP Points for ON-OFF Mode . . . . .	8-3
8-2 UPLC Inputs – DNP Points for FSK Mode . . . . .	8-4
8-3 UPLC Outputs – DNP Points for FSK Mode . . . . .	8-5
8-4 DNP Binary Outputs – UPLC Outputs for ON-OFF Mode . . . . .	8-6
8-5 UPLC Analog Values (All Modes) . . . . .	8-7

# Chapter 1. Ordering Information

## Ordering Information

The UPLC™ carrier is functionally compatible with earlier type carrier equipment (e.g., KR, TC, TC-10, TC-10A & TC-10B, TCF, TCF-10, TCF-10B). That is, you may use the UPLC™ with these other carrier types at the opposite end of the line.

You may use the UPLC™ carrier set with the following types of relay systems:

- All Directional-Comparison Systems
- Phase-Comparison Systems
- Direct Transfer Trip Systems

Options include:

- Automatic Checkback Testing Facilities for periodic testing of the carrier channel at programmable intervals (in ON-OFF mode)
- Trip Test Facility (in FSK mode)

The equipment identification number (catalog number) is displayed when you press “set” & is shown on all of the webpages. The UPLC™ catalog number comprises eleven (11) characters, each in a specific position. This number identifies the unit’s technical characteristics and capabilities, as well as any optional modules installed in the unit.

The table on the following page provides a complete listing of the options for ordering a UPLC™, as well as a sample catalog number. To order one or more UPLC™ units, simply identify the features you want for each chassis. For example, — U S 1 N S C 1 A N S X — describes a UPLC™ with the following features:

**Chassis:** UPLC™

**Configuration:** Single Transceiver Unit

**DC/DC Converter Power Supply:** 110/125/250 Vdc

**Redundant DC/DC Converter Power Supply:** None

**Outputs / Logic:** Standard Outputs (7 Solid State & 3 Contacts) / No Special Logic

**Ethernet Ports:** 10/100 Base T / Redundant 10/100 Base T (with RJ-45 Connector)

**Protocols / PC Interface (Front Port):** No Protocol / RS-232 Front Port

**Testing Facilities:** Single Transceiver

**Power Amp Features:** Standard Power Amp

**Backplate Option:** Standard

Table 1–1. UPLC™ Catalog Numbers.

	1	2	3	4	5	6	7	8	9	10	11
Typical Catalog Number	U	S	1	N	S	C	1	A	N	S	X
<b>Configuration</b>											
Single Transceiver Unit (3RU)		S									
Single Transceiver Unit (3RU) w/Dual Power Amplifier <sup>1</sup>		A									
Single Receiver Unit (3RU)		R									
Dual Transceiver Unit (4RU) w/Dual Power Amplifier <sup>1,2</sup>		D									
Dual Receiver Unit (4RU) <sup>2</sup>		Q									
<b>DC/DC Converter Power Supply</b>											
48/60 Vdc		4									
110/125/250 Vdc		1									
48/60 Vdc w/Auxiliary Power Supply for 20/200mA Output		8									
110/125/250 Vdc w/Auxiliary Power Supply for 20/200mA Output		2									
<b>Redundant DC/DC Converter Power Supply</b>											
48/60 Vdc		4									
110/125/250 Vdc		1									
48/60 Vdc w/Auxiliary Power Supply for 20/200mA Output		8									
110/125/250 Vdc w/Auxiliary Power Supply for 20/200mA Output		2									
None		N									
<b>Outputs / Logic</b>											
Std Outputs (7 SS, 3 Contacts) only		S									
Std Outputs (7 SS, 3 Contacts) + Trip Duty Contact Outputs, (4 per unit)		E									
Std Outputs (7 SS, 3 Contacts) / with 4 Frequency Logic		T									
Std Outputs (7 SS, 3 Contacts) + Trip Duty Contact Outputs / w/4 Freq. Logic		F									
<b>Ethernet Ports</b>											
None		A									
10/100 BaseT, Redundant 10/100 BaseT		C									
100 BaseFX, Redundant 100 BaseFX w/SC Connectors		D									
100 BaseFX, Redundant 100 BaseFX w/ST Connectors		E									
100 BaseFX, Redundant 100 BaseFX w/LC Connectors <sup>2</sup>		F									
100 BaseFX, Redundant 100 BaseFX w/MTRJ Connectors <sup>2</sup>		G									
10/100 BaseT and 100 BaseFX w/ST Connectors		H									
10/100 BaseT and 100 BaseFX w/SC Connectors		J									
10/100 BaseT and 100 BaseFX w/LC Connectors <sup>2</sup>		K									
10/100 BaseT and 100 BaseFX w/MTRJ Connectors <sup>2</sup>		L									
<b>Protocol / PC Interface (Front Port)</b>											
No Protocol / RS-232 Front Port		1									
No Protocol / USB Front Port		2									
IEC 61850 Compliant <sup>3</sup> / RS-232 Front Port		3									
IEC 61850 Compliant <sup>3</sup> / USB Front Port		4									
DNP Compliant / RS-232 Front Port		5									
DNP Compliant / USB Front Port		6									
<b>Testing Facilities (ON-OFF Checkback Test / FSK Trip Test)</b>											
Single Transceiver		A									
Dual Transceiver <sup>2</sup>		C									
None		N									
<b>Power Amp Features</b>											
Standard Power Amp / No Features		N									
Improved Power Amp		A									
Improved Power Amp with Frequency Selectivity for Reflected Power <sup>2</sup>		F									
<b>Back Plate Option</b>											
Standard (plain)		S									
<b>Future</b>											
Reserved for Future Options		X									

<sup>1</sup>Any Dual Configuration requires 2<sup>nd</sup> Power Supply <sup>2</sup>Not available at this time <sup>3</sup>Must Also Select an Ethernet Option



# Chapter 2. Product Description

## 2.1 Standard Nomenclature

The standard nomenclature for AMETEK carrier protection equipment is as follows:

**Cabinet** – contains fixed-racks, swing-racks, or open racks

**Rack** – contains one or more chassis (e.g., the UPLC™)

**Chassis** – contains several printed circuit boards, called modules (e.g., Transmitter or Receiver)

**Module** – contains a number of functional circuits (e.g., Oscillator or Synthesizer)

**Circuit** – a complete function on a printed circuit board

## 2.2 UPLC™ Chassis

The Front Panel is shown in Figure 2–1. See Figure 2–2 for the backplane.

The UPLC™ chassis specifications (see Figure 2–3) include standard dimensions of:

Single: Height – 5.25” (133.35 mm), requiring 3 rack units, each measuring 1.75” (44.45 mm)

Width – 19.00” (482.6 mm) Depth – 13.50” (342.9 mm)

Double: Height – 7.00” (266.70 mm), requiring 4 rack units, each measuring 1.75” (44.45 mm)

Width – 19.00” (482.6 mm) Depth – 13.50” (342.9 mm)

Each chassis is notched for mounting in a standard 19” relay rack.

## 2.3 UPLC™ Modules

The basic UPLC™ has 7 printed circuit boards in a 3RU 19 inch chassis. There are 4 additional boards that may be supplied, based upon the catalog number purchased. These modules are:

Power Supply (Main)

Power Supply (Redundant) Optional

Power Amplifier (Main)

Power Amplifier (Redundant) Optional

Display Board

Aux. Display board – with either USB or DB9 connector

Input/Output Board – optional 4-trip duty outputs available

Transceiver Board

Ethernet Board – optional

Aux. Power Supply Board – optional for powering 5V, 20V, 20 or 200 mA outputs

Motherboard

The block diagram, illustrating how these are all interconnected is at the end of this chapter.

Figure 2-1. Front Panel (with DB9 & USB).

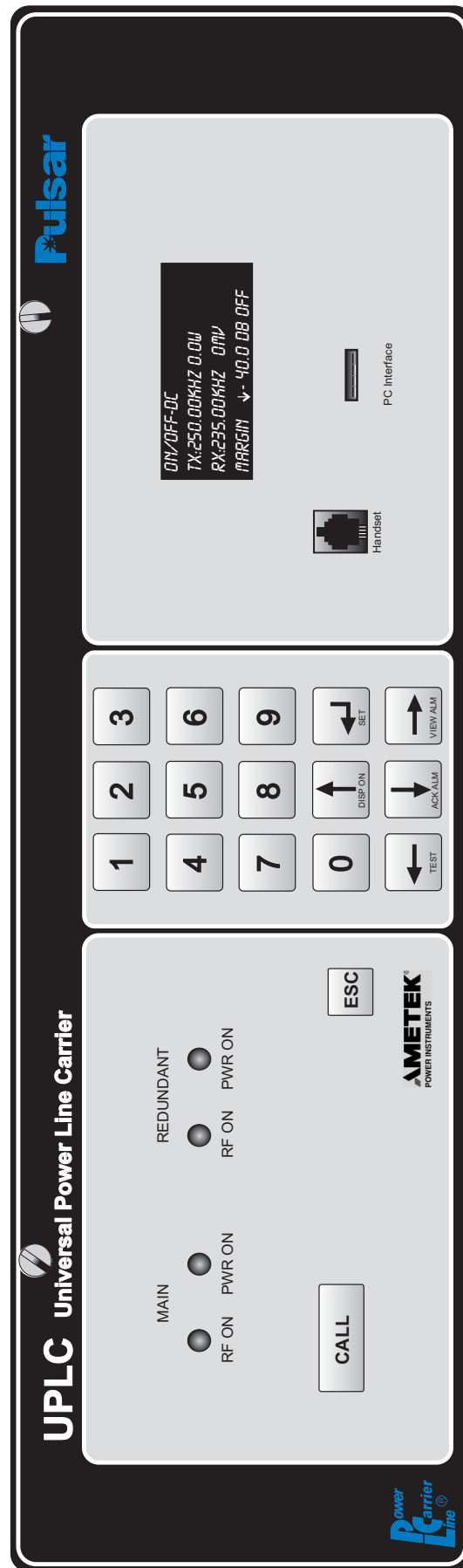
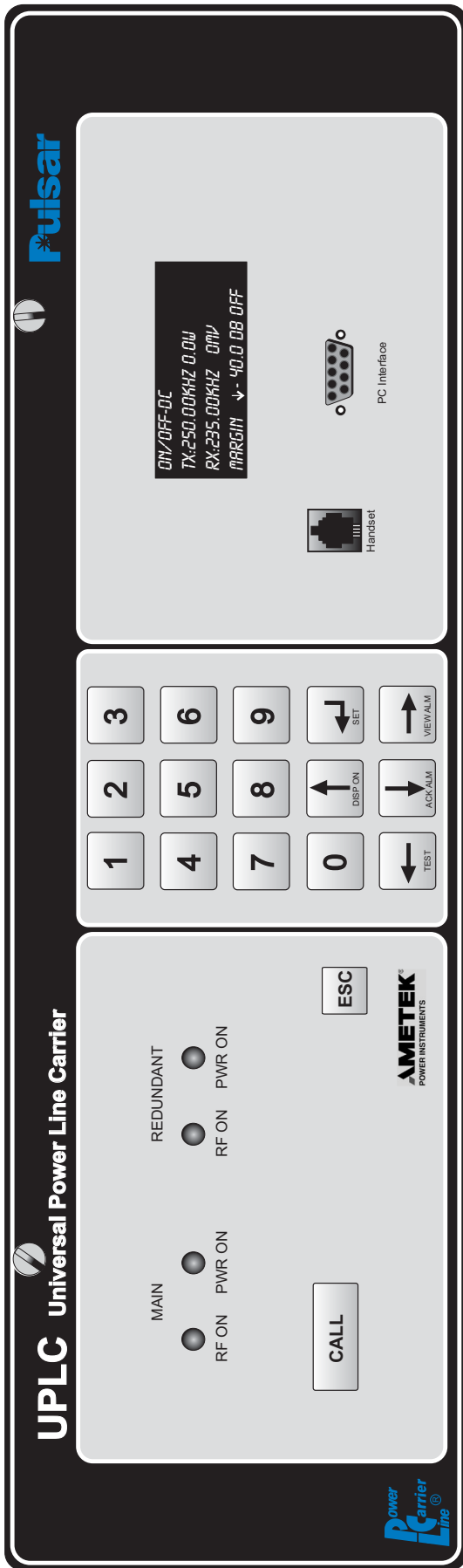

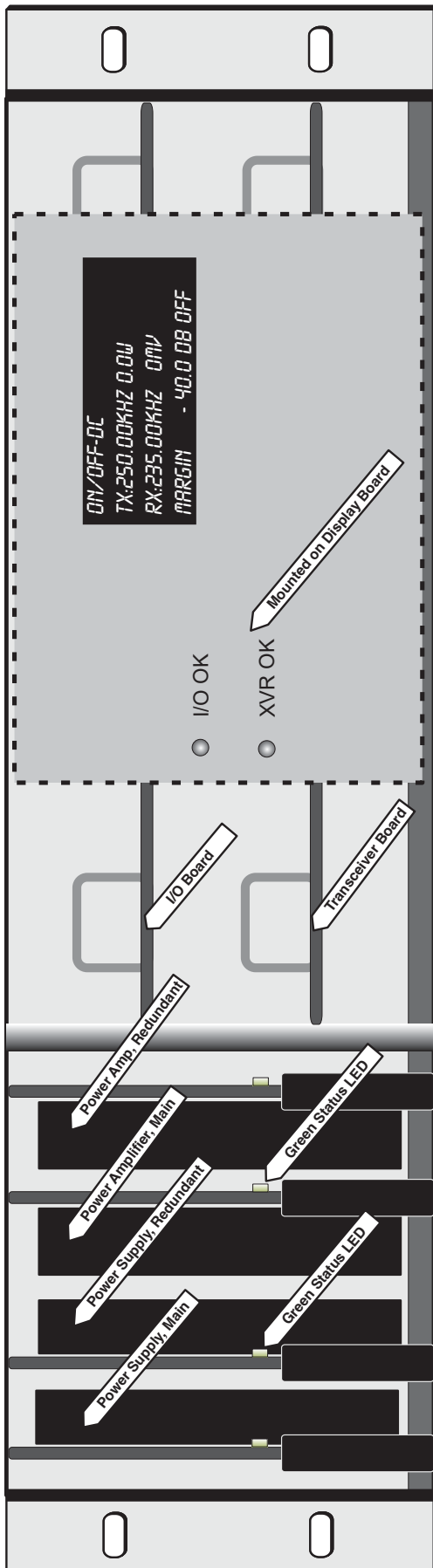

**(FRONT VIEW)**  
NOTE: Ethernet board mounted on rear of transceiver board.

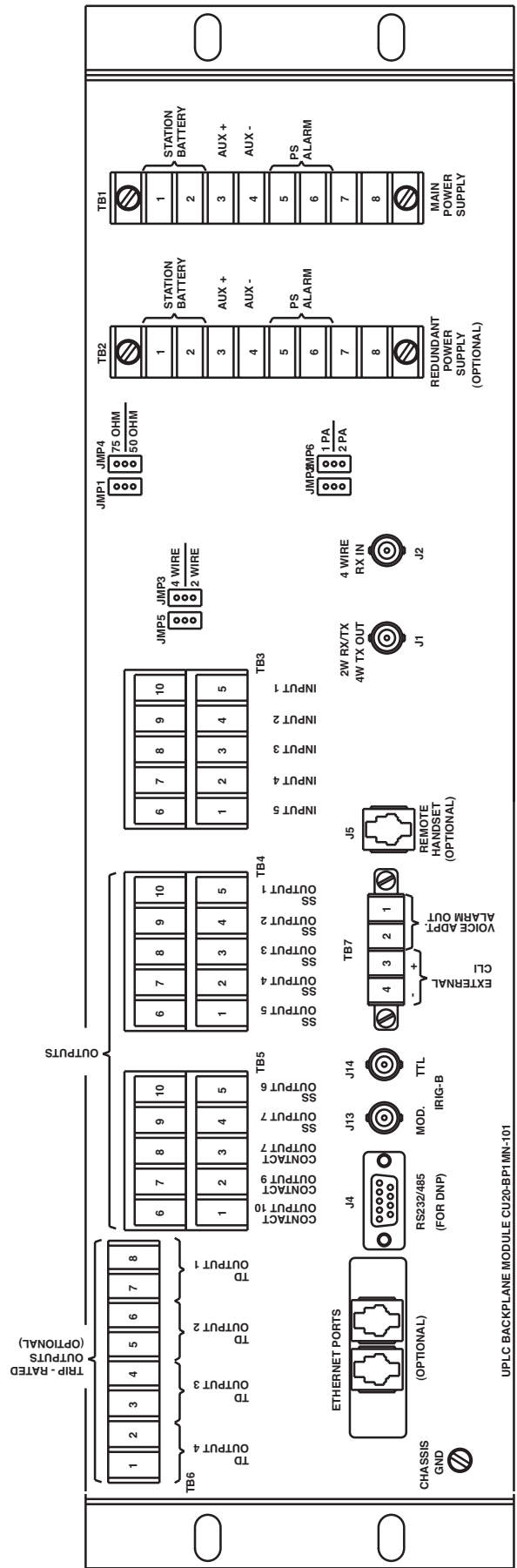
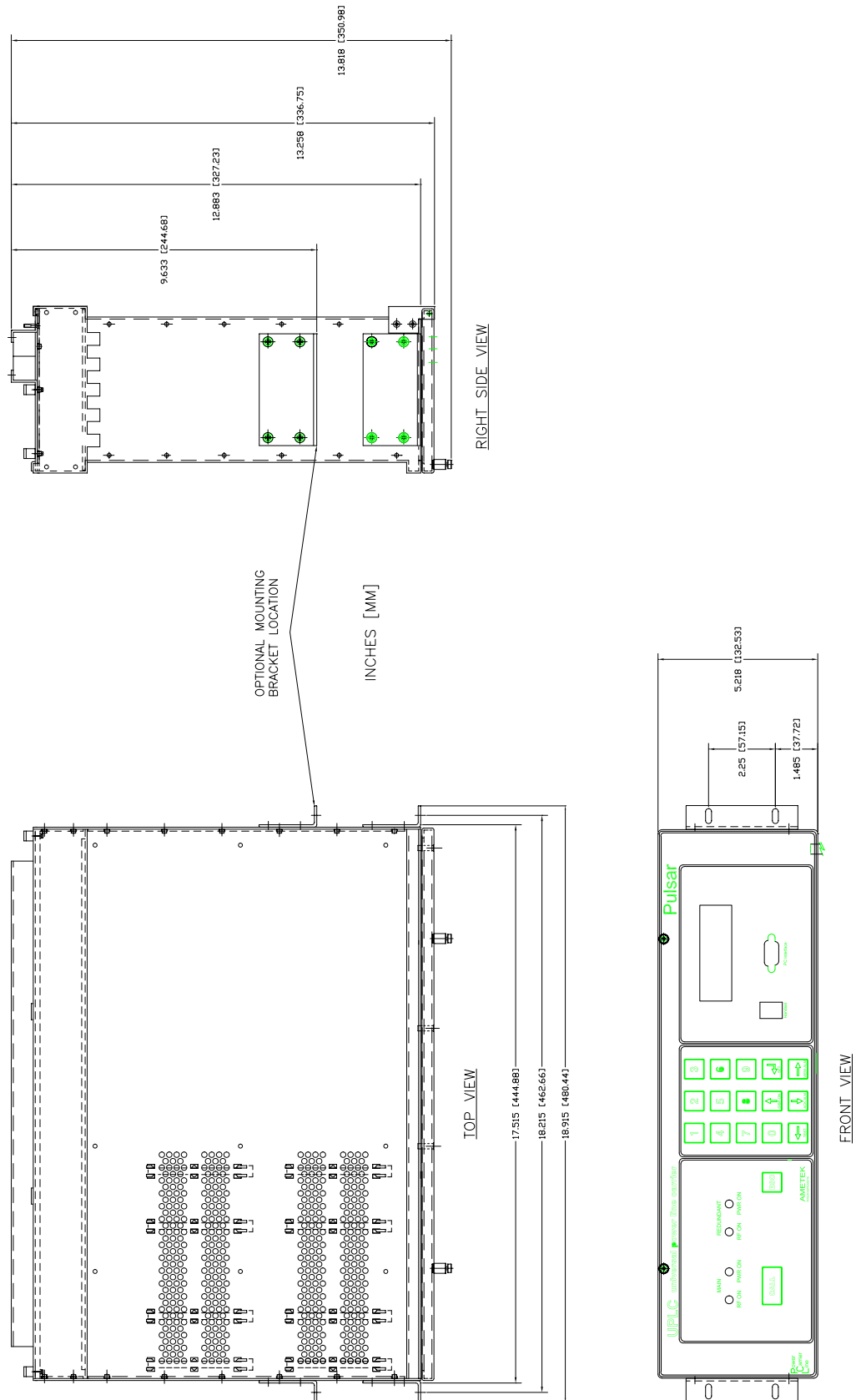

Figure 2-2. Chassis.

Figure 2-3. Chassis Dimensions.



## 2.4 UPLC™ Functional Description.

The UPLC™ has a transmitter section and a receiver section on the transceiver board. If the unit is purchased as a receive-only system, then only the receiver logic and associated information applies. The block diagram, (Figure 2–4), at the end of this chapter, illustrates the interconnection of the UPLC™ hardware.

The transmitter is made up of the keying inputs (on the I/O board), the keying logic (in the digital signal processing (DSP) firmware on the transceiver board) the power amplifier(s) board and the RF interface (on the motherboard). The state of the keying inputs will determine what output is produced, both frequency and RF power out. For example, an ON-OFF system will be turned on when the START input is asserted. The signal produced will be at the programmed frequency and at the high-level power output. In an FSK system, with no keying input asserted, the GUARD frequency is produced at the low-level power output. When one or more of the keying inputs are asserted, then the appropriate signal will be produced. The following keying tables describe the different combinations available.

The receiver is made up of the RF interface (on the motherboard), input filters and detect/discrimination and the logic described herein (in the DSP on the transceiver board), and the associated outputs (on the I/O board). The incoming RF signal is detected or discriminated according to the programming, and based on the signal received, produces the appropriate output. For ON-OFF systems, the outputs are simple – if the signal is detected (i.e. – the RF signal is the desired frequency and is above the minimum sensitivity), then the receiver output is produced. For FSK systems, it is more complicated and there are several logic choices available. The FSK logic diagrams at the end of this chapter describe the choices available.

Besides the main function of the UPLC™ as a power-line carrier channel, there are several other ancillary functions and optional features available.

The processor on the transceiver board handles many of the “housekeeping” functions. It handles

the web pages that are served up when connected to a personal computer (pc). The web pages allow you to set up user accounts, set the UPLC™, and download settings in either an XML file or a report file. The XML file is used for re-loading settings on a UPLC™. Upgrading the firmware is also done through the web pages. Calibration can also be done via the web pages.

The Sequence of Events (SOEs) reside in the processor on the transceiver board. These track events that occur in the UPLC™. They are viewed via the web pages and can be downloaded into a CSV (common separated values) file format. The I/O programming allows for up to three external events to be fed into the UPLC™ SOEs. For example, you can monitor the breaker auxiliary contact position in relationship to keying inputs or receiver outputs. SOEs are stored in non-volatile-random-access memory (NOVRAM) so that they are maintained even when the unit is powered down.

The settings files also reside in the processor on the transceiver board and are stored in NOVRAM. There are three sets of the file stored for redundancy purposes.

Status indication is provided by the four line by 20-character display on the front panel. The basic programming - Channel type, function, frequencies, RF output, receive level and margin are displayed. It also has a 15-button keypad that allows for minor setting changes, exercising of the PLC channel, calibration of the transmitter and receiver, and configuration of the Internet Protocol functions. The display turns off automatically 30 minutes after input from the user has stopped. To turn it back on requires pressing the DISP ON button or any other button on the keypad. There is also a front panel serial port (USB or DB9 connector) to connect a pc to allow settings, etc through web pages.

Also on the front panel are several blue indicator lights that indicate if the main and optional redundant power supplies and power amplifiers are on.

Additionally, on the front panel are controls for an optional voice feature (not available at this time)

that includes a plug for a handset and a call button to initiate the call. An audible alarm is also on the front panel display board.

Each printed circuit board that comprises the UPLC™ has a green status LED associated with it. The power supplies and power amplifiers have an LED on the front edge of the printed circuit board that is visible with the front cover down. The Transceiver and Input/Output board have LEDs that are located on the front panel display board, visible with the front cover down. The Ethernet board has green and yellow indicating lights visible from the rear of the unit. If any of these lights are not illuminated, it indicates a problem with that board. There are also 4-character alarm indications on the front panel display. For these alarm indications, please refer to the installation manual supplied with the unit.

In addition to the standard testing from the front panel, there is also available as a purchased option, integrated testing facilities. When used as an ON-OFF PLC, the channel status is not known until called upon to perform its operation, so therefore could have failed without warning. The UPLC™ has an option for performing automatic checkback tests. Please see the installation guide for details. When used as an FSK, sometimes it is desired to perform a “shift to trip” test from end to end. The trip test feature is available when purchased. Please see chapter 8 for details.

Network protocols will also be available in the future to allow device-to-device communications. These include but may not be limited to DNP3.0 and IEC61850. Please contact the factory for further details.

### 2.4.1 Keying Logic

Depending upon the channel type and function set, different keying logic is selected. Following are tables, which describe the functionality of the keying logic for each channel type and function combination.

#### ON OFF Channels

ON-OFF channels typically are not keyed normally and are keyed on to block tripping for an external fault. A choice is made to give priority to either the stop input or the start input should they both be present at the same time. Typical Directional Comparison and Phase Comparison relaying systems utilize a stop priority; giving the relay system the ability to trip over not trip, thereby making the system dependable.

Table 2–1 applies to the majority of modern relay systems in service that use the ON-OFF type of PLC channels.

Some unusual systems may require that start has priority. For these systems, Table 2–2 would apply.

Table 2–1. Channel Type: On-Off, function: Directional or Phase Comparison Relaying with Stop Priority

START	STOP	LL KEY	TRANS. OUTPUT CONDITION FOR THIS KEYING INPUT STATE
Not Activated	Not Activated	Not Activated	Transmitter off
Not Activated	Not Activated	Activated	Send Low Output Power
Not Activated	Activated	Not Activated	Transmitter off
Not Activated	Activated	Activated	Transmitter off
Activated	Not Activated	Not Activated	Send High Output Power
Activated	Not Activated	Activated	Send High Output Power
Activated	Activated	Not Activated	Transmitter off
Activated	Activated	Activated	Transmitter off

Table 2–2. Channel Type: On-Off, function: Directional or Phase Comparison Relaying with Start Priority.

START	STOP	LL KEY	TRANS. OUTPUT CONDITION FOR THIS KEYING INPUT STATE
Not Activated	Not Activated	Not Activated	Transmitter off
Not Activated	Not Activated	Activated	Send Low Output Power
Not Activated	Activated	Not Activated	Transmitter off
Not Activated	Activated	Activated	Transmitter off
Activated	Not Activated	Not Activated	Send High Output Power
Activated	Not Activated	Activated	Send High Output Power
Activated	Activated	Not Activated	Send High Output Power
Activated	Activated	Activated	Send High Output Power

2

Table 2–3. Channel: On-Off, function: Directional Comparison Relaying with KA-4 type Relaying System.

START	STOP	KEY	CB TX	TRANS. OUTPUT CONDITION FOR THIS KEYING INPUT STATE
Not Activated	Not Activated	Not Activated	Not Activated	Input States not Likely to Exist
Not Activated	Not Activated	Not Activated	Activated	Input States not Likely to Exist
Not Activated	Not Activated	Activated	Not Activated	Input States not Likely to Exist
Not Activated	Not Activated	Activated	Activated	Input States not Likely to Exist
Not Activated	Activated	Not Activated	Not Activated	Trans. Off, CB Not Allowed
Not Activated	Activated	Not Activated	Activated	Trans. Off, CB Not Allowed
Not Activated	Activated	Activated	Not Activated	Trans. Off, CB Not Allowed
Not Activated	Activated	Activated	Activated	Trans. Off, CB Not Allowed
Activated	Not Activated	Not Activated	Not Activated	Send High Output Power, CB Not Allowed
Activated	Not Activated	Not Activated	Activated	Send High Output Power, CB Not Allowed
Activated	Not Activated	Activated	Not Activated	Send High Output Power, CB Not Allowed
Activated	Not Activated	Activated	Activated	Send High Output Power, CB Not Allowed
Activated	Activated	Not Activated	Not Activated	Transmitter Off
Activated	Activated	Not Activated	Activated	Transmitter Off, CB Allowed
Activated	Activated	Activated	Not Activated	Send Low Level Output, CB Not Allowed
Activated	Activated	Activated	Activated	Send Low Level Output, CB Not Allowed

Table 2–4. Channel: FSK, function: 2 Frequency Directional Comparison Relaying.

TRIP or UB Key	PWR OFF	52B	TRANS. OUTPUT CONDITION FOR THIS KEYING INPUT STATE
Not Activated	Not Activated	Not Activated	Send HF at Low Level Output
Not Activated	Not Activated	Activated	Send HF at High Level Output
Not Activated	Activated	Not Activated	Transmitter Output Power off
Not Activated	Activated	Activated	Transmitter Output Power off
Activated	Not Activated	Not Activated	Send LF at High Level Output
Activated	Not Activated	Activated	Send LF at High Level Output
Activated	Activated	Not Activated	Transmitter Output Power Off
Activated	Activated	Activated	Transmitter Output Power Off

Table 2–5. Channel: FSK, function: 3 Frequency, Directional Comparison Relaying.

DTT KEY	LR KEY	PWR OFF	52B	TRANS. OUTPUT CONDITION FOR THIS KEYING INPUT STATE
Not Activated	Not Activated	Not Activated	Not Activated	Send CF at Low Power Output
Not Activated	Not Activated	Not Activated	Activated	Send CF at High Power Output
Not Activated	Not Activated	Activated	Not Activated	Transmitter Output Power Off
Not Activated	Not Activated	Activated	Activated	Transmitter Output Power Off
Not Activated	Activated	Not Activated	Not Activated	Send HF at High Power Output
Not Activated	Activated	Not Activated	Activated	Send HF at High Power Output
Not Activated	Activated	Activated	Not Activated	Transmitter Output Power Off
Not Activated	Activated	Activated	Activated	Transmitter Output Power Off
Activated	Not Activated	Not Activated	Not Activated	Send LF at High Power Output
Activated	Not Activated	Not Activated	Activated	Send LF at High Power Output
Activated	Not Activated	Activated	Not Activated	Transmitter Output Power Off
Activated	Not Activated	Activated	Activated	Transmitter Output Power Off
Activated	Activated	Not Activated	Not Activated	Send LF at High Power Output
Activated	Activated	Not Activated	Activated	Send LF at High Power Output
Activated	Activated	Activated	Not Activated	Transmitter Output Power Off
Activated	Activated	Activated	Activated	Transmitter Output Power Off



Relay Systems that use the older-style electro-mechanical relays such as ABB/Westinghouse’s KA-4/KD-10 series of relays that have one lead that serves the function of both start and stop. Table 2–3 would apply in this situation. Please see the Installation Guide for details on how to install this type of system. The “common start/stop input” box must be checked in order for this table to be applied. FSK channel functions are used for Direct Transfer Tripping Systems or Line Relay Systems.

If the DTT/POTT or the Unblocking-2 F selection is set for the function, then Table 2–4 will apply. When the FSK channel is used for both a DTT and Line relaying channel, Table 2–5 will apply. If both the DTT Key and LR key are present, the DTT key will have precedence. In using the FSK channel for Phase Comparison Relaying systems, Table 2–6 will apply.

Table 2–6. Channel: FSK, Function: 2 Frequency Phase Comparison Relaying.

PC Key	PWR OFF	POWER BOOST	TRANS. OUTPUT CONDITION FOR THIS KEYING INPUT STATE
Not Activated	Not Activated	Not Activated	Send HF at Low Power Output
Not Activated	Not Activated	Activated	Send HF at High Power Output
Not Activated	Activated	Not Activated	Transmitter Output Power off
Not Activated	Activated	Activated	Transmitter Output Power off
Activated	Not Activated	Not Activated	Send LF at Low Power Output
Activated	Not Activated	Activated	Send LF at High Power Output
Activated	Activated	Not Activated	Transmitter Output Power Off
Activated	Activated	Activated	Transmitter Output Power Off

Table 2–7. Channel FSK, function 2 Frequency Directional Comparison Relaying, Shift up to Trip.

TRIP or UB Key	PWR OFF	52B	TRANS. OUTPUT CONDITION FOR THIS KEYING INPUT STATE
Not Activated	Not Activated	Not Activated	Send LF at Low Level Output
Not Activated	Not Activated	Activated	Send LF at High Level Output
Not Activated	Activated	Not Activated	Transmitter Output Power off
Not Activated	Activated	Activated	Transmitter Output Power off
Activated	Not Activated	Not Activated	Send HF at High Level Output
Activated	Not Activated	Activated	Send HF at High Level Output
Activated	Activated	Not Activated	Transmitter Output Power Off
Activated	Activated	Activated	Transmitter Output Power Off

Table 2–8a. Channel: FSK, Function: 4 Frequency Directional Comparison Relaying.

DTT KEY	LR KEY	PWR OFF	POWER BOOST/52B	TRANS. OUTPUT CONDITION FOR THIS KEYING INPUT STATE
Not Activated	Not Activated	Not Activated	Not Activated	Send F3 at Low Level Output
Not Activated	Not Activated	Not Activated	Activated	Send F3 at Low Level Output
Not Activated	Not Activated	Activated	Not Activated	Transmitter Output Power Off
Not Activated	Not Activated	Activated	Activated	Transmitter Output Power Off
Not Activated	Activated	Not Activated	Not Activated	Send F2 at High Level Output
Not Activated	Activated	Not Activated	Activated	Send F2 at High Level Output
Not Activated	Activated	Activated	Not Activated	Transmitter Output Power Off
Not Activated	Activated	Activated	Activated	Transmitter Output Power Off
Activated	Not Activated	Not Activated	Not Activated	Send F4 at High Level Output
Activated	Not Activated	Not Activated	Activated	Send F4 at High Level Output
Activated	Not Activated	Activated	Not Activated	Transmitter Output Power Off
Activated	Not Activated	Activated	Activated	Transmitter Output Power Off
Activated	Activated	Not Activated	Not Activated	Send F1 at High Level Output
Activated	Activated	Not Activated	Activated	Send F1 at High Level Output
Activated	Activated	Activated	Not Activated	Transmitter Output Power Off
Activated	Activated	Activated	Activated	Transmitter Output Power Off

Table 2–8b. of Frequency Definitions for 4 Frequency Function

GENERAL FUNCTION	FREQUENCY ID	FREQUENCY RELATIVE TO CENTER FREQUENCY	
		+/- 250Hz SHIFT	+/- 500Hz SHIFT
CMD A & B	F1	249Hz below Center Freq.	498Hz below Center Freq.
CMD B	F2	83Hz below Center Freq.	166Hz below Center Freq.
GUARD	F3	83Hz above Center Freq.	166Hz above Center Freq.
CMD A	F4	249Hz above Center Freq.	498Hz above Center Freq.

## 2.4.2 FSK Receiver Logic

### 2-Frequency Directional Comparison Logic

Figure 2–5 illustrates this logic. The logic can be configured for a typical Direct Transfer Trip or Directional Comparison Unblock System. To provide the utmost security, this logic provides for 120ms of guard before trip logic. It requires that after loss of signal, there must be at least 120ms of guard before the system is allowed to trip. This may be disabled or overridden according to system requirements. Details follow. There is also a 120ms trip after guard requirement that requires within 120 ms of losing guard that trip is received, otherwise the channel locks out from tripping.

Hold timers are available for both the trip and guard outputs that can be set from 1 to 100 ms in 1 ms increment or be disabled (0 ms). These timers are on the output side of the logic and therefore only affect the solid state or electromechanical outputs. They have no affect on the functionality of the internal logic. The pre-trip timer allows for higher security by delaying the trip output by the time set. It is settable from 0 to 30 ms in 1 ms increments. Unblock functions will typically be 4 to 8 ms but DTT functions will typically be on the order of 20 or 30 ms.

The logic also provides for line protection of the transmission line when the remote end’s breaker is open. Upon receiving a trip signal from the other end for longer than 1000 ms, indicating an open breaker, the logic disables the guard before trip requirement such that if the channel is lost and returns in the trip state, the line relay system will be allowed to trip for a fault. To allow for this scenario, the guard before trip should be set for “override”. After guard is restored, the logic is reset after 200 ms. Typical line relaying or DTT systems do not disable guard before trip logic. Unblock logic is provided in the UPLC™ logic to force a trip on loss of channel. If a fault causes a loss of channel, there is a window setting between 1 and 500 ms that will produce a trip output. A setting of 0 ms will disable this feature. After this time, the channel is locked out from tripping until it receives 120ms of guard. The assertion of the trip output for unblock can be

delayed by 1 to 100 ms if desired, with a setting of 0 ms disabling this delay. Typical permissive over-reaching transfer trip systems over Power-Line Carrier take advantage of the Unblock Logic and are Directional Comparison Unblock systems. A checkback trip output is provided for testing purposes. The checkback trip will always assert anytime a trip is asserted by the logic. However, if a trip frequency is received after a loss of channel (without guard return), then only a checkback trip is asserted.

### 3-Frequency Directional Comparison Logic

Figure 2–6 illustrates this logic. This logic is similar to the 2-frequency logic except with the addition of logic to handle the Direct Transfer Trip logic separately, in addition to providing for a Directional Comparison Unblock System. The Guard Before Trip and Trip After Guard Logic are duplicated for the DTT portion as well as the Trip hold and Guard hold timers. Note that when the 3-frequency system goes to an Unblock trip, the DTT Guard does not drop out but the Unblock Guard does. Likewise, on a DTT Trip, the Unblock Guard does not dropout but the DTT Guard does.

### 4-Frequency Directional Comparison Logic

Figure 2–7 illustrates this logic. This logic is like having two independent sets of the 2-Frequency logic. In the 2-Frequency logic there are two inputs to the logic, Guard and Trip. In the 4-Frequency logic, there are four inputs (frequencies) to the logic, Guard (F3), CMD A Trip (F4), CMD B Trip (F2), and CMD A&B Trip (F1). Like in the 3-Frequency logic, a receipt of CMD A Trip does not cause the guard for the CMD B to drop out.

Functional block diagrams for these configurations can be found at the end of this chapter.

## Timers

Following are explanations of all the timers available on the UPLC™. Those not available on certain functions are so noted.

### Pre-Trip Timer

The Pre-Trip Timer does not allow tripping until the trip signal has been present for the time set. This timer is settable from 0 to 30 ms in 1ms increments. A typical application of this timer in Direct Transfer Trip systems is to set it for the maximum delay possible, 20 to 30 ms. Limitations on the critical clearing time of the power system will have a direct impact on this setting. In Directional Comparison/POTT systems, we recommend a setting of 4 to 8 ms.

### Trip Hold Timer

The Trip Hold Timer lets you stretch the trip output. You can set it for 0 to 100 ms or disable (0 ms) it. We recommend that you use the disabled setting in the Unblock/POTT to avoid problems with transient blocking.

### Guard Hold Timer

The Guard Hold Timer stretches the guard output by the amount you set. You can set it for 1 to 100ms or disable (0ms) it. The disabled setting is appropriate for most applications.

### Unblock Timer (not available on 2 Frequency DTT/POTT)

The Unblock Timer provides a trip output for the time set on loss of channel, which is defined as low level and loss of guard. You can set it for 1 to 500ms in 1 ms increment with 0 ms disabling the feature.

The normal setting is 150ms in the Unblock system and disabled for all other applications. This is what differentiates the Unblock system from the POTT.

### Guard before Trip

With this function set to “on without override”, the logic requires guard to be received for 120 ms before the system is allowed to trip. With it set to “on with override”, the 120 ms guard return is required except where trip has been received for over 1,000 ms; if there is a loss of channel, then the guard is not required prior to tripping. Typically, you would use this where open breaker keying is required.

### Unblock Delay Timer (not available on 2 Frequency DTT/POTT)

The Unblock Delay Timer delays the Unblock timer from initiating a trip output on loss of channel; it also delays the low level output. You can set it from 1 to 100 ms or disable it (0 ms).

## 2.5 Jumpers

An explanation of jumper positions is provided here. However, for more detailed information such as location, please refer to the UPLC™ Installation Guide that you received with the unit.

### 2.5.1 Backplane (Rear Panel)

JMP 1/4 – 50 or 75W - Used to select transmitter impedance

JMP 3/5 – 2 or 4 wire - Sets RF coax connection

If set to 2-wire, then the transmitter and receiver are on a common coax (J1), as in most ON/OFF applications. If set to 4-wire, then the transmitter outputs on coax connector J1 and the receiver input is on coax connector J2, as in all FSK applications and a few ON/OFF applications.

JMP 2/6/7 – 1 or 2 Power Amplifiers. Set according to the number of power amplifiers present.

### 2.5.2 I/O Module

<p>INPUT 1 INPUT 2 INPUT 3 INPUT 4 INPUT 5</p>	}	<p>15V, 48V, 125V or 250V - set according to driving voltage for the given input. If the input is not used, it is recommended that the jumper be set for 250V.</p>
--	---	--

<p>LL01 LL02 LL03 LL04 LL05 LL06 LL07</p>	}	<p>1.0A/0.1A - set according to load level. Microprocessor relay inputs should be set for 0.1A. Greater loads should use the 1.0A setting such as modern lockout relays.</p>
---	---	--

<p>LL08 LL09 LL10</p>	}	<p>NO/NC - low level contact outputs set according to desired position when relay coil is de-energized. When not energized, the contact will be NO (Normally Open) or NC (Normally Closed).</p>
-------------------------------	---	---

<p>TD01 TD02 TD03 TD04</p>	}	<p>NO/NC - Trip Duty contact outputs set according to desired position when relay coil is de-energized. When not energized the contact will be NO (Normally Open) or NC (Normally Closed).</p>
--	---	--

### 2.5.3 Power Supply Module

JMP1/JMP2 – NO/NC - Selects the contact position when the relay coil is de-energized. This relay coil is fail-safe and normally energized when the power supply is functional. Therefore set the contact to NO if you want the contact to open for alarm or NC if you want the contact to close for alarm.

JMP3 – PWR ON/PWR OFF - allows de-energizing the module and re-inserting it into the chassis.

### 2.5.4 Aux. Power Supply Module

JMP1/JMP2 – (46V/20V/20mA or 8V/200mA) - allows you to select either a 20mA or 200mA capable output for use with carrier auxiliary relays such as KA-4 (ABB relay).

JMP3 – (46V/20V) - if JMP1/2 is in the (46V/20V) position, this allows selection between the 46V or 20V option. The 46V option is used for 20mA carrier auxiliary relays such as KA-4 (ABB relay). The 20V option is used for solid state relay systems such as ABB's STU or SKAU relay systems.

**Jumper Settings Worksheet**

**2**

<b>Module</b>	<b>Jumper</b>	<b>Setting</b>				
<b>Backplane</b>	JMP1/4	<input type="checkbox"/> 50Ω	<input type="checkbox"/> 75Ω			
	JMP3/5	<input type="checkbox"/> 2-wire	<input type="checkbox"/> 4-wire			
	JMP2/6/7	<input type="checkbox"/> 1-PA	<input type="checkbox"/> 2-PA			
<b>I/O Module</b>	INPUT 1	<input type="checkbox"/> 15V	<input type="checkbox"/> 48V	<input type="checkbox"/> 125V	<input type="checkbox"/> 250V	
	INPUT 2	<input type="checkbox"/> 15V	<input type="checkbox"/> 48V	<input type="checkbox"/> 125V	<input type="checkbox"/> 250V	
	INPUT 3	<input type="checkbox"/> 15V	<input type="checkbox"/> 48V	<input type="checkbox"/> 125V	<input type="checkbox"/> 250V	
	INPUT 4	<input type="checkbox"/> 15V	<input type="checkbox"/> 48V	<input type="checkbox"/> 125V	<input type="checkbox"/> 250V	
	INPUT 5	<input type="checkbox"/> 15V	<input type="checkbox"/> 48V	<input type="checkbox"/> 125V	<input type="checkbox"/> 250V	
	LL01	<input type="checkbox"/> 0.1A	<input type="checkbox"/> 1.0A			
	LL02	<input type="checkbox"/> 0.1A	<input type="checkbox"/> 1.0A			
	LL03	<input type="checkbox"/> 0.1A	<input type="checkbox"/> 1.0A			
	LL04	<input type="checkbox"/> 0.1A	<input type="checkbox"/> 1.0A			
	LL05	<input type="checkbox"/> 0.1A	<input type="checkbox"/> 1.0A			
	LL06	<input type="checkbox"/> 0.1A	<input type="checkbox"/> 1.0A			
	LL07	<input type="checkbox"/> 0.1A	<input type="checkbox"/> 1.0A			
	LL08	<input type="checkbox"/> NO	<input type="checkbox"/> NC			
	LL09	<input type="checkbox"/> NO	<input type="checkbox"/> NC			
	LL10	<input type="checkbox"/> NO	<input type="checkbox"/> NC			
	optional	TD01	<input type="checkbox"/> NO	<input type="checkbox"/> NC		
	optional	TD02	<input type="checkbox"/> NO	<input type="checkbox"/> NC		
	optional	TD03	<input type="checkbox"/> NO	<input type="checkbox"/> NC		
	optional	TD04	<input type="checkbox"/> NO	<input type="checkbox"/> NC		
	<b>Power Supply</b>	JMP1/2	<input type="checkbox"/> NO	<input type="checkbox"/> NC	(PS Alarm Contact)	
JMP3		<input type="checkbox"/> PWR ON	<input type="checkbox"/> PWR OFF			
<b>Aux. Power Supply</b> optional	JMP1/2	<input type="checkbox"/> 46V/20mA/20V	<input type="checkbox"/> 8V/200mA	(For EM Relay		
	JMP3	<input type="checkbox"/> 46V/20mA	<input type="checkbox"/> 20V	Interface)		

Table 2–9 Backplane Jumpers.

Function	Selection	Label
Coax Settings	2 wire/4 wire	JMP3/JMP5
Single or Dual Power Amps	1 PA/2 PA	JMP2/JMP6
Coax Impedance	50Ω/75Ω	JMP1/JMP4

Table 2–10 Power Supply Module Jumpers.

Function	Selection	Label
Power ON/OFF Selection	PWR ON/PWR OFF	JMP3
Alarm	NO/NC	JMP1/JMP2

Table 2–11 Input/Output Module Jumpers.

Inputs	Selection	Jumpers
Input 1	15, 48, 125, 250V	INPUT 1
Input 2	15, 48, 125, 250V	INPUT 2
Input 3	15, 48, 125, 250V	INPUT 3
Input 4	15, 48, 125, 250V	INPUT 4
Input 5	15, 48, 125, 250V	INPUT 5

Outputs	Selections	Jumpers
Low Level Output 1	0.1/1.0A	LL01
Low Level Output 2	0.1/1.0A	LL02
Low Level Output 3	0.1/1.0A	LL03
Low Level Output 4	0.1/1.0A	LL04
Low Level Output 5	0.1/1.0A	LL05
Low Level Output 6	0.1/1.0A	LL06
Low Level Output 7	0.1/1.0A	LL07
Low Level Output 8	NO/NC	LL08
Low Level Output 9	NO/NC	LL09
Low Level Output 10	NO/NC	LL10
Trip Duty Output 1	NO/NC	TD01
Trip Duty Output 2	NO/NC	TD02
Trip Duty Output 3	NO/NC	TD03
Trip Duty Output 4	NO/NC	TD04



## 2.6 Input/Output Connections

All inputs and outputs are non-polarity sensitive, except for the Power Supply Auxiliary output & external CLI outputs.

Table 2–12 Terminal Block Input Connections.

Inputs	Terminal Block
Main Power Supply Input	TB1-1 & 2
Redundant Power Supply Input	TB2-1 & 2
Keying Input 1	TB3-5 & 10
Keying Input 2	TB3-4 & 9
Keying Input 3	TB3-3 & 8
Keying Input 4	TB3-2 & 7
Keying Input 5	TB3-1 & 6

2

Table 2–13 Terminal Block Output Connections.

LL Outputs- 1A Transistor	Terminal Block	LL Outputs- 0.25A Contact	Terminal Block
SS Output 1 (LL01)	TB4-5 & 10	EM Output 8 (LL08)	TB5-3 & 8
SS Output 2 (LL02)	TB4-4 & 9	EM Output 9 (LL09)	TB5-2 & 7
SS Output 3 (LL03)	TB4-3 & 8	EM Output 10 (LL10)	TB5-1 & 6
SS Output 4 (LL04)	TB4-2 & 7	<b>Optional Trip Duty Contacts</b>	
SS Output 5 (LL05)	TB4-1 & 6	EM Output 1 (TD01)	TB6-7 & 8
SS Output 6 (LL06)	TB5-5 & 10	EM Output 2 (TD02)	TB6-5 & 6
SS Output 7 (LL07)	TB5-4 & 9	EM Output 3 (TD03)	TB6-3 & 4
		EM Output 4 (TD04)	TB6-1 & 2
<b>Power Supply Alarms/Outputs</b>		<b>Other Outputs</b>	
Main PS*	TB1-5 & 6	External CLI**	TB7-3(+) & 4(-)
Redundant PS* (Opt.)	TB2-5 & 6	* Non-Polarity Sensitive **Polarity Sensitive	
Optional PS Aux.** for KA-4 relays	TB1-3 & 4 (+) (-)		
Optional Redundant** PS Aux. for KA-4 relay	TB2-3 & 4 (+) (-)		

## 2.7 Specifications

Table 2–14. Minimum Frequency Spacing.

<b>ON/OFF Applications</b>			
Wide Band	Directional Comparison Relaying		4000 Hz
Narrow Band	Directional Comparison Relaying		2000 Hz
Extreme Wide Band	Phase Comparison Relaying		4000 Hz
<b>FSK Applications</b>			
Narrow Band:	Directional Comparison or DTT	1 way	500 Hz
Narrow Band	Directional Comparison or DTT	2 way	1000 Hz*
Wide Band	Directional Comparison or DTT	1 way	1000 Hz
Wide Band	Directional Comparison or DTT	2 way	2000 Hz*
Wide Band	Dual Comparator Phase Comp.	1 way	1500 Hz
Wide Band	(50/60Hz sq wave keying)	2 way	3000 Hz*
Wide Band	Segregated Phase Comparison	1 way	2000 Hz
Wide Band	(50/60Hz sq wave keying)	2 way	4000 Hz*
Extra Wide Band:	Directional Comparison or DTT	1 way	2000 Hz
Extra Wide Band	Directional Comparison or DTT	2 way	4000 Hz*
Extra Wide Band	Dual Comparator Phase Comp.	1 way	1500 Hz
Extra Wide Band	(50/60Hz sq wave keying)	2 way	3000 Hz*
Extra Wide Band	Segregated Phase Comparison	1 way	2000 Hz
Extra Wide Band	(50/60Hz sq wave keying)	2 way	4000 Hz*

\*An external hybrid or other device offering at least 20 dB rejection of the adjacent channel must be used in the application.

1 way represents transmitter to transmitter or receiver to receiver

2 way represents transmitter to receiver

Table 2–15. Nominal Receiver Bandwidths.

<b>Bandwidth</b>	<b>Nominal</b>	<b>3 dB Point on Band Edge</b>	<b>20 dB Point on Band Edge</b>
ON/OFF			
Narrow	600 Hz	620 Hz	915 Hz
Wide	1200 Hz	1255 Hz	1840 Hz
Extreme Wide	4000 Hz	4400 Hz	5120 Hz
FSK			
Narrow	300 Hz	316 Hz	470 Hz
Wide	600 Hz	620 Hz	915 Hz
Extra Wide	1200 Hz	1255 Hz	1840 Hz

Table 2–16. Environmental Specifications.

Ambient Temperature, range of air	–30 C to +70 C (ANSI C37.90)
Relative Humidity	Up to 95% (non-condensing) at 40 C (for 96 hrs cumulative) (ANSI C93.5)
Altitude	Up to 1500 m (without de-rating), 6000 m with de-rating
Surge Withstand Capability	Per ANSI C37.90.1
1 Minute withstand	IEC 255-5 and ANSI C37.90 (500 volt class)
Coax, center conductor to ground	3000 Vdc impulse level, 1.2 x 50 $\mu$ s impulse, per ANSI C93.5
Dielectric	Per ANSI C37.90, 500 V class (3,000 Vdc dielectric withstand)
Radiated Electromagnetic Interference from Transceivers	35 V/m per ANSI C37.90.2

Table 2–17. Power Requirements.

Nominal Battery Voltage	Permissible Voltage Range	Standby	1 Watt Transmit Single	10 Watt Transmit Single	1 Watt Transmit Dual	10 Watt Transmit Dual
48/60 Vdc	38 to 76 Vdc	25 watts	35 watts	60 watts	*	*
110/125/250 Vdc	88 to 300 Vdc	20 watts	30 watts	66 watts	80 watts	132 watts

\*Not available at this time  
 Permissible ripple on incoming Vdc 5%  
 Maximum allowable frequency of ripple 120 Hz  
 Carrier Frequency on dc input leads when transmitting 1 W 20 mV (max.)

Table 2–18. Weight and Dimension Specifications.

Equipment	Net Weight		Height		Width		Depth		Rack Space
	lbs	Kg	inches	mm	inches	mm	inches	mm	
Single Unit	21	9.53	5.218	132.54	17.515	444.88	13.82	350.98	3 RU
Dual Unit*	35	15.88	7.00	177.9	17.515	444.88	13.82	350.98	4 RU

\* Dual unit not available at this time.

Table 2–19. 4F System Frequencies.

<b>Shift from Center Freq.</b>	<b>600 Hz BW +/- 250 Shift</b>	<b>1,200 Hz BW +/- 500 Shift</b>
Non-keyed	+83 Hz	+166 Hz
Command A	+249 Hz	+498 Hz
Command B	-83 Hz	-166 Hz
Command A & B	-249 Hz	+498 Hz

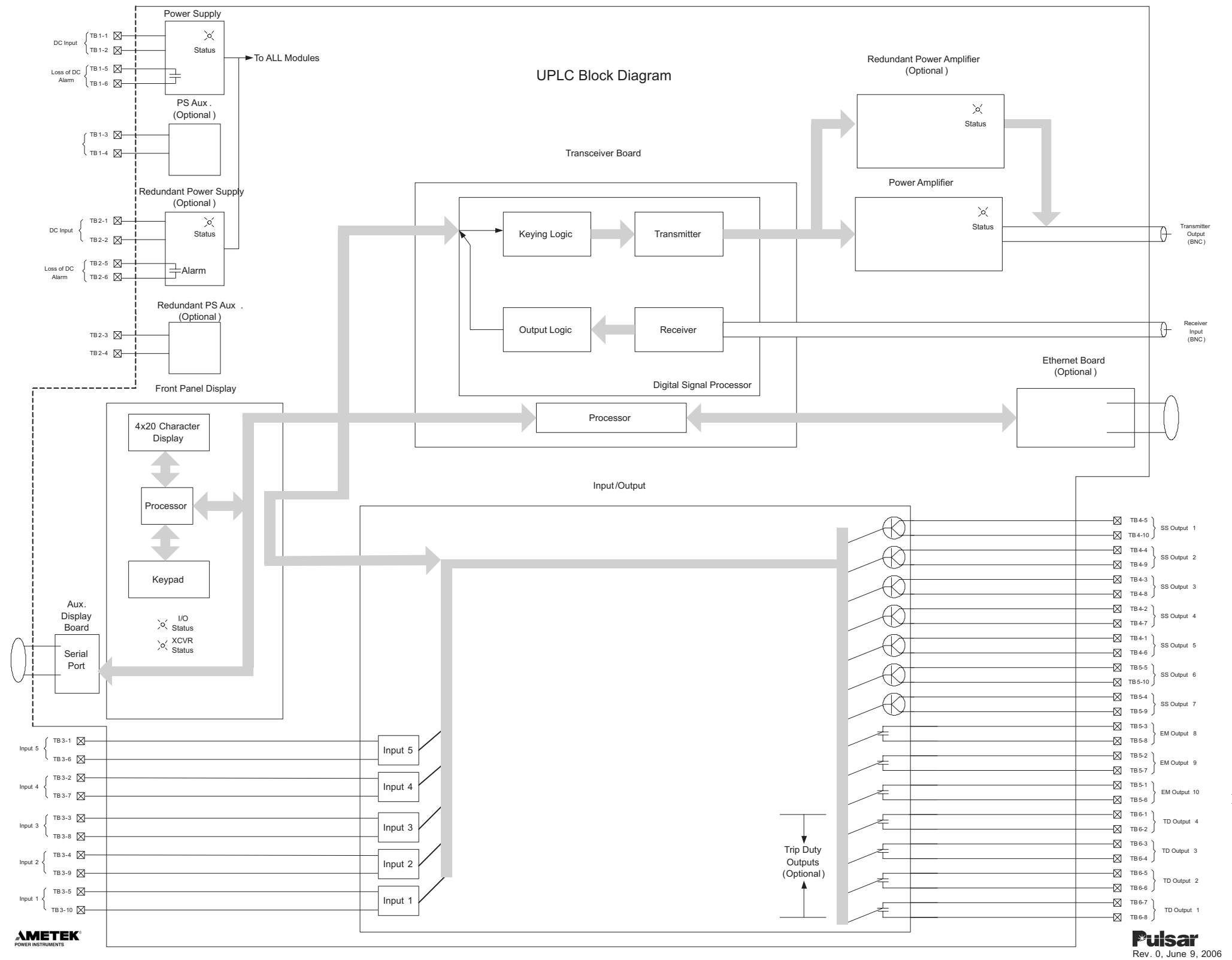
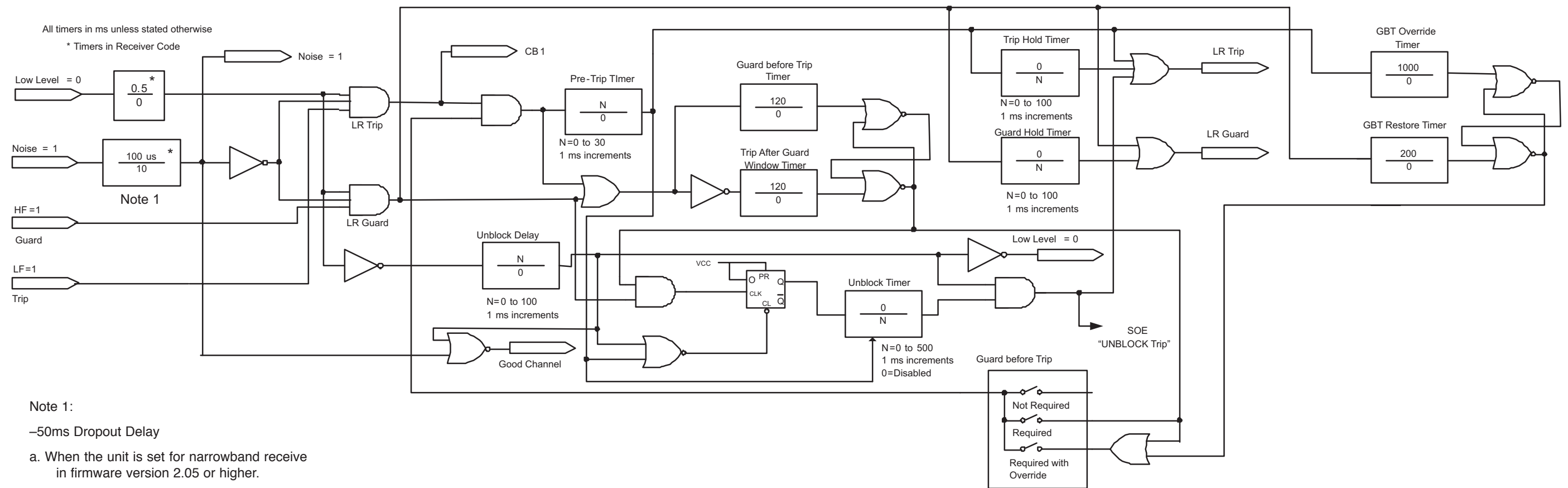

Figure 2-4. Functional Block Diagram.



2 Frequency Logic

Figure 2-5. FSK: 2-Frequency Logic Diagram.

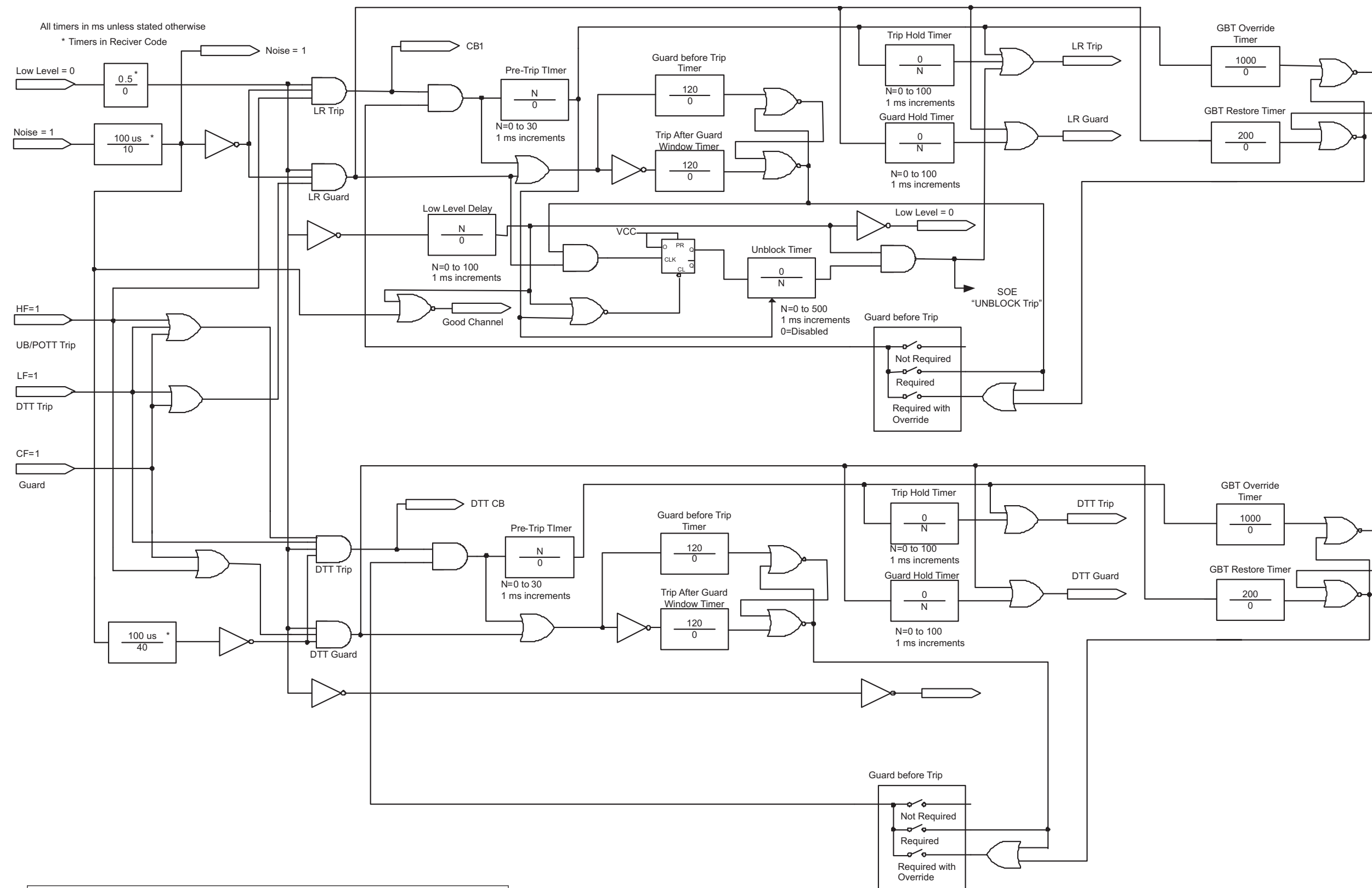

Figure 2-6. FSK: 3-Frequency Logic Diagram.

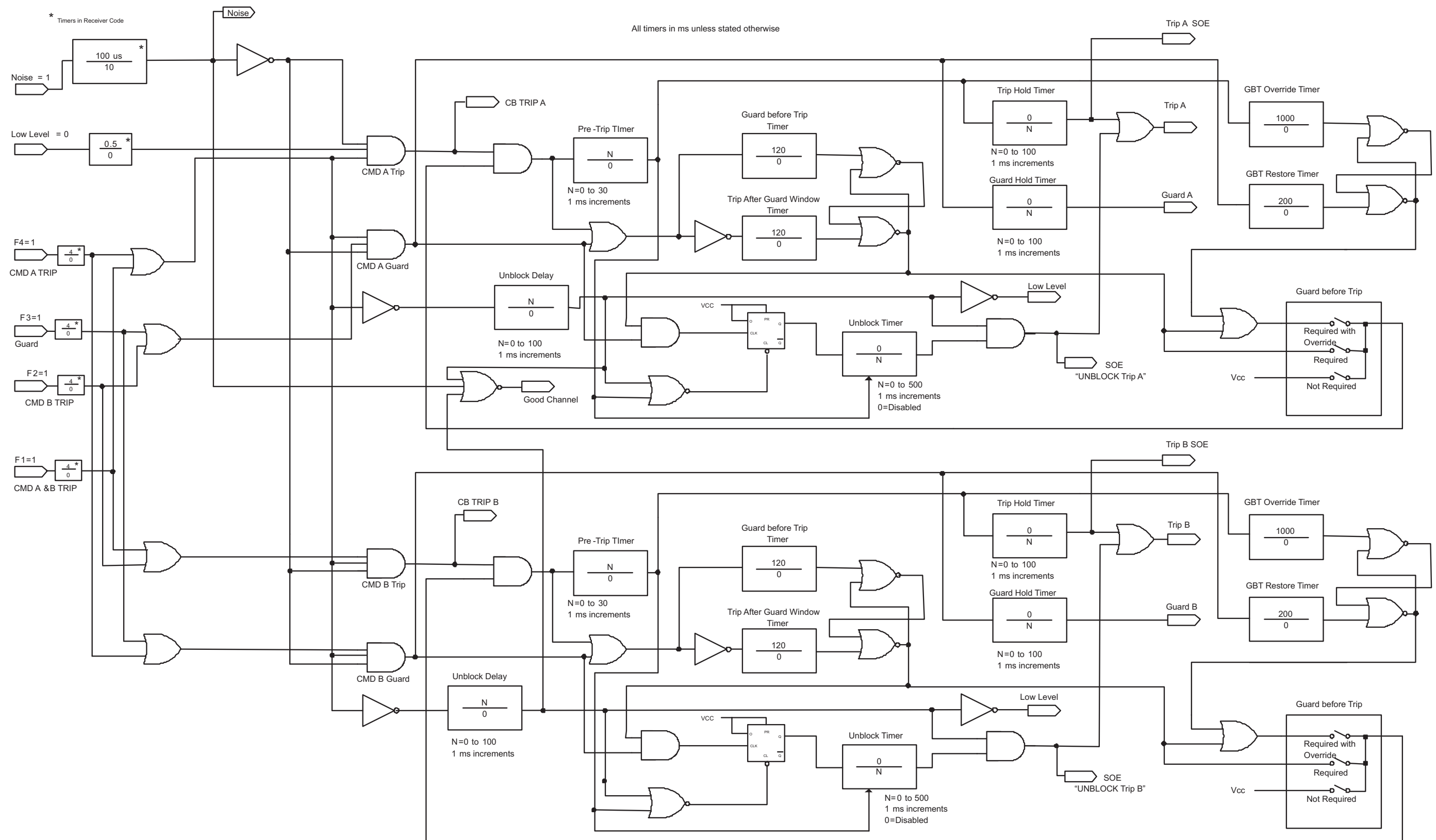

Figure 2-7. FSK: 4-Frequency Logic Diagram.



# Chapter 3. Applications

## 3.1 Protective Relay Applications Using Frequency Shift Carriers

The UPLC™ carrier set is particularly suitable for the following types of protective relay systems:

- Directional Comparison Unblocking
- Permissive Overreaching Transfer Trip (POTT)
- Permissive Underreaching Transfer Trip (PUTT)
- Dual Phase Comparison Unblocking
- Segregated Phase Comparison Unblocking
- Direct Transfer Trip

### 3.1.1 Directional Comparison Unblocking

The Directional Comparison Unblocking systems transmit a continuous blocking signal, except during internal faults. The channel is generally a frequency-shift keyed (FSK) power-line carrier. For an internal fault, the FSK transmitter is shifted to the “unblock” frequency. The transmitted power in many applications is normally 1 W, boosted to 10 W during unblock operation.

The frequency-shift channel is monitored continuously to prevent tripping when a loss of channel occurs. The carrier receiver logic is shown in Figure 3–1. Under normal conditions, a block frequency is transmitted and OR-1 has no input. Because AND-1 and AND-2 are not satisfied, OR-

2 is not energized. For an internal fault, the block frequency is removed. Assuming that the unblock signal is shorted out by the fault, OR-1 provides a direct input to AND-2 to satisfy its input requirements for 150 ms. AND-2 inputs to OR-2 to operate the RR or to provide input to the AND shown in Figure 3–1. Without an unblock signal, 150 ms is allowed for tripping. After this period, lock out is initiated as one of the inputs to AND-2 is removed. This resets the RR or removes the input to AND. If the unblock signal is received, it inputs directly to OR-2 to energize the RR or to provide input to AND. The unblock signal also removes an input to AND-1 to stop the timer. A channel failure (no block or unblock signal) provides input to AND-1 and, after 150ms, locks out the relaying and triggers an alarm. The operation of the scheme shown in Figure 3–4 is given in Table 3–1 for external and internal faults. The phase and ground trip fault detectors at both stations must operate for all internal faults; that is, they must overreach the remote bus.

The dependability and security of Directional Comparison Unblocking systems make them the most attractive of the protective schemes for transmission lines using power-line carrier channels. Over-tripping is avoided by continuous blocking and continuous channel monitoring. Only an external fault within a certain time delay after channel failure can result in over-tripping. This time is selectable from 0-500ms.

The scheme is most appropriate for two-terminal lines, but is applicable to multi-terminal lines. Separate channels are required between each terminal and the remote terminal(s). A sample schematic is shown in Figure 3–2.

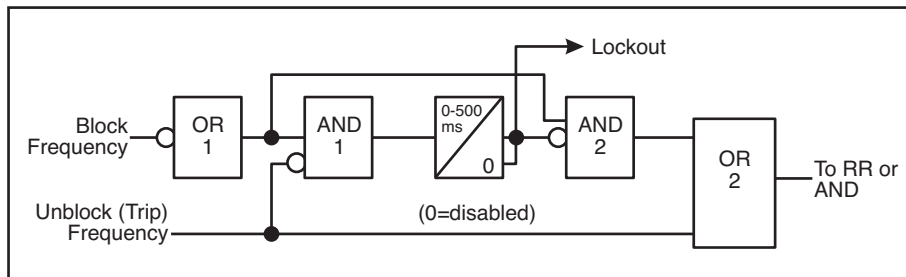
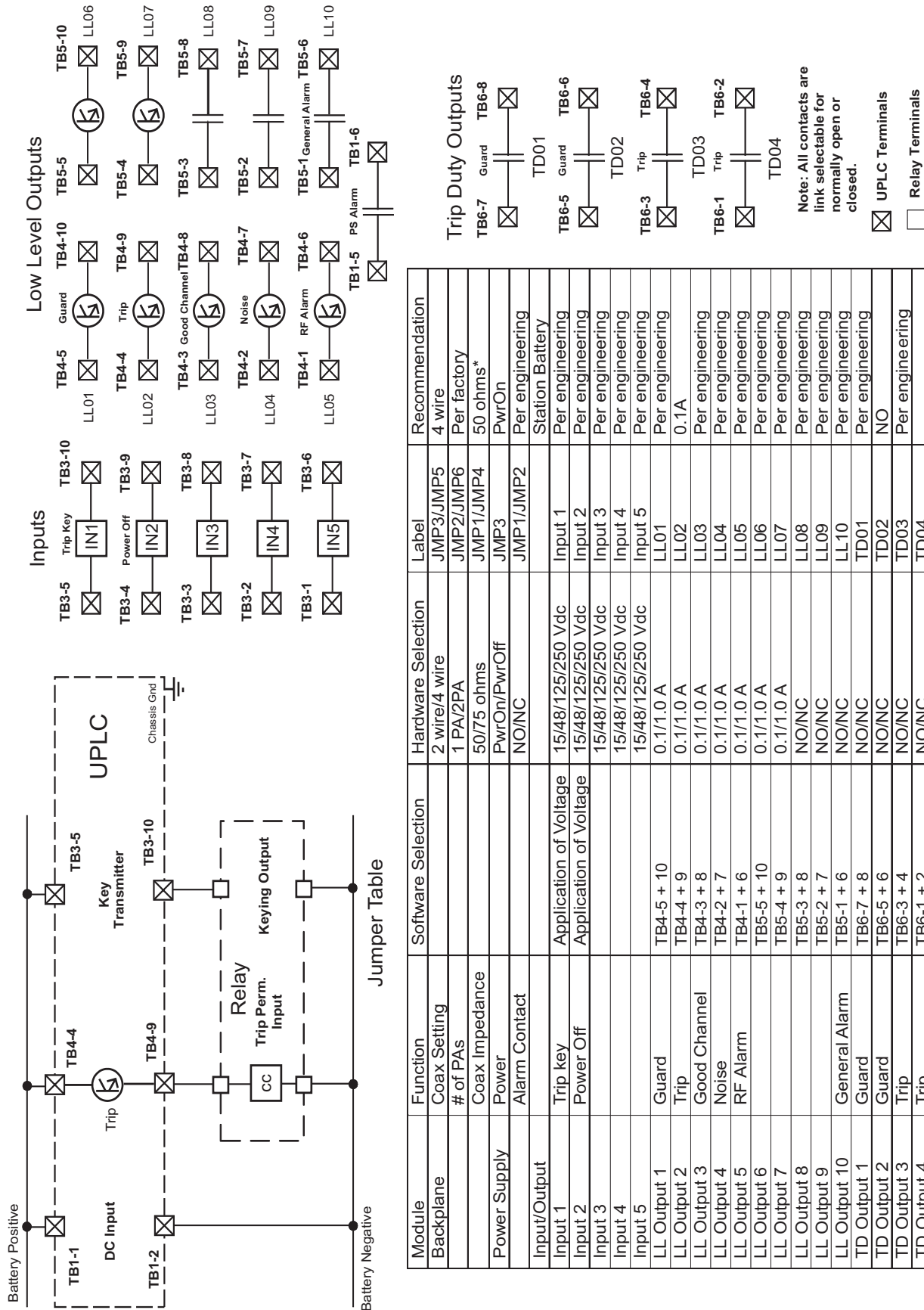

Figure 3–1. Simplified Unblock Receiver Logic.

Fig. 3-2. UPLC™ Transceiver Unit Connections, 2 Freq. set (Directional Comparison Unblock Relaying).



\* Or per engineering's recommendation

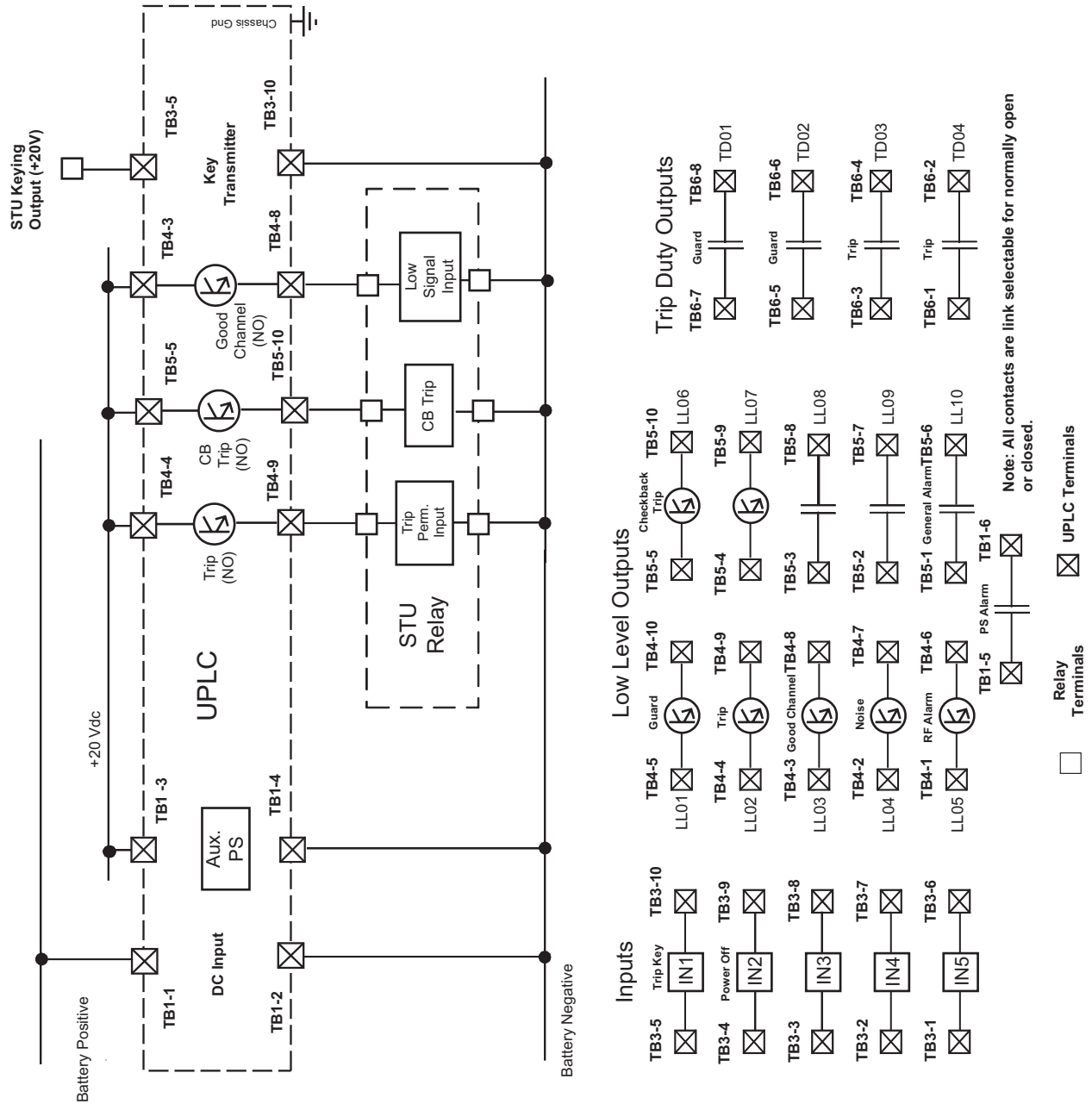

Figure 3-3a. UPLC™ with STU-Unblock Relay System.

Figure 3-3b. UPLC™ with STU–Unblock Relay System.

Programming / Jumper Table

Module	Function	Software Selection	Hardware Selection	Label	Recommendation
Backplane	Coax Setting		2 wire/4 wire	JMP3/JMP5	4 wire
	# of PAs		1 PA/2PA	JMP2/JMP6	Per factory
	Coax Impedance		50 Ω/75 Ω	JMP1/JMP4	50 Ω *
Power Supply	Power		PwrOn/PwrOff	JMP3	PwrOn
	Alarm Contact		NO/NC	JMP1/JMP2	Per Engineering
Aux PS				JMP1/JMP2	46/20V
				JMP3	20V
<b>Input/Output</b>					
Input 1	Trip Key	Application of Voltage	15/48/125/250 Vdc	Input 1	15V
Input 2	Power Off	Removal of Voltage	15/48/125/250 Vdc	Input 2	Per Engineering
Input 3			15/48/125/250 Vdc	Input 3	Per Engineering
Input 4			15/48/125/250 Vdc	Input 4	Per Engineering
Input 5			15/48/125/250 Vdc	Input 5	Per Engineering
LL Output 1	Guard		0.1/1.0A	LL01	Per Engineering
LL Output 2	Trip	NO	0.1/1.0A	LL02	0.1 A
LL Output 3	Good Channel	NO	0.1/1.0A	LL03	0.1 A
LL Output 4	Noise		0.1/1.0A	LL04	Per Engineering
LL Output 5	RF Alarm		0.1/1.0A	LL05	Per Engineering
LL Output 6	Checkback Trip	NO	0.1/1.0A	LL06	0.1 A
LL Output 7			0.1/1.0A	LL07	Per Engineering
LL Output 8			NO/NC	LL08	Per Engineering
LL Output 9			NO/NC	LL09	Per Engineering
LL Output 10	General Alarm		NO/NC	LL10	Per Engineering
TD Output 1	Guard		NO/NC	TD01	Per Engineering
TD Output 2	Guard		NO/NC	TD02	Per Engineering
TD Output 3	Trip		NO/NC	TD03	Per Engineering
TD Output 4	Trip		NO/NC	TD04	Per Engineering

\* Or per engineering's recommendation

**Note:** UPLC programmed for 2F-Unblock Standard Configuration. If used opposite a TCF/TCF-10/TCF-10A, the transmitter and receiver shift needs to be 100 Hz.

You may conserve frequency spectrum by using a narrow band frequency shift carrier, but at the expense of channel speed.

Another consideration is an open breaker situation. When the remote breaker is open for an extended period of time, the relay system must be able to trip. The remote relay system sends a trip signal when detecting a remote open breaker. If this remote signal is received for 1,000 ms (1 sec) or longer, the carrier receiver logic interprets this as an open breaker and allows the local end to trip whenever the local relays detect a fault.

An older system (STU unblock) is shown in Figure 3-3.

### 3.1.2 Permissive Overreaching Transfer Trip Systems

Overreaching transfer trip systems require a channel signal to trip, and are used with a frequency-shift audio tone, modulated on a communication channel (e.g., public or private telephone lines). These systems are generally not used with power-line carriers. There are, however, successful applications of power-line carrier on POTT schemes where parallel lines allow for cross-coupling of the carrier signal.

### 3.1.3 Permissive and Non-Permissive Underreaching Transfer Trip Systems

For overreaching systems, the directional phase and ground trip fault detectors (P) must be set to overlap within the transmission line and not overreach any terminals (see Figure 3-5).

That is, at least one trip fault detector (P) must operate for all internal faults, and none should operate for any external fault. In practice, distance relays are normally required for both ground faults and phase faults, although directional instantaneous ground-overcurrent relays might meet these requirements in some cases.

Though it is the least complex, the non-permissive system is rarely used because of the high potential for false outputs from the channel, which would cause incorrect tripping. If a non-permissive system is used, the channel considerations should be as described later for direct trip systems. The system is made permissive by the additional set of phase and ground overreaching fault detectors (FD), which must operate for all internal faults (see Figure 3-5).

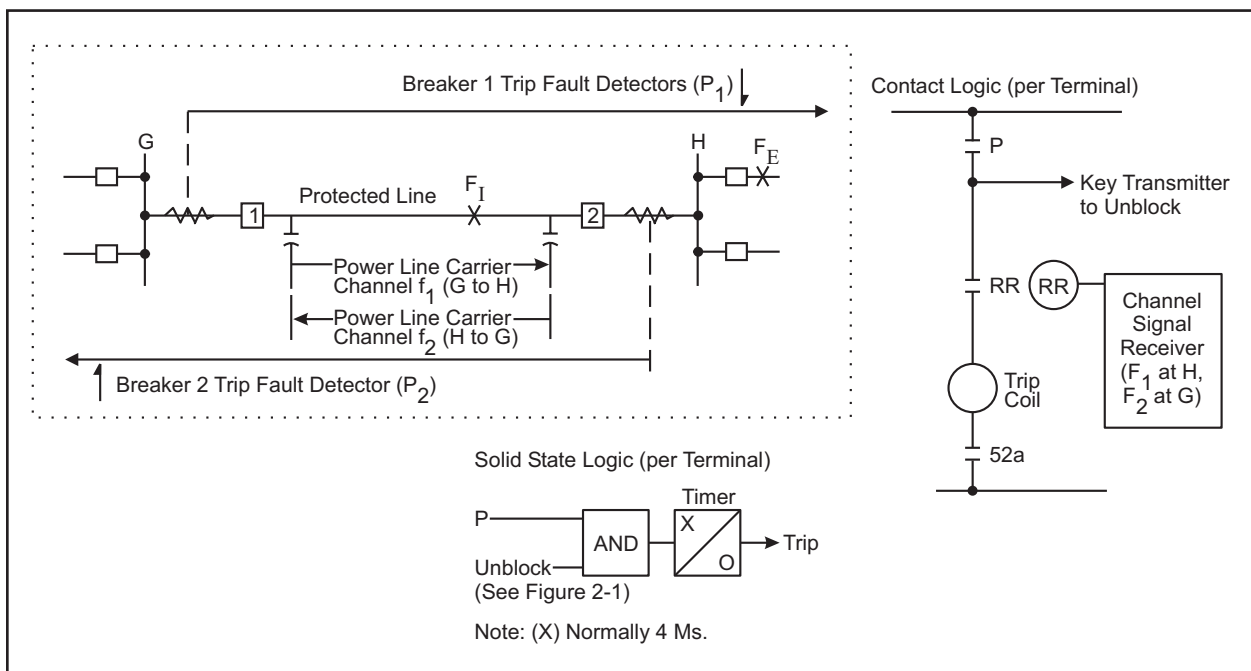

Figure 3-4. Basic Logic Diagrams for Directional Comparison Unblocking.

Table 3–1. Operation of the Directional Comparison Unblocking Scheme.

SCHEME FOR EXTERNAL AND INTERNAL FAULTS		
Type of Fault	Events at Station G	Events at Station H
External ( $F_E$ )	<p><math>P_1</math> operates.</p> <p><math>f_1</math> channel shifts to unblock.</p> <p><math>f_2</math> channel continues to block.</p> <p>No trip.</p>	<p><math>P_2</math> does not see fault.</p> <p>Loss of block and/or receipt of unblock (<math>f_1</math>) operates RR or inputs AND.</p> <p>No trip.</p>
Internal ( $F_I$ )	<p><math>P_1</math> operates.</p> <p><math>f_1</math> channel to unblock.</p> <p>Loss of block and/ or receipt of unblock (<math>f_2</math>) operates RR or inputs AND.</p> <p>Trip.</p>	<p><math>P_2</math> operates.</p> <p><math>f_2</math> channel shifts to unblock.</p> <p>Loss of block and/or receipt of unblock (<math>f_1</math>) operates RR or inputs AND.</p> <p>Trip.</p>

Table 3–2. Operation of the Underreaching Transfer Trip Scheme.

SCHEME FOR EXTERNAL AND INTERNAL FAULTS		
Type of Fault	Events at Station G	Events at Station H
External ( $F_E$ )	<p><math>P_1</math> does not operate.</p> <p>No channel signal sent to H.</p> <p>No trip.</p>	<p><math>P_2</math> does not operate.</p> <p>No channel signal sent to G.</p> <p>No trip.</p>
Internal ( $F_I$ ) (Fault near station H)	<p><math>P_1</math> does not operate.</p> <p>No channel signal sent to H.</p> <p>†(<math>FD_1</math> operates).</p> <p>Transfer-trip (<math>f_2</math>) from station H operates RR or inputs to AND (or OR if non-permissive).</p> <p>Trip.</p>	<p><math>P_2</math> operates and trips directly.</p> <p>Transfer-trip signal keyed to station G.</p> <p>†(<math>FD_2</math> operates).</p> <p>Trip.</p>

† Omitted in non-permissive systems.

Operation of the underreaching transfer trip scheme shown in Figure 3–5 is described in Table 3–2 for external and internal faults.

Because the trip fault detectors (P) do not operate for external faults, underreaching transfer trip systems do not require external fault-clearing coordination circuits (transient blocking) and are, therefore, inherently simpler than any of the other schemes. You obtain maximum security if you use additional permissive fault detectors. These schemes also provide minimum operating times for many faults that are tripped directly, without using the channel.

### 3.1.4 Dual Phase Comparison Unblocking Systems

Dual comparison systems require a duplex channel: one frequency for each line terminal. The UPLC™ frequency-shift channel equipment is available for this purpose; normally used in an unblocking system. Continuous channel monitoring is also provided, because either a trip positive or trip negative carrier signal is always transmitted.

The transmitter is keyed to its trip positive frequency when the square wave from the filter goes positive, and is keyed to its trip negative frequency when the square wave is at zero. There are two outputs at the receiver: the trip positive output is a square wave that goes positive when a trip positive frequency is received; the trip negative output goes positive when a trip negative frequency is received.

The basic operation of the Dual Phase Comparison system is shown in Figure 3–6. For internal faults, the single phase outputs of the sequence current networks are essentially in phase, although such

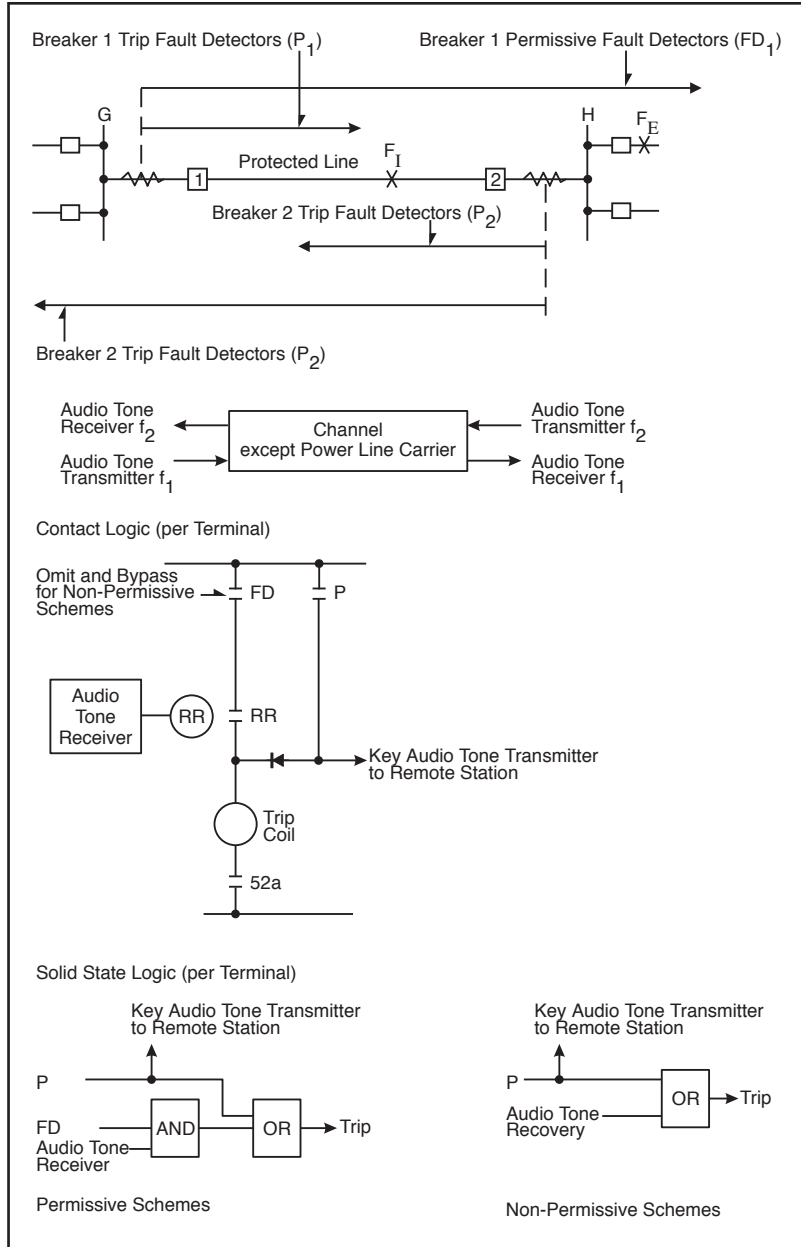

Figure 3–5. Basic Logic Diagrams for Underreaching Transfer Trip Systems.

output represents currents 180° apart in the power system. The network output goes through a squaring amplifier that keys the frequency shift transmitter. An adjustable delay circuit delays the local square wave by a time equal to the channel delay time.

The network output is then used to develop two complementary square waves. One wave, which has a positive state during the positive half-cycle of the sequence current network, is compared with the

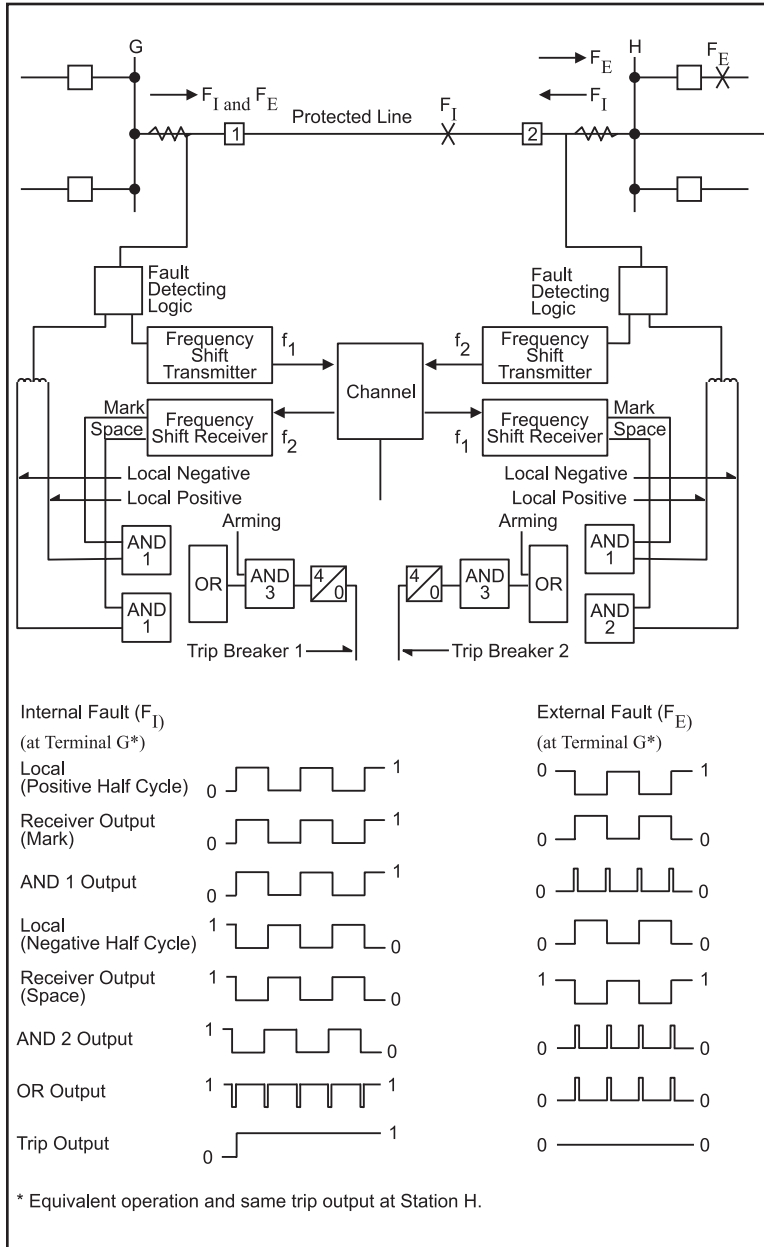

Figure 3-6. Basic Operation of the Dual Phase Comparison Pilot Relaying System.

receiver’s trip positive output. The other wave, which has positive output during the negative half-cycle of the sequence current network, is compared to the receiver’s trip neg. output in a second comparison circuit.

On internal faults, the positive half-cycle of the local square wave lines up with the received trip positive output to provide an AND-1 output. On the negative half-cycle, this local square wave lines

up with the received trip negative output to provide an AND-2 output. If an arming signal is received ( $FD_2$  and/or 21P) and either AND-1 or AND-2 output exists for 4ms, an input to the trip flip flop initiates breaker tripping. The same operation occurs at both terminals, tripping breakers 1 and 2 simultaneously on either half-cycle of fault current.

For tripping, both the trip positive and trip negative frequencies must be transmitted through the internal fault via power-line carrier channels. If these frequencies are not received, the receiver detects a loss of channel and clamps both outputs to a continuous positive state. This loss of channel clamp enables both comparison circuits, allowing the system to trip on the local square wave input only. After 150ms, the system output clamps these to the zero state. At this point, the system cannot trip and is locked out. An alarm indicates loss of channel.

For external faults, the reversal of current at one end shifts the square waves essentially 180°. As a result, neither AND-1 nor AND-2 has the sustained output required to operate the 4ms timer. No trip occurs at either line terminal.



### 3.1.5 Segregated Phase Comparison System

The Segregated Phase Comparison system has been developed to improve pilot relay protection, particularly for the long EHV series capacitor-compensated transmission lines. Long EHV series capacitor-compensated lines are a source of significant transients during the fault period. Under these circumstances, sequence current networks designed to operate at normal system frequency may present a problem. The experience with these Phase Comparison systems has, however, been remarkably good. Directional Comparison systems, on the other hand, are subject to misoperation on series capacitor-compensated lines, particularly if the capacitor gaps do not short the capacitors on faults. Segregated phase comparison systems, which are current-only, are independent of the following phenomena:

- Power system frequency and wave form
- Effects of impedance unbalance between the power system phase circuits.
- Maximum load/minimum fault current margin.

The segregated phase comparison system can be divided into two types: a two-subsystem scheme and a three-subsystem scheme. In the two-subsystem scheme, one subsystem operates from delta current ( $I_a - I_b$ ) for all multi-phase faults, and a ground ( $3I_0$ ) current subsystem operates for all ground faults. The three-subsystem scheme has a subsystem for each phase ( $I_a$ ,  $I_b$ , and  $I_c$ ). Each subsystem consists of one channel (UPLC™) and one Phase Comparison relay.

Both segregated Phase Comparison systems incorporate “offset keying”, enabling them to trip for internal high-resistance ground faults and internal faults with outfeed at one terminal. No other system can clear these types of faults without extra logic or channels. On a 500 kV line with a 2,000:5 current transformer ratio, for example, the three-subsystem scheme will operate for ground-fault resistances up to about 100 Ω primary impedance. Under the same conditions, the two-subsystem scheme will operate up to about 200 Ω primary fault resistance.

The two-subsystem package is suitable for all applications except single-pole tripping, where the three-subsystem package must be applied. The basic operation of the scheme is illustrated in Figure 3–7. Each current is fed through a non-inductive resistor, supplying a voltage output to the squaring amplifier (SA) that is exactly proportional to the primary currents. The output of these amplifiers is used to key the individual channels and, through the local delay timers (LDT), to provide the local square waves for comparison. The timers are adjustable between 2 and 20ms to compensate for the delay time of the channel. This digital delay circuit translates the pulse train independently of the pulse width ratio, in contrast to the ac phase angle shift used in the other systems. The ac phase shift delay uses frequency-dependent components, which are accurate only at system frequency and can “ring” during transient conditions.

The square wave comparison is made independently for each current in the separate subsystems. Separate channels are required for each of the subsystems. One of the comparison circuits is shown in simplified form in Figure 3–8. In this dual comparison circuit, AND-P is used for the positive half-cycles and AND-N for the negative half-cycles. As shown in Figure 3–8, the received positive square wave corresponds to a “1” input to AND-P, and the received negative square wave to a “0” input, negated to “1”, into AND-N. Except for this variation, operation is as shown by the square wave blocks in the lower half of Figure 3–6.

To generate the local and keying square waves, conventional phase comparison systems use thresholds equivalent to (or very near) the zero axis. As a result, an internal fault with outfeed looks like an external fault to those systems (see Figure 3–9). The offset keying technique permits the relay system to trip for internal faults with outfeed current out at one terminal. While the outfeed condition is very unusual, it presents difficult problems to the great majority of pilot relaying

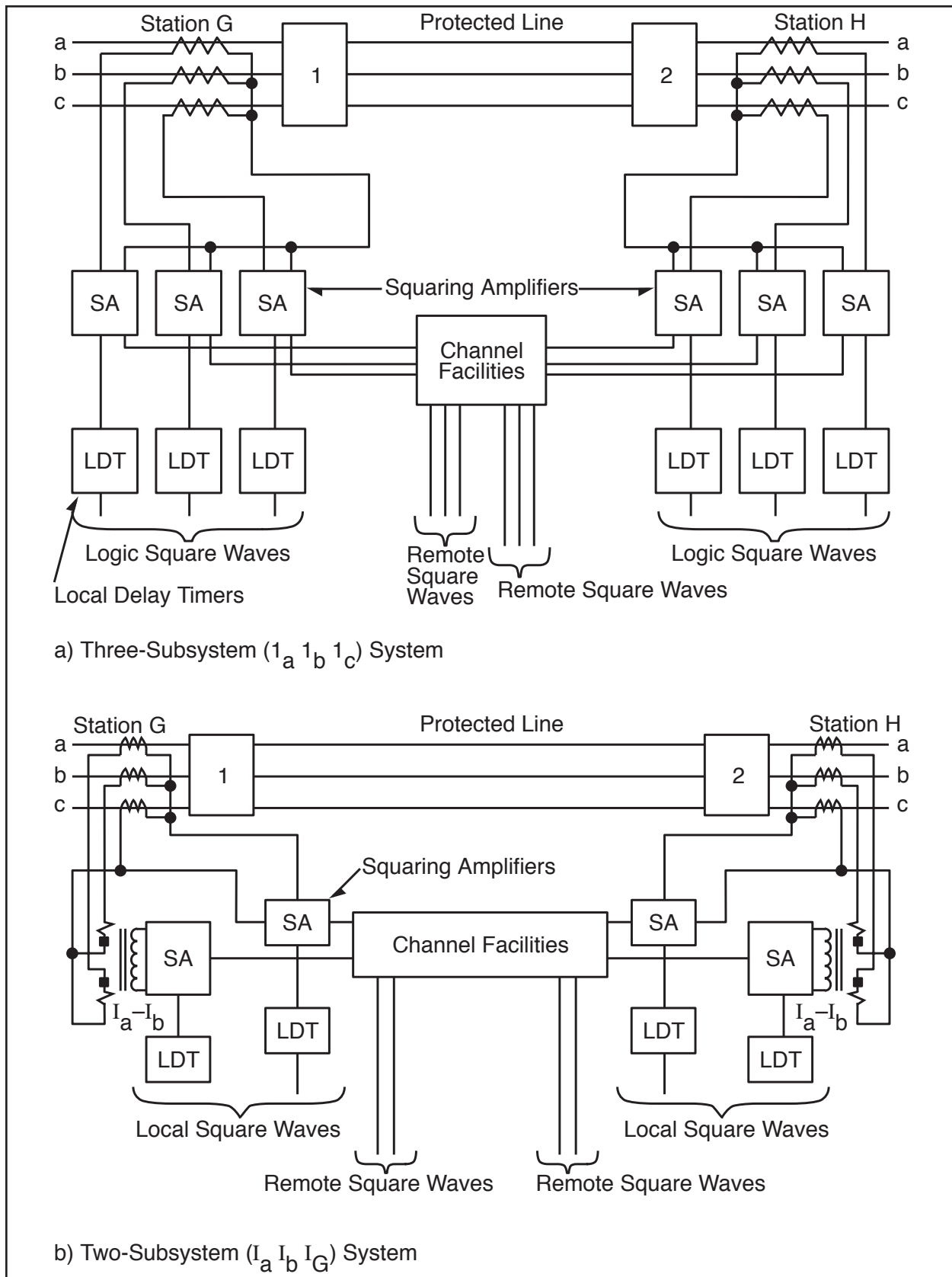

Figure 3-7. Basic Segregated Phase Comparison Systems.

systems when it does occur. Outfeed can occur in any of the following cases:

- Series-capacitor-compensated parallel lines.
- Weak-feed or zero-feed applications, particularly with heavy through load.
- Some multi-terminal applications.
- Series-compensated (line-end compensation) line with a source inductive reactance smaller than series capacitor reactance.
- Some single-line-to-ground faults, occurring simultaneously with an open conductor, where the fault is on one side of the open conductor.
- Some single-line-to-ground faults with high fault resistance and heavy through load (such conditions can cause outfeed only in the faulted phase current, not in the ground subsystem).

The offset keying technique allows the relay system to work like a true current differential scheme. The scheme takes advantage of the fact that, for the outfeed condition, the current into the line is greater in magnitude than the current out of the line for the internal fault.

This relationship is illustrated in Figure 3–9, where  $I_G$  equals  $I_F$  plus  $I_H$ . While the two terminal currents may have any angular relationship with one another, most outfeed conditions display a nearly out-of-phase relationship. The out-of-phase condition illustrated is the most difficult case for phase comparison, as well as the most common outfeed condition.

In the offset keying technique, the keying threshold is displaced in the positive direction, away from the zero axis. The local square wave thresholds are displaced negatively. To maintain security, the local thresholds are separated from each other, providing “nesting” during external faults. Typical settings are shown in Figure 3–10.

Figure 3–11 illustrates the square wave characteristics of offset keying for normal internal faults, external faults, and internal faults with outfeed.

The segregated Phase Comparison scheme incorporates a high degree of security. Its design is based on extensive field experience and the model line tests for the very long, series capacitor-compensated EHV lines.

Output trip signals are supervised by an arming input and a number of security checks (see Figure 3–9). Phase arming is performed by a current rate-of-change detector that responds to sudden increases, decreases, or angular shifts in current. It operates on current changes of 0.5 A or more, with an operating time of 2 ms. Ground arming is 3I magnitude—typically 0.8 A secondary.

Security checks to comparison AND (see Figure 3–9) include (1) low channel signal blocking, (2) lockout for sustained low channel signal, (3) channel noise clamp, and (4) receive guard block. For the phase subsystems, a trip signal occurs if comparison AND has an output for more than 3ms (4ms for the ground subsystem).

## 3.2 Direct Transfer-Trip Systems

Direct transfer-trip systems provide circuit-breaker tripping at remote or receiver terminals, without any supervision by fault detectors. The most important consideration in a direct transfer-trip system is the type of channel applied. The communications equipment must carry the total burden of system security and dependability.

Direct transfer-trip systems are applied for:

- Line protection with non-permissive under reaching transfer-trip systems.
- Transformer protection where there is no circuit breaker between the transformer and transmission line.
- Shunt reactor protection.
- Remote breaker failure protection.

A sample schematic is shown in figure 3-12.

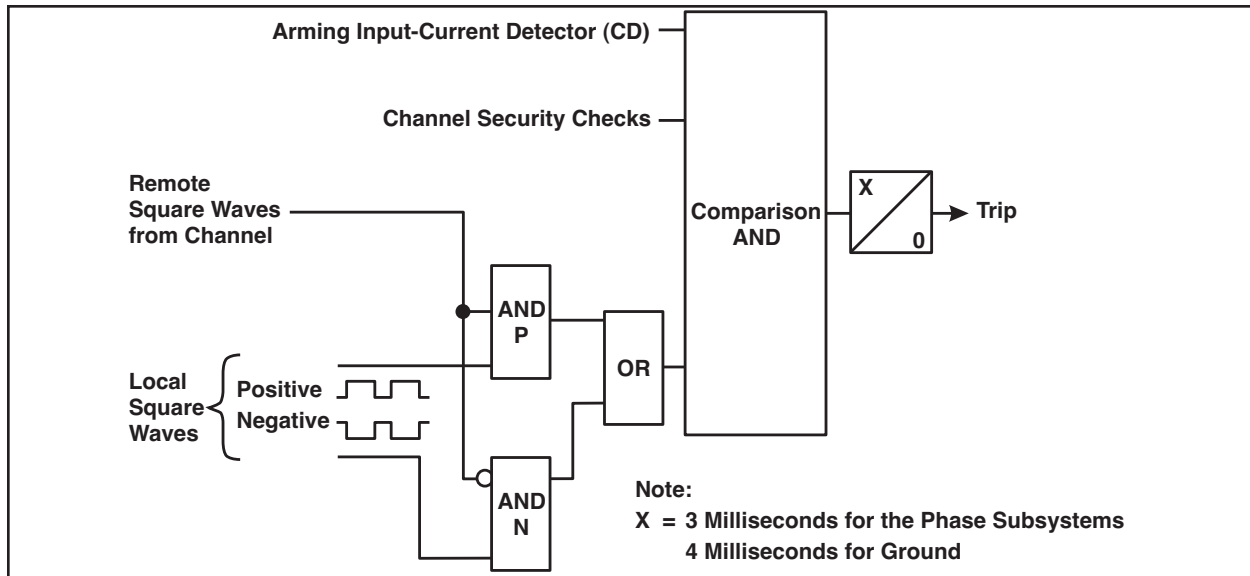

Figure 3–8. Basic Operation of the Segregated Phase Comparison System.

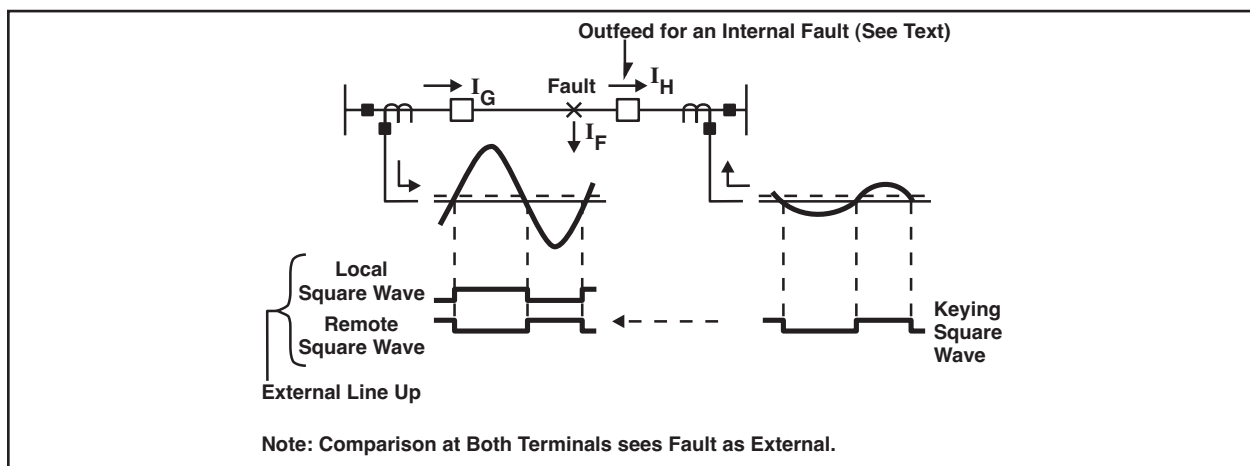

Figure 3–9. Conventional Phase Comparison Response to an Outfeed Condition Block Tripping.

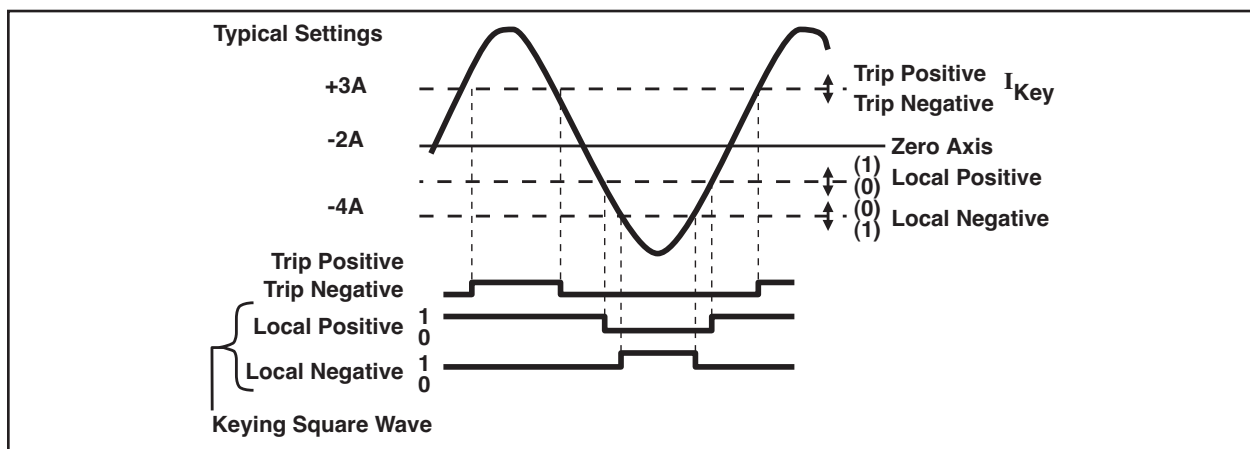

Figure 3–10. Typical Threshold Setting for Offset Keying.

### 3.2.1 Transformer Protection

A typical transformer protection scheme is illustrated in Figure 3–13. A direct trip channel is keyed to the trip state when the transformer protective relays operate. The received trip signal will then trip the remote end breaker and lock out reclosing.

Although it is no longer widely used, you may use a ground switch operated by the transformer protective relays for transformer protection. In this technique, a ground fault is initiated on the transmission line at G, providing adequate fault current for the ground relays at H to trip the breaker at H. This system is slower but is widely used on lower voltage systems and is fairly simple and straightforward. It does not require any secure communication medium between G and H. For this type of application, the ground relays at H can be set to operate for 100 percent of the line and not overreach to bus G.

While a single switch on one phase is normally applied, you may use a double switch on two phases to initiate a double-phase-to-ground fault. In the latter case, both phase and ground relays can operate to ensure redundancy. Fault grounding is not applicable to all systems because of high short-circuit capacity.

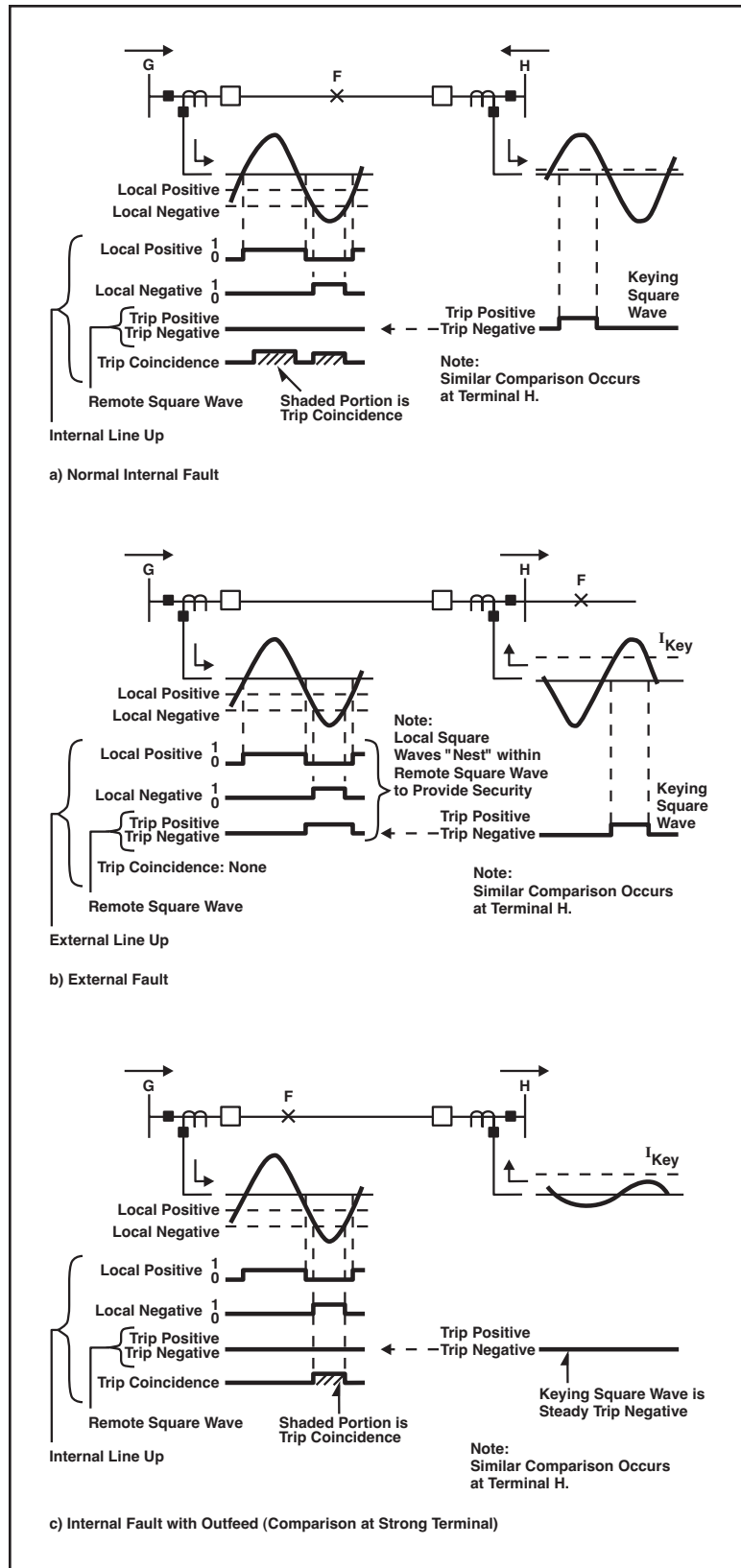
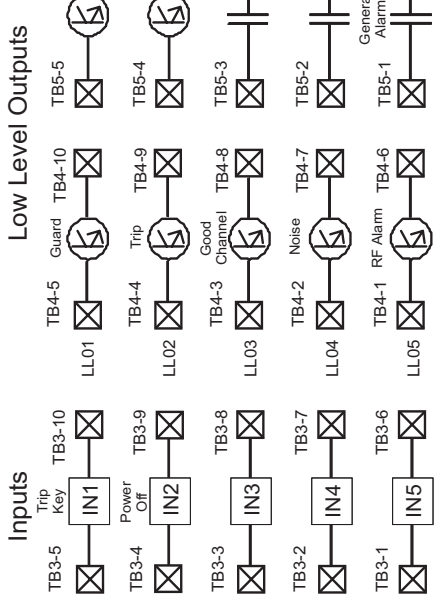
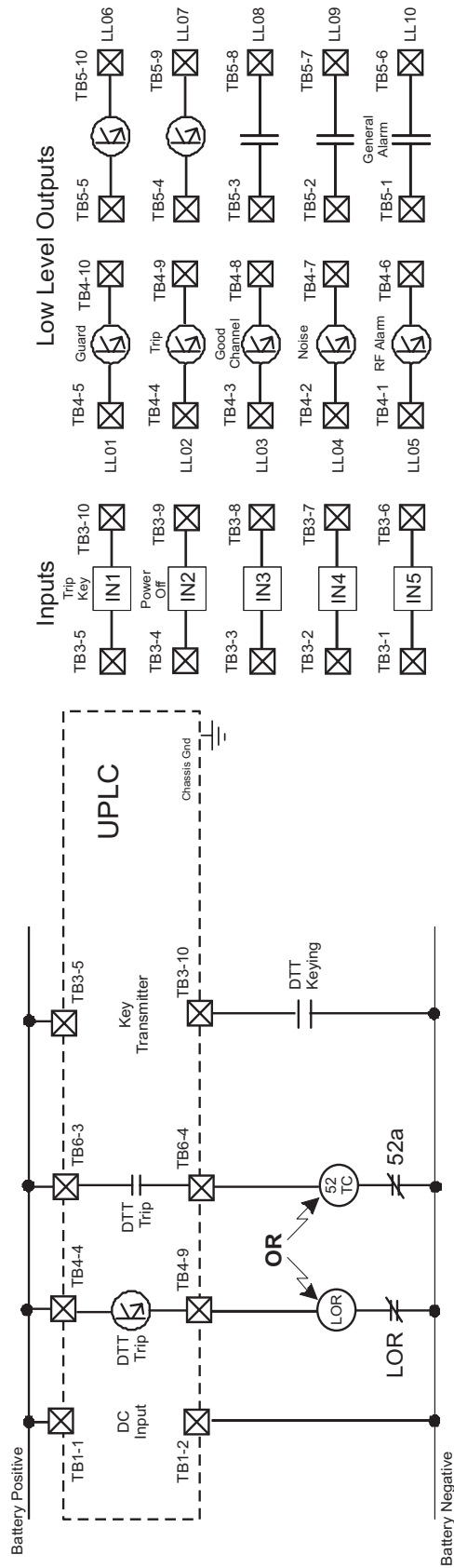

Figure 3–11. Response of Segregated Phase Comparison System with Offset Keying.

Fig 3-12. Transceiver Unit Connections 2 Freq. set (Single Channel Direct Transfer Trip).



Jumper Table

Module	Function	Software Selection	Hardware Selection	Label	Recommendation
Backplane	Coax Setting	2 wire/4 wire	1 PA/2PA	JMP3/JMP5	4 wire
	# of PAs			JMP2/JMP6	Per factory
Power Supply	Coax Impedance	50/75 ohms		JMP1/JMP4	50 ohms*
	Power		PwrOn/PwrOff	JMP3	PwrOn
Input/Output	Alarm Contact		NO/NC	JMP1/JMP2	Per engineering Station Battery
	Trip key		Application of Voltage	Input 1	Per engineering
Input 1-5	Power Off		Application of Voltage	Input 2	Per engineering
				Input 3	Per engineering
				Input 4	Per engineering
				Input 5	Per engineering
				Input 5	Per engineering
LL Output 1-5	Guard		0.1/1.0 A	LL01	Per engineering
	Trip		0.1/1.0 A	LL02	1.0A
	Good Channel		0.1/1.0 A	LL03	Per engineering
	Noise		0.1/1.0 A	LL04	Per engineering
	RF Alarm		0.1/1.0 A	LL05	Per engineering
LL Output 6-10			0.1/1.0 A	LL06	Per engineering
			0.1/1.0 A	LL07	Per engineering
			NO/NC	LL08	Per engineering
	General Alarm		NO/NC	LL09	Per engineering
	Guard		NO/NC	LL10	Per engineering
TD Output 1-4	Guard		NO/NC	TD01	Per engineering
	Trip		NO/NC	TD02	Per engineering
			NO/NC	TD03	Per engineering
	Trip		NO/NC	TD04	NO

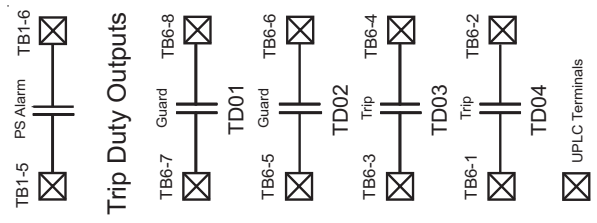

Note: All contacts are link selectable for normally open or closed.

\* Or per engineering's recommendation

### 3.2.2 Shunt Reactor Protection

Shunt reactors are frequently used on HV and EHV lines. These line reactors are connected on the line side of the circuit breakers (see Figure 3–12). A remote trip channel is thus required for a fault in the shunt reactor.

### 3.2.3 Remote Breaker-Failure Protection

A remote breaker-failure system is necessary where a multi-breaker bus, such as a breaker-and-a-half or ring bus scheme, is applied at a transmission line terminal. A direct transfer-trip system will be a part of the remote breaker-failure protection.

### 3.2.4 Direct Transfer Trip Channel Considerations

The channel and its terminal equipment are major factors in the proper operation of the direct transfer-trip system. The DTT channel must neither fail to provide a correct trip signal nor provide a false signal.

While other types of modulation are possible, frequency-shift keyed (FSK) equipment offers the best compromise between noise rejection capability and equipment complexity. Two frequencies are usually transmitted in an FSK system: the “guard” frequency is transmitted during non-trip conditions and the “trip” frequency is transmitted when a breaker trip is required. Because a signal is always present, the FSK system will allow the

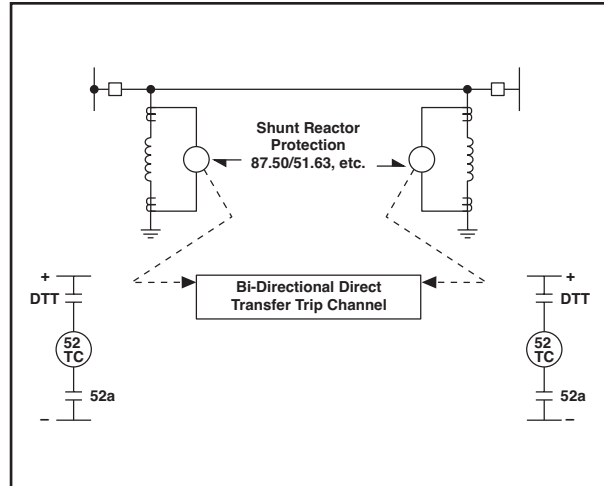

Figure 3–14. Direct Transfer Trip for Shunt Reactor Protection.

channel to be continuously monitored. Continuous channel monitoring is necessary in a direct trip system, because breaker tripping is not supervised by any local relays.

As noise in the channel increases, a point is reached where there is a high probability of false tripping. The level of noise at which the channel becomes unreliable must be determined by tests. Signal-to-noise ratio monitors must then be included with any direct trip channel, to block possible false tripping. It is important, however, not to get the noise monitors any more sensitive than required, since their operation will prevent tripping.

There are three important aspects to the application of FSK channels to direct trip systems: channel bandwidth, dual channel systems, and channel protection.

Although faults should be cleared in the shortest possible time, speed is not the only criterion for selecting equipment. *It is important to use the narrowest bandwidth equipment possible.* A wide bandwidth channel may give the desired speed, but more noise enters the system. Thus, the channel will block tripping sooner than a narrower bandwidth channel with the same received signal level. A wideband channel will consequently not be as dependable as a narrower channel under equal receive-level conditions.

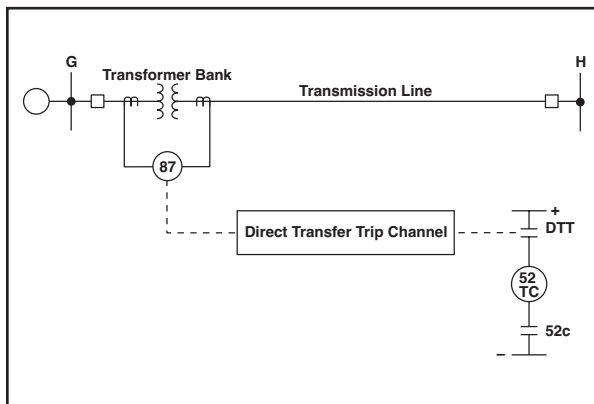

Figure 3–13 Direct Transfer Trip for Transformer Protection.

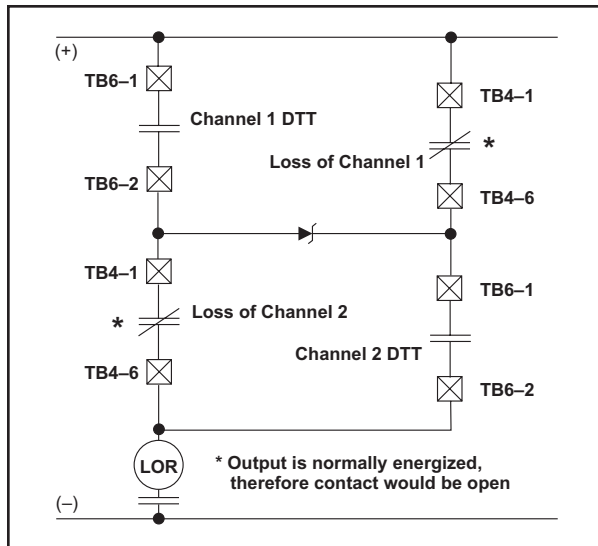

Figure 3-15.

Dual Channel Direct Transfer Trip with Throwover to Single Channel.

A dual channel system is recommended for direct trip applications. Two FSK channels should be used in series, so that both must trip before the breaker is tripped. Many tests have indicated that dual channels improve the security of the direct trip system by several orders of magnitude. Use of a dual channel system has very little effect on dependability, even if both channels are on the same transmission medium.

If you want to increase the dependability, you can modify the dual channel transfer trip scheme to allow a single channel trip when there is failure of the other channel. A typical Dual Channel Throwover to Single Channel Scheme is illustrated in Figures 3-15 & 3-16.

### 3.3 Special Considerations

The UPLC™ frequency-shift equipment can operate in either the two- or three-frequency mode. The three basic frequencies are as follows (see Figure 3-17):

- $f_C$  Center frequency
- $f_H$  High-frequency, is a frequency shift ( $\Delta f$ ) above  $f_C$

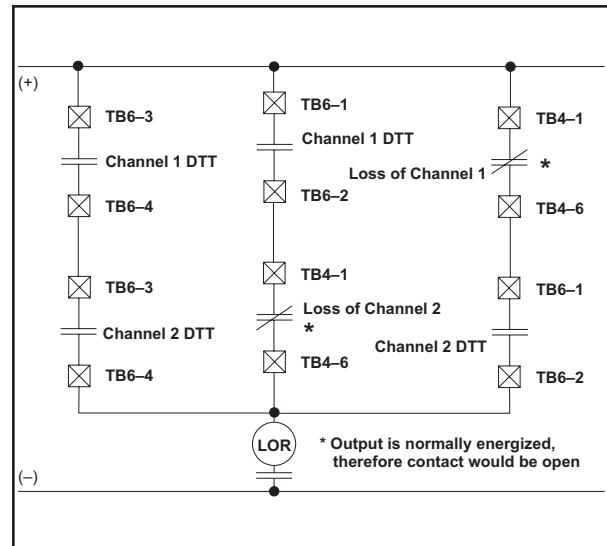

Figure 3-16.

Dual Channel Direct Transfer Trip with Throwover to Single Channel.

$f_L$  Low-frequency, is a frequency shift ( $\Delta f$ ) below  $f_C$

The value of  $\Delta f$  depends on the bandwidth of the UPLC™ set. For a bandwidth of 1200 Hz,  $\Delta f$  is 500 Hz. A bandwidth of 300 Hz yields a  $\Delta f$  of 100 Hz, while the 600 Hz bandwidth  $\Delta f$  can be either 250 or 100 Hz. The center channel frequency ( $f_C$ ) can vary from 30 to 535 kHz (in 0.1 kHz steps).

In the two-frequency systems, only  $f_H$  and  $f_L$  are used. The two frequencies function differently and take on different labels when operating with the different types of protective relay systems.

#### 3.3.1 Directional Comparison Unblocking (2-Frequency)

The higher frequency ( $f_H$ ), or “Guard” frequency, is transmitted continually as a blocking-type signal during normal conditions, to indicate that the channel is operative and to prevent remote relay tripping when external faults occur.

For a fault sensed by the local overreaching pilot relay, the transmitter is frequency-shifted to a low frequency ( $f_L$ ), called “Unblock” frequency. The



transmitted power is normally 1 W, boosted to 10 W for the “Unblock” operation.

The Directional Comparison Unblocking system will generally use the wide band, wide shift (600 Hz BW,  $\pm 250$  Hz Shift) UPLC™ carrier set. Also, the most common power output level used will be the 1 watt block and 10 watt trip. The type of carrier applied with this scheme may be varied from the normal for special circumstances, e.g., when matching the new UPLC™ equipment at one end of the line with the older TCF, TCF-10, TCF-10A or TCF-10B equipment at the other end. In this case, you must apply the wide band, narrow shift carrier (600 Hz BW,  $\pm 100$  Hz Shift) to match the older carrier characteristics.

### 3.3.2 Transfer Trip: Overreaching, Underreaching or Direct (2-Frequency)

The higher frequency ( $f_H$ ), or “Guard” frequency, is transmitted continually during normal conditions. For a fault sensed by the overreaching (or underreaching) pilot relay, the transmitter is shifted to the low frequency ( $f_L$ ), called “Trip” frequency.

When using the UPLC™ or any permissive overreaching or underreaching line relay system, you can apply any bandwidth set. However, the best all around set to use will be the wide band, wide shift (600 Hz BW,  $\pm 250$  Hz Shift) equipment. If signal-to-noise ratio is of concern, however, you may use the narrow band set; on the other hand, if relay speed is critical, you may apply the extra wide band (1200 Hz,  $\pm 500$  Hz Shift) equipment. If, in direct transfer trip systems, security due to S/N is of concern, we strongly recommend that you apply only narrow band equipment. In any of these systems, the usual power level combination will be 1 W for guard and 10 W for the trip signal.

### 3.3.3 Phase Comparison Unblocking: Dual or Segregated (2-Frequency)

Phase Comparison relays use square wave signals for operation. The transmitter is keyed to a “Trip Positive” frequency when the relay square wave

goes positive, and is keyed to a “Trip-Negative” frequency when the relay square wave is at zero. The Trip Positive frequency is frequency-shifted below  $f_C$ ; the “Trip Negative” frequency is frequency-shifted above  $f_C$ . Either frequency can function as a trip or block, depending on the local square wave.

For Phase Comparison systems, you can use only the wide band with wide shift or extra wide band UPLC™. In the interest of conserving spectrum, the wide band, wide shift channel is most common. However, if speed is important, you may apply the extra wide band set. The most often applied power level will be 10 watts for both “Trip-Positive” and “Trip-Negative”.

### 3.3.4 Three-Frequency Systems

The UPLC™ also provides for three-frequency system applications (see Figure 3–17), e.g., Directional Comparison Unblocking with Direct Transfer Trip, or Permissive Overreaching Transfer Trip with Direct Transfer Trip. All three frequencies are closely-controlled discrete frequencies within the equivalent spacing of a single wideband or extra wideband channel. In applying a three-frequency system, the Direct Transfer Trip keying inputs shifts the channel low (i.e.,  $-250$  Hz for 600 Hz bandwidth) and the unblock key shifts the channel high (i.e.,  $+250$  Hz for 600 Hz bandwidth).

See figure 3-18 for a sample schematic.

### 3.3.5 Four-Frequency Systems

The UPLC™ can be purchased with the option of setting it for a four-frequency system. The purpose is to use one PLC channel to perform two independent trips. It is similar to the three-frequency system but is able to key two relaying inputs simultaneously, where as with the three-frequency system, if both inputs are keyed simultaneously, only the DTT frequency is output.

Four frequencies are utilized within either a 600Hz bandwidth or a 1200Hz bandwidth system. For details please refer to the Installation Guide.

Bandwidth/Shift can be 600Hz,  $\pm 250$ Hz or 1,200Hz  $\pm 500$ Hz. The receiver is able to dis-

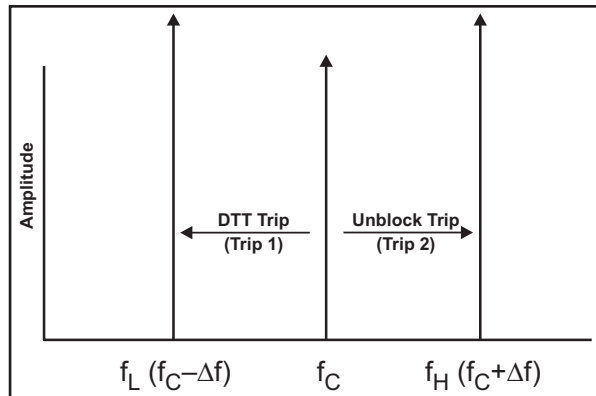

Figure 3-17. UPLC™ 3-Frequency System.

criminate between these four frequencies and provide the necessary input to the logic portion.

The logic is two sets of the full unblock logic. This allows you to select either command function, DTT or Unblock. Should both inputs be keyed simultaneously, the frequency that is sent will engage both Trip A and Trip B outputs.

The trip test feature is not available in the four-frequency system.

### 3.3.6 Three-Terminal Line Applications

When a three terminal line protection requires power line carrier equipment, each terminal must have one transmitter and 2 receivers, since each terminal must receive a signal from each of the 2 other ends of the line. Fig. 3-20 is a representation of the transmitter/receiver complement required to implement a single function: Hybrids or other isolation devices are required between transmitters and transmitters to receivers. See the following section for details.

## 3.4 Hybrid Applications

The purpose of the hybrid is to enable the connection of two or more transmitters together on one coaxial cable without causing intermodulation distortion due to the signal from one transmitter affecting the output stages of the other transmitter. Hybrids are also required between transmitters and receivers, depending on the application. The hybrid circuits can, of course, cause large losses in the carrier path and must be used appropriately.

High/low-pass and band-pass networks may also be used, in some applications, to isolate carrier equipment from each other. Several typical applications of hybrids are shown in the following diagrams, Figures 3-21 through 3-25. A summary of some of the more important application rules are given below:

1. All hybrids in a chain should be resistive type hybrids except the last hybrid, that is, the one connected to the line tuner.
2. The last hybrid in the chain should be the reactance type hybrid or a skewed type.
3. When applying transmitters to reactance type hybrids, the frequency spacing between the widest spaced transmitters is about 4% for frequencies below 50 kHz and 6% for frequencies above 50 kHz. If this rule is not followed then the hybrid cannot be adjusted to provide the best possible isolation between all transmitters.
4. When applying transmitters and receivers to a reactance type hybrid the frequency spacing between the transmitter group and receiver group is of no concern; however, all the transmitter frequencies must meet the frequency spacing rule above. This rule is based on receivers with high input impedance.
5. When the last hybrid is a skewed type then the receiver port should be terminated with a 50Ω resistor to obtain proper isolation.

A few guidelines follow in order of importance:

1. The hybrids should be arranged with the lesser losses in the transmitter path and the greater losses in the receiver path to provide more transmitter signal levels onto the power line.
2. Transmitters that are used with wide bandwidth channels should be arranged with lower losses and those of narrower bandwidths should have the higher losses.
3. Narrow band systems are not as susceptible to noise as wider band systems are, therefore they can tolerate the higher loss.

If possible, transmitters used for common applications should be arranged for equal attenuation.

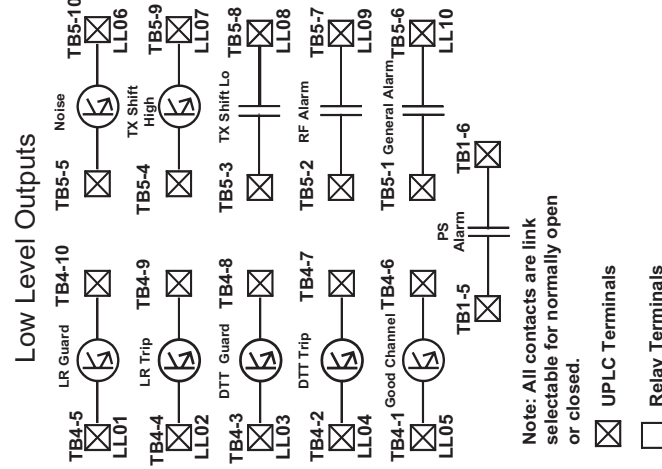
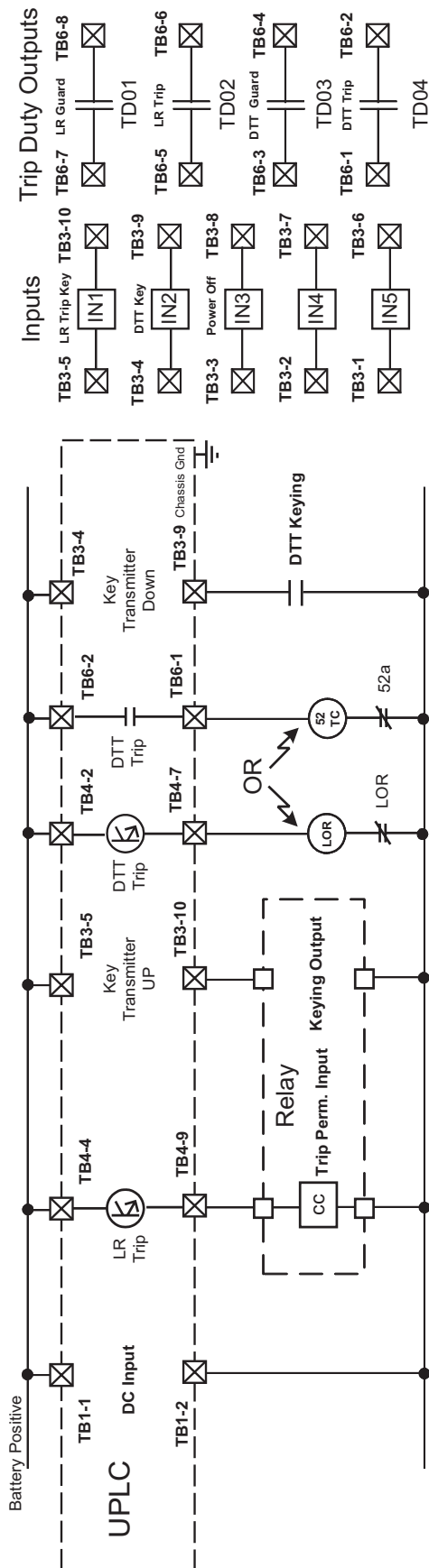

**Jumper Table**

Module	Function	Software Selection	Hardware Selection	Label	Recommendation
Backplane	Coax Setting	JMP3/JMP5	2 wire/4 wire	JMP3/JMP5	4 wire
	# of PAs	JMP2/JMP6	1 PA/2PA	JMP2/JMP6	Per factory
Power Supply	Coax Impedance	JMP1/JMP4	50 Ω/75 Ω	JMP1/JMP4	50 Ω *
	Power	JMP3	PwrOn/PwrOff	JMP3	PwrOn
Input/Output	Alarm Contact	JMP1/JMP2	NO/NC	JMP1/JMP2	Per engineering
	Input 1				Station Battery
Input 2	LR Trip key		15/48/125/250 Vdc	Input 1	Per engineering
Input 3	DTT Key		15/48/125/250 Vdc	Input 2	Per engineering
Input 4	Power Off		15/48/125/250 Vdc	Input 3	Per engineering
Input 5			15/48/125/250 Vdc	Input 4	Per engineering
LL Output 1	LR Guard		15/48/125/250 Vdc	Input 5	Per engineering
LL Output 2	LR Trip	TB4-5 + 10	0.1/1.0 A	LL01	Per engineering
LL Output 3	DTT Guard	TB4-4 + 9	0.1/1.0 A	LL02	0.1 A
LL Output 4	DTT Trip	TB4-3 + 8	0.1/1.0 A	LL03	Per engineering
LL Output 5	Good Channel	TB4-2 + 7	0.1/1.0 A	LL04	1.0 A
LL Output 6	Noise	TB4-1 + 6	0.1/1.0 A	LL05	Per engineering
LL Output 7	TX Shift High	TB5-4 + 9	0.1/1.0 A	LL06	Per engineering
LL Output 8	TX Shift Lo	TB5-3 + 8	NO/NC	LL07	Per engineering
LL Output 9	RF Alarm	TB5-2 + 7	NO/NC	LL08	Per engineering
LL Output 10	General Alarm	TB5-1 + 6	NO/NC	LL09	Per engineering
TD Output 1	LR Guard	TB6-7 + 8	NO/NC	TD01	NO
TD Output 2	LR Trip	TB6-5 + 6	NO/NC	TD02	NO
TD Output 3	DTT Guard	TB6-3 + 4	NO/NC	TD03	NO
TD Output 4	DTT Trip	TB6-1 + 2	NO/NC	TD04	NO

\* Or per engineering's recommendation

Fig. 3-18. Transceiver Unit Connections 3 Freq. Set (Unblock Relaying and Direct Transfer Trip).

Fig. 3-19. Transceiver Unit Connections 4 Freq. Set (Unblock Relaying and Direct Transfer Trip).

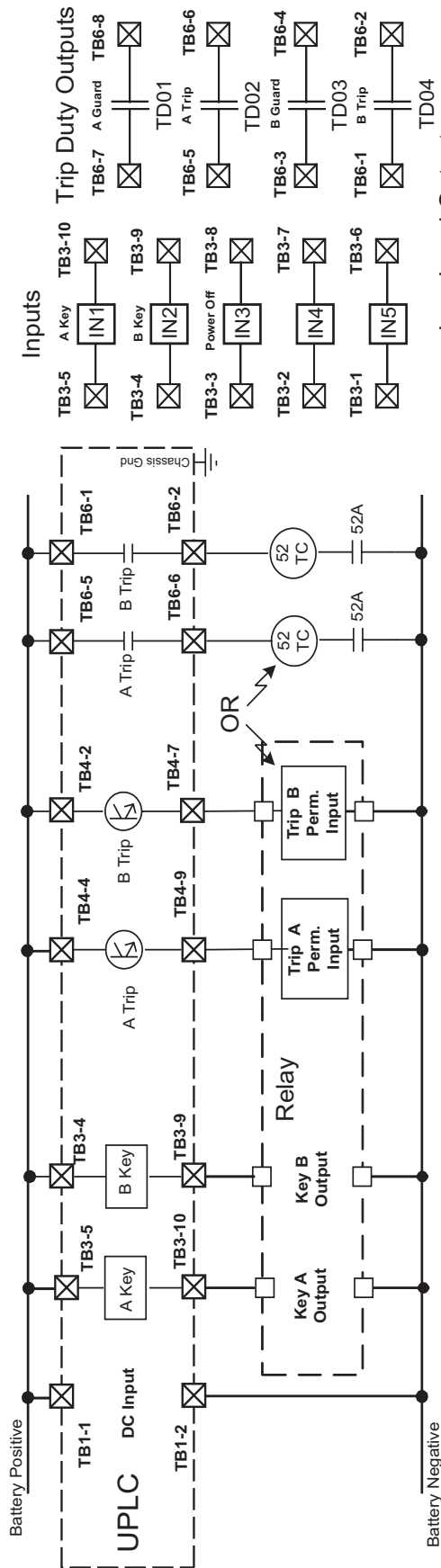

Inputs

Low Level Outputs

Module	Function	Software Selection	Hardware Selection	Label	Recommendation
Backplane	Coax Setting		2 wire/4 wire	JMP3/JMP5	4 wire
	# of PAs		1 PA/2PA	JMP2/JMP6	Per factory
Power Supply	Coax Impedance		50 Ω/75 Ω	JMP1/JMP4	50 Ω *
	Power		PwrOn/PwrOff	JMP3	PwrOn
Input/Output	Alarm Contact		NO/NC	JMP1/JMP2	Station Battery
	A Key		Application of Voltage	Input 1	Per engineering
	B Key		Application of Voltage	Input 2	Per engineering
	Power Off		Application of Voltage	Input 3	Per engineering
				Input 4	Per engineering
LL Output 1	A Guard		15/48/125/250 Vdc	Input 5	Per engineering
LL Output 2	A Trip		15/48/125/250 Vdc	LL01	Per engineering
LL Output 3	B Guard		15/48/125/250 Vdc	LL02	Per engineering
LL Output 4	B Trip		15/48/125/250 Vdc	LL03	Per engineering
LL Output 5	Good Channel		15/48/125/250 Vdc	LL04	Per engineering
LL Output 6	Noise		15/48/125/250 Vdc	LL05	Per engineering
LL Output 7	TX Shift A		15/48/125/250 Vdc	LL06	Per engineering
LL Output 8	TX Shift B		15/48/125/250 Vdc	LL07	Per engineering
LL Output 9	RF Alarm		NO/NC	LL08	Per engineering
LL Output 10	General Alarm		NO/NC	LL09	Per engineering
TD Output 1	A Guard		NO/NC	LL10	Per engineering
TD Output 2	A Trip		NO/NC	TD01	NO
TD Output 3	B Guard		NO/NC	TD02	NO
TD Output 4	B Trip		NO/NC	TD03	NO
			NO/NC	TD04	NO

Jumper Table

Note: All contacts are link selectable for normally open or closed.

UPLC Terminals

Relay Terminals

\* Or per engineering's recommendation

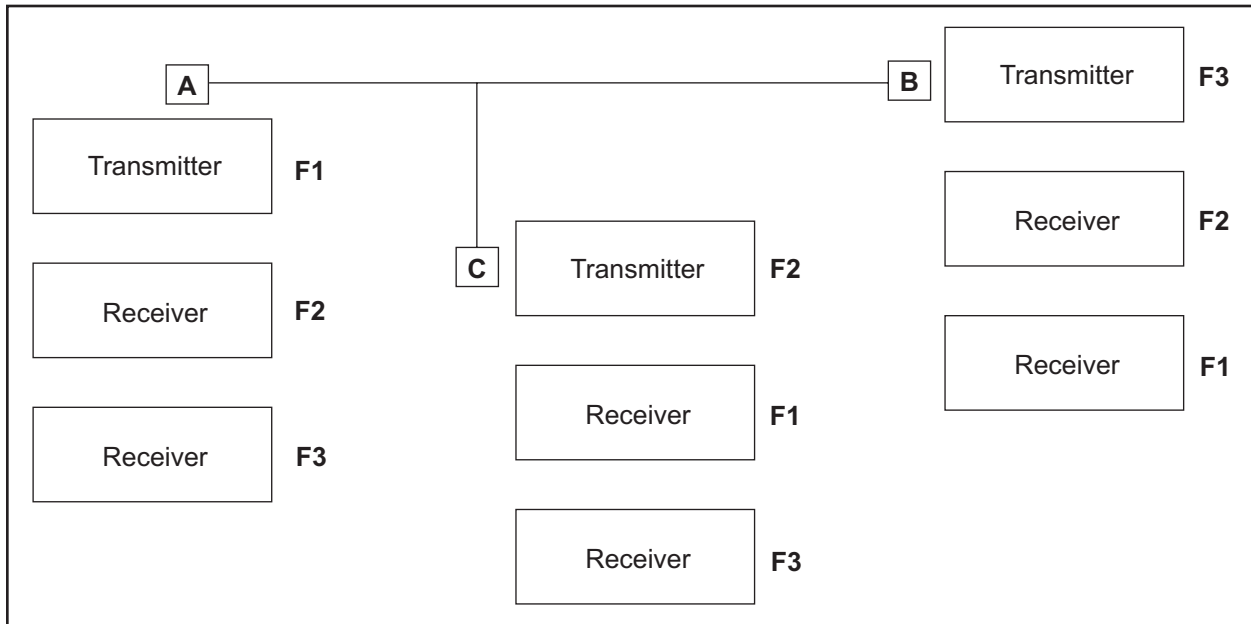

Figure 3–20. Three terminal line application.

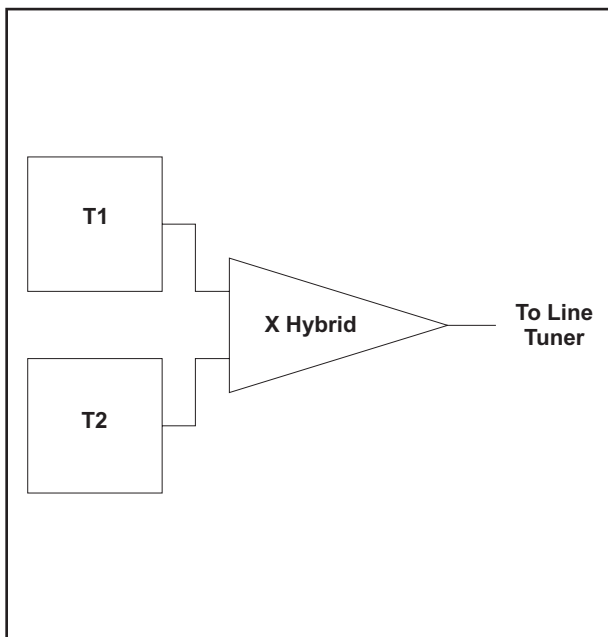

Figure 3–21. Hybrid Connections – Two Transmitters.

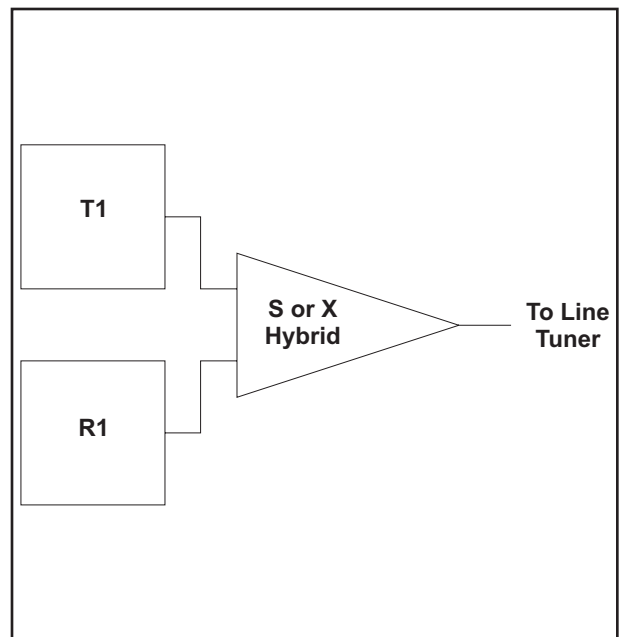

Figure 3–22. Hybrid Connections – Single Bi-Directional Channel.

This would apply to systems that use dual channels such as Direct Transfer Trip (DTT) or Segregated Phase Comparison.

Following are the type of hybrids and their associated style numbers.

### 3.4.1 Examples

Following are several figures that illustrate possible hybrid applications. A short description of each follows.

In these illustrations, Resistive Hybrids are denoted as R hybrids, Reactive hybrids as X hybrids and Skewed hybrids as S hybrids. Fig. 3–21 illustrates two transmitters being combined onto a single coax cable for connection to a line tuner. This would be a typical application for a dual channel, uni-directional trip system. The receive end of the system would not require a hybrid so that the receivers would be tied together via coax cable before connection into the line tuner.

When only one transmitter and one receiver are required as in a single channel bi-directional transfer trip system or a directional comparison

unblocking system Fig. 3–22 can be applied. A skewed hybrid may be used in place of the reactive hybrid (X hybrid). The skewed hybrid has a designated transmit port and receive port.

When two transmitters and two receivers are being applied to a single coax cable, as in a dual channel bi-directional direct transfer trip system, Fig. 3–23 is appropriate.

Four transmitters used for similar applications can be combined as shown in Fig. 3–24. This would be representative of two dual channel uni-directional transfer trip systems. This provides equal losses to each transmitter.

When different types of modulation and different bandwidths are utilized, it is better to arrange the transmitters and receivers as shown in Fig. 3–25. This allocates loss based on performance factors of the modulation type and bandwidth.

Table 3–3. Hybrid Options.

Hybrid Option	Cat. No.	Style No.
• Resistive Hybrid	H1RB	6266D72G05
• Resistive Hybrid (40W)	H1RB-40	6266D72G07
• Skewed Hybrid (50Ω)	H1SB-R	1609C45G03
with terminating resistor		
• Skewed Hybrid (75Ω)		1609C45G01
with terminating resistor		
• Reactance Hybrid	H3XB	6266D71G03
• 19" panel suitable for 3 Hybrids		670B695H01

*For more details, please refer to the Hybrids System manual.*

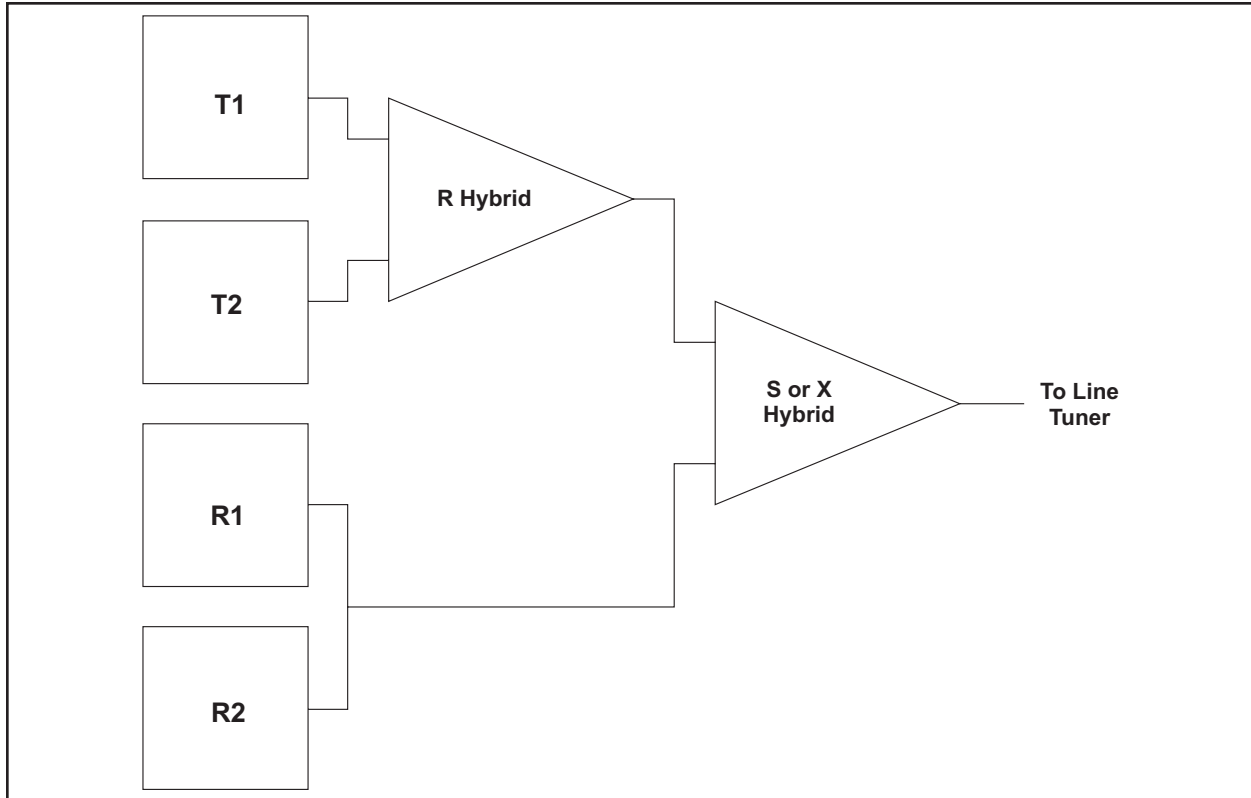

Figure 3–23. Hybrid Connections – Dual Bi-Directional Channel.

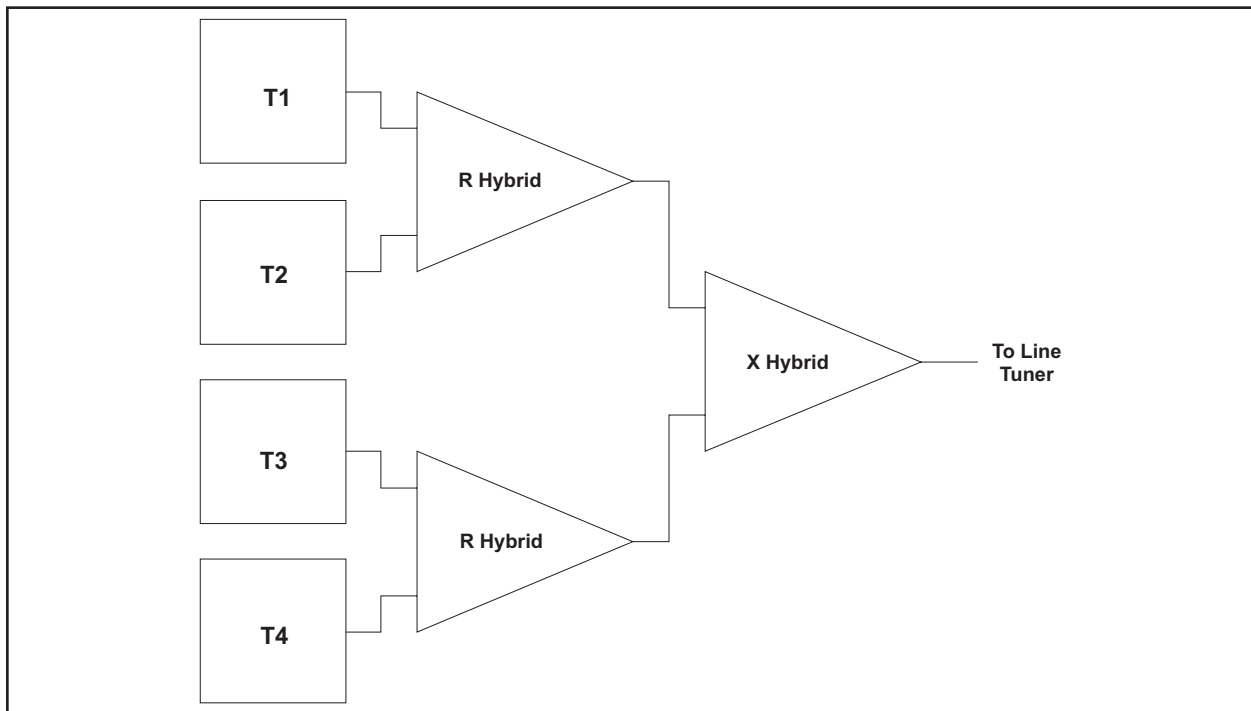

Figure 3–24. Hybrid Connections – Four Transmitters (Equal Losses).  
Two Dual-Channel Uni-Directional Channels.

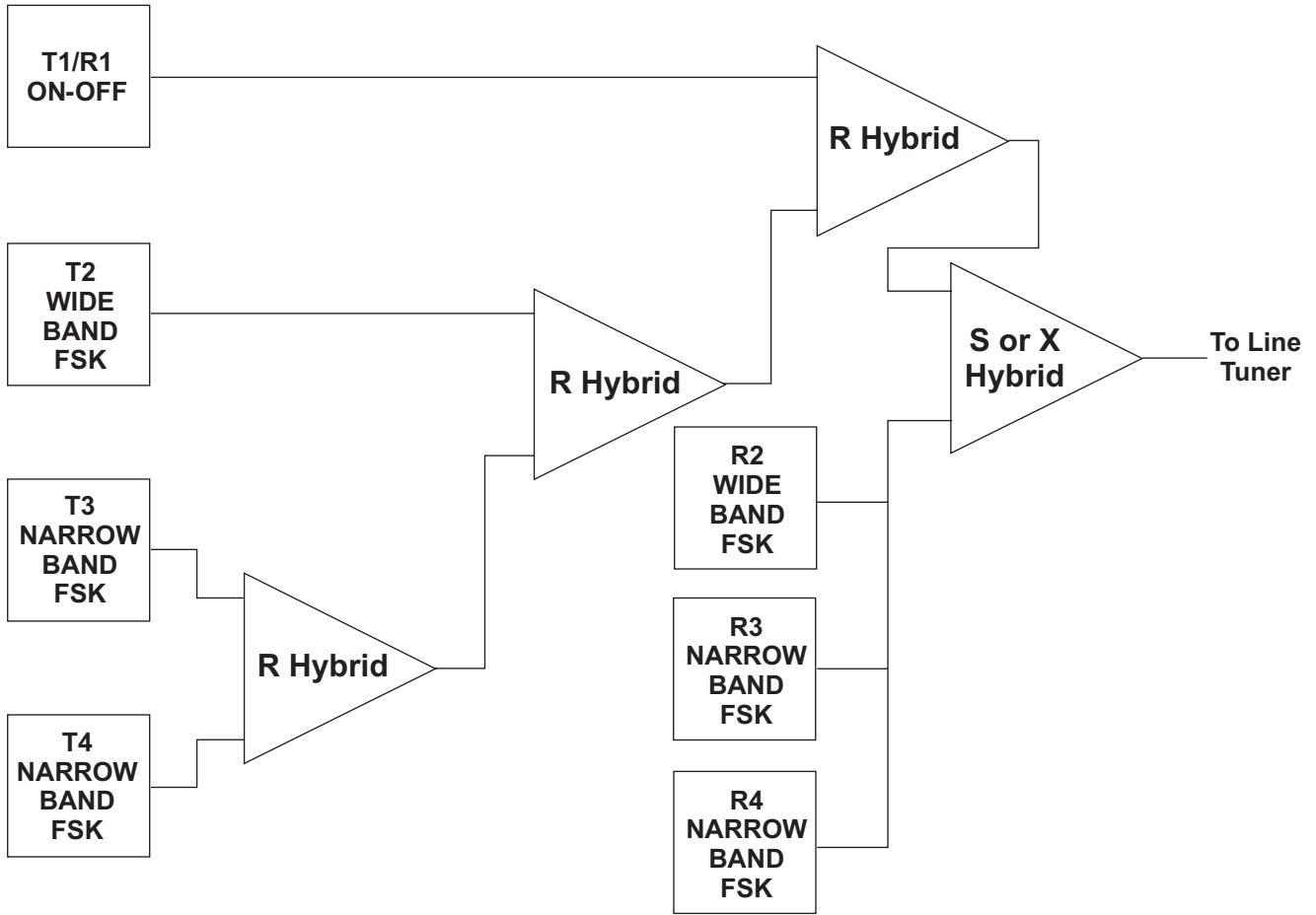

Figure 3–25. Hybrid Connections – (Equal Performances).



## 3.5 Protective Relay Applications Using ON/OFF Carriers

The UPLC™ carrier set is particularly suitable for the following types of protective relay systems:

- Directional-Comparison Blocking
- Phase-Comparison Blocking
- Current Only
- Distance Supervised

### 3.5.1 Directional-Comparison Blocking

The basic elements for directional-comparison blocking systems are shown in Figure 3–26a and Figure 3–26b. At each terminal, the phase and ground trip units (P) must be directional and set to overreach the remote terminal; that is, they must be set to operate for all internal faults. Nominal settings of the distance units are 120 to 150 percent of the line. The start units (S) must reach farther, or be set more sensitively, than the remote trip units. Thus S<sub>1</sub> must be set more sensitively than P<sub>2</sub> or reach farther behind bus G. Likewise, S<sub>2</sub> must be set more sensitively than P<sub>1</sub> or reach farther behind bus H. In any case, the S and P relays should be similar in type. If the trip unit (P) is a directional overcurrent ground relay, the start (S) ground relay should be a similar non-directional overcurrent unit. The same principle applies for the phase relays.

When the UPLC™ is set for ON-OFF power line carrier applications, except for possible auxiliary functions, **no signal is normally transmitted**, since the S units operate only during fault conditions.

Operation of the directional-comparison scheme (shown in Figure 3–26a and Figure 3–26b) is internal faults. Subscript 1 indicates relays at station G for breaker 1; subscript 2, relays at station H for breaker 2. (Figure 3–26c shows a solid-state logic version of Figure 3–26b.)

The schemes shown are still widely used for their flexibility and reliability. Since the communication channel is not required for tripping, internal

faults that might short and interrupt the channel are not a problem. Over tripping will occur, however, if the channel fails or is not established for external faults within the reach of the trip fault detectors. Since the carrier transmitter is normally OFF, or non-transmitting, channel failure cannot be detected until the system is tested or until an external fault occurs. This limitation can be overcome by using the optional checkback system with the UPLC™ carrier.

A sample schematic for the KA-4 relaying system is shown in Figure 3–27. A sample schematic for a basic microprocessor relay system is shown in Figure 3–28. Figures 3–29a, 3–29b & 3–29c illustrate some GE EM relay schematics.

### 3.5.2 Phase-Comparison Blocking

Basic elements of the phase-comparison systems are shown in Figure 3–30. The system uses a composite sequence current network to provide a single-phase voltage output proportional to the positive, negative, and zero sequence current input. Sensitivity to different types of faults depends on the weighting factors or constants designed into the sequence current network. Adjustments to the network are provided.

A squaring amplifier in the controlling relay converts the single-phase voltage output to a square wave. The positive voltage portion corresponds to the positive half-cycle of the filter voltage wave and the zero portion corresponds to the negative half-cycle. The square wave is used to key the UPLC™, transmitting to the remote terminal. The square wave from the remote terminal is compared to the local square wave, which has been delayed by an amount equal to the absolute channel delay time. This comparison of the local and remote square waves at each terminal determines whether a fault is internal or external.

Fault detectors are used to determine whether a fault has occurred and to supervise tripping. The fault detectors must be overreaching, i.e., set sen-

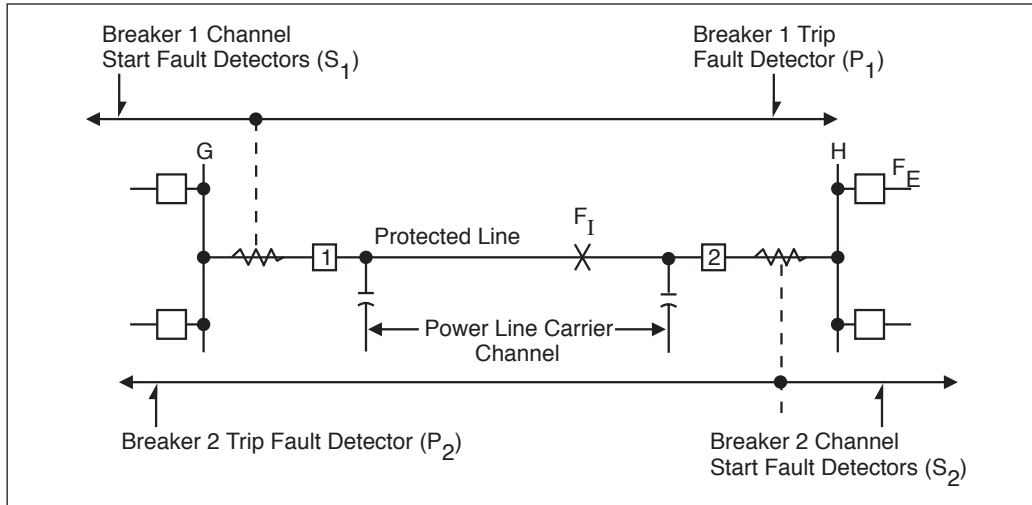

Figure 3-26a – Basic Elements for directional-comparison blocking systems.

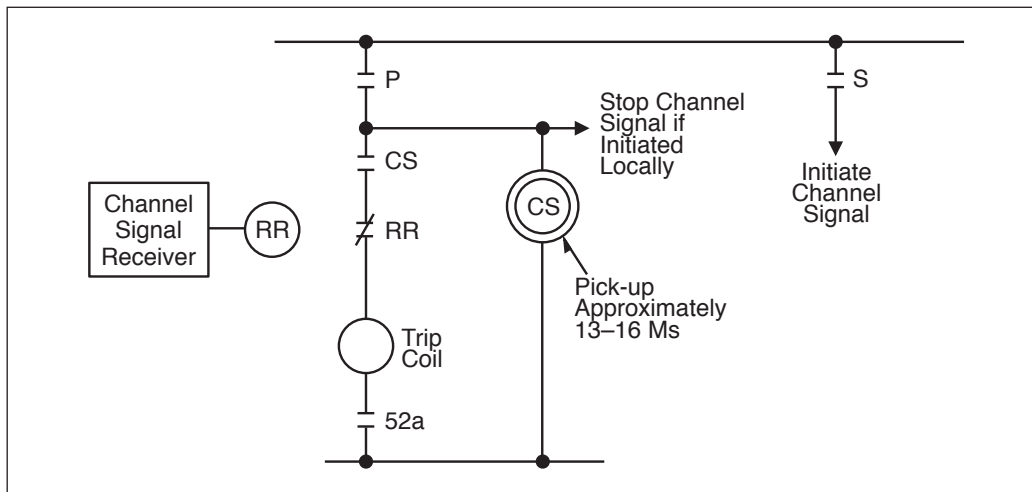

Figure 3-26b – Contact Logic (per Terminal).

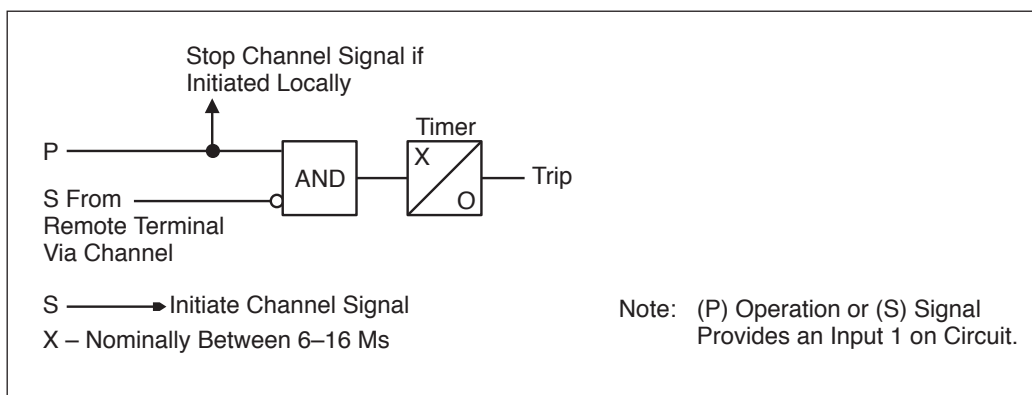

Figure 3-26c – Solid State Logic (per Terminal).

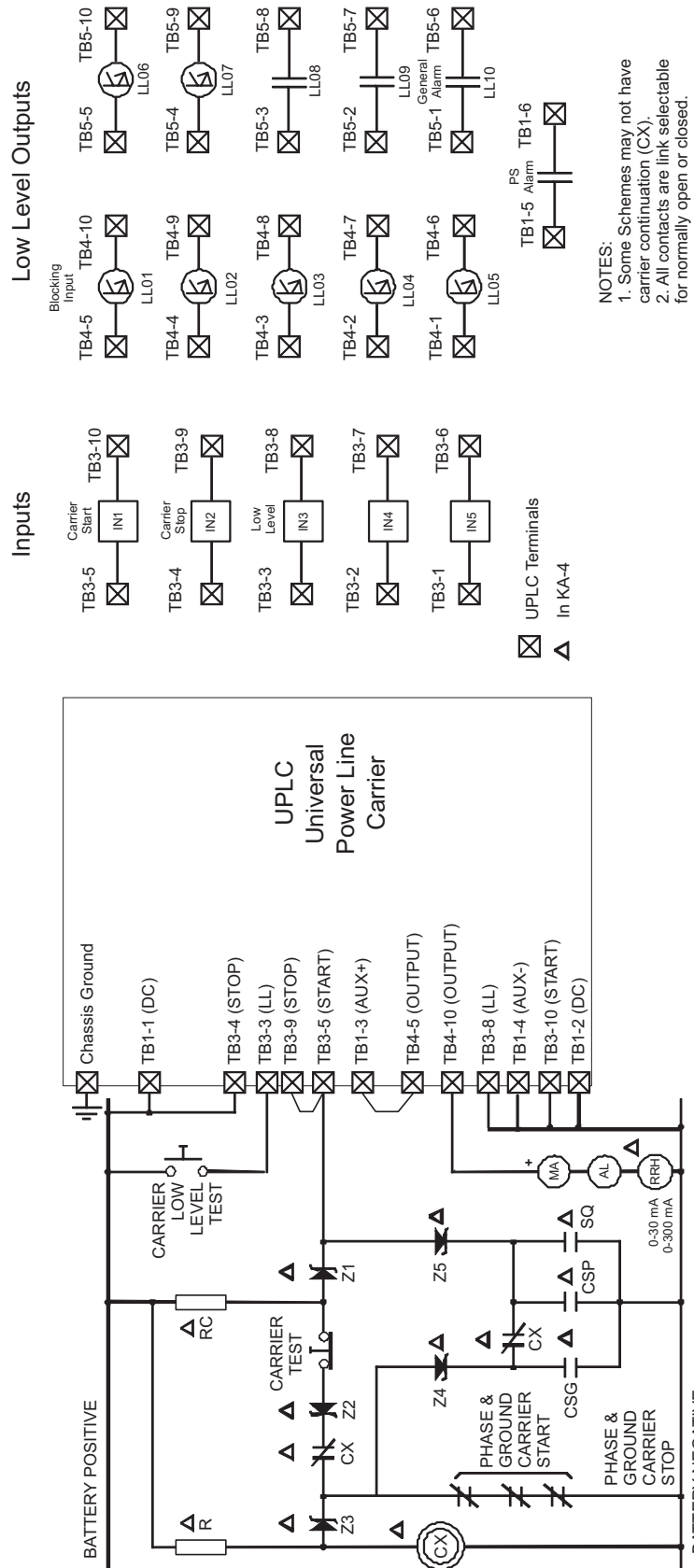

Figure 3-27a. UPLC™ Applied With KA-4 Electromechanical Relay.

Figure 3–27b. UPLC™ Applied With KA-4 Electromechanical Relay.

Conditions of UPLC inputs for use with KA4 electromechanical relay (Stop Priority)				
Condition	Carrier	Carrier Stop	Idle (no start)	Both start & stop
Voltage across Stop Input	15V	125V	62.5V	125V
Voltage across Start Input	110V	0V	62.5V	0V
Result	Start Carrier	Stop Carrier	Stop Carrier	Stop Carrier

Programming /Jumper Table

Module	Function	Software Selection	Hardware Selection	Label on board	Recommendation
Backplane	Coax Setting		2 wire/4 wire	JMP3/JMP5	2 Wire
	# of PAs		1 PA/2PA	JMP2/JMP6	Per factory
Power Supply	Coax Impedance		50/75 ohms	JMP1/JMP4	50 ohms*
	Power		PwrOn/ PwrOff	JMP3	PwrOn
Aux Power Supply	Alarm Contact		NO/NC	JMP1/JMP2	Per Engineering
	Holding current		20 mA/200 mA	8V(200 mA) or 46/20V(20 mA)	JMP1/JMP2 Per carrier relay requirement (JMP3 is used only for 46/20V outputs when JMP1/JMP2 is in '46/20V' position)
Logic	Common Start/Stop Keying Input	Enable			
Input/Output	Input 1	Carrier Start	Application of Voltage	Input 1	Set to voltage setting one step below station battery, ie - 125 Vdc battery, use 48 volt jumper
	Input 2	Carrier Stop	Application of voltage	Input 2	Set to voltage setting one step below station battery, ie - 125 Vdc battery, use 48 volt jumper
	Input 3	Low Level Key	15/48/125/250 Vdc	Input 3	Per Engineering
	Input 4		15/48/12 5/250 Vdc	Input 4	Per Engineering
	Input 5		15/48/125/250 Vdc	Input 5	Per Engineering
	LL Output 1	Blocking Output	(NO)	LL01	1.0 A
	LL Output 2		0.1/1.0 A	LL02	Per Engineering
	LL Output 3		0.1/1.0 A	LL03	Per Engineering
	LL Output 4		0.1/1.0 A	LL04	Per Engineering
	LL Output 5		0.1/1.0 A	LL05	Per Engineering
	LL Output 6		0.1/1.0 A	LL06	Per Engineering
	LL Output 7		0.1/1.0 A	LL07	Per Engineering
	LL Output 8		NO/NC	LL08	Per Engineering
	LL Output 9		NO/NC	LL09	Per Engineering
	LL Output 10	General Alarm	NO/NC	LL10	Per Engineering

\* Or per engineering's recommendation

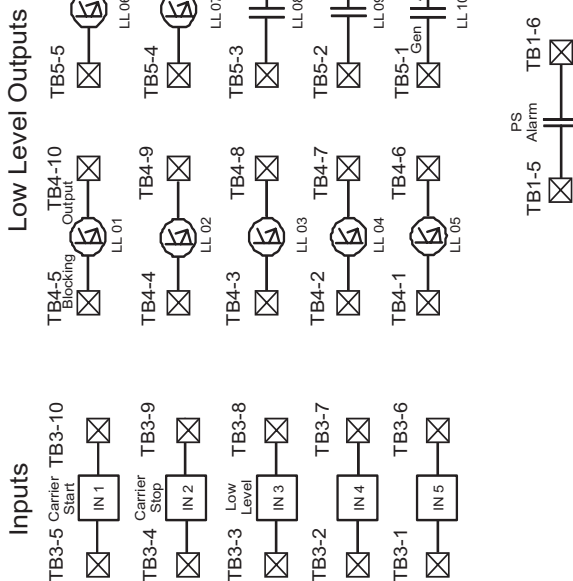
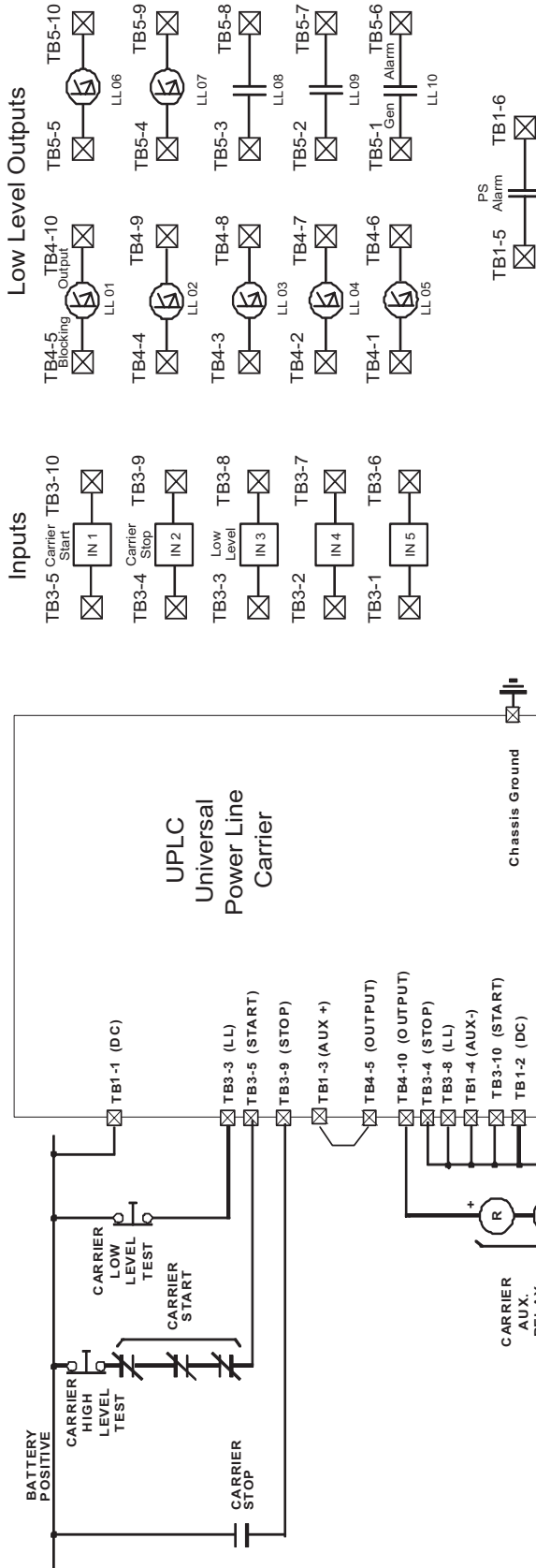

NOTES:  
1. All contacts are link selectable for normally open or closed.

**Jumper Table**

Module	Function	Software Selection	Hardware Selection	Label on board	Recommendation
Backplane	Coax Setting		2 wire/4 wire	JMP3/JMP5	2 Wire
	# of PAs		1 PA/2PA	JMP2/JMP6	Per factory
	Coax Impedance		50/75 ohms	JMP1/JMP4	50 ohms*
Power Supply	Power		PwrOn/ PwrOff	JMP3	PwrOn
	Alarm Contact		NO/NC	JMP1/JMP2	Per Engineering
Aux Power Supply	Holding current		20 mA/200 mA	8V/200 mA) or 46/20V(20 mA)	JMP1/JMP2 Per carrier relay requirement (JMP3 is used only for 46/20V outputs when JMP1/JMP2 is in 46/20V position)
Input/Output					
Input 1	Carrier Start	Removal of Voltage	15/48/125/250 Vdc	Input 1	Station Battery
Input 2	Carrier Stop	Application of Voltage	15/48/125/250 Vdc	Input 2	Station Battery
Input 3	Low Level Key	Removal of Voltage	15/48/125/250 Vdc	Input 3	Station Battery
Input 4				Input 4	Per Engineering
Input 5				Input 5	Per Engineering
LL Output 1				LL01	1.0 A
LL Output 2				LL02	Per Engineering
LL Output 3				LL03	Per Engineering
LL Output 4				LL04	Per Engineering
LL Output 5				LL05	Per Engineering
LL Output 6				LL06	Per Engineering
LL Output 7				LL07	Per Engineering
LL Output 8				LL08	Per Engineering
LL Output 9				LL09	Per Engineering
LL Output 10	General Alarm	(NO)	NO/NC	LL010	Per Engineering

\* Or per engineering's recommendation

Fig. 3-28. UPLC™ Programmed as ON/OFF (AM) PLC Channel (Standard Configuration).

Figure 3–29a. GE Type EM Relays with UPLC™

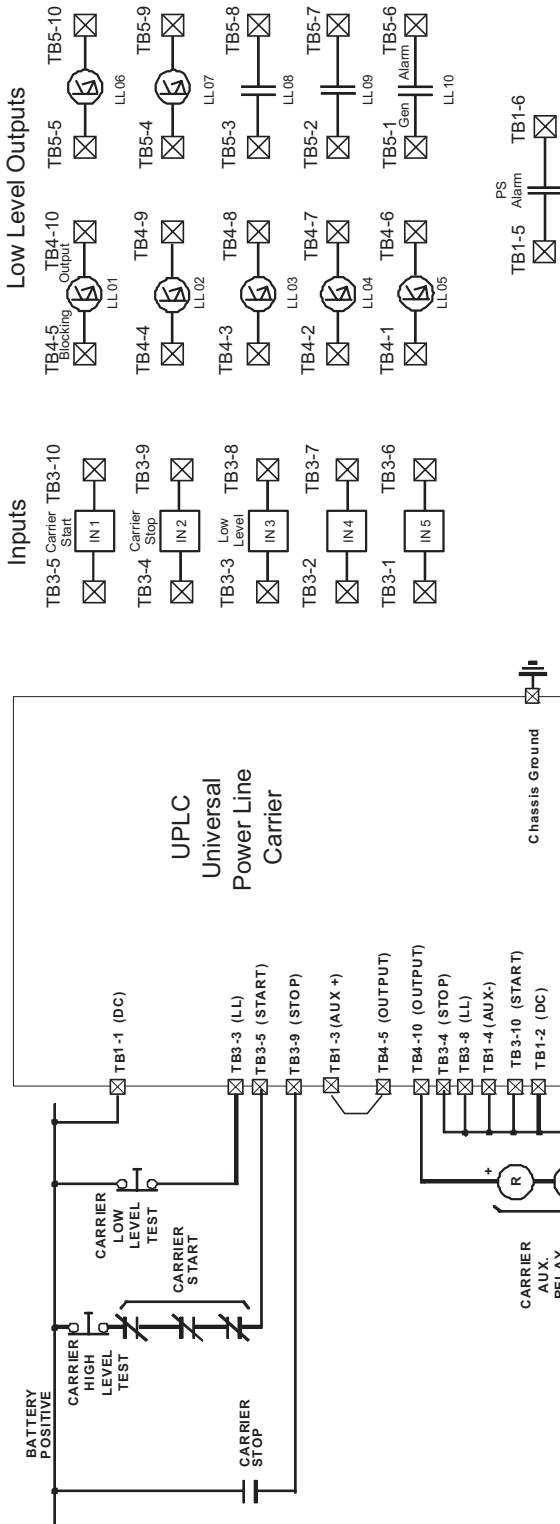

NOTES:  
1. All contacts are link selectable for normally open or closed.

Jumper Table

Module	Function	Software Selection	Hardware Selection	Label on board	Recommendation
Backplane	Coax Setting		2 wire/4 wire	JMP3/JMP5	
	# of PAs		1 PA/2PA	JMP2/JMP6	Per factory
Power Supply	Coax Impedance		50/75 ohms	JMP1/JMP4	50 ohms*
	Power		PwrOn/ PwrOff	JMP3	PwrOn
Aux Power Supply	Alarm Contact		NO/NC	JMP1/JMP2	Per Engineering
	Holding current		20 mA/200 mA	8V(200 mA) or 46/20V(20 mA)	JMP1/JMP2 Per carrier relay requirement (JMP3 is used only for 46/20V outputs when JMP1/JMP2 is in 46/20V position)
Input/Output	Carrier Start	Removal of Voltage	15/48/125/250 Vdc	Input 1	Station Battery
	Carrier Stop	Application of Voltage	15/48/125/250 Vdc	Input 2	Station Battery
	Low Level Key	Removal of Voltage	15/48/125/250 Vdc	Input 3	Station Battery
			15/48/125/250 Vdc	Input 4	Per Engineering
			15/48/125/250 Vdc	Input 5	Per Engineering
LL Output	LL Output 1		0.1/1.0 A	LLO1	1.0 A
	LL Output 2		0.1/1.0 A	LLO2	Per Engineering
	LL Output 3		0.1/1.0 A	LLO3	Per Engineering
	LL Output 4		0.1/1.0 A	LLO4	Per Engineering
	LL Output 5		0.1/1.0 A	LLO5	Per Engineering
	LL Output 6		0.1/1.0 A	LLO6	Per Engineering
	LL Output 7		0.1/1.0 A	LLO7	Per Engineering
	LL Output 8		NO/NC	LLO8	Per Engineering
	LL Output 9		NO/NC	LLO9	Per Engineering
	LL Output 10	General Alarm	(NO)	NO/NC	LLO10

\* Or per engineering's recommendation

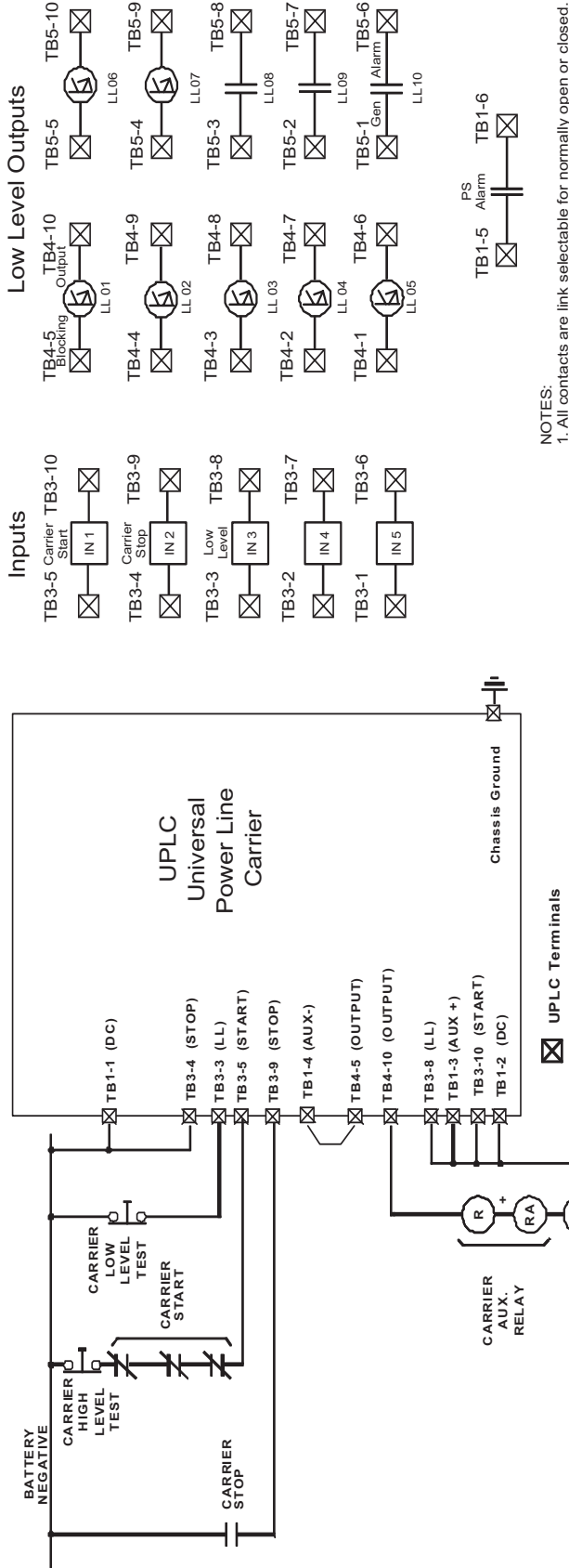
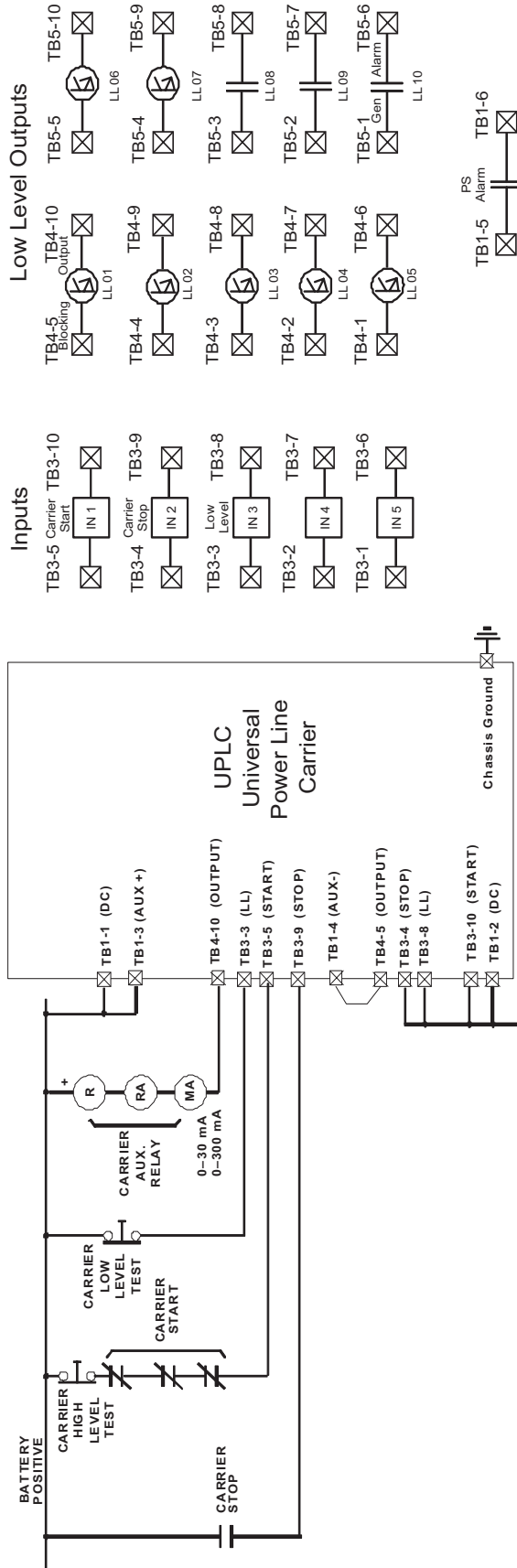

Figure 3-29b. GE Type EM Relays with UPLC™.

Figure 3–29c. GE Type EM Relays with UPLC™



NOTES:  
1. All contacts are link selectable for normally open or closed.

**UPLC Terminals**  
**Jumper Table**

Module	Function	Software Selection	Hardware Selection	Label on board	Recommendation
Backplane	Coax Setting		2 wire/4 wire	JMP3/JMP5	2 Wire
	# of PAs		1 PA/2PA	JMP2/JMP6	Per factory
Power Supply	Coax Impedance		50/75 ohms	JMP1/JMP4	50 ohms*
	Power		PwrOn/ PwrOff	JMP3	PwrOn
	Alarm Contact		NO/NC	JMP1/JMP2	Per Engineering
Aux Power Supply	Holding current		20 mA/200 mA	8V(200 mA) or 46/20V(20 mA)	JMP1/JMP2 Per carrier relay requirement (JMP3 is used only for 46/20V outputs when JMP1/JMP2 is in 46/20V position)
Input/Output					
Input 1	Carrier Start	Removal of Voltage	15/48/125/250 Vdc	Input 1	Station Battery
Input 2	Carrier Stop	Application of Voltage	15/48/125/250 Vdc	Input 2	Station Battery
Input 3	Low Level Key	Removal of Voltage	15/48/125/250 Vdc	Input 3	Station Battery
Input 4			15/48/125/250 Vdc	Input 4	Per Engineering
Input 5			15/48/125/250 Vdc	Input 5	Per Engineering
LL Output 1	Blocking	NO	0.1/1.0 A	LL01	1.0 A
LL Output 2			0.1/1.0 A	LL02	Per Engineering
LL Output 3			0.1/1.0 A	LL03	Per Engineering
LL Output 4			0.1/1.0 A	LL04	Per Engineering
LL Output 5			0.1/1.0 A	LL05	Per Engineering
LL Output 6			0.1/1.0 A	LL06	Per Engineering
LL Output 7			0.1/1.0 A	LL07	Per Engineering
LL Output 8			NO/NC	LL08	Per Engineering
LL Output 9			NO/NC	LL09	Per Engineering
LL Output 10	General Alarm	NO	NO/NC	LL010	Per Engineering

\* Or per engineering's recommendation



Table 3–4. Directional Comparison Schemes for External and Internal Faults.

SCHEME FOR EXTERNAL AND INTERNAL FAULTS		
Type of Fault	Events at Station G	Events at Station H
External ( $F_E$ ) For external faults, the CS unit or timer x/o assure that a blocking signal is established.	$P_1$ operates; $S_1$ does not see fault. Blocking signal received from station H. RR back contacts open (or 1 signal negates AND). No trip.	$S_2$ operates to key transmitter. Blocking signal sent to station G. $P_2$ does not see fault. No trip.
Internal ( $F_I$ )	$P_1$ operates; $S_1$ may or may not operate, but $P_1$ operation prevents transmission of a blocking signal. Breaker 1 tripped.	$P_2$ operates, $S_2$ may or may not operate but $P_2$ operation prevents transmission of a blocking signal. Breaker 2 tripped.

\* For external faults, the CS unit or timer x/o assure that a blocking signal is established.

sitively enough to operate for all internal phase and ground faults.

Because overcurrent fault detectors are normally used, voltage transformers are not required. Such a scheme is current only. Fault detectors should be set above maximum load, yet operate for all internal faults. Distance fault detectors, which require voltage transformers, are used on heavy-loaded or long lines when distance supervision is required.

### 3.5.3 Single Phase-Comparison Blocking, Current Only

In the current only system, the UPLC™ is used with two overcurrent fault detectors (FD1 and FD2). FD1, the carrier start unit, is set more sensitively than FD2 and permits the local square wave signal to key the “ON/OFF” carrier transmitter. FD2, set with a higher pickup than FD1, is used to arm the system for tripping. For transmission lines less than 100

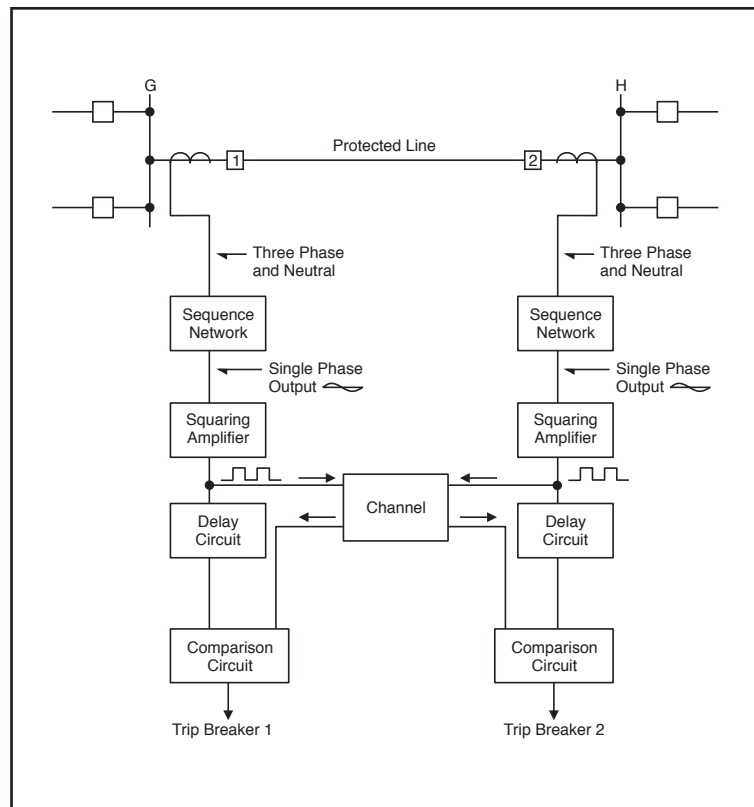

Figure 3–30 Phase-Comparison Blocking, Basic Elements.

miles long, the FD2 pickup is set at 125 percent of FD1. For lines longer than 100 miles, the FD2 pickup is set at 200 percent of FD1. On a three-terminal line, FD2 is set at 250% of FD1, provided the line length between any two breakers is less than 100 miles. Phase-Comparison cannot occur until FD2 operates. The purpose of the two fault detectors is to coordinate the comparison of the local and remote square waves with the keying of the carrier square wave. **The carrier must be started before the comparison is allowed** to ensure that the remote square wave has been received.

The basic operation of the system is shown in Figure 3–28. FD<sub>1</sub> and FD<sub>2</sub> at both terminals operate for an internal fault (F<sub>I</sub>). The square wave inputs to the AND from the local currents are essentially in phase with those transmitted via the channel from the remote terminal. The local square wave turns the carrier “ON” and “OFF” to provide the square wave receiver output for the remote terminal.

A flip flop is energized if the inputs to the AND continue for 4ms, providing a continuous trip output supervised by FD2 operation. The 4ms correspond to a phase angle difference of 90°, on a 60-Hz base, between the currents at the two terminals. The currents at the two ends of the line may be out of phase by up to 90° and still trip. This is a blocking system, since the receipt of a signal from the channel prevents tripping. The carrier signal, therefore, does not have to be transmitted through the internal fault. No received signal puts a “1” on the AND input. With the remote termi-

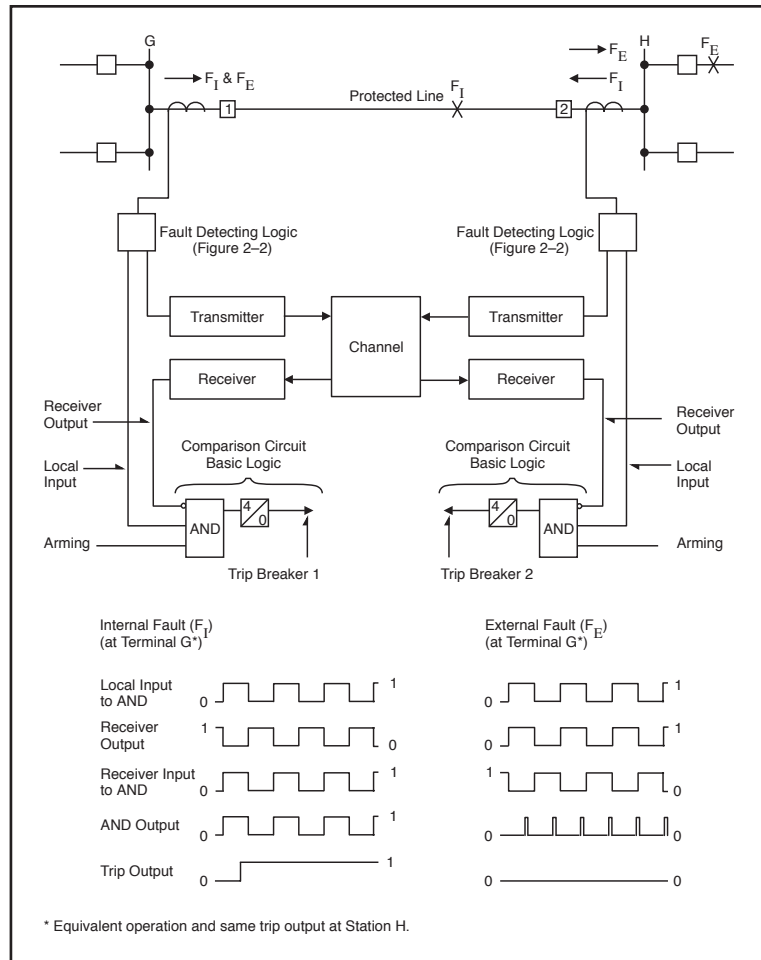

Figure 3–31. Single Phase Comparison Blocking, Current Only Operation.

nals open, this system provides sensitive instantaneous overcurrent protection for the entire line. As is characteristic of blocking systems, the channel is not required for tripping on internal faults.

For an external fault, such as F<sub>E</sub> in Figure 3–31, blocking is essentially continuous, since the remote wave input to the AND is out-of-phase with the local square wave. The secondary ct currents are essentially out-of-phase for an external fault. The currents can, however, be in-phase by up to 90° on a 60-Hz base and still block.

### 3.5.4 Single-Phase, Distance-Supervised Comparison Blocking

A distance-supervised scheme should be used if the minimum internal three-phase fault current is less than twice the maximum load current. Twice maximum load current allows FD<sub>1</sub> to operate positively on the minimum internal three-phase fault, yet

reset when an external fault is followed by a maximum load current flowing through the line. The UPLC™ operates in the same manner as when used with the current-only scheme, except for the fault detection and arming techniques.

Two sequence current networks and two distance relays supplement the two overcurrent fault detectors.

One sequence current network responds only to negative and zero sequence currents, detecting all phase-to-phase and ground faults (but not three-phase faults). The output of this adjustable network operates the conventional overcurrent FD<sub>1</sub> and FD<sub>2</sub> fault detectors. The two distance relays operate only for three-phase faults. Thus, FD<sub>2</sub> provides the arming function for all unbalanced phase and ground faults, through the adjustable filter, and one of the distance relays (21P) provides arming for all three-phase faults.

The second and non-adjustable sequence current network operates through the squaring amplifier, providing the local square wave and the carrier-keyed square wave required for phase comparison. This signal is keyed by FD<sub>1</sub> and the second distance relay (21S) to provide the carrier start functions. This second network responds to positive, negative, and zero sequence currents. Separate networks provide greater sensitivity: with phase-to-phase faults, for example, more than twice the sensitivity is gained.

The setting coordination of FD<sub>1</sub> and FD<sub>2</sub> overcurrent units is the same as for the current-only system. Settings for the two three-phase distance units are shown in Figure 3–32. Both 21S and 21P distance relays must be set to overreach both the local and remote terminal buses; 21S must be set further than 21P, as shown.

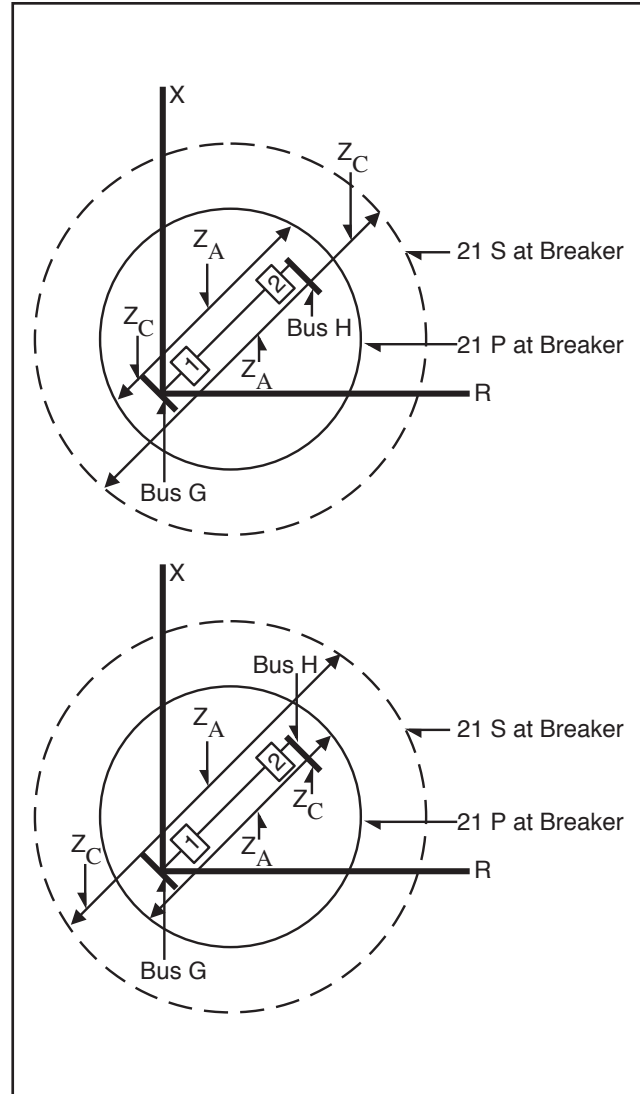

Figure 3–32. Single Phase-Comparison Blocking, Distance-Supervised Operation.

### 3.6 Special Application Considerations

Because the UPLC™ is “ON/OFF” modulated, only one frequency ( $f_C$ ) is required for line protection. When applied to **three terminal lines**, phase cancellation will occur when two or more transmitters are keyed simultaneously. To prevent this, you should offset transmitters by  $\pm 100\text{Hz}$ , using the thumbwheel frequency programming switches. The three frequencies should be:

- $f_C$
- $f_C - 100\text{Hz}$
- $f_C + 100\text{Hz}$

The UPLC™ does not have an adjustable filter or hybrid attached to the output of the transmitter.

If you are using the UPLC™ in an ON-OFF application where no other power line carrier equipment is attached to the power line, then no further action is required. **However, in the application of Single Comparator Phase Comparison relaying, the UPLC™ is to be operated in the four-wire mode, with an external skewed hybrid between transmitter and receiver.**

If you are applying the carrier set with other transmitters, coupled through the same tuning equipment, you must apply a hybrid or a series LC unit to the transmitter output to isolate the other transmitters from the UPLC™ transmitter. This will avoid the problems of intermodulation distortion. We suggest that you use a hybrid if the frequency spacing between all transmitters is within the bandwidth of the hybrid (usually 6%). Check the manufacturers instructions for the actual spacing limitations of the hybrid you are using. If you cannot use a hybrid, then you may use a series LC unit to isolate the transmitters. In this case, the transmitters must have spacing such that the LC you are using will attenuate the external frequencies by at least 20dB (if the other frequency is a 10 watt transmitter), and 30dB (if the other frequency is a 100 watt transmitter).

## Chapter 4. Test Equipment

Table 4–1 shows the equipment you use to verify and/or test your UPLC™ unit.

Table 4–1. Recommended Test Equipment.

Equipment	Application
High-Impedance Selective Level Meter, 380 Hz to 1 MHz (Rycom 6021A) <sup>1</sup>	Impedance Matching Transmitter Power Verification Receiver Margin Verification
Reflected Power Meter, Auto VLF Power SWR Meter (Signal Crafter 70) <sup>1</sup>	Channel Impedance Matching at Carrier Output
Frequency Counter, 80 MHz (H/P5381A) <sup>1</sup>	Transmitter Frequency Verification
Non-Inductive Resistor, 50 or 75Ω, 25W (Pacific) <sup>1</sup>	Transmitter Termination
Signal Generator (H/P 3325A, Signal Crafter Model 90)	General ac output for lab measurements



### CAUTION

**WE RECOMMEND THAT THE USER OF THIS EQUIPMENT BECOME THOROUGHLY ACQUAINTED WITH THE INFORMATION IN THESE INSTRUCTIONS BEFORE ENERGIZING THE UPLC™ AND ASSOCIATED ASSEMBLIES. YOU SHOULD NOT REMOVE OR INSERT PRINTED CIRCUIT MODULES WHILE THE UPLC™ IS ENERGIZED <sup>2</sup>. ALL INTEGRATED CIRCUITS USED ON THE MODULES ARE SENSITIVE TO AND CAN BE DAMAGED BY THE DISCHARGE OF STATIC ELECTRICITY. YOU SHOULD ALWAYS OBSERVE ELECTROSTATIC DISCHARGE PRECAUTIONS WHEN HANDLING MODULES OR INDIVIDUAL COMPONENTS. FAILURE TO OBSERVE THESE PRECAUTIONS CAN RESULT IN COMPONENT DAMAGE.**

<sup>1</sup> Indicates “or equivalent” of the recommended equipment item.

<sup>2</sup> Except for Power Amp and Power Supply modules.



## Chapter 5. Installation/Configuration Procedure

### NOTE

For in depth details, please refer to the UPLC™ Installation Guide provided with the unit.

### General File Format

Here is an example of a configuration file downloaded from the UPLC™. This is an XML file. The file can be checked with any common XML tools to see if it conforms to XML format rules. It can be edited in any standard text-editing program, however you must be certain not to change any of the XML required format. If you are going to edit the file in a text editor it is important that you understand the format requirements of an XML file.

The file has a main section <UPLC™>, also called the 'root node'. The main section encompasses three major sub-sections;

- <genset> - General Settings
- <logset> - Logic Settings
- <ioset> - Input/Output Settings

The Inputs/Outputs settings also has a three minor sub-sections;

- <inputs> - Inputs
- <tdoutputs> - Trip Duty Outputs
- <lloutputs> - Low Level Outputs

These sections encompass the entire configuration for the UPLC™. Typically this file should be system generated to avoid any typographic and syntax errors. Rather than starting from scratch, it's easier to download from the UPLC™ and create a configuration file first, then edit that before uploading it back to the UPLC™. After uploading you should review the changes on the settings pages to ensure they're correct before locking them in by submitting. The XML configuration file can be loaded into any text editor and the data can be changed. We recommend you familiarize yourself with the nuances of the eXtensible Markup Language (XML Files), prior to attempting any changes to the data in the file. Be careful not to change any file formatting or the file will not load properly.

Following, is an example of the downloaded XML file. The data in the example file is shown in bold for instructional purposes only.

NOTE: It will not and should not be in bold in the downloaded or uploaded file.

```
<?xml version="1.0" encoding="ISO-8859-1"?>
<!--UPLC Configuration for 10.14.3.127 as of Mon
Sep 10 11:17:50 2007-->
<UPLC>
  <system>
    <ppc_version>2.00</ppc_version>
  </system>
  <genset>
    <id_line0>System    ID    text    string
1</id_line0>
    <id_line1>System    ID    text    string
2</id_line1>
    <chan_type>1</chan_type>      // AM - 0 FSK
    - 1
    <functn>1</functn>
    <tx_freq>250.00</tx_freq>
    <rx_freq>252.00</rx_freq>
    <txbwshift mode="FSK">2</txbwshift>
    <rxbwshift mode="FSK">2</rxbwshift>
    <tx_low>1.0</tx_low>
    <tx_hi>10.0</tx_hi>
    <fade_alarm>10</fade_alarm>
    <fade_margin>15</fade_margin>
    <reflpwr>15</reflpwr>

    <shift_up_to_trip_tx>0</shift_up_to_trip_tx>

    <shift_up_to_trip_rx>0</shift_up_to_trip_rx>
    <tx_only>0</tx_only>
    <rx_only>0</rx_only>
  </genset>
  <logset>
```

```

<voice>1</voice>
<ptt_delay1>2</ptt_delay>
<trip_hold1>0</trip_hold1>
<guard_hold1>0</guard_hold1>
<ptt_delay2>30</ptt_delay2>
<trip_hold2>35</trip_hold2>
<guard_hold2>40</guard_hold2>
<unblock_time1>0</unblock_time1>
<unblock_delay1>0</unblock_delay1>
<ttu0>2</ttu0>
<guard_t0>2</guard_t0>
</logset>
<ioset>
<inputs>
<in1_hold>0</in1_hold>
<in1_selection>1</in1_selection>
<in1_active_state>0</in1_active_state>
<in2_hold>0</in2_hold>
<in2_selection>2</in2_selection>
<in2_active_state>0</in2_active_state>
<in3_hold>0</in3_hold>
<in3_selection>0</in3_selection>
<in3_active_state>0</in3_active_state>
<in4_hold>0</in4_hold>
<in4_selection>0</in4_selection>
<in4_active_state>0</in4_active_state>
<in5_hold>0</in5_hold>
<in5_selection>0</in5_selection>
<in5_active_state>0</in5_active_state>
</inputs>
<tdoutputs>
<em1_selection>0</em1_selection>
<em2_selection>0</em2_selection>
<em3_selection>0</em3_selection>
<em4_selection>0</em4_selection>
</tdoutputs>
<lloutputs>
<prog1_selection>1</prog1_selection>
<prog1_active>0</prog1_active>
<prog1_action>0</prog1_action>
<prog2_selection>2</prog2_selection>
<prog2_active>0</prog2_active>
<prog2_action>0</prog2_action>
<prog3_selection>6</prog3_selection>
<prog3_active>0</prog3_active>
<prog3_action>0</prog3_action>
<prog4_selection>7</prog4_selection>

```

```

<prog4_active>0</prog4_active>
<prog4_action>0</prog4_action>
<prog5_selection>0</prog5_selection>
<prog5_active>0</prog5_active>
<prog5_action>0</prog5_action>
<prog6_selection>10</prog6_selection>
<prog6_active>0</prog6_active>
<prog6_action>0</prog6_action>
<prog7_selection>4</prog7_selection>
<prog7_active>0</prog7_active>
<prog7_action>0</prog7_action>
<prog8_selection>0</prog8_selection>
<prog8_action>0</prog8_action>
<prog9_selection>0</prog9_selection>
<prog9_action>0</prog9_action>
<prog10_selection>12</prog10_selection>
<prog10_action>0</prog10_action>
</lloutputs>
</ioset>
</UPLC>

```

## Configuration File Modification

### General Settings

#### System Identification

```

<id_line0>System Identification Line
1</id_line0>
<id_line1>System Identification Line II
</id_line1>

```

These two lines are 40 characters free form text. You are free to enter any text here to identify the system.

#### Channel

```
<chan_type>1</chan_type>
```

This indicates the channel type and is a single digit value.

0 - Configures the system to operate in AM or otherwise called ON/OFF mode

1 - Configures the system for operation in FSK Mode

#### Function

```
<functn>1</functn>
```

Function allows you to choose the function type. This is a number between 0 & 3 depending on the choice of mode.



If the Channel is configured for AM Mode, you can choose from the following types:

- 0 – Phase Comparison
- 1 – Directional Comparison

If the Channel is configured for FSK Mode, you can choose from the following types:

- 0 – Phase Comparison
- 1 – Unblocking-2Frequency
- 2 – POTT/DTT-2Frequency
- 3 - 3-Frequency
- 4 - 4-Frequency

Tx & Rx Frequency

```
<tx_freq>250.35</tx_freq>
<rx_freq>252.55</rx_freq>
```

These are the transmit and the receive frequencies within the range of 30 to 530 kHz in steps of 0.01 kHz, e.g. 250.55 is 250.55 kHz.

Bandwidth

```
<bandwidth>1</bandwidth>
```

Bandwidth is specified as a single digit number:

ON/OFF Mode

- 1 – Sets the bandwidth to 600 Hz.
- 2 – Sets the bandwidth to 1200 Hz.
- 3 – Sets the bandwidth to 4000 Hz.

FSK Mode

This is called the TX Bandwidth-Shift & RX Bandwidth-Shift

- 0 – Sets the bandwidth-shift to 300±100 Hz.
- 1 – Sets the bandwidth-shift to 600±100 Hz.
- 2 – Sets the bandwidth-shift to 600±250 Hz.
- 3 – Sets the bandwidth-shift to 1200±250 Hz.
- 4 – Sets the bandwidth-shift to 1200±500 Hz.

FSK - 3 & 4-Frequency has only

- 0 – Sets the bandwidth-shift to 600±250 Hz.
- 1 – Sets the bandwidth-shift to 1200±500 Hz.

Tx Power

```
<tx_low>1.5</tx_low>
```

```
<tx_hi>9.5</tx_hi>
```

The tx\_hi and tx\_low values must be between 1 & 10 W in steps of 0.1 W, with tx\_low smaller than tx\_hi, e.g. 1.5 specifies 1.5 W.

Fade Alarm

```
<fade_alarm>10</fade_alarm>
```

Fade Alarm is between 1 & 25 dB

Fade Margin

```
<fade_margin>15</fade_margin>
```

Fade Margin is between 1 & 25 dB

## Logic Settings

Pre-trip Delay (Valid for FSK Mode Only)

```
<ptt_delay>30</ptt_delay>
```

Pre-trip Delay is 0 – 30 ms in 1 ms steps.

Trip Hold (Valid for FSK Mode Only)

```
<trip_hold>10</trip_hold>
```

Trip Hold is 0 – 100 ms in 1 ms steps.

Guard Hold (Valid for FSK Mode Only)

```
<guard_hold>15</guard_hold>
```

Guard Hold is 0 – 100 ms in 1 ms steps.

Pre-trip Delay (Valid for FSK Mode Only)

```
<ptt3_delay>30</ptt3_delay>
```

Pre-trip Delay is 0 – 30 ms in 1 ms steps.

Trip Hold (Valid for FSK Mode Only)

```
<trip3_hold>35</trip3_hold>
```

Trip Hold is 0 – 100 ms in 1 ms steps.

Guard Hold (Valid for FSK Mode Only)

```
<guard3_hold>40</guard3_hold>
```

Guard Hold is 0 – 100 ms in 1 ms steps.

Unblock Time (Valid for FSK Mode Only)

```
<unblock_time>20</unblock_time>
```

Unblock Time is 0 – 500 ms in 1 ms steps.

Unblock Delay (Valid for FSK Mode Only)

```
<unblock_delay>25</unblock_delay>
```

Unblock Delay is a number between the range of 0 – 100 ms.

Fade Drop Delay (Valid for AM Mode Only)

`<fade_drop_delay>0</fade_drop_delay>`

Fade Drop Delay is 0 – 15 ms in 1 ms steps

Trip Test (Valid for FSK Mode Only)

`<ttu0>1</ttu0>`

Trip Test is a single digit value. Only 1 or 2 is valid:

1 – Disabled

2 – Enabled

Voice

`<voice>2</voice>`

Voice is a single digit value. Only 1 or 2 is valid:

1 – Beep Disabled

2 – Beep Enabled

Guard Before Trip (Valid for FSK Mode Only)

`<guard_t0>2</guard_t0>`

Guard Before Trip is a single digit value between 1 & 3:

1 – Not Required

2 – Required

3 – Required But With Override

Blocking Priority (Valid for AM Mode Only)

`<blk_pri0>1</blk_pri0>`

Blocking Priority is a single digit value:

1 – Stop

2 – Start

Checkback (Valid for AM Mode Only)

`<checkback0>0</checkback0>`

Checkback is a single digit value. Only 0 or 1 is valid:

0 – Checkback Disabled

1 – Checkback Enabled

## Input/Outputs

Inputs

Contact Bounce

`<in1_hold>1</in1_hold>`

Contact Bounce is between 0 to 15. Each unit denotes 0.5 ms. As an example, 8 would be equal to 4ms.

Selection

`<in1_selection>1</in1_selection>`

Selection is a number between 0 & 8 or 9 depending on the mode:

FSK

0 – Not Used

1 – UB Key

2 – Power Off

3 – Trip Test

4 – 52B

5 – SOE Event 1

6 – SOE Event 2

7 – SOE Event 3

AM

0 – Not Used

1 – Carrier Start

2 – Carrier Stop

3 – Low Level Key

4 – Checkback Reset

5 – Checkback Initiate

6 – SOE Event 1

7 – SOE Event 2

8 – SOE Event 3

9 – Loopback Test

Active State

`<in1_active_state>0</in1_active_state>`

Active State is a single digit value. Only 0 or 1 is valid:

0 – Application of Voltage

1 – Removal of Voltage

Trip Duty Outputs

Selection

`<em1_selection>1</em1_selection>`

Trip Duty Outputs is a single digit value between 0 & 2

FSK

0 – Not Used

1 – Guard

2 – Trip

AM

0 – Not Used

1 – Blocking Output

2 – Fade Alarm

Low Level Outputs

Selection

<prog1\_selection>1</prog1\_selection>

Low Level Outputs is a single or double-digit value between 0 & 11 or 16 depending on the mode:

FSK

Phase Comparison

0 – Not used

1 – Trip Negative

2 – Trip positive

3 – Reflected Power

4 – Main RF Output

5 – Redundant RF Output

6 – Good Channel

7 – Noise

8 – Fade Alarm

9 – TX Shift High

10 – TX Shift Low

11 – General Failure

2F-Unblocking & 2F-POTT/DTT

0 – Not used

1 – Guard

2 – Trip

3 – Reflected Power

4 – Main RF Output

5 – Redundant RF Output

6 – Good Channel

7 – Noise

8 – Fade Alarm

9 – TX Shift High

10 – TX Shift Low

11 – Checkback Trip

12 – General Failure

3-Frequency

0 – Not used

1 – LR Guard

2 – LR Trip

3 – Reflected Power

4 – Main RF Output

5 – Redundant RF Output

6 – Good Channel

7 – Noise

8 – Fade Alarm

9 – TX Shift High

10 – TX Shift Low

11 – LR Checkback Trip

12 DTT Guard

13 DTT Trip

14 DTT Checkback Trip

15 – General Failure

4-Frequency

0 – Not used

1 – A Guard

2 – A Trip

3 – Reflected Power

4 – Main RF Output

5 – Redundant RF Output

6 – Good Channel

7 – Noise

8 – Fade Alarm

9 – TX Shift to A

10 – TX Shift to B

11 – A Checkback Trip

12 B Guard

- 13 B Trip
- 14 B Checkback Trip
- 15 – General Failure

#### AM

- 0 – Not used
- 1 – Blocking Output
- 2 – Fade Alarm
- 3 – Reverse Power
- 4 – Main RF Output
- 5 – Redundant RF Output
- 6 – CB Off
- 7 – CB Passed
- 8 – Carrier Received
- 9 – CB Major Alarm
- 10 – CB Minor Alarm
- 11 – CB Delayed Alarm
- 12 – CB Carrier Recovered
- 13 – CB In Recovery Mode
- 14 – CB Test In Progress
- 15 – CB Auto Test Disabled
- 16 – General Alarm

NOTE: General Alarm is a valid option only for the EM Outputs.

#### De-Energized State

```
<em1_selection>1</em1_selection>
```

De-energized State is a single digit value:

- 0 – Normally Open
- 1 – Normally Closed

## Checkback Configuration

### Module Address

```
<address>0</address>
```

Module Address is a number between 0 and 10. 0 being the Master and 1-10 are Remote Modules

### Primary Communication Mode

```
<prim_comm>1</prim_comm>
```

Primary Communication mode is a single digit value. Only 0 or 1 is valid:

- 1 – Coded Communication Mode
- 0 – Timed Communication Mode

### Auto Tests

```
<auto_test>1</auto_test>
```

Auto tests is a single digit value. Only 0 or 1 is valid:

- 1 – Auto Tests On
- 0 – Auto Tests Off

### Fallback Communication Mode

```
<fallback>0</fallback>
```

Fallback Communication Mode is a single digit value. Only 0 or 1 is valid:

- 1 – Enable Fall back Communication
- 0 – Disable Fall back Communication

### Low Power Tests

```
<low_pwr>0</low_pwr>
```

Low Power Tests is a single digit value. Only 0 or 1 is valid:

- 1 – Enable Low Power Tests
- 0 – Disable Low Power Tests

### Last Module

```
<last_rem>1</last_rem>
```

Last Module is between 1 and 10; up to ten Remote Modules can be assigned.

### Retries

```
<retries>4</retries>
```

Retries is 0 – 15, indicating, up to 15 retries are allowed.

### Interval Type

<int\_type>0</int\_type>

Interval type is a single digit value. Only 0 or 1 is valid:

- 1 – Checkback Hours of the day
- 0 – Periodic checkback select

### Hours Of The Day

(Valid only when ‘Hours of the Day’ is selected)

<time1>5</time1>  
<time2>10</time2>  
<time3>15</time3>  
<time4>20</time4>

Hours of the day 0 – 23 in a 24 hour clock format. This indicates the hours of the day checkback needs to run.

### Periodic Checkback

(Valid only when ‘Checkback Hours’ is selected)

<test\_period>8</test\_period>

Periodic Checkback is 0 – 99. This indicates the number of hours to wait before the next Checkback test will run.

### Carrier Recovery

<reco\_enab>0</reco\_enab>

Carrier Recovery is a single digit value. Only 0 or 1 is valid:

- 1 – Enable Carrier Recovery
- 0 – Disable Carrier Recovery

### Recovery Window

<recovery\_time>10</recovery\_time>

Recovery Window is a number between the range of 0 – 24 hours. It specifies how long a UPLC™ will be in Recovery Mode before indicating a Delayed Alarm.

### Recovery Period

<reco\_time>30</reco\_time>

Recovery Period number between the range of 5 – 60 minutes. It specifies the time between Master initiated Checkback tests when the UPLC™ is in Recovery Mode.

### Loopback Duration

<loop\_time>10</loop\_time>

Loopback Duration is 4 – 60 seconds. It specifies how long a UPLC™ will key its transmitter at high and low power during a Loopback test.

### Synchronize Clock Automatically

<sync\_enab>1</sync\_enab>

Synchronize Clock Automatically is a single digit value. Only 0 or 1 is valid:

- 1 – Enable Automatic Synchronization
- 0 – Disable Automatic Synchronization

In addition to the settings file that may be saved as an XML file for modification and uploading, there is a configuration report file that can be saved that records the settings of the UPLC. A typical file looks like this:

```

||                               UPLC Configuration Report

Software Revision:      2.00
Unit IP:               10.14.3.127
Date/Time:             Mon Sep 10 11:20:23 2007

System ID (Major):     System Identification 1
System ID (Minor):    System Identification 2
  
```

#### General Settings

```

Channel Type:          FSK
Function :             Unblocking - 2F
Transmit Frequency:   252.00 Hz
Receive Frequency:    250.00 Hz
TX Shift-Bandwidth:   600 ± 250
RX Shift-Bandwidth:   600 ± 250
Tx Shift Up to Trip:  Disabled
Rx Shift Up to Trip:  Disabled
Transmit Power Low:   1.0 W
Transmit Power High:  10.0 W
Fade Alarm:           10 dB
Fade Margin:          15 dB
Reflected Power Alarm: 15.0 %
Transmitter:          Enabled
Receiver:             Enabled
  
```

#### Logic Settings

```

Voice:                Beep Disabled
Trip Test:            Enabled
Pre-Trip Delay:       2 ms
Trip Hold:            0 ms
Guard Hold:           0 ms
Guard Before Trip:    Required
Unblock Timer:        0 ms
Unblock Delay:        0 ms
  
```

#### Input Output Settings

##### Inputs

1. Hold: 0.0 ms  
    Selection: UB key  
    Active State: Application of Voltage
2. Hold: 0.0 ms  
    Selection: Power Off  
    Active State: Application of Voltage
3. Hold: 0.0 ms

Selection:	not used
Active State:	Application of Voltage
4. Hold:	0.0 ms
Selection:	not used
Active State:	Application of Voltage
5. Hold:	0.0 ms
Selection:	not used
Active State:	Application of Voltage

Line Relay Settings

Pre-Trip Delay:	0 ms
Trip Hold:	0 ms
Guard Hold:	0 ms
Unblock Timer:	0 ms
Unblock Delay:	0 ms
Guard Before Trip:	Required

Direct Transfer Trip Settings

Pre-Trip Delay:	0 ms
Trip Hold:	0 ms
Guard Hold:	0 ms
Shift to Trip:	Disabled
Guard Before Trip:	Required

Input Output Settings

Inputs

1. Hold:	0.0 ms
Selection:	UB key
Active State:	Application of Voltage
2. Hold:	0.0 ms
Selection:	Power Off
Active State:	Application of Voltage
3. Hold:	0.0 ms
Selection:	Trip Test
Active State:	Application of Voltage
4. Hold:	0.0 ms
Selection:	52B
Active State:	Application of Voltage
5. Hold:	0.0 ms
Selection:	SOE Event 1
Active State:	Application of Voltage

Trip Duty Outputs

1. Selection:	Guard NO Contact
2. Selection:	Guard NO Contact
3. Selection:	Trip NO Contact
4. Selection:	Trip NO Contact

## Power Supply Alarms Contacts

Main Power Supply: Normally Closed  
Redundant Power Supply: Not Installed

## Low Level Outputs

1. Selection: Guard  
De-energized State: NO  
Action: Normal  
Max Load: 1.0A
2. Selection: Trip  
De-energized State: NO  
Action: Normal  
Max Load: 1.0A
3. Selection: Good Channel  
De-energized State: NO  
Action: Normal  
Max Load: 1.0A
4. Selection: Noise  
De-energized State: NO  
Action: Normal  
Max Load: 1.0A
5. Selection: not used  
De-energized State: NO  
Action: Normal  
Max Load: 1.0A
6. Selection: TX Shift Low  
De-energized State: NO  
Action: Normal  
Max Load: 1.0A
7. Selection: Main RF Output  
De-energized State: NO  
Action: Normal  
Max Load: 1.0A
8. Selection: not used  
De-energized State: NO  
Action: Normal
9. Selection: not used  
De-energized State: NO  
Action: Normal
10. Selection: General Alarm  
De-energized State: NO  
Action: Normal



# Chapter 6. Maintenance

When individual module maintenance is required, either at the factory or at the customer installation (beyond the scope of routine alignment), the following procedures are applicable. Very little, if any, modification or repair can be done properly in the field. Therefore it is recommended that you contact the factory for a Repair Material Authorization (RMA).

## 6.1 Precautions When Selecting Test Equipment

(See Chapter 4, Test Equipment for test equipment specifications.)

To prevent damage to solid-state components:

- 1) Use transformer-type signal generators, VTVMs and signal tracers, which isolate the test equipment from the power line. Whenever the test equipment uses a transformerless power supply, use an isolation type transformer. The test equipment ground should be isolated from the ac source ground.
- 2) Use multi-meters with at least 20,000 $\Omega$ s-per-volt sensitivity.

## 6.2 Precautions When Using Test Equipment

1. Use a common ground between the chassis of the test equipment and the transistor equipment.



### CAUTION

**HIGH CURRENTS FROM A LOW-SENSITIVITY METER CAN DAMAGE SOLID STATE DEVICES.**

**METERING TRANSISTOR CIRCUITS CAN CAUSE DAMAGE.**

**FOR EXAMPLE: A BASE-TO-COLLECTOR SHORT DURING TRANSISTOR OPERATION CAN DESTROY THE TRANSISTOR.**

2. When testing transistors and diodes, give special attention to the polarity of the meter leads.

For example: When measuring the forward resistance of a diode using a meter that has the internal battery connected to the metering circuit, be sure that:

- The lead marked ( - ) touches the diode anode.
  - The lead marked (+) touches the diode cathode.
3. When checking circuits with an oscillographic probe, be sure to discharge any built-up capacitive voltage by touching the probe to a ground before touching the circuit.

## 6.3 Periodic Checks

Every 12 months, take the following readings on the UPLC™.

- Transmitted Power Output
- Reflected Power
- Receive Level
- Receive Margin

Additionally, we recommend cleaning & re-adjusting any spark gaps in the channel such as in the tuners and CCVTs.

We recommend that you keep a *log book* as a visible record of periodic checks, as well as a source for indicating any gradual degradation in a unit's performance.

## 6.4 Inspection

A program of routine visual inspection should include:

- Condition of cabinet or other housing
- Tightness of mounting hardware and fuses
- Proper seating of plug-in relays and sub-assemblies
- Condition of internal and external wiring (the location where external wiring enters the cabinet should be sealed)
- Appearance of printed circuit boards and components
- Signs of overheating in equipment:
  - Interference with proper heat dissipation from surfaces
  - Clogged air vents (air filters should be removed and washed out)
- Dust which may cause short circuits

## 6.5 Solid-State Maintenance Techniques

Use the following maintenance techniques when servicing solid state equipment.

### 6.5.1 Preliminary Precautions

1. To avoid damage to circuits and components from a current surge, disconnect power before replacing or removing components or circuits.
2. Before placing new components into a defective circuit, check the circuit so that it cannot damage the new components.



### CAUTION

**WE RECOMMEND THAT THE USER OF THIS EQUIPMENT BECOME ACQUAINTED WITH THE INFORMATION HERE BEFORE ENERGIZING THE UPLC™ AND ASSOCIATED ASSEMBLIES.**

**FAILURE TO OBSERVE THIS PRECAUTION MAY RESULT IN DAMAGE TO THE EQUIPMENT. IT IS POSSIBLE, BUT NOT RECOMMENDED TO REMOVE OR INSERT PRINTED CIRCUIT MODULES WHILE THE UPLC™ IS ENERGIZED. PROPER PRECAUTION CAN PREVENT COMPONENT DAMAGE.**

**ALL INTEGRATED CIRCUITS USED ON THE MODULES ARE SENSITIVE TO AND CAN BE DAMAGED BY THE DISCHARGE OF STATIC ELECTRICITY. BE SURE TO OBSERVE ELECTROSTATIC DISCHARGE PRECAUTIONS WHEN HANDLING MODULES OR INDIVIDUAL COMPONENTS.**

### 6.5.2 Trouble-Detection Sequence

1. Evaluate records of routine alignment.
2. Evaluate any symptoms detected audibly or visually.
3. Replace suspected plug-in components.
4. Further isolation of faults includes:
  - Voltage readings
  - Resistance readings
  - Signal injection
  - Re-alignment
  - Sensitivity measurements
  - Gain measurements
5. Replace suspected faulty components.
6. Check-out and adjust affected circuits.

### 6.5.3 Servicing Components Soldered Directly to Terminals

1. Avoid overheating from soldering by using a low-wattage soldering iron (60W maximum).
2. Make sure there is no current leakage from the soldering iron.

You may use an isolation transformer to prevent current leakage.
3. When soldering leads from transistors or diodes, use heat sinks, e.g., alligator clips.
4. You can remove molten solder from the board with a solder-sucker.
5. When removing a multi-lead component from a printed circuit board, first cut all leads and then remove the leads individually (to prevent overheating). If there are only a few leads, you can use a broad-tip soldering iron.

#### NOTE

It is highly recommended that you do not try to repair or modify modules in the field. Call customer service for an RMA number. 800-85-7275 or +1954-344-9822.

### 6.5.4 Servicing Components Mounted Directly on Heat Sinks

1. Remove the heat sink and bracket from the chassis by loosening the securing devices.
2. Remove the transistor, diode, or other device from the heat sink.
3. When replacing the transistor, diode, or other device, make certain that the device and the heat sink make secure contact for good heat dissipation. Mount a device first on the heat sink, and then on the board. Also, make sure that you replace all insulators, washers, spring washers and other mounting hardware as you originally found them.

We recommend a very light coating of DC-4 (Dow-Corning 4 Compound Silicon Lubricant) in between transistors and diodes that are mounted on heat sinks.

### 6.5.5 Servicing Metal Oxide Semiconductor (MOS) Devices

MOS devices may be vulnerable to static changes. Be sure to observe the special precautions described below both before and during assembly.

Precautions to take before assembly:

- Avoid wearing silk or nylon clothing, as this contributes to static buildup.
- Avoid carpeted areas and dry environments.
- Discharge body static by placing both hands on a metal, earth-grounded surface.

Precautions to take during assembly to avoid the possibility of electrostatic discharge:

- Wear a ground strap during assembly
- Avoid touching electrically-conductive circuit parts by hand
- When removing a module from the chassis, always place it on a conductive surface which is grounded through a resistance of approximately 100 K $\Omega$

- Make sure that all electrically-powered test equipment is properly grounded.

### 6.5.6 Transceiver NOVRAM Battery

A “Battery Failure” event indicates that the Transceiver board’s NOVRAM battery has expired. The battery is a *Dallas Semiconductor DS9034PCX*. And we recommend that you maintain a spare in stock. Some events may be lost if this battery expires. It supplies power to an event buffer.

Replacement consists of removing the plastic cover from U30 on the Transceiver board. You may need to gently pry it off with a small flathead screwdriver. Replace the battery (observing the polarity) and snap the plastic cover back onto U30.

#### NOTE

**Before touching a module with a test probe, connect the ground lead from the test equipment to the module. Always disconnect the test probe before removing the ground lead equipment.**

# Chapter 7. Optional Testing Facilities

Optional tests for the UPLC™, if purchased, are available to perform channel testing. The ON-OFF testing can be automated on a timed basis. The FSK has a manual test.

## ON/OFF Automatic Checkback

### 7.1 General Description

For the system to be fully operational, all terminals must have Checkback facilities, such as;

- UPLC™
- TC-10B w/Universal Checkback
- UCBS (Stand-alone Universal Checkback)

The Automatic Checkback Testing Facility provides various ways to automatically or manually test the carrier channel. Components of the Checkback system include:

- PC for controlling settings and operation
- User selectable encoded or timed carrier operation
- Optional timed communication fallback
- Optional low power tests
- Optional carrier recovery
- Automatic checkback tests done either periodically or at user-specified times
- Loopback test capability
- Remote communications
- Automatic clock synchronization

#### 7.1.1 PC Interface for Controlling Settings & Operation

Please refer to the UPLC™ Installation Guide for details. Although, a sample checkback page and test results are shown in Figures 7-1 & 7-2 respectively.

#### 7.1.2 User Selectable Encoded or Timed Carrier Operation

The Automatic Checkback lets you set your communication to a simple keyed on/off timed carrier or a more powerful encoded data message.

#### 7.1.3 Optional Timed Communication Fallback

The Primary Communication mode is initially used for checkback tests. If the primary mode is "encoded" and it fails and Timed Fallback Communication is enabled, the module attempts one more try using a simple timed communication mode. If that succeeds, the module only issues a minor alarm.

#### 7.1.4 Optional Low Power Tests

When enabled, the Automatic Checkback performs checkback tests at both high and low power. The system issues a minor alarm if only the low power test fails, and a major alarm if the high power test fails.

#### 7.1.5 Optional Carrier Recovery

This mode is to verify that any checkback test failures were legitimate hardware failures and were not caused by a brief noise burst. When enabled, the unit starts "carrier recovery mode" after a failed checkback test. In carrier recovery mode, the "master" initiates a checkback test using a more frequent user interval, for example, every 15 minutes. After three consecutive successful checkback tests, the "master" reverts to normal operation and sets the "successful carrier recovery" output. If three successful consecutive checkback tests fail, the "delayed alarm" output is set. Remotes in carrier recovery mode suspend all checkback tests and wait until they receive three good checkback tests from the "master". At that time they also resume normal operation.

### 7.1.6 Automatic Checkback Tests done Periodically or at User-Specified Times

You can set the "master" to perform automatic checkback tests after the interval you specify has elapsed (e.g., six hours), or up to four specific times each day (e.g., 1:00, 13:00, 5:00, and 23:00). These four times specify the hour during which you want an automatic checkback test to occur.

### 7.1.7 Loopback Test Capability

You can command a distant Automatic checkback system to key its carrier for a duration you specify (e.g., 30 seconds), giving you time to set your local receiver's sensitivity or perform other tasks. Loopback tests are performed at both high and low power. If loopback duration is set to 30 seconds, the carrier is keyed on high power for 30 seconds, then low power for 30 seconds.

### 7.1.8 Remote Communications

You can remotely communicate with a distant Automatic checkback system in the network. This lets you get settings, events and counts, and allows you to change settings, clear events, etc. from a unit many miles away.

### 7.1.9 Automatic Clock Synchronization

When enabled, the "master" checkback synchronizes the clocks of all remotes in the network starting at 12:30 a.m.

### 7.1.10 Available alarms

- Major & Minor alarms
- Delayed alarm
- Test in progress
- Successful test
- Successful carrier recovery
- Disable automatic tests

## 7.2 System Configuration

The simplest network configuration for the Checkback system comprises two terminals: one designated as the master; the other as the remote. The maximum number of terminals you can have in a network depends on their Primary Communication Mode setting. This setting may be either "timed" or "coded". With the "timed" setting, you can have up to five units in a network; one master and four remotes. With the "coded" setting, you can have up to eleven units in a network: one master and ten remotes. (see Figures 7-3 & 7-4)

## 7.3 Rear Panel Connections

### 7.3.1 Checkback Inputs

**CB Test Initiate**—Momentarily closing the input, connected here, initiates a checkback test.

**Loopback Initiate**—Closing the input, connected here, initiates a loopback test.



## CAUTION

Circuit boards can be inserted or removed while the chassis has power supplied to it. However, extreme care should be exercised when inserting or removing them.

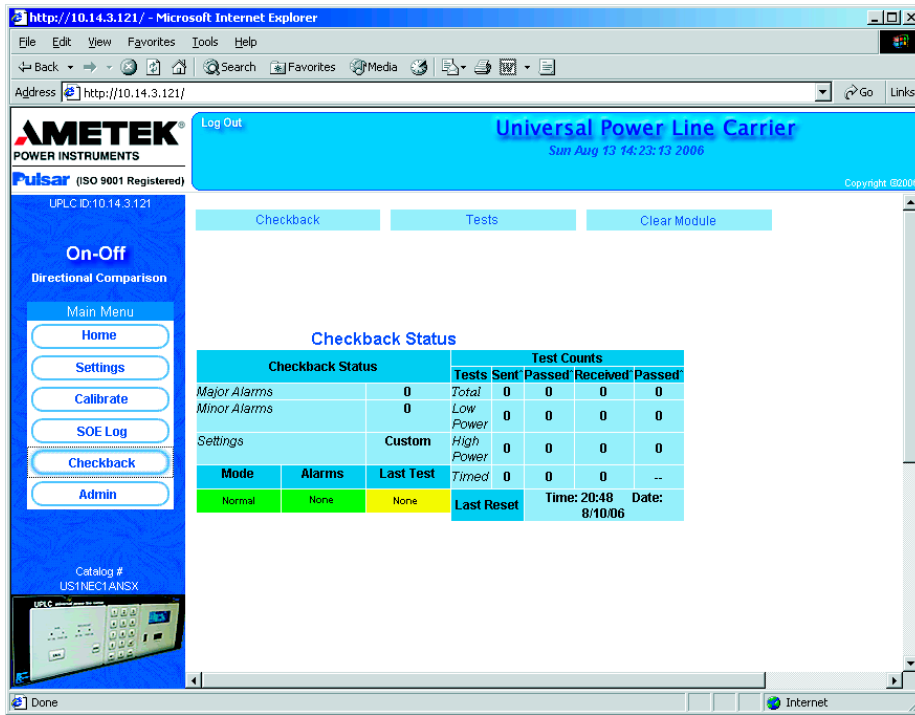

Figure 7-1. Checkback Page.

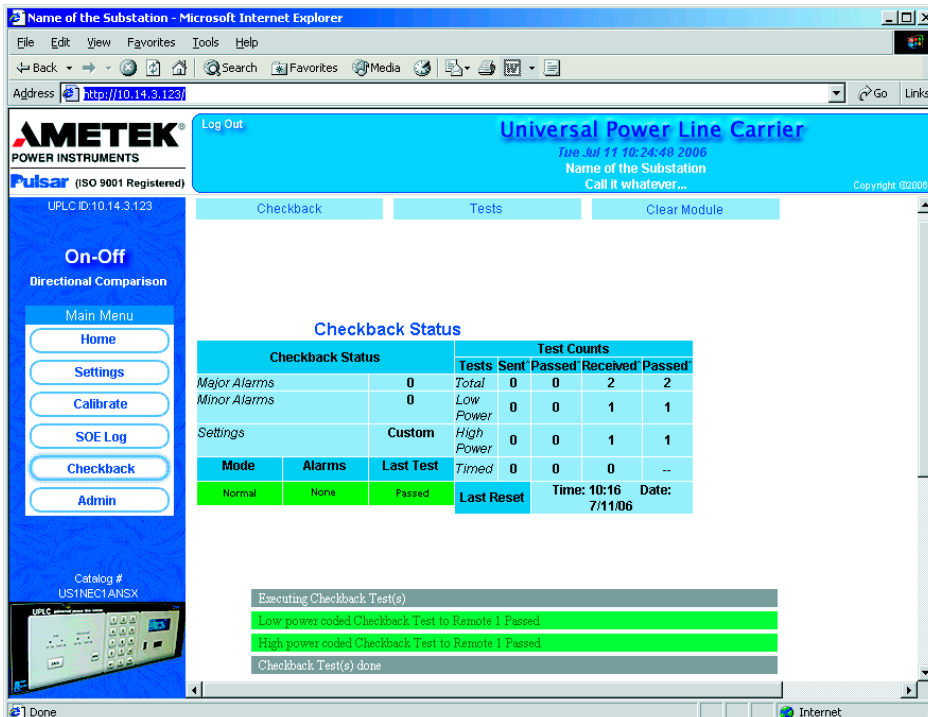

Figure 7-2. Checkback Test Results.

### 7.3.2 Checkback Outputs

**Delayed Alarm**—(Output set after a system fails to recover from auto recovery before the Carrier Recovery Window expires.)

**Test In Progress**—(Output set by the system initiating a checkback test for the duration of the test.)

**Successful Test**—(Output set after passing a checkback test.)

**Successful Carrier Recovery**—(Output set for one second after a successful recovery from automatic recovery mode.)

**Major Alarm**—(Output set when system fails a high-power test.)

**Minor Alarm**—(Output set when system fails a low-power test.)

**Disable Automatic Tests**—(Output set when the user has disabled automatic checkback tests.)

**In Auto Recovery Mode**—(Output set while in automatic recovery mode.)

You can program the alarm outputs to seal or just momentarily toggle when an alarm occurs. When you select sealed operation, the alarm outputs stay in their true, or energized, states as long as the alarm exists. If you select momentary, the outputs go to their true states for only five seconds, then return to their previous states. For example, assume alarms are set to momentary action and the major alarm active state is closed. Normally this output is open. When a major alarm occurs, the MAJOR ALARM output closes for five seconds then opens again. The MAJOR ALARM output does not change (again) when the major alarm is cleared.

## 7.4 Checkback Configuration

Each Automatic Checkback system in the carrier network has a unique address. By definition, remote #1's address is "1", remote #2's address is "2", and so on. The master is always assigned address "0". These addresses are used to define how a checkback unit behaves, as well as to allow distant communication between terminals. You

assign terminal addresses on the Checkback settings page.

### 7.4.1 Setting Descriptions

The checkback system can be configured in many ways. Following are descriptions of each setting.

### 7.4.2 Primary Comm Mode

This setting shows the communication mode that is initially used when the unit attempts a checkback test. There are two options: coded and timed. In coded mode, five-byte data messages are sent back and forth between units. In timed mode, the carrier is simply held on for several seconds; the actual time specifies with which unit we are trying to communicate: the master responds to a five-second carrier burst, remote #1 to 10 seconds, remote #2 to 15 seconds, and so on.

### 7.4.3 Fallback Timed Comm

When this setting is enabled and the Primary Comm Mode is set to "coded", the unit shifts communications mode to timed communication once it has failed all attempts to perform a coded checkback test. If the primary communications mode is already set to timed, the fallback feature is ignored.

### 7.4.4 Last Remote

Your network may contain more than two checkback terminals (i.e., one master and one remote). Among other things, this setting lets the unit know the final address to which it needs to send a checkback test request. If the primary communication mode is set to "timed", you can have up to four (4) remotes. If it is set to "coded", you can have up to 10 remotes. (see Figures 7-3 & 7-4)



### 7.4.5 Interval Type

The interval setting specifies how you want automatic checkback tests to be performed. You have two options: Timed and Periodic. In "timed" mode, automatic checkback tests are performed at your four user-specified times. These might be, say, 6:00, 12:00, 17:00, and 23:00. In "periodic" mode, automatic tests are performed every so many hours, for example, every eight (8) hours.

### 7.4.6 Carrier Recovery

You can set a unit to start "automatic carrier recovery" mode after failing a checkback test. In this mode, the unit initiates more frequent automatic checkback tests until it has three successful, consecutive tests. It then reverts to the normal checkback schedule, that is, "timed" or "periodic" checkback tests.

A remote also starts its version of automatic recovery after failing its own checkback attempts. Once in automatic recovery mode, a remote does not initiate any automatic checkback requests. It remains in automatic recovery mode until it passes three checkback tests. Normally, these tests are issued automatically by the master, but you can speed things up by executing manual tests at a remote or the master. After three good tests, remotes also resume normal operation.

When starting automatic recovery mode, a system slowly flashes the front panel with reco, to indicate it is in recovery.

### 7.4.7 Retries

During noisy line conditions, remote messages may contain errors that cannot be fixed at the destination module. With this setting, you can specify the maximum number of times you want the module to automatically resend a message. The valid range is zero (0) to 15 (times). A good compromise between communication speed and robustness is a setting of "3" to "5".

### 7.4.8 Auto tests

Automatic checkback tests can be enabled or disabled. Normally, you would probably want them to be enabled. But if, for example, you are installing a new checkback system, you might

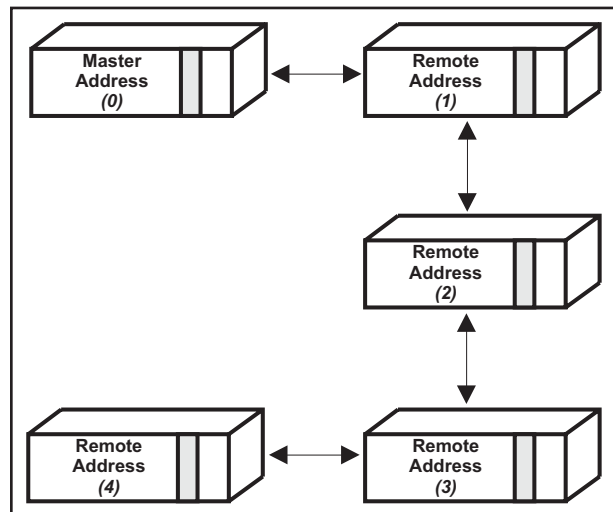

Figure 7-3. Maximum Checkback Configuration in Timed Communications Mode.

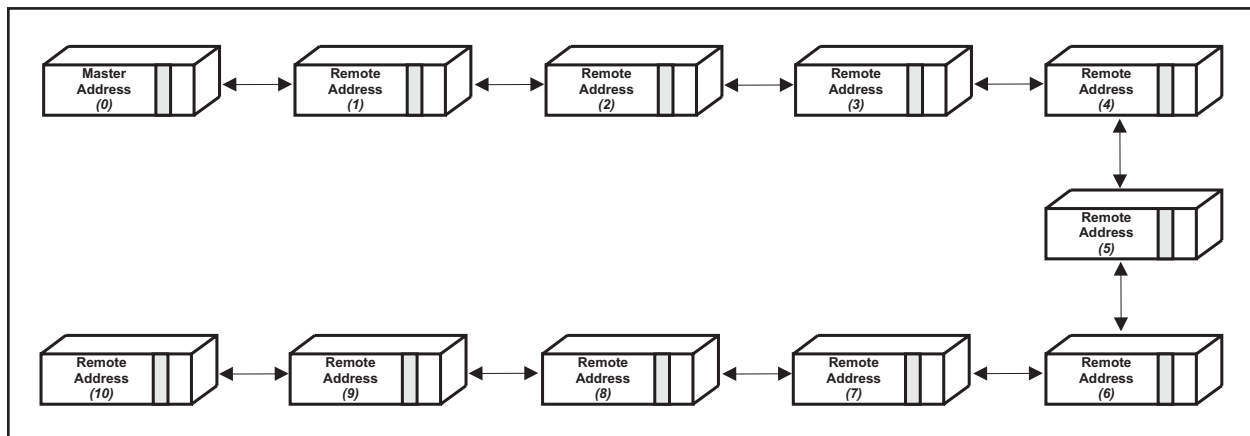

Figure 7-4. Maximum Checkback Configuration in Coded Communications Mode.

want to disable automatic checkback tests until all units are in place. When auto tests are disabled at a unit, it does not issue checkback tests unless manually commanded by you, the user. In addition, the master unit does not issue the automatic clock update at around 12:30 AM. In other words, no unit sends any command, unless you specifically command it.

### 7.4.9 Low Power Tests

Here, you can enable or disable the low power setting during checkback tests. When enabled, all checkback tests initiated by this unit are first performed on low power, then high power. When disabled, only the high-power test is performed.

### 7.4.10 Checkback Time 1-4

These settings let you set the four times at which you want to execute automatic checkback tests for timed checkback tests. When you set the Interval Type to "timed", the master initiates a checkback test at each of these times. You can set these times only to the nearest hour, using a 24-hour format. The master actually executes a timed test five minutes after the hour (e.g. 4:05). This delay provides some "wiggle" room to compensate for unsynchronized checkback clocks. Remotes that have their Interval Types set to Timed also use these times to initiate their own checkback tests, if they do not hear from the master within a grace period. The grace period is ten minutes after the hour for remote #1, fifteen minutes for remote #2, and so on.

If you do not want to use all four times, say you are only interested in three tests per day, you can simply set one of the times equal to another. For example, you could set time 1 to 12:00, time 2 to 6:00, time 3 to 18:00, and time 4 to 18:00 as well.

If the current Interval Type is Periodic, the word "Inactive" is displayed next to the checkback times. This means that these times are disabled and checkback tests occur according to the periodic interval (e.g., in the above example, every 8 hours). When you set the Interval Type to "timed", these times become active and the Periodic time is inactive.

### 7.4.11 Checkback Period

As mentioned earlier, the checkback period is enabled when the Interval Type is set to "periodic". If you wanted three tests per day and really did not care about the time of day when they occurred, you could set this time to, say, 8 hours. Masters attempt periodic checkback tests at exactly this time, in our case eight hours since the last test. Remotes have a grace period before they, too, attempt a checkback test, if they have not heard from the master. For example, remote #1 would do a checkback test after eight hours and five minutes, if it did not receive a checkback test from another unit.

### 7.4.12 Loopback Duration

The loopback duration specifies how long a module holds the carrier on during a loopback test. Loopback tests are performed at both high and low power. If you are at remote #1 and request a loopback test at the master, it turns the carrier on high power then on low power for the duration of the time. You can use loopback tests to set the sensitivity of your local receiver or other such tasks. The range of times is four to 60 seconds.

### 7.4.13 Carrier Recovery Period

When the master is in carrier recovery mode after failing a checkback test, it begins initiating checkback tests according to the carrier recovery period. For example, if the carrier recovery period is 15 minutes, the master tries another checkback test every 15 minutes. It remains in carrier recovery mode and continues to initiate tests every 15 minutes, until it has successfully completed three consecutive checkback tests. At that time, it shifts back to the normal mode, either periodic or timed checkback tests.

### 7.4.14 Carrier Recovery Window

The carrier recovery window is a time limit for the delayed alarm. If a unit goes into carrier recovery mode and does not recover before this time limit, it sets the delayed alarm. If any user-programmable output is set to delayed alarm, it becomes active. The main reason for having a carrier recovery window and delayed alarm is to cut down on

nuisance alarms. With this window and the delayed alarm, you can design a system that only alerts you when a true, long-term problem exists. The valid range for this window is 1 to 24 hours.

#### 7.4.15 Auto Clock Sync

When the auto clock sync is enabled, the master synchronizes all remote clocks to its own time, starting at 12:30 a.m. In practice, the synchronization is rough, within about +/- 2 seconds. But that is sufficiently accurate for Timed checkback testing.

#### 7.4.16 Clock

You set the clock's date & time via the front panel, using the 24-hour format, specifying all four digits for the year.

### 7.5 Performing Checkback Tests

The Automatic Checkback system's primary function is to perform checkback tests, verifying that your carrier communication path is operating. You can perform checkback tests in several ways:

- Manual request from the front panel tests
- Manual request from the web pages
- Automatic timed test
- Automatic periodic test
- Automatic carrier recovery
- Remote-initiated tests (via an input)

#### 7.5.1 Manual Request from Web Pages

By clicking on the left-hand navigator "Checkback", you can run manual tests, clear events, counts and alarms. Sample test results are shown in Figure 7-2.

#### 7.5.2 Automatic Timed Test

When this option is enabled, the master checkback initiates checkback tests at four user-specified times. For example, you might set these times to be 4:00, 13:00, 14:00, and 23:00. You can only set times to the nearest hour. The test then occurs at the start of the hour plus five minutes, unless the unit is busy with another message.

#### 7.5.3 Automatic Periodic Test

Instead of a timed test, you can set the master checkback to initiate tests periodically, say, every four hours. The shortest interval you can set is one hour, and the longest is 120 hours. The periodic interval is reset after one of the following:

- Sending or receiving a good checkback test, including manual tests
- Attempting to execute a checkback test at the Periodic Interval

#### 7.5.4 Automatic Carrier Recovery

You can set a unit to begin more frequent tests after failing any of the above checkback tests. With the carrier auto recovery mode enabled, the master, after failing a test, switches to carrier recovery mode. In carrier recovery mode, checkback tests are performed periodically, but much more frequently than otherwise, for example, every 20 minutes. You can set this time from five minutes to one hour. After three consecutive successful tests, the carrier recovery output is set, and the master reverts to the normal automatic tests.

You can accelerate recovery by performing manual tests at the master unit. After you execute three successful manual checkback tests, the master counts these as carrier recovery tests and reverts to normal mode. Note that while in recovery mode, the master only sends low-power checkback tests. This ensures that the line conditions are good before resuming normal operation.

After passing the three tests, any user defined outputs set to carrier recovery are set for five seconds.

#### 7.5.5 Remote-Initiated Periodic Tests

In some cases, a remote initiates its own checkback test. You can always manually request a test via the Web pages or Front Panel test menu. But the remote automatically does a checkback test if it detects the master is late. When a remote is set to do automatic periodic tests, it determines the master is late if it does not receive a checkback request within the user period plus some delay, or grace period. For remote #1, this grace period is five minutes.

For example, let's say your remote is set for automatic periodic testing, with a period of eight hours. If it does not receive a checkback test within eight hours and five minutes, it executes a checkback test. If this test is successful, both the master and the remote's periodic timers are restarted at roughly the same time, and the master takes over for subsequent checkback tests, if both units are set for the same periodic interval. The periodic timer starts as soon as the unit is powered, so that one will have a head start on the others. After the first successful checkback test, all the periodic timers in the network are synchronized, and the master initiates any future tests.

If you have more than one remote in your system, each has its own unique grace period. Remote #1 waits five (5) minutes, remote #2 waits 10 minutes, remote #3 waits 15 minutes, and so on.

For example, if neither remote #1 nor the master has initiated a checkback test for the interval plus 10 minutes, remote #2 executes a test.

For this scheme to work properly, it is important to keep all the settings similar. If the master is set for automatic periodic testing, all remotes should also be set this way. If not, you may have more checkback tests occurring than you would expect at equally unexpected times. Also, the four execution times should be the same for all units in the system.

### 7.5.6 Remote-Initiated Timed Tests

Just as with remote-initiated periodic testing, remotes set to timed testing initiate their own checkback tests if the master does not do a test in time. The "grace" period is longer for this mode:

user time + 10 minutes for remote #1, user time + 15 minutes for remote #2, etc. That allows this scheme to work even when there is up to five minutes difference between the checkback units' clocks.

For automatic timed testing, the clocks in the master and the remotes should be fairly close.

You can enable the automatic clock synchronization feature to keep your clocks synchronized. When enabled, the master synchronizes all remote clocks to its own time starting at 12:30 a.m. In practice, the synchronization is rough, within about +/- 2 seconds, but that is sufficiently accurate for timed checkback testing.

## 7.6 Checkback Test Options

A single checkback test is a set of encoded data messages, a simple keyed carrier signal, or a mixture of both. You have several options for performing this test:

- Keyed carrier timed test
- Encoded carrier test
- Primary and fallback communication modes
- Communication retries

### 7.6.1 Keyed Carrier Timed Tests

This is the classic method where the checkback simply turns on the carrier for a specific interval of time. Each unit in the system is assigned a unique time and can recognize when the carrier has been on for the correct interval. The correct unit

Table 7-1. Primary/Fallback Communications Options.

Primary Mode	Fallback Timed	Description
Coded	Disabled	No more tries after max retry count
Coded	Enabled	Makes one last try using Timed Mode
Timed	Disabled	No more tries after max retry count
Timed	Enabled	No more tries after max retry count

responds by keying the carrier for a predetermined interval.

The unit identifying times are:

- Master recognizes a five-second carrier
- Remote #1- recognizes a 10-second carrier
- Remote #2- recognizes a 15-second carrier
- Remote #3- recognizes a 20-second carrier
- Remote #4- recognizes a 25-second carrier

### 7.6.2 Encoded Carrier Tests

Encoded tests involve sending serial data messages back and forth between checkback units. This method has two advantages over the keyed carrier method: (1) it is usually faster and (2) you can communicate with more units. The disadvantage with this method is that it is more vulnerable to noisy line conditions that may result in a failure to send a good message. To prevent errors in the received data, the unit sends a 16-bit CRC code with each message. This error detecting code enables the unit to detect bad messages and, in some cases, repair them.

### 7.6.3 Primary & Fallback Communications Modes

A UPLC™ first uses the primary communications mode when performing a checkback test. It makes several attempts to communicate, up to the number in the "Retries" setting. If all attempts fail, it switches to the timed communication mode, if "Fallback Timed Comm" is enabled and the "Primary Comm Mode" is coded.

Once in timed communication mode, the unit makes one final attempt to get through. If that fails, it sets a major alarm. If it passes, no alarm is issued.

### 7.6.4 Communication Retries

To increase the communication robustness, the checkback system can make repeated attempts to get a message or signal through to another unit. When the channel is noisy or weak, multiple attempts are often successful. Setting a high retry number, say 15, increases the likelihood of success (slightly), but can cost a lot of time waiting for a failure. We think that three (3) to five (5) is a good compromise between speed and robustness.

## 7.7 Troubleshooting

You can identify and solve many checkback network problems by examining the major and minor alarms. If both high and low power checkback tests are enabled, the major and minor alarms work like this:

- If a unit fails only the low power test, it sets the minor alarm
- If a unit fails the high power test, it sets the major alarm
- If a unit fails the high power test and can not receive its own messages, it sets both major and minor alarms

Armed with this information, you can usually identify a failed unit or line problem. the Network Troubleshooting table lists all combinations for a two-unit system and the probable situation.

To get the complete picture, you must wait long enough for all remotes to initiate their own checkback tests. For example, if the master has a major alarm, but the remote has no alarms, you can not determine if it failed to receive the command due to a bad line or because its receiver failed. By waiting for the remote to initiate a checkback, you can tell if it is the line (major alarm) or the unit (both alarms).

Table 7–2. Network Troubleshooting.

<b>ALARMS</b>				
<b>Master Module</b>		<b>Remote Module</b>		<b>Probable Situation</b>
<b>Major</b>	<b>Minor</b>	<b>Major</b>	<b>Minor</b>	
clear	clear	clear	clear	All OK
clear	clear	clear	set	Weak/noisy line
clear	clear	set	clear	Master or line failed
clear	clear	set	set	Remote failed
clear	set	clear	clear	Weak/noisy line
clear	set	clear	set	Weak/noisy line
clear	set	set	clear	Weak/noisy line or master failed
clear	set	set	set	Remote failed
set	clear	clear	clear	Remote or line failed
set	clear	clear	set	Remote or line failed
set	clear	set	clear	Line failed
set	clear	set	set	Remote failed
set	set	clear	clear	Master failed
set	set	clear	set	Master failed
set	set	set	clear	Master failed
set	set	set	set	Master and remote failed

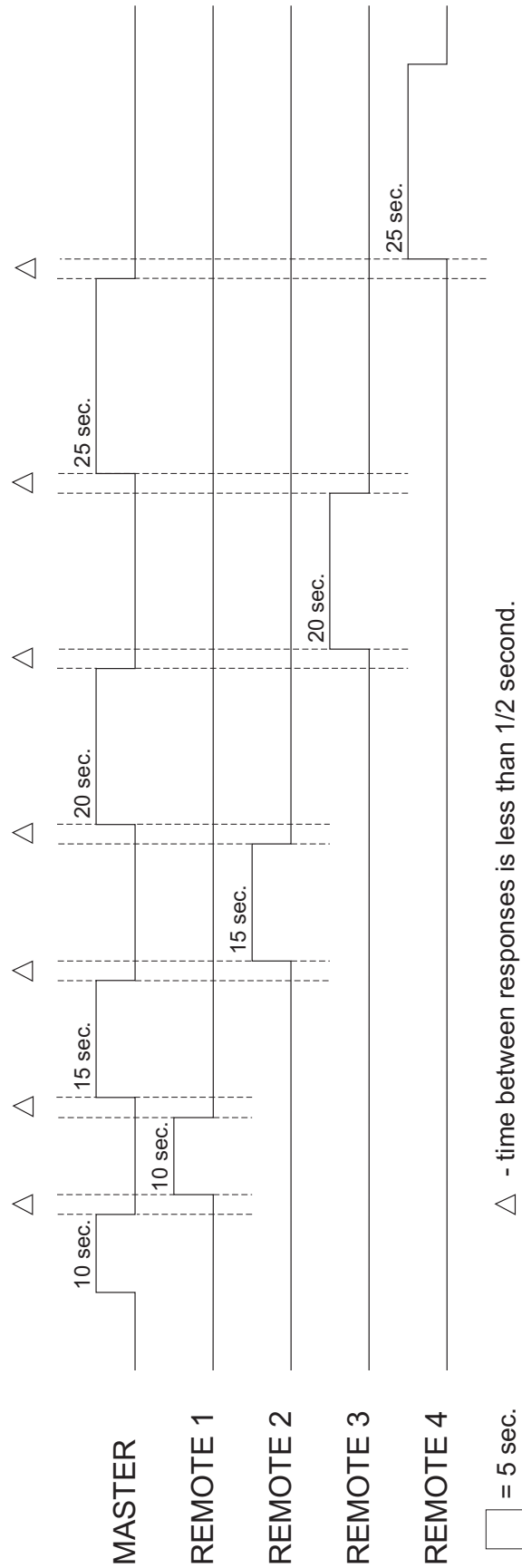
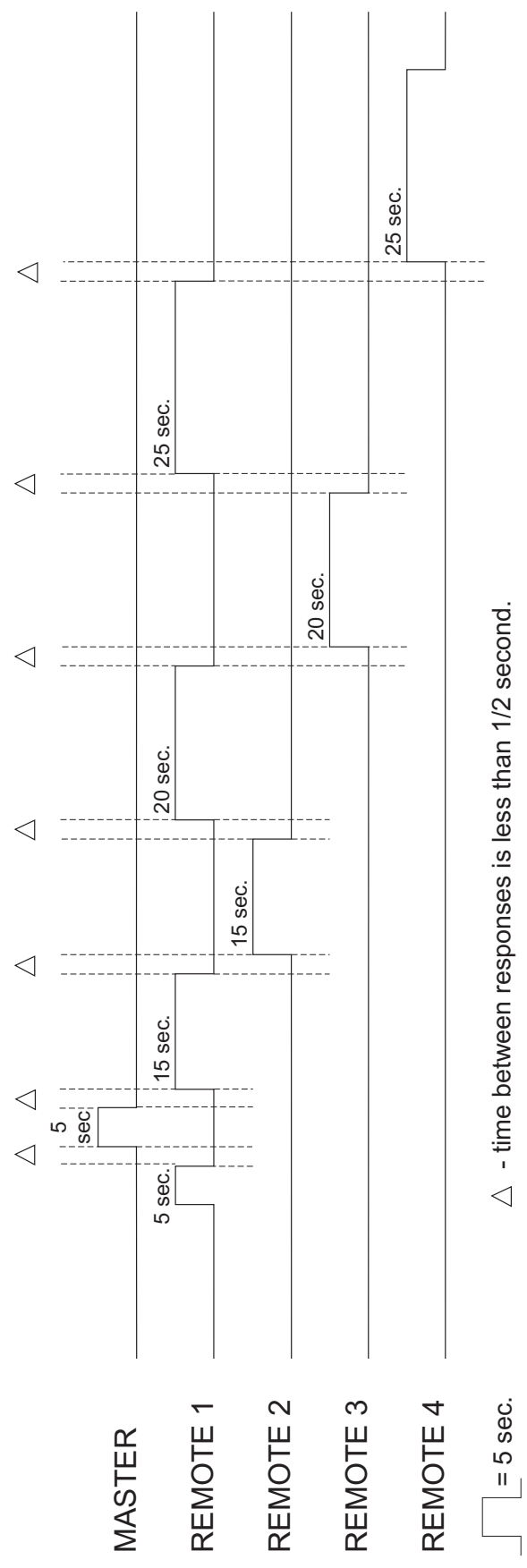

Figure 7-5. Timed Checkback Sequence (Master Initiation).

Figure 7-6. Timed Checkback Sequence (Remote 1 Initiation).





## FSK Trip Test Facilities

### 7.8 General Description

The optional Trip Test is designed to test FSK two-frequency or three-frequency transfer trip units using the UPLC™ or TCF-10B. Two transmitters with trip test, one at each end of the line, are needed to perform this testing function.

Trip testing is not functional on 3-terminal lines.

The Web pages and Timing Diagrams for the trip test are shown at the end of this chapter.

The Trip Test can be used to functionally test the transmitters and receivers at both ends of a two terminal line with having only a person at one end. Please note it is not applicable to three terminal lines.

The Trip Test on the UPLC™ works in conjunction with the local receiver as well as the remote receiver and transmitter to test the ability of the system to shift to the trip frequency and receive the trip frequency at the opposite end.

For 2-frequency FSK systems, the trip test can be set for a “real” trip or a “checkback” trip. The “real” trip will produce an output of the receiver logic TRIP. A “Checkback” Trip setting will provide only a checkback trip output from the receiver logic, which can be used to pick up an auxiliary relay or indicating light. Only the “checkback” trip setting can be used for 3-frequency systems.

#### 7.8.1 Two Frequency Applications Real Trip Scenario

In this application, the local end, at which you initiate a Trip Test, will receive a real TRIP as well as a CHECKBACK TRIP, but the remote end will only produce a CHECKBACK TRIP. When using this application the end that initiates the trip would have to be disconnected from the trip relays.

Refer to the timing diagrams at the end of this chapter.

When a trip test is initiated, the local transmitter shuts down for 2 seconds. The remote end receiver will see this as a loss of channel. After 2 seconds, the local transmitter then keys to the trip fre-



### CAUTION

- IF THE UNIT IS SET FOR A REAL TRIP, THEN CAUTION SHOULD BE TAKEN TO OPEN THE TRIP CIRCUIT PATH SO AS NOT TO MISTAKENLY TRIP OUT A BREAKER OR LOCKOUT RELAY ON A DIRECT TRANSFER TRIP SYSTEM.
- THE RECEIVER LOGIC MUST BE SET FOR “GUARD BEFORE TRIP” LOGIC.

quency for 2 seconds. The remote end recognizes this as a Trip Test command and the remote receiver will then produce a CHECKBACK TRIP and key the remote transmitter to the trip frequency for 2 seconds. The local end receiver sees that as a REAL TRIP and produces a TRIP and CHECKBACK TRIP output from the logic card and the electromechanical card.

#### 7.8.2 Two Frequency Application Checkback Trip Scenario

In this application, both the local and remote ends shift to “checkback” trip. No trip outputs have to be disconnected.

Refer to the timing diagrams at the end of this chapter.

When a trip test is initiated, the local transmitter shuts down for 1.5 seconds. The remote end receiver will see this as a loss of channel. After 1.5 seconds, the local transmitter then keys to the trip frequency for 0.5 second. The remote end recognizes this as a Trip Test command and the remote receiver will then produce a CHECKBACK TRIP and shut down the remote transmitter for 2 seconds. The remote transmitter is then keyed to the trip frequency for 0.5 second. This in turn produces a loss of channel and CHECKBACK TRIP (without a real TRIP) at the local end.

#### 7.8.3 Three Frequency Applications Checkback Trip Scenario

In this application, both the local and remote ends shift to “checkback” trip. No trip outputs have to be disconnected. Both trips (DTT & unblock/POTT) are checked. DTT is low frequency and unblock/POTT trip is high frequency.

Refer to the timing diagrams at the end of this chapter.

When a trip test is initiated, the local transmitter shuts down for 1.5 seconds. The remote end receiver will see this as a loss of channel. After 1.5 seconds, the local transmitter then keys to the lower trip frequency for 0.5 second. The remote end recognizes this as a Trip test command and the remote receiver will then produce a CHECKBACK TRIP1 and shuts down the remote transmitter for 2 seconds. The remote transmitter is then keyed to the lower trip frequency for 0.5 second. This in turn produces a loss of channel and DTT CHECKBACK TRIP (without a TRIP) at the local end's receiver. Then the system needs to check for the UB TRIP function. In a similar way, the local end will send a UB CHECKBACK TRIP to the remote and the remote receives and then returns a UB CHECKBACK TRIP to the local receiver.

#### **7.8.4 Trip Test Initiation**

You initiate a trip test sequence by front panel testing, web page request or asserting the trip test initiate input (if programmed).

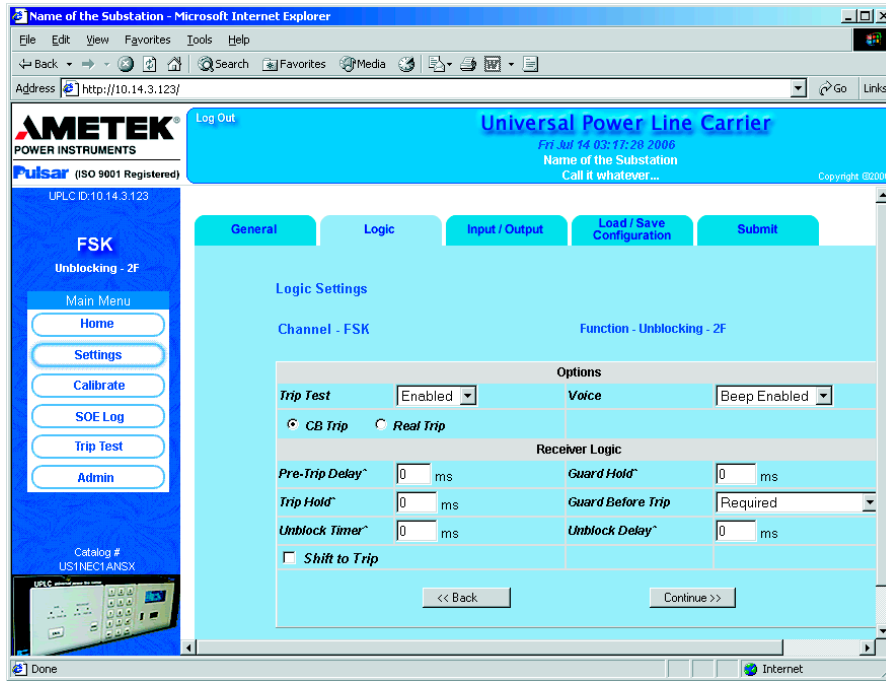

7

Figure 7–7. Example of The Trip Test Logic Page for 2-Frequency FSK.

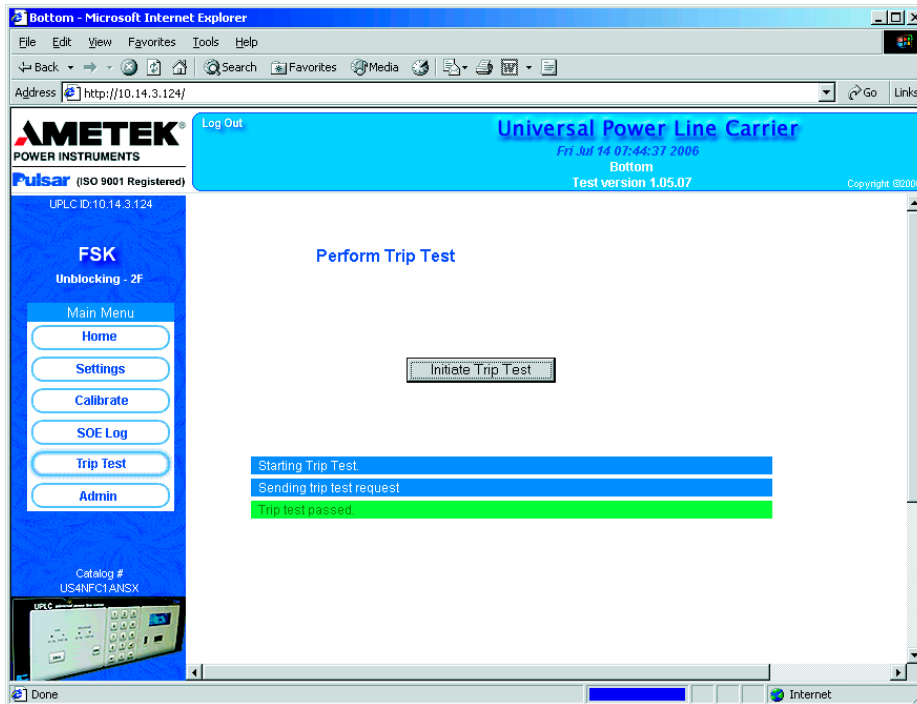

Figure 7–8. Example Page After a Successful Trip Test.

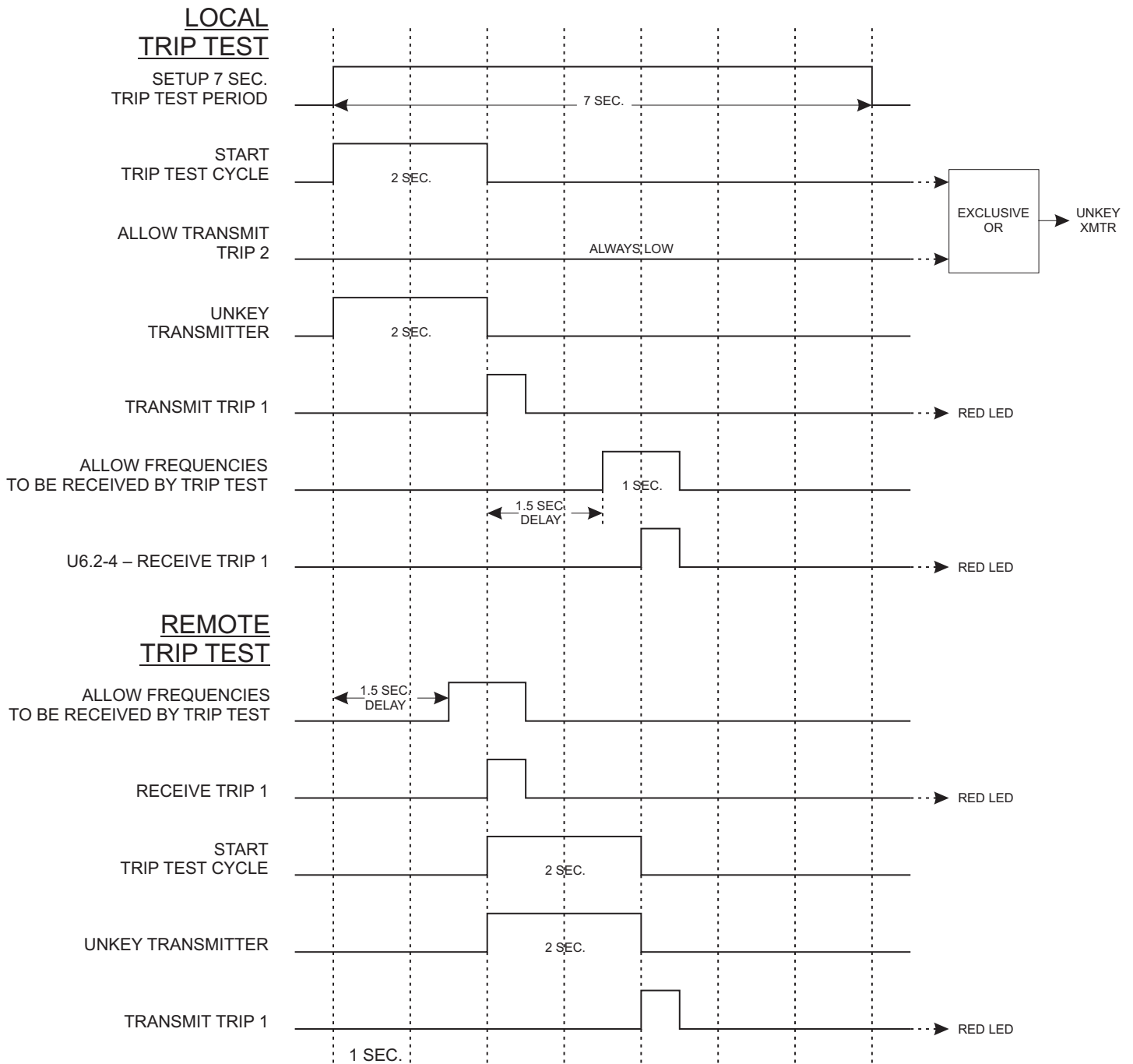

Figure 7-9. Trip Test 2-Frequency Checkback Trip Timing Diagram.

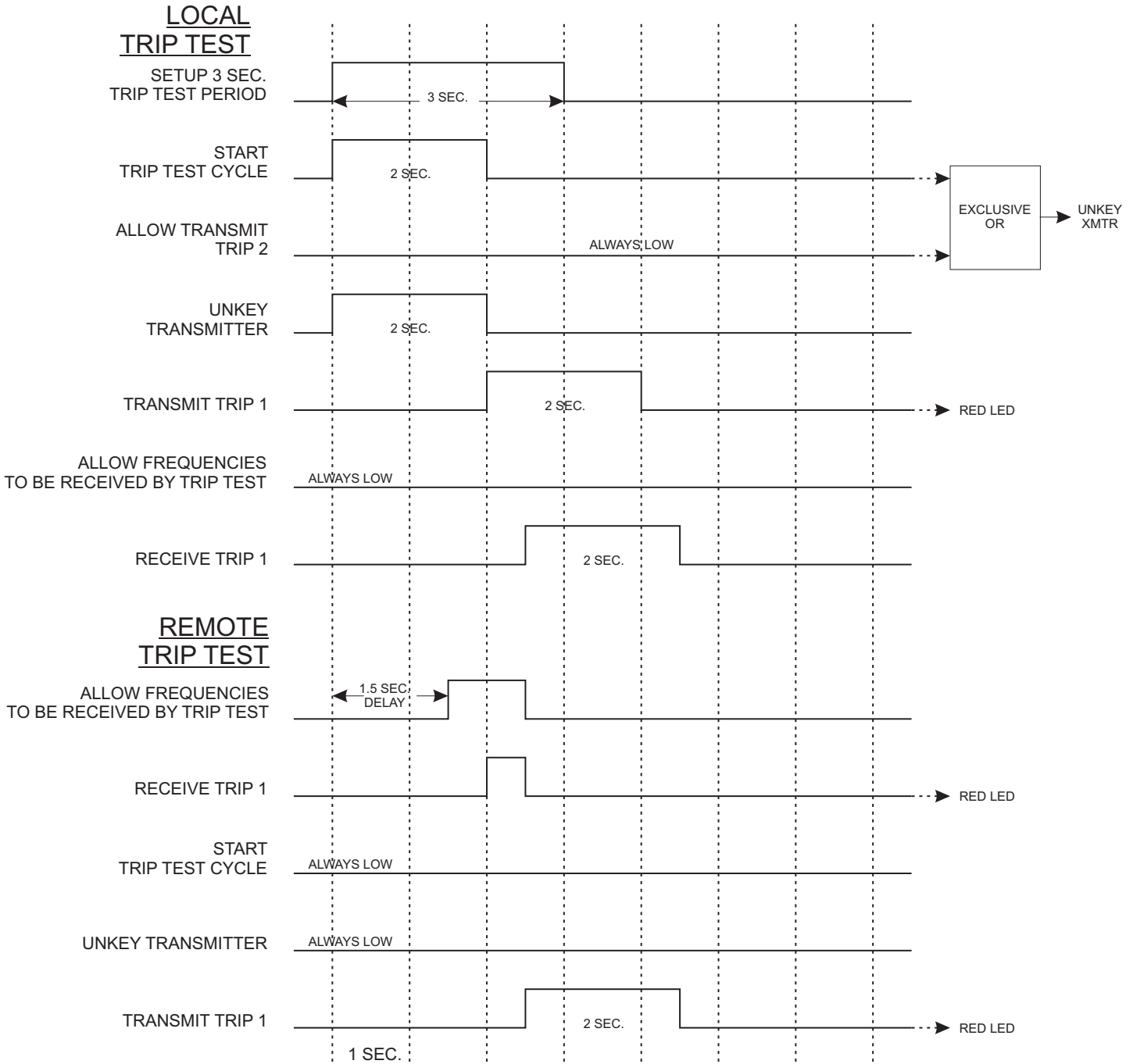

Figure 7-10. Trip Test 2-Frequency Real Trip Timing Diagram.

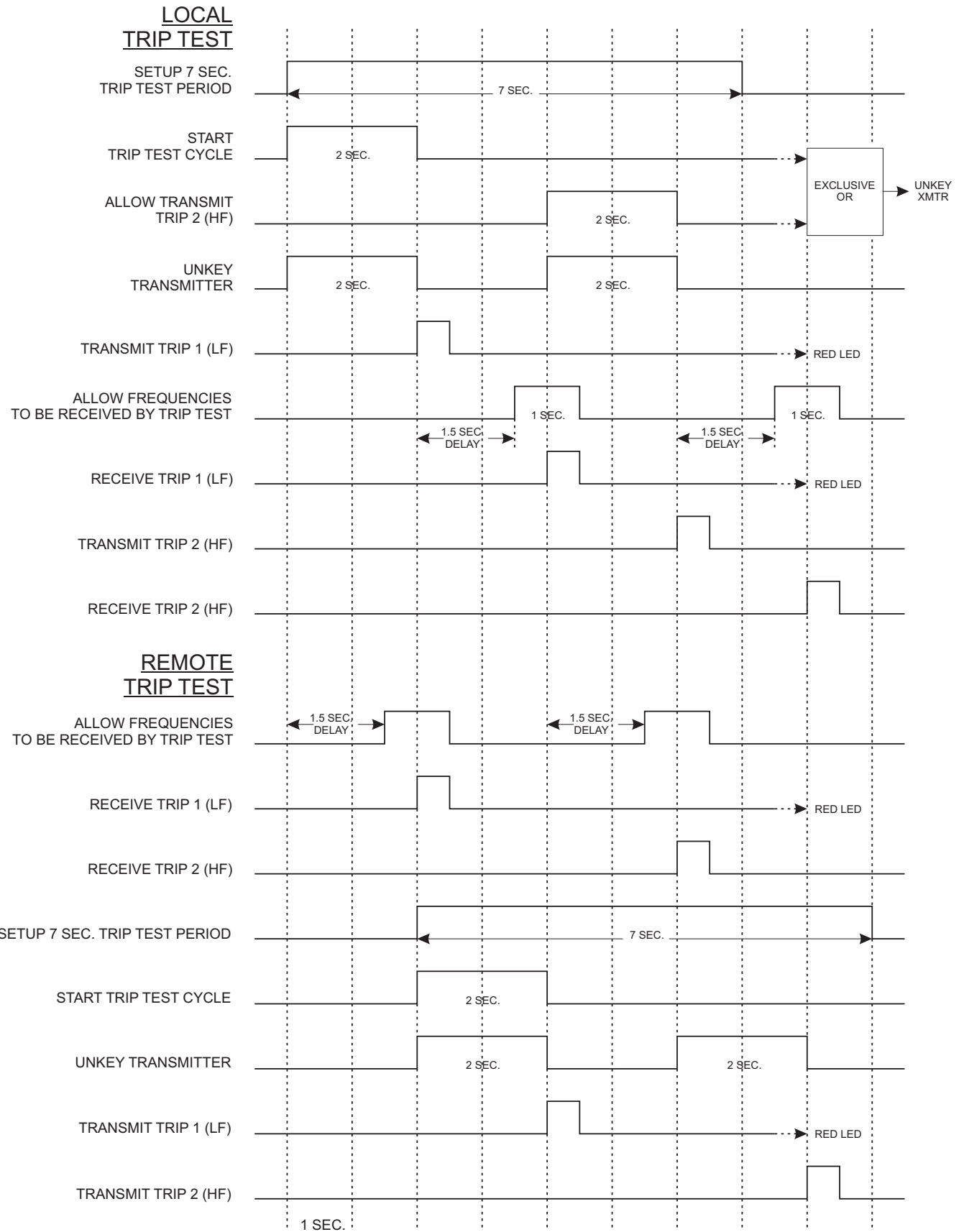

Figure 7–11. Trip Test 3-Frequency Checkback Trip Timing Diagram.

# Chapter 8. Protocols

The UPLC™ is available with separate protocols. The Distributed Network Protocol, DNP 3; and the IEC61850 object oriented standard.

## 8.1 DNP 3

The UPLC™ can communicate via DNP 3 using one of the following ports/standards.

- Std. rear 9-pin D-sub connector (J4) via RS-232\* (Use Std. Straight-through 9-pin Serial Cable, Male to Female)
- Standard rear 9-pin D-sub connector (J4) via RS-485 (TX- = pin#2, TX+ = pin#8, RX- = pin#3, RX+ = pin#7)
- Optional rear Ethernet connector (TX1/RX1 or TX2/RX2) via TCP/IP-UDP

The account holder must have “User” privileges to set the DNP communications.

The UPLC™ DNP communications works in a slave mode as an outstation device and supports level 1 & 2 of the DNP 3 protocol. A DNP device profile can be generated by downloading the UplcDnpCfg.xml file into a folder with the appropriate DNP device profile xsd, xsx & xslt files (2009) and then opening the UplcDnpCfg.xml file.

### 8.1.1 DNP 3 Settings

#### 8.1.1.1 Main DNP Web Page Settings

The following settings must be made on the main DNP page.

- 1) Click on the Admin button in the left task bar.
- 2) Next, click on the Protocol tab.

\* Terminal Emulator Program Settings:  
Data Bits/Per Word = 8  
Stop Bits = 1  
Parity = None  
Flow Control/Handshake = None

- 3) Finally, click on the DNP tab.

If the physical layer is set to RS-232 or RS-485 mode, a Baud rate must be chosen. For the TCP/IP-UDP mode, an IP port must be chosen.

- Physical Layer = RS-232 or RS-485
- Baud = 2400, 4800, 9600, 19200, 38400 or 115200
- Physical layer = TCP/IP-UDP
- IP Port = 20000 (default) or 49152-65535
- UPLC™ DNP address = 1-65519
- Link Layer Confirm = Never, Multi or Always
- Unsolicited Responses = Disabled or Enabled

If “Unsolicited Responses” is enabled, the following additional settings must be made.

- Master DNP Address = 1-65519
- Confirmation Timeout (secs) = 1-60
- Number of Retries = 1-5 or indefinite

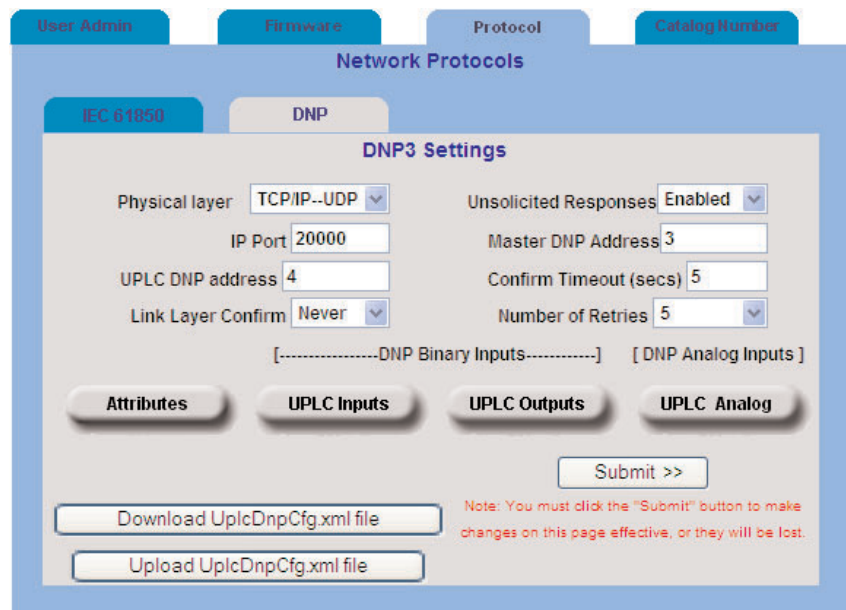

Figure 8-1 DNP Page  
(Admin > Protocol > DNP)

### 8.1.1.2 Secondary DNP Web Page Settings (Setting Up Data Points)

The UPLC™ sends only Binary Inputs and Analog Inputs to an RTU or SCADA master station. There are no DNP Outputs accepted by the UPLC™ from an RTU or SCADA master station. All points are programmable as to whether they will be included in a particular class poll and also to what variation (type of value) will be returned in the poll. All points can be set to a Class of “off” if the point is not valid for the selected UPLC™ function. All binary points in the UPLC™ report a value of 0 when “off” and a value of 1 when “on”.

A separate pop-up window/page appears when you click on each of the 4 buttons at the bottom of the main DNP page. Only one pop-up page can be displayed at a time. Pop-up pages should be closed after viewing or changing. To close the page, you must either click “Submit”, to send the changes to the UPLC™, or click the “X” in the upper right corner of the page if there are no changes.

Basic information regarding the UPLC™ is located on the Attributes page. The following attributes, in green cells, can be edited.

- User-Assigned Location Name
- User-Assigned ID Code Number
- User-Assigned Name for Outstation

For the 3 DNP Input Web pages,

- 1) “UPLC Inputs” (Binary)
- 2) “UPLC Outputs” (Binary)
- 3) “UPLC Analog” (Analog)

the following settings must be made in the pop-up Web pages.

- Event/Static Data Class = Off, 0–3
- Description = Long Character String that User Can Enter Describing the DNP Input
- Default Variation for Static Data = 1–3 (1-5 for Analog Inputs only)
- Default Variation for Event Data = 1–3 (1-5 for Analog Inputs only)

Please refer to the following figures.

**NOTE**  
You Can Double Click in Green Cells to Edit.

Variation	Dnp Type	Value
242	Device manufacturer’s software version string	3.06.09
243	Device manufacturer’s hardware version string	Rev 9
245	User-assigned location name or code string	Substation XX
246	User-assigned ID code/number string	Panel XX
247	User-assigned name string for the outstation	UPLC XX
248	Device serial number string	00075E000F17
249	DNP subset level and conformance	DNP3 Level 2
250	Device manufacturer’s product name and model	UPLC Model US1NSC5ANSX
252	Device manufacturer’s name string	Ametek Power Instruments, Inc.

Figure 8–2 UPLC DNP Attributes Page (Admin > Protocol > DNP > Attributes)



## 8.2 DNP Binary Inputs (UPLC Inputs)

The UPLC™ has five physical binary inputs that can be assigned numerous functions chosen from a selection menu. The following tables include all possible input selections for the UPLC™ ON-OFF and FSK modes. Since there are only five inputs

and many possible selections, at any given time some of these selections will be unassigned or not used. The on-line bits of these unassigned selections will be set to zero.

Point Index	Name	Event/Static Data Class	UPLC function for which point is valid	Description	Default Variation for Static Data	Default Variation for Event Data
0	Carrier Start Key	1	All On-Off Modes	Example: Carrier started by Relay XX	1	1
1	Carrier Stop Key	1	All On-Off Modes		1	1
2	Low Level Key	2	All On-Off Modes		1	1
3	CB Alarm Reset	Off	Checkback option only		2	2
4	CB Test Initiate	Off	Checkback option only		3	3
5	Loop Test Initiate	Off	Checkback option only		1	1
6	User SOE 1 Key	3	All On-Off Modes		1	1
7	User SOE 2 Key	3	All On-Off Modes		1	1
8	User SOE 3 Key	3	All On-Off Modes		1	1
9	High Power Key	1	All On-Off Modes		1	1
10	Low Power Key	1	All On-Off Modes		1	1

Figure 8–3 DNP Binary Inputs / UPLC Inputs Settings Page  
(Admin > Protocol > DNP > UPLC Inputs)

Table 8–1 UPLC Inputs – DNP Points for ON-OFF Mode

Point	Name	Setting Mode	Definition
0	Carrier Start Key	All ON-OFF Modes	Carrier Start Input has been Keyed
1	Carrier Stop Key	All ON-OFF Modes	Carrier Stop Input has been Keyed
2	Low Level Key	All ON-OFF Modes	Low Level Keying Input has been Keyed
3	CB Alarm Reset	Checkback Option Only	Checkback Alarms have been Reset
4	CB Test Initiate	Checkback Option Only	Checkback Test has been Initiated
5	Loop Test Initiate	Checkback Option Only	Loop Back Test has been Initiated
6	User SOE 1 Key	All ON-OFF Modes	SOE Event 1 Input has been Keyed
7	User SOE 2 Key	All ON-OFF Modes	SOE Event 2 Input has been Keyed
8	User SOE 3 Key	All ON-OFF Modes	SOE Event 3 Input has been Keyed
9	High Power Key	All ON-OFF Modes	High Power Level has been Keyed
10	Low Power Key	All ON-OFF Modes	Low Power Level has been Keyed

Table 8–2 UPLC Inputs – DNP Points for FSK Mode

Point	Name	Setting Mode	Definition
0	3F DTT Trip Key	3-Freq. Only	DTT Trip Input Keyed (for 3–Freq. Mode)
1	LR Trip Key	2 or 3-Freq.	Line Relaying Trip Input Keyed (Unblock/2F, UB/POTT/3F)
2	TX Power Off Key	All FSK Modes	TX RF Power Off Input Keyed (Turns TX Off for Test)
3	TX Pwr Boost Key	All FSK Modes	Power Boost Input has been Keyed
4	User SOE 1 Key	All FSK Modes	SOE Event 1 Input has been Keyed
5	User SOE 2 Key	All FSK Modes	SOE Event 2 Input has been Keyed
6	User SOE 3 Key	All FSK Modes	SOE Event 3 Input has been Keyed
7	PC Key	Phase Comp.	Phase Comparison Input has been Keyed
8	Trip A Key	4-Freq. Only	Trip Channel A Input has been Keyed
9	Trip B Key	4-Freq. Only	Trip Channel B Input has been Keyed
10	Initiate Trip Test	Testing Only Option Enabled	Trip Test Input has been Keyed (for Testing Purposes Only)
11	2F DTT/POTT Trip Key	2-Freq. Only	DTT Trip of POTT Trip Input has been Keyed
12	TX Keyed Off	All FSK Modes	Transmit Keyed Off

### 8.3 DNP Binary Inputs (UPLC Outputs)

The UPLC™ has 10 or 14 binary outputs, depending on the model. Like UPLC™ inputs, you can assign these outputs in numerous ways. The following tables include all possible output selections for the UPLC™ ON-OFF and FSK modes. Since there are more selections than outputs, at any given time some of these selections will be unassigned and their on-line bits will be set to zero.

Point Index	Name	Event/Static Data Class	UPLC function for which point is valid	Description	Default Variation for Static Data	Default Variation for Event Data
11	General Failure	1	All On-Off Modes	Example: UPLC XX in Panel XX has failed.	1	1
12	RX Signal Off	Off	All On-Off Modes		2	2
13	TX Refl Pwr Alarm	2	All On-Off Modes		3	3
14	RX Block Out	2	All On-Off Modes		1	1
15	RX Carrier Out	2	All On-Off Modes		1	1
16	TX Main RF On	2	All On-Off Modes		1	1
17	TX Redundant RF On	2	All On-Off Modes - If Present		1	1
18	Main PA Alarm	2	All On-Off Modes		1	1
19	Redundant PA Alarm	2	All On-Off Modes - If Present		1	1
20	Main PS Alarm	2	All On-Off Modes		1	1

Figure 8–4 DNP Binary Inputs / UPLC Outputs Settings Page  
(Admin > Protocol > DNP > UPLC Outputs)

Table 8–3 UPLC Outputs – DNP Points for FSK Mode

Point	Name	Setting Mode	Definition
13	General Failure	All FSK	Hardware Failure in the UPLC
14	RX Fade Alarm	All FSK	Rec. Level has Dropped Below Fade Alarm Setting
15	RX Noise Alarm	All FSK	Noise Alarm has Occurred
16	RX Good Chanel	All FSK	Channel Good (Rec. Signal Level & Freq. OK)
17	TX Refl Pwr Alarm	All FSK	% Refl Power Exceeded Alarm Threshold Setting
18	TX Main RF On	All FSK	TX Level on Main Power Amp Above 0.5W
19	TX Red. RF On	All FSK	TX Level on Redundant Power Amp Above 0.5W
20	Main PA Alarm	All FSK	Main Power Amp has Failed
21	Red. PA Alarm	All FSK	Redundant Power Amp has Failed
22	Main PS Alarm	All FSK	Main Power Supply has Failed
23	Red. PS Alarm	All FSK	Redundant Power Supply has Failed
24	Trip 1 Out	Non-PC FSK	Trip 1 Output Present (LF Trip for 2F, Line Relay Trip for 3F, Trip A for 4F)
25	Trip 2 Out	3F/4F Only	Trip 2 Output Present (DTT Trip for 3F, Trip B for 4F)
26	Guard 1 Out	Non-PC FSK	Guard 1 Output Present (HF Guard for 2F LR Guard for 3F, Guard A for 4F)
27	Guard 2 Out	3F/4F Only	Guard 2 Output Pres. (DTT Guard/3F, Guard B/4F)
28	CB Trip 1 Out	Non-PC FSK	Checkback Trip 1 Output Present (Rec. Trip 1 Freq.)
29	CB Trip 2 Out	3F/4F Only	Checkback Trip 2 Output Present (Rec. Trip 2 Freq.)
30	Trip Pos. Out	Phase Comp.	Trip Positive Output Present
31	Trip Neg. Out	Phase Comp.	Trip Negative Output Present
32	TX Shift High Freq	All FSK	Transmit Freq. Commanded to Shift High in Freq.
33	TX Shift Low Freq	All FSK	Transmit Freq. Commanded to Shift Low in Freq.
34	TX Shift Ch A Trip	4 Freq. Only	TX Freq. Keyed to Chan A Trip Freq. (F4)
35	TX Shift Ch B Trip	4 Freq. Only	TX Freq. Keyed to Chan B Trip Freq. (F2)
36	TX Shift ChAB Trip	4 Freq. Only	TX Freq. Keyed to Chan A/B Trip Freq. (F1)

Table 8–4 DNP Binary Outputs – UPLC Outputs for ON-OFF Mode

Point	Name	Setting Mode	Definition
11	General Failure	All ON-OFF	A Hardware Failure in the UPLC
12	RX Signal Off	All ON-OFF	Received Level Dropped Below Fade Alarm Setting (Active Unless Block Signal Received)
13	TX Refl Pwr Alarm	All ON-OFF	% Reflected Power has Exceeded Alarm Threshold Setting
14	RX Block Out	All ON-OFF	Carrier Block Output has Occurred from the UPLC
15	RX Carrier Out	All ON-OFF	Carrier Receive Output has Occurred from the UPLC
16	TX Main RF On	All ON-OFF	TX Level on Main Power Amp Above 0.5W
17	TX Redundant RF On	All ON-OFF If Present	TX Level on Redundant Power Amp Above 0.5W
18	Main PA Alarm	All ON-OFF	Main Power Amp has Failed
19	Redundant PA Alarm	All ON-OFF If Present	Redundant Power Amp has Failed
20	Main PS Alarm	All ON-OFF	Main Power Supply has Failed
21	Redundant PS Alarm	All ON-OFF If Present	Redundant Power Supply has Failed
22	CB Major Alarm	If CB Option Present	Checkback Major Alarm Occurred due to Failure of High Level Checkback Test
23	CB Minor Alarm	If CB Option Present	Checkback Minor Alarm Occurred due to Failure of Low Level Checkback Test
24	CB Delayed Alarm	If CB Option Present	Checkback Delayed Alarm Occured due to Failure to Exit Recovery Mode
25	CB Test Passed	If CB Option Present	Successful Checkback Test
26	CB Test in Progress	If CB Option Present	Checkback Test in Progress
27	CB in Recovery	If CB Option Present	UPLC Failed Checkback Test and is In Recovery Mode
28	CB Recovered	If CB Option Present	UPLC Successfully Recovered from a Checkback Test Failure, No Delayed Alarm
29	Auto CB Tests Off	If CB Option Present	Automatic Checkback Tests Have Been Turned Off

## 8.4 DNP Analog Inputs (UPLC Analog Values)

The UPLC™ has 4 analog UPLC measured values that can be set to be read via DNP.

Point Index	Name	Event/Static Data Class	UPLC function for which point is valid	Description	Default Variation for Static Data	Default Variation for Event Data
0	TX Signal Level	2	All	Example: UPLC XX's transmit level	2	2
1	RX Signal Level	0	All		5	1
2	RX Fade Margin	Off	All		2	2
3	Percent Reflected Power	3	All		2	5

Figure 8–5 DNP Analog Inputs / UPLC Analog Values Settings Page  
(Admin > Protocol > DNP > UPLC Analog)

Table 8–5 UPLC Analog Values (All Modes)

Point	Name	Definition
0	TX Signal Level	Measured Transmit Signal Level to Coax
1	RX Signal Level	Measured Receive Signal Level from Coax
2	RX Fade Margin	Measured dB RX Margin – Amount Signal can Fade & Still Work
3	Percent Reflected Power	Measured % Reflected Power for TX

## 8.5 IEC 61850 Protocol

### 8.5.1 UPLC™ with IEC 61850

IEC 61850 is the industry's standard for peer to peer communications within a substation. Data is transmitted over an Ethernet network in the substation, eliminating much of the wiring between devices that has historically been used to interconnect them. The UPLC™ is used as a pilot channel with transmission line relaying and major equipment breaker protection. Since IEC 61850 protocol allows for interconnecting the devices within the substation without the usual wiring, this eliminates the labor and cost associated with physical wiring. Since a template may be created for all the different devices, and copied for each project, this also eliminates the human factor in wiring errors from panel to panel.

It is not a point-to-point system but a multicast system whereby a message is generated by the UPLC™ to which the other devices in the substation subscribe. A new message is sent when there is a change to one of the data items and is repetitiously sent at increasing intervals until another data change occurs. Likewise, the devices and elements the UPLC™ has been programmed to subscribe to will produce these messages and the UPLC™ will respond accordingly. These messages can be a variety of functions, such as:

- Permission to trip or a block input for pilot relaying
- Request to initiate a checkback test function
- Alarm output
- Measured value such as transmitted power out or received level.

Some specifics to be aware of:

1. The LNodeType id is "ZPLC" and the InClass is "ZPLC".
2. The user will need to assign:
  - UPLC™ IEC name (the generic name the subscribing unit may use to identify the subscribed device)
  - Choose to enable the digital and/or analog GOOSE:

- MAC address (the destination address for the UPLC's GOOSE message)
- APPID
- VLAN Priority
- GSE Control appID

These will need to be correct for the UPLC™ to subscribe to other devices to properly detect and process the information.

Figure 8–6 shows the GOOSE definitions page.

The .cid file will need to be uploaded to the UPLC™. This is temporarily created manually. It must be named "api\_uplc.cid". AMETEK will assist any customer with their configuration.

The UPLC™ uses the "private subscription" section of the standard, since there are not standard object definitions at this time. A sample file is available from your local AMETEK sales representative.

What's available?

#### Settings:

- ChannelType
- RelayingFunction
- TransmitterFrequency
- ReceiverFrequency
- ONOFFBandwidth
- FSKTransmitterBandwidth
- FSKReceiverBandwidth
- FSKTransmitterShift
- FSKReceiverShift
- TransmitterHighPower
- TransmitterLowPower

#### GOOSE Outputs and Alarms:

The outputs are divided into "high speed" and "slow speed" GOOSE messaging. The outputs that are direct protective functions are interpreted and transmitted immediately (less than 1 ms) while those that are not direct protective functions are transmitted after a time period of approximately 5 ms to see if a high speed output change occurs prior to the time period. Should a high speed element

change, then the message is transmitted immediately. These are outputted via the same “GOOSE” message. The only difference is the processing time. The high speed GOOSE outputs are bolded in the “Output” list below. The other outputs (as listed in Alarms) are slow speed GOOSE elements.

**Alarms**

These are the data items available from the UPLC™ to indicate functionality/health of the device. These are non-protection based functions.

- GeneralFail
- ReflectedPowerAlarm
- TransmitterKeyedState
- ReceivedState
- PowerAmpOneAlarm
- PowerAmpTwoAlarm
- FSKLowLevel
- ONOFFCheckbackMajorAlarm

- ONOFFCheckbackMinorAlarm
- ONOFFCheckbackInRecovery
- ONOFFCheckbackAutoOff
- ONOFFCheckbackRecovered
- ONOFFCheckbackDelayedAlarm
- ONOFFCheckbackPassed
- ONOFFCheckbackOff
- ONOFFCheckbackInProgress
- ONOFFFadeAlarm
- PowerSupplyOneAlarm
- PowerSupplyTwoAlarm
- FSKFadeMarginAlarm
- FSKFadeAlarm
- FSKShiftLowFrequency
- FSKShiftHighFrequency
- RF Output

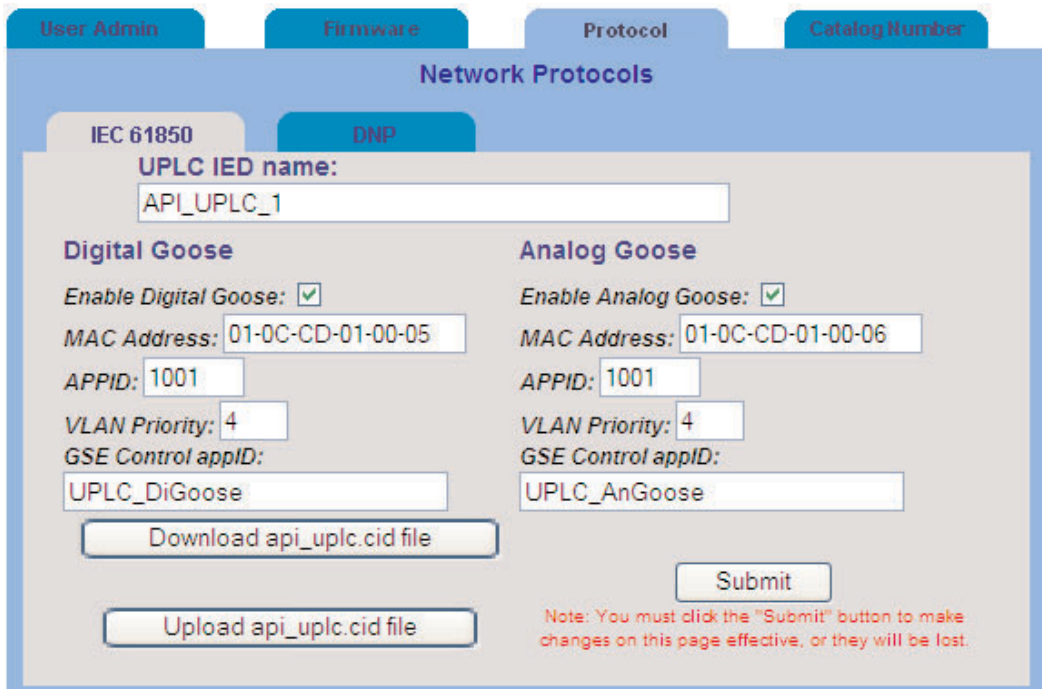

Figure 8–6. GOOSE Definitions Page.  
(Admin > Protocol > IEC 61850)

## Outputs

These are the protection based outputs and therefore the “high” speed GOOSE data items.

FSKTripOne  
 FSKGuardOne  
 FSKTripTwo  
 FSKGuardTwo  
 FSKGoodChannel  
 FSKNoise  
 FSKCheckBackTripOne  
 FSKCheckBackTripTwo  
 FSKTripPositive  
 FSKTripNegative  
 ONOFFBlockingOutput

## Control

These data items allow the user to program functions for testing in the UPLC.

ONOFFCheckbackInitiate  
 ONOFFLoopback  
 FSKTripTestInitiate  
 FSKTripTestDisable  
 FSKTripTestReset

## Subscribed data:

These are the data items that the UPLC™ will subscribe (listen) to. The data items must be identified in the CID file just as shown below. The remote device labeling can be anything the user desires. The position of the data item in the list is what determines the function, not the label.

ONOFFCarrierStart  
 ONOFFCarrierStop  
 ONOFFLowLevelKey  
 ONOFFCheckbackReset  
 ONOFFCheckbackInitiate  
 ONOFFLoopBack  
 FSK52BKey

FSKTripKey  
 FSKLRKey  
 FSKDTTKey  
 FSKAkey  
 FSKBKey  
 FSKPowerOff  
 FSKTripTestInitiate  
 FSKTripTestDisable  
 FSKTripTestReset

## Measured Values:

These are analog values continuously sent via the analog GOOSE. These values can be used for reporting functions as needed by the user.

TransmitPowerLevel  
 ReceiveLevel  
 Margin  
 ReflectedPower

## 8.5.2 Private GOOSE Subscription Details

This section outlines the method by which the UPLC™ subscribes to and assigns functions to IEC 61850 GOOSE messages. The method of defining the GOOSE message that the UPLC™ uses is the IEC 61850 Private Data type. This section also describes the functions that can be assigned to incoming data.

Please note that the definition of “GOOSE” message within this section follows the definition of GOOSE messaging in IEC 61850 part 8, and should not be confused with UCA GOOSE messages (known as GSSE in IEC61850). You are encouraged to obtain a copy of the standard.

It is assumed that you are somewhat familiar with GOOSE messaging and the IEC 61850 standards. It is also assumed that you are familiar with the idea of configuration files using the Substation Configuration Language (SCL), and the definitions of .ICD and .CID as device description files.



### 8.5.3 Overview

The UPLC™ is capable of using the Configured IED Description file as a means of defining the communications parameters and the data of GOOSE Messages that the user needs the UPLC™ to “listen” to and perform functions based upon the data received. This definition of the Goose message is accomplished by using an IEC private data block containing the information in a structured manner. The private data block is contained within the UPLC™’s .cid file, and can be edited to produce the desired data to function mapping.

When editing the .cid file, you should use a non-formatting editor such as Windows® Notepad, or if a formatting editor is used then be sure to save the file as a plain ASCII text file. The SCL interpreter is sensitive to embedded formatting characters, or ANSI escape sequences. If the .CID file contains these characters the file will not load.

Figure 8–7 shows an example of the UPLC™ <Private /> GOOSE subscription block.

The color coding is as follows:

Green – The <Private> </Private> block as described in the IEC61850 section “Private parts”

Blue – The UPLC™ private definition of a “GooseSubscription”.

Proper XML and IEC formatting require the use of a “Private namespace” denoted by the eapi: prefix, and an opening item paired with a closing item. i.e. <eapi:GooseSubscription>..... </eapi:GooseSubscription>. Note that all IEC definitions ARE case sensitive. The GooseSubscription contains the communication parameters, and the IEC data that uniquely identify the incoming GOOSE. Due to publication formatting, this line has been split into multiple lines, but in the actual .cid file, it is one long line.

Orange – order sensitive multiple definitions that correspond with the data order of the incoming GOOSE message.

These definitions allow the UPLC™ to call functions based upon the incoming data value. Note that the number of definitions MUST correspond to the number of data items contained in the received GOOSE message, EXACTLY. For example, if the GOOSE message contains 6 items, then there MUST be 6 definitions. This is true regardless if the data is to be used by the UPLC™ as an input to the function or if the UPLC™ is to ignore the data. The null function “UPLCNoFunction” is provided for

```

<Private type="AMETEK_GooseSubscription">
    <eapi:GooseSubscription iedName="SEL_421_1" IdInst="CFG" cbName="Conf" datSet="PLC"
    confRev="1" mAddr="01-0C-CD-01-00-02" maxTime="500" vlanPriority="4" appId="SEL_421_1"
    goCbRef="SEL_421_1CFG/LLN0$GO$PLC" datSetRef="SEL_421_1CFG/LLN0$PLC">
        <eapi:GooseRxEntry gooseData="FSKTripTestDisable" type="Bool" />
        <eapi:GooseRxEntry gooseData="ONOFFCarrierStart" type="Bool" />
        <eapi:GooseRxEntry gooseData="ONOFFCarrierStop" type="Bool" />
        <eapi:GooseRxEntry gooseData="ONOFFCheckbackReset" type="Bool" />
        <eapi:GooseRxEntry gooseData="UPLCNoFunction" type="Bool" />
        <eapi:GooseRxEntry gooseData="UPLCNoFunction" type="Bool" />
    </eapi:GooseSubscription>
</Private>
    
```

Figure 8–7. Example GOOSE Subscription Block.

the purpose of ignoring the value from the perspective of the UPLC™.

The GOOSE subscription private data MUST be defined within the <IED>...</IED> section of the .cid file.

Below are the detailed descriptions and definitions for each of the above sections.

## IEC Private Parts

The IEC allows for the use of extensions within the .CID file. These extensions are for manufacturers' use, and are not standardized as to the content. The unique identification of the private data objects is accomplished by using XML namespaces. A full description of this is beyond the scope of this manual. For further education you are referred to the XML standards available at [www.w3.org](http://www.w3.org) and the IEC 61850 standards.

## The UPLC GooseSubscription Definition

The UPLC™ GooseSubscription contains attributes that define the IEEE 802.1Q vlan information and the IEC 61850 information that uniquely identify the incoming GOOSE message. The need for the identification is to allow the UPLC™ to reject GOOSE messages at the various layers of the protocol.

From the example above:

```
<eapi:GooseSubscription iedName="SEL_421_1"
ldInst="CFG" cbName="Conf" datSet="PLC"
confRev="1" mAddr="01-0C-CD-01-00-02"
maxTime="500" vlanPriority="4"
a p p I d = " S E L _ 4 2 1 _ 1 "
goCbRef="SEL_421_1CFG/LLN0$GO$PLC"
datSetRef="SEL_421_1CFG/LLN0$PLC">
```

### GooseSubscription Attributes:

iedName

This is the name of the sending IED.

ldInst

The identifier of the <GSE/> protocol communication definition. Also contained in the data definition per data item within the <FCDA/> for each.

cbName

The control block name of the issuing GOOSE messages' control block.

datSet

The data set name of the data contained within the issuing GOOSE message.

confRev

The configuration revision contained within the control block of the issuing message.

mAddr

The GOOSE messages' destination address.

maxTime

Maximum time to live in milliseconds.

vlanPriority

The 802.1Q vlan priority level.

appId

The appId assigned to the GOOSE message by the <GSEControl /> block.

goCbRef

The IEC61850 address of the GOOSE control.

datSetRef

The IEC61850 address of the data set.

## The UPLC GooseRXEntry Definitions

When GOOSE messages are defined in an IED's .cid file they consist of three separate "parts". In the <Communication/> block there is the <GSE /> definition, which defines the destination address ("MAC address"), the APPID and the VLAN-PRIORITY. In the <IED> <AccessPoint> <Server><LDevice><LN0> block, there are two definitions that contribute to the GOOSE message:

The <DataSet> and the <GSEControl>.

The <GSEControl> creates an instance in the server that allows for control of the GOOSE messaging from the IEC 61850 client-server access.

The <DataSet> contains a list of data entries each known as <FCDA>. These entries form the content of the GOOSE message. The number of entries and the order of the data are defined by the IEC 61850 variables contained within the <FCDA>s.

You are encouraged to seek the relevant sections of the standards for further information regarding GOOSE message definitions.

For the purposes of this section, it is necessary to determine the number of entries in the GOOSE message subscription, what type they are, and the order the entries are in.

For each entry in the GOOSE message there MUST be a corresponding entry in the UPLC™ GooseSubscription block. Both the order and the number of entries must be exact.

Note: The UPLC™ at this time is only capable of receiving BOOLEAN entries from a GOOSE message.

As an example, suppose that IED “OaklandPark” is issuing a GOOSE message containing the following:

```
<Communication>
< SubNetwork name="W01" type="8-MMS">
  <ConnectedAP iedName="OaklandPark" apName="S1">
    <GSE IdInst="C1" cbName="TripControl" >
      <Address>
        <P type="MAC-Address">01-0C-CD-01-00-01</P>
        <P type="APPID">1001</P>
        <P type="VLAN-PRIORITY">4</P>
      </Address>
      <MaxTime unit="s" multiplier="m">500</MaxTime>
    </GSE>
  </ConnectedAP>
</SubNetwork>
<Communications>
```

(The above example is edited to show only the items that are needed to define the UPLC™ GOOSE subscription. In an actual .cid file, there will be more blocks between <ConnectedAP> and </ConnectedAP> defining the systems’ OSI addressing, and optionally other interfaces, such as serial, and possibly other GOOSE messages.)

Further, suppose that IED “OaklandPark” has the following located in the <IED> section:

(For clarity, there are line breaks between the <FCDA> entries. Normally this is not done within

the file. Also, the <FCDA> entries are contained in one line, however due to the limitations of the width of this section, the entry wraps around. The same wrap around occurs in the <GSEControl>)

```
<IED name="OaklandPark">
...(Services are defined here)
<AccessPoint name="S1">
  <Server>
    <LDevice desc="description" inst="C1">
      <LN0 desc="description" lnType="LN0" lnClass="LLN0" inst="">
        <DataSet name=" TripControlData" desc="Goose Trip Control
Data">
          <FCDA IdInst="C1" lnClass="LLN1" lnInst="1" doName="TripOne"
daName="stVal" fc="ST" />
          <FCDA IdInst="C1" lnClass=" LLN1" lnInst="1" doName="TripTwo"
daName="stVal" fc="ST" />
          <FCDA IdInst="C1" lnClass=" LLN1" lnInst="1" doName="52B"
daName="stVal" fc="ST" />
          <FCDA IdInst="C1" lnClass=" LLN1" lnInst="1"
doName="DisableTx" daName="stVal" fc="ST" />
          <FCDA IdInst="C1" lnClass=" LLN1" lnInst="1"
doName="TripTestStart" daName="stVal" fc="ST" />
        </DataSet>
        <GSEControl name=" TripControl" confRev="1"
appID="TripControlappID" datSet="TripControlData" desc="Station
Trip Control"/>
      </LLN0>
    </LDevice>
  </Server>
</AccessPoint>
</IED>
```

Using the data above, the UPLC™ Goose subscription can be constructed:

```
<Private type="Ametek GooseSubscription">
  <eapi:GooseSubscription iedName=" OaklandPark " IdInst="CFG"
cbName="TripControl " datSet=" TripControlData " confRev ="1"
mAddr="01-0C-CD-01-00-01" maxTime="500" vlanPriority="4"
appID=" TripControlappID "
goC b R e f = " O a k l a n d P a r k C 1 / L L N 0 $ G O $ T r i p C o n t r o l "
datSetRef="OaklandParkC1/LLN0$TripControlData">
  <eapi:GooseRxEntry gooseData="FSKTripKey" type="Bool"/>
  <eapi:GooseRxEntry gooseData="FSKTripKey" type="Bool"/>
  <eapi:GooseRxEntry gooseData="FSK52BKey" type="Bool"/>
  ....<eapi:GooseRxEntry          gooseData="FSKTripTestInitiate"
type="Bool"/>
  <eapi:GooseRxEntry gooseData="FSKPowerOff" type="Bool"/>
</eapi:GooseSubscription/>
```

</Private>

(The `gooseData="xxxxx"` map the incoming GOOSE bits to UPLC™ input functions. These keywords and definitions are in the next section.)

Note that there are 5 GOOSE entries in the example. The number of GOOSE entries MUST agree with the GOOSE message and the GOOSE subscription, otherwise the GOOSE message will be rejected by the UPLC™.

### UPLC GOOSE subscription input functions

The UPLC™ provides the following input functions for mapping to incoming GOOSE data. Note that these functions are positive logic (1 = TRUE).

`ONOFFCarrierStart`

Turn on the transmitter in AM mode only.

`ONOFFCarrierStop`

Turn off the transmitter in AM mode only. The priority of these items is set in the UPLC™ logic settings.

`ONOFFLowLevelKey`

Turn on transmitter at the low power setting.

`ONOFFCheckbackReset`

Clear all checkback alarms.

`ONOFFCheckbackInitiate`

Start a checkback test. Progress and results can be monitored via the UPLC™ output GOOSE.

`ONOFFLoopBack`

Start a loopback test.

`FSK52BKey`

Boost the transmitter to high power in FSK mode.

`FSKTripKey`

Key the transmitter to Trip in FSK.

`FSKLRKey`

Key the transmitter to LR Trip in FSK 3F and 4F function only.

`FSKDTTKey`

Key the transmitter to DTT Trip in FSK 3F and 4F function only.

`FSKAKey`

Key the transmitter to A in FSK 4F mode only.

`FSKBKey`

Key the transmitter to B in FSK 4F mode only.

`FSKPowerOff`

Turn off the transmitter.

`FSKTripTestInitiate`

Start a trip test.

`FSKTripTestDisable`

Disable trip tests system wide.

`FSKTripTestReset`

Reset trip test alarms.

`UPLCNoFunction`

Do nothing.

Notes:

1. The ONOFF prefix means the function will operate in ON-OFF mode only. FSK prefix means that the function will operate in FSK mode only.
2. Some functions are used in specific relaying functions only. For example, `FSKAKey` and `FSKBKey` will operate in FSK 4 Frequency mode only.
3. These functions may be overridden by local settings. For example, if the UPLC™ logic setting checkback is disabled, then the `ONOFFCheckbackInitiate` will have no effect. All inputs and logic settings must allow for the function to operate.
4. `ONOFFCheckbackInitiate`, `ONOFFLoopback`, `FSKTripTestInitiate` all operate on a transition from a logic FALSE (Input value '0') to a logic TRUE (Input value '1'). The tests will operate then finish. For the test to be initiated again, the input MUST return to FALSE, then TRUE. If a test is in progress and the input changes state from TRUE, to FALSE, then TRUE again, there will be no effect. i.e. the test inputs are not "queued" in the time dimension.
5. The function `UPLCNoFunction` is provided as a place holder so that the UPLC can ignore bits in

the incoming GOOSE message at the user's discretion.

- All of these inputs are type="Bool" which is short for BOOLEAN as defined by IEC 61850.

### Downloading, modifying, and uploading the api\_uplc.cid data file

(It is assumed that you are familiar with the UPLC™ web page interface. If not, please refer to the UPLC™ installation manual for details.)

The UPLC™, when enabled for IEC 61850 protocol, has the ability to generate an api\_uplc.cid file on the tab located under Admin->Protocol>IEC 61850 (See Figure 8–6).

The settings on this page (Fig. 8–8) allow you to change the parameters of the UPLC™ 61850 operation regarding the GOOSE messages produced by the UPLC™. To obtain a copy of the UPLC™ api\_uplc.cid file, click the button "Download UPLC .CID file". The browser interface will

prompt you to save the api\_uplc.cid file to your local hard drive.

You then may edit the api\_uplc.cid file to construct a GOOSE Subscription.

The default api\_uplc.cid file contains a sample GOOSE Subscription block that may be edited. Be sure to use a non-formatting text editor such as Windows® Notepad, or a programming editor.

Figure 8–8 shows the api\_uplc.cid file with the yellow line indicating the start of the GOOSE Subscription block. Due to rapid development, the actual api\_uplc.cid file may be slightly different than shown. Also note that in this editor lines do not wrap, so the attributes of the GOOSE subscription are not all shown.

You can now make changes to the GOOSE subscription data.

```

<?xml version="1.0" encoding="UTF-8" standalone="no" ?>
<Address>
  <CP type="MAC-Address">01-0C-CD-01-00-05</CP>
  <CP type="RPPID">1001</CP>
  <CP type="ULAN-PRIORITY">4</CP>
</Address>
</GSE>
<GSE idInst="CI" chName="DSetAnalog" eapi:GooseEnable="1">
  <Address>
    <CP type="MAC-Address">01-0C-CD-01-00-06</CP>
    <CP type="RPPID">1001</CP>
    <CP type="ULAN-PRIORITY">4</CP>
  </Address>
</GSE>
</ConnectADP>
</SubNetwork>
</Communication>
<IED name="API_UPLC_1">
  <Private type="MIEP" GooseSubscription>
    <api:GooseSubscription idName="S1_421_1" idInst="CFG" chName="Conf" datSet="PLC" confRev="1" mAddr="01-0C-CD-01-00-02" maxLine="500">
      <api:GooseREntry gooseData="PSKTripsDisable" type="Bool" />
      <api:GooseREntry gooseData="ONOFFCarrierStart" type="Bool" />
      <api:GooseREntry gooseData="ONOFFCarrierStop" type="Bool" />
      <api:GooseREntry gooseData="ONOFFCheckbackReset" type="Bool" />
      <api:GooseREntry gooseData="UPLCNoFunction" type="Bool" />
      <api:GooseREntry gooseData="UPLCNoFunction" type="Bool" />
    </api:GooseSubscription>
  </Private>
  <Services>
    <DynAssociation/>
    <GetDirectory/>
    <GetDataObjectDefinition/>
    <GetDataSetValue/>
    <DataSetDirectory/>
    <ReadWrite/>
    <FileHandling/>
    <ConfDataSet max="4" maxAttributes="50"/>
    <ConfReportControl max="12"/>
    <ReportSettings bufTime="Dyn" chName="Conf" rptID="Dym" datSet="Conf" intgPd="Dym" optFields="Conf"/>
    <ConfLogControl max="1"/>
    <ConfLog FixInst="true"/>
    <GetCBValues/>
    <GOOSE max="2"/>
    <DataSetInst appID="Conf" chName="Conf" datSet="Conf"/>
  </Services>
  <AccessPoint name="S1">
    <Server>
      <Authentication/>
      <LDDevice desc="description" inst="CI">
        <LN0 desc="description" inst="LN0" inType="LN0" inClass="LN0" inst="">
          <DataSet name="DSetGoose" desc="Goose Output Variables">
            <PCDR idInst="CI" inClass="ZPLC" inInst="1" daName="PSKTripOne" daName="stVal" fc="ST"/>
            <PCDR idInst="CI" inClass="ZPLC" inInst="1" daName="PSKGuardOne" daName="stVal" fc="ST"/>
            <PCDR idInst="CI" inClass="ZPLC" inInst="1" daName="PSKTripTwo" daName="stVal" fc="ST"/>
            <PCDR idInst="CI" inClass="ZPLC" inInst="1" daName="PSKGuardTwo" daName="stVal" fc="ST"/>
          </DataSet>
        </LN0>
      </LDDevice>
    </Server>
  </AccessPoint>
</IED>

```

Figure 8–8.UPLC™ .cid File.



# Index

<b>-A-</b>		<b>-G-</b>	
Address .....	7-4	Gain Measurements .....	6-3
Alarm .....		GOOSE Message/Subscription .....	8-8
Delayed .....	7-4	Guard Before Trip .....	2-11, 2-12, 7-13
Minor .....	7-4	Guard Frequency .....	2-5
Major .....	7-4	Guard Hold Timer .....	2-12
Alarms .....	7-10	<b>-H-</b>	
Amplifier .....	2-5	Hybrid .....	3-18
Analog Inputs .....	8-7	<b>-I-</b>	
Auto Recovery .....	7-7	I/O Module Jumpers .....	2-13
Automatic Checkback Tests .....	7-5	IEC 61850 .....	8-8
Automatic Checkback .....	7-1	Input/Output Configuration .....	5-4
<b>-B-</b>		Inspection .....	6-2
Backplane (rear panel) .....	2-1	Interval type .....	7-5
Battery .....	2-19	<b>-J-</b>	
Battery, NOVRAM .....	6-4	Jumpers .....	2-13
Binary Inputs .....	8-3	<b>-L-</b>	
<b>-C-</b>		Last Remote .....	7-4
Center Frequency .....	2-10, 3-16	Logic Settings .....	5-3
Channel Clamp .....	3-8	Loopback .....	7-2, 7-6
Channel Considerations .....	3-5, 3-15	Low Power .....	7-6
Chassis .....	iv, 1-1, 2-1, 2-3, 2-4, 7-2	<b>-M-</b>	
Checkback .....	1-1, 2-6, 2-11, 3-25, 7-1-7-18	Maintenance .....	6-2
Checks periodic .....	6-1	Maximum Checkback Configuration .....	7-5
Clock .....	7-7	Modules .....	2-1
Comparator .....	2-18, 3-36	<b>-N-</b>	
Configuration File .....	5-1	Network Troubleshooting .....	7-10
Configuration Report .....	5-8	Nomenclature .....	2-1
Connections .....	2-17, 2-17, 3-2, 3-14, 3-19, 3-20	Nominal Receiver Bandwidths .....	2-18
<b>-D-</b>		<b>-O-</b>	
Directional Comparison .....	2-6-2-18	On/Off Automatic Checkback .....	7-1
Unblocking .....	3-1-3-33	Optional Tests .....	7-1
Direct Transfer Trip .....	1-1, 2-9-2-12, 3-1-3-20	Ordering .....	1-1
DTT Channel Considerations .....	3-15	<b>-P-</b>	
DNP 3 .....	8-1	PC Interface .....	7-1
Dual Phase Comparison Unblocking .....	3-1, 3-7	Periodic Checks .....	6-1
<b>-E-</b>		Phase Comparison .....	3-25
Encoded Carrier Tests .....	7-9	Power Requirements .....	2-19
Environmental Specifications .....	2-19	Power Supply .....	2-14
<b>-F-</b>		Precautions .....	6-1
Fallback Timed Comm .....	7-1, 7-4, 7-8, 7-9	Primary Communications Options .....	7-9
Four-Frequency Application .....	3-17	Protective Relay Applications .....	
Frequency Spacing .....	2-18	FSK .....	3-1
Front Panel .....	2-1, 2-2, 2-5, 2-6	ON/OFF .....	3-25
Functional Description .....	2-5	Protocols .....	1-2, 8-1

## Index (cont'd)

### -R-

Rear Panel (backplane) .....	2-13
Remote Communications .....	7-2
Retries .....	7-5

### -S-

Servicing the unit .....	6-3
Settings .....	7-4
Shunt Reactor Protection .....	3-15
Specifications .....	2-18

### -T-

Three-Frequency Applications .....	3-17
Transfer-Trip Systems .....	3-17
Transformer Protection .....	3-13
Trip Test .....	7-14
Troubleshooting .....	7-9
Two-Frequency Applications .....	3-16



**Pulsar**