

CONNECTIONS FOR STANDARD MODEL

WIRING FOR ISOLATED FIELD CONTACT WIRING

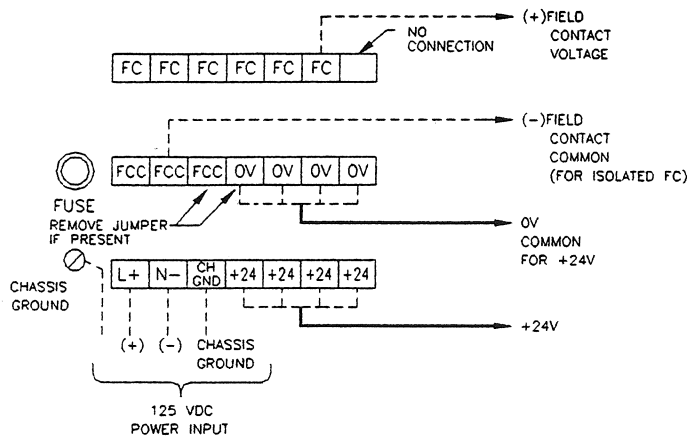

WIRING FOR NON-ISOLATED FIELD CONTACT WIRING

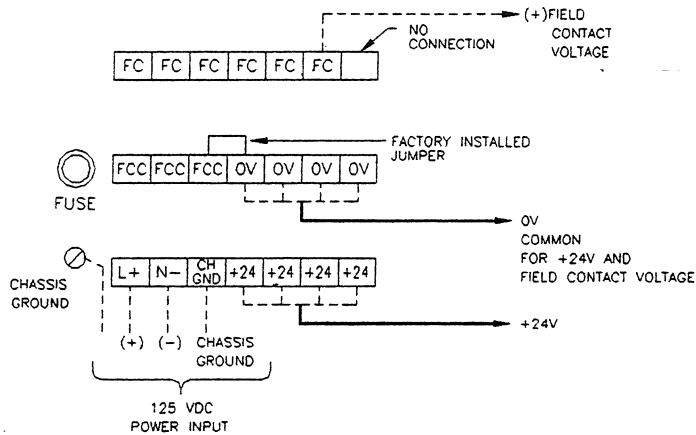

CONNECTIONS FOR MODELS WITH POWER TRANSFER OPTION (1PT) USING 90P18 SUPPLY AS BACKUP
WIRING FOR ISOLATED FIELD CONTACT WIRING

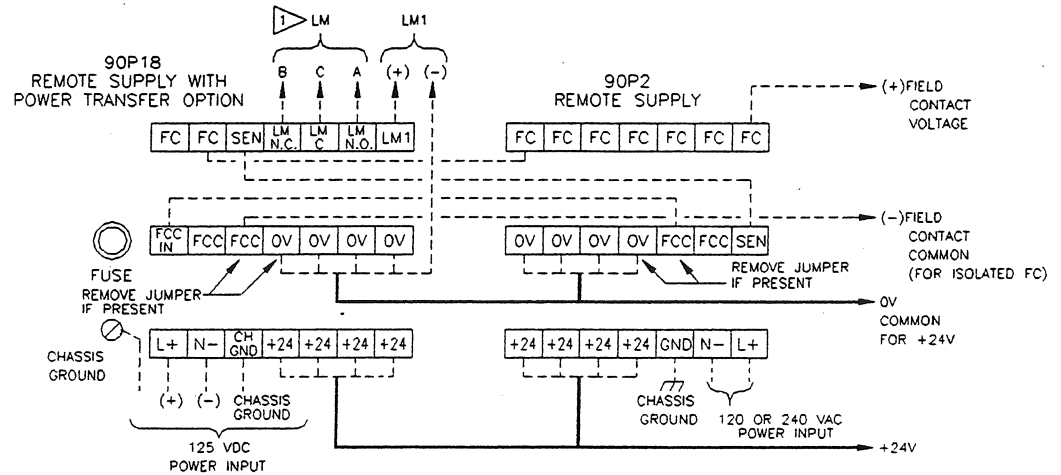

WIRING FOR NON-ISOLATED FIELD CONTACT WIRING

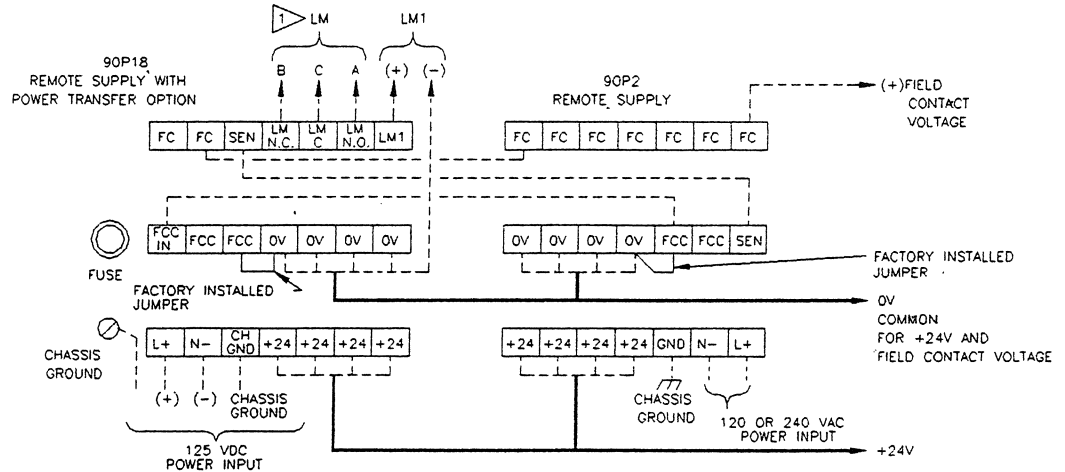

FOR F.M. APPLICATION CLASS 1, DIVISION 2, GROUPS A, B, C, AND D. WHEN LM IS REQUIRED ON 1PT OPTION

CONTACTS RATINGS RESISTIVE LOAD ONLY			
VOLTAGE	CURRENT	VOLTAGE	CURRENT
250 VDC MAX	10.8 mA	12 VDC	4.5 A
125 VDC	17.1 mA	6 VDC	4.5 A
48 VDC	54 mA	240 VAC MAX	9.9 mA
24 VDC	225 mA	120 VAC	13.5 mA

DASHED LINES INDICATE CUSTOMER FIELD WIRING

POWER INPUT WIRING

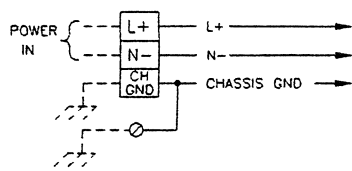

USED ON:
C.S.A. CERTIFIED EQUIPMENT,
U.L. LISTED EQUIPMENT &
F.M. APPROVED EQUIPMENT

CAUTION: REFER TO INSTRUCTION MANUAL NO. 900383 PRIOR TO INSTALLATION FOR ADDITIONAL OPERATING INFORMATION AND RATINGS.

REV	ECN NO.	BY	APPD	DATE	MATERIAL:
01	7058-02	SM	GG	09/17/91	FINISH:
02	10892-01	SK	JT	03/26/92	USED ON/REF. DWG
03	11098	SM	CNL	08/12/92	90P*
04	7058-06	SK	AHD	01/22/93	90100-P18-1
05	11494-02	AD	JT	10/17/94	
06	11872	SK	MAL	06/15/01	

TOL. UNLESS SPECIFIED
INCHES
.X = .015
.XX = .010
.XXX = .005
MILLIMETERS
X.O = 1.0
O.X = 0.4
O.XX = 0.1
ANGLES ±0°30'
SCALE INCH
NONE (MM)

DWG. BY S.M.
APPO/DATE GG 06/10/91
THIRD ANGLE PROJECTION

AMETEK

PANALARM 1725 WESTERN DRIVE, WEST CHICAGO, ILL. 60185, U.S.A.
PHONE: 1-630-231-5900 FAX: 1-630-231-4502

WIRING DIAGRAM, MODEL 90P18*,
450 WATT, REMOTE POWER SUPPLY

SHEET 1 OF 1 DWG. NO. 90450-P18-1 C